



Using VDSL2 over copper in the vertical string

E. Heine,^a J. Hogenbirk,^a P.P.M. Jansweijer,^{a*} H.Z. Peek,^a

^a*Nikhef, Kruislaan 409, 1098 SJ Amsterdam, Netherlands*

Elsevier use only: Received date here; revised date here; accepted date here

Abstract

The described system can be used in a sub-marine Very Large Volume neutrino Telescope where data is transported from Optical Modules (OM), arranged in vertical strings, into the on-shore data acquisition system using copper twisted pairs for the short runs and fiber optics for the long distance connection. All data communication, timing and timing calibration between the Shore Station and the OMs as well as the distribution of power, is done via a single Master Module (MM) in the vertical string. VDSL2 provides more than 100 Mbps bandwidth via a single copper twisted pair to transport all the data from an OM to the MM. The same twisted pair is also used to transport power and timing to the OM. A single channel of the long distance fiber optical Dense Wavelength Division Multiplexing system provides the data communication from a MM to the Shore Station. Reliability is a design issue; a large part of the system uses common infrastructure. Each vertical string has two separate paths to the Shore Station via separate Junction Boxes. Destructive single point failures in the common infrastructure divide the system in two parts, but each part is independently fully functional.

© 2008 Elsevier Science. All rights reserved

PACS: Enter PACS number(s) here

"Keywords: Copper; VDSL; VDSL2; Twisted Pair; Vertical String; Store and Forward; Timing Calibration; Neutrino Telescope"

1. Introduction

Very Large Volume neutrino Telescopes will be used to study astrophysical sources. Such telescope

consists of a large sub-marine three-dimensional array of Optical Modules (OM) which contain light-sensitive Photo Multiplier Tubes (PMTs). OMs are arranged in vertical strings, each served by a Master Module (MM). The main purpose of the Data Acquisition system is to convert the analogue signals

* Corresponding author. Tel.: +0031-20-5922039; e-mail: peterj@nikhef.nl.

from the PMTs into a format suitable for the physics analysis.

One of the major demands for the Data Acquisition system is the time measurement accuracy. This requires a high timing accuracy for the communication between Shore Station and neutrino telescope. The described system uses local time stamping in the OM and a relatively low bandwidth store and forward transmission system via a single copper twisted pair between each OM and MM. Such a system needs distributed clocks which are synchronous.

2. Bandwidth estimation

The bandwidth needed for data transport is proportional to the photon flux per photo cathode area. Experience with ANTARES gives an average bandwidth of 20 Mbps per OM [1]. For a vertical string, equipped with 24 OMs, this adds up to 480 Mbps.

This data rate increases due to multiplication by a safety factor (overhead and margin). This safety factor for a given telescope architecture should be studied. With a safety factor of 5 (as for example used at ATLAS [2]), the bandwidth per vertical string stays below 3.1625 Gbps which is widely used in current Ethernet standards [3].

To accommodate the bandwidth, an optical Dense Wavelength Division Multiplexing (DWDM) approach is needed for the long distance connection (one λ per vertical string) between the Shore Station and the telescope-site. However, in the vertical strings, distances are much smaller and the bandwidth per OM is lower (~100 Mbps, including safety factor). For this bandwidth a cost effective electrical approach can be used.

3. Data communication over copper

In the modern world, almost all houses are connected via a copper wire to a telecommunication network. Over the past 20 years this copper connection is also used for data transport. High speed Internet access and High Definition Television (HDTV) are becoming standard; the bandwidth

demand is ever growing. Although fiber to the home (FTTH) is the ultimate answer, it is often not an economically viable solution for overbuilding existing copper networks [4]. To accommodate the bandwidth demand over copper subscriber loops, there has been an evolution from ADSL, ADSL2, ADSL2+ to VDSL, followed by VDSL2 (ITU G.993.2 standard [5]). VDSL2 provides enough bandwidth for “triple play” (Voice, Video and Data). Telecommunication industry is a very cost sensitive mass market; the cost of VDSL2 chipsets is low.

The VDSL2 Broadband Network frequency band spans from 25 KHz to 30 MHz. This bandwidth can accommodate up to 200 Mbps (upstream + downstream) which is transparent to the user. The same copper pair also carries DC power and a dedicated timing channel (figure 1).

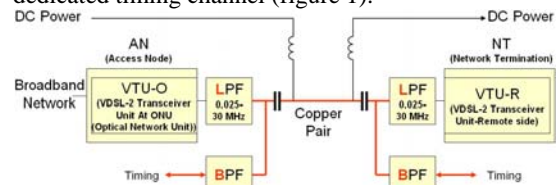

figure 1: Application Model for the connection between an OM and a MM (based on the ITU G.993.2 standard, figure 5-7)

4. Timing

4.1. General

VDSL2 has no fixed latency, thus a store and forward mechanism must be used. Such a system must create a timestamp at the origin of an event, i.e. at the output of the PMT in the OM. This means that each OM needs an exact time reference that is phase locked onto the system reference clock at the Shore Station. All clocks in the system are locked so this ensures that all clocks are isochronous but due to interconnect distances the local time in each OM is not synchronous. The timing offset can be measured from the Shore Station, by sending a timing calibration signal forth and back again. The actual path that must be calibrated consists of a long distance optical path (Shore Station to vertical string) and a short distance electrical path (within the

vertical string). The timing calibration signal is part of a packet which can also contain some additional data.

4.2. Timing calibration over an optical connection

The industry widely adopted 8B/10B coding [6] as a standard for serial data transport. Apart from data transport, such a system could also be used for timing calibration.

The recovered bit clock at the receiver is locked to the transmitter and used as the local clock. A special character marks a timing calibration signal.

The calibrate signal sent from node “A” that is received in node “B” over the forward path, needs to be sent back immediately to node “A” (see figure 2). Normally there is no direct link between the receiver (RX) and the transmitter (TX) in node “B”. Data is usually received in a buffer, than interpreted by some intelligent device and eventually a reply is sent back to the transmitter via some buffering.

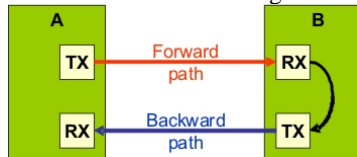

figure 2: Timing Calibration forward and backward path

Timing calibration however, needs a fixed latency data path in the receiving node “B” from receiver (RX) to Transmitter (TX). A special data packet is used to put node “B” in a state where it forwards the calibration signal transparently from receiver to transmitter without going through any buffers.

4.3. Timing calibration over a copper connection

The VDSL2 band plan stretches up to 30 MHz so a separate timing calibration system can use frequencies above. A timing calibration signal is modulated onto a carrier f_1 and transferred via the forward path (see figure 2). The received calibration signal from node “A” needs to be sent back immediately, using a carrier frequency f_2 via the backward path.

The preferred modulation scheme is Binary Phase Shift Keying (BPSK). This type of modulation is

easily made by using Direct Digital Synthesis (DDS) techniques [7, 8].

figure 3 explains how a node can be locked onto the transmitter clock and how a timing calibration signal can be transferred from a transmitter to a receiving node.

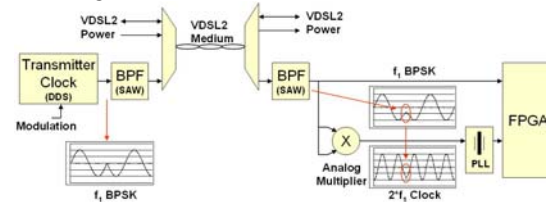

figure 3: Schematic overview of the timing calibration principle

A calibration signal is sent at an exact known phase of carrier f_1 . The BPSK signal is coupled into and out of the VDSL2 medium via band pass filters. Suitable filters are Surface Acoustic Wave (SAW) filters that have excellent band pass characteristic and a very low group delay distortion.

The carrier is regenerated when the analogue representation of the BPSK signal is multiplied by itself, resulting in the double frequency without modulation. Due to the limited bandwidth of the SAW filters there will be some distortions on the recovered carrier. The timing jitter is removed by feeding the recovered carrier through a Phase Locked Loop (PLL).

The carrier frequencies (f_1 , f_2) should be chosen such that:

1. They are > 30 MHz (above the VDSL2 band)
2. f_1 and f_2 have an “n/m” relationship
3. Reference period divided by the time of “n” cycles f_1 and “m” cycles f_2 , is an integer value

This ensures that f_1 and f_2 have a fixed phase relationship (e.g. have their zero crossing at the same time) on each reference period. The reference periods are locked to the one second timing reference of the Global Positioning System (GPS).

The GPS second tick is sent as a system “heartbeat” (see figure 4). This heartbeat is aligned with the start of a reference period and is an exact timing moment in a “heartbeat packet”.

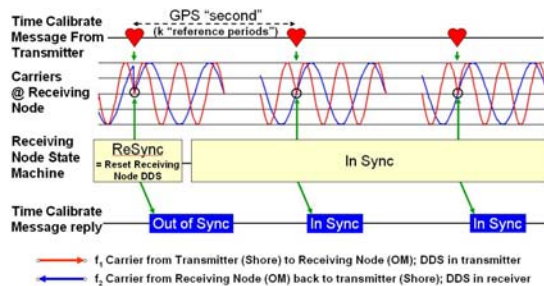

figure 4: Time calibration mechanism

With each heartbeat, the receiving node checks whether its f_2 carrier generator is “in sync” with the received f_1 carrier. Note that f_2 is generated with a DDS that is locked onto f_1 . If f_2 is out of phase then an “Out of Sync” message will be replied to the transmitter. When this happens repeatedly then the f_2 generator needs to be resynchronized such that it will be in phase with f_1 .

Since f_2 is locked to f_1 , at the next heartbeat the receiver will find itself in synchronization and the reply will be an “In Sync” message. In this way the receiving node is able to keep track of the exact time while the transmitter can measure the exact propagation delay and knows whether the receiving node is in sync.

5. Data acquisition system

All communication between the Shore Station and the OMs as well as the distribution of power, is done via MMs. The VDSL2 standard defines the names “Central Office (CO)” and “Customer Premises Equipment (CPE)” as the end-points of a connection. The MM contains CO chips that, on one side, connect to CPE chips in each OM and on the other side connect to an Ethernet switch. The wideband port of this switch is connected via a DWDM system to the Shore Station. figure 5 shows an expandable setup, where the centre of the figure shows a Branch Cable drawn in more detail. The Branch Cables are fed with communications and power from both sides (Junction Box “A” and “B”) and are connected to the MMs via two wideband ports (“a” and “b”). This architecture avoids single point failures by providing redundancy.

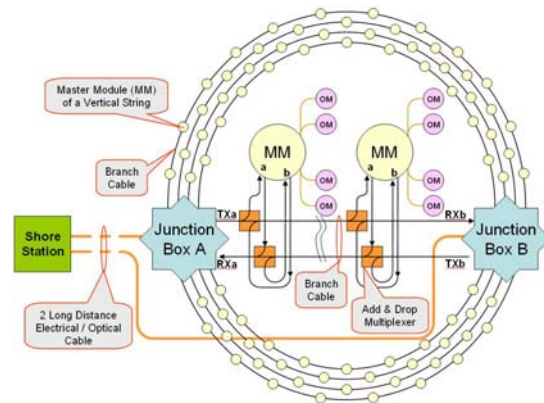

figure 5: Schematic overview of the telescope architecture where one DWDM Branch Cable is drawn in more detail (centre)

Acknowledgment

This work is part of the research program of the 'Stichting voor Fundamenteel Onderzoek der Materie (FOM)', which is financially supported by the 'Nederlandse Organisatie voor Wetenschappelijk Onderzoek (NWO)'.

The authors like to thank the company Infineon for providing VDSL2 support.

References

- [1] J.A. Aguilar et al. First results of the Instrumentation Line for the deep-sea ANTARES neutrino telescope, <http://lanl.arxiv.org/pdf/astro-ph/0606229v1>
- [2] ATLAS Collaboration, Muon Spectrometer Technical Design Report, CERN/LHCC/97-22 (1997).
- [3] IEEE Std 802.3ak-2004, “Physical Layer and Management Parameters for 10 Gb/s Operation, Type 10GBASE-CX4”
- [4] Per-Erik Eriksson and Björn Odenhammar. VDSL2: Next important broadband technology. Ericsson: http://www.ericsson.com/ericsson/corpinfo/publications/reviiew/2006_01/files/vdsl2.pdf
- [5] ITU-T G.993.2 “Very high speed digital subscriber line transceivers 2 (VDSL2) <http://www.itu.int/rec/T-REC-G.993.2/en>
- [6] A.X. Widmer, P.A. Franaszek. A DC-Balanced, Partitioned-Block, 8B/10B Transmission Code. IBM J. Res. Develop, Vol. 27, No 5, September 1983.
- [7] <http://www.analog.com/dds>
- [8] http://www.xilinx.com/products/ipcenter/DDS_Compiler.htm