



Time calibration of the NEutrino Mediterranean Observatory (NEMO)

Marco Circella,^{a,*} for the NEMO Collaboration

^a*Istituto Nazionale di Fisica Nucleare (INFN) – Sezione di Bari, via Amendola 173, I-70126 Bari, Italy*

Elsevier use only: Received date here; revised date here; accepted date here

Abstract

Large volume Cherenkov detectors are under construction or have been proposed for detection of astrophysical neutrinos under water or ice. In all such cases, the neutrinos are inferred from the detection of the Cherenkov light emitted by the charged leptons created in neutrino interactions inside or around the apparatus. The event reconstruction is thus based on charge and time measurements performed by a system of widely-spaced optical sensors. The time calibration is a very delicate operation for such experiments, as it may directly affect the reconstruction efficiency and pointing capabilities of the apparatus. In this paper, we illustrate the systems under study for the km³-scale project NEMO (NEutrino Mediterranean Observatory), focusing on the implementations for the NEMO Phase 1 and Phase 2 prototyping campaigns.

© 2008 Elsevier Science. All rights reserved

PACS: 95.55.Vj, 95.85.Ry

Keywords: neutrino telescope; time calibration; optical pulser; optical fibre

1. Introduction

Very large volume Cherenkov detectors represent nowadays the most common approach to neutrino astrophysics. The capabilities of these experiments are strictly dependent on how well time measurements are performed by the single sensors. In fact, the reconstruction of the physical events, which

have to be extracted from a large environmental background in the case of an undersea apparatus, is based on the possibility to properly align in time the measurements performed by a large number of widely spaced sensors. In all cases in which the signals are digitized and time-stamped offshore, two different tasks are required in order to be able to perform correct time measurements: synchronization of the electronics, i.e. the delivery of common clock signals to the whole apparatus, and timing calibration

* Tel.: +39-080-5442354; fax: +39-080-5442470; e-mail: marco.circella@ba.infn.it .

of the sensors, i.e. the measurement of how the local time measurements performed by the individual sensors compare to the time measured onshore. For such time calibration an embedded system is required in order to track the possible drifts of the time offsets during the operations of the apparatus underwater

In this paper we illustrate the time calibration approach under study for the NEMO (NEutrino Mediterranean Observatory) Project, focusing in particular on the implementation and performance of the systems tailored to the needs of the NEMO Phase 1 and Phase 2 prototyping campaigns.

2. The NEMO Project

The NEMO Collaboration has been established in 1998 with the aim to carry out the necessary R&D towards an underwater neutrino detector with a sensitive volume of the order of the km^3 .

The NEMO Collaboration has identified a suitable site for installation of such apparatus at a depth of 3500 m, about 80 km off the coast of Capo Passero, at the southernmost tip of Sicily, Italy.

The proposed layout of the telescope consists of 81 semi-rigid vertical structures, called *towers*, placed on a square grid with a pitch of 140 m in either direction. More details on the apparatus design and on the activities of the collaboration are reported in dedicated presentations at this conference [1, and references therein] and elsewhere [2].

3. The NEMO Phase 1 and Phase 2 campaigns

As intermediate steps toward the design of a full-scale km^3 apparatus, the NEMO Collaboration has launched the Phase 1 and Phase 2 prototyping campaigns, the former aimed at the implementation and operation of a reduced-size prototype of the apparatus at an underwater test site, and the latter aimed at building the infrastructure and operating a full-size tower at the 3500 m depth site proposed for the installation of a km^3 apparatus.

The test site chosen for the Phase 1 program is located at 2000 m depth about 20 km off the coast of Catania, in Sicily, Italy. This site is connected to a

control station located in the port of Catania by means of a long-distance electro-optical cable, one branch of which serves a second underwater test site devoted to geoseismic observations.

The Phase 1 apparatus consists of an underwater junction box and a reduced-size tower of the apparatus. These objects were installed in late 2006 and operated for various months during 2007.

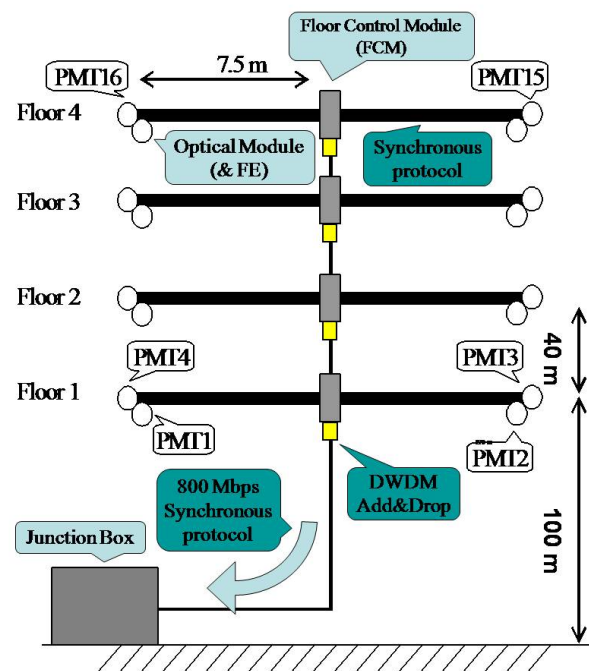

Figure 1: Layout of the prototype tower of NEMO Phase 1.

The schematic layout of the Phase 1 tower is shown in Figure 1. As the figure shows, this tower is composed of 4 floors, spaced by 40 m, with the bottom floor at 100 m above the sea bed. Each floor consists of a bar of 15 m length, equipped with four optical modules, each containing a photomultiplier tube (PMT) and its associated electronics. The optical modules are located at the two edges of each bar, in such a way that two of them are oriented downward, the other two horizontally.

The tower is designed so as to be integrated in a compact way. Once it is deployed on the bottom of the sea, it is possible, by activating a release system, to let it unfold to get its vertical position under the

pull of a top buoy. A system of ropes keeps consecutive floors perpendicular to each other.

The data acquisition of the optical modules of each floor is controlled by the Floor Control Module (FCM), which also controls the local instrumentation and all communications with the shore station.

The communications between each FCM and the shore are based on a synchronous communication protocol at a data rate of 800 Mbps. This choice guarantees enough bandwidth to transport to shore all the data collected, without any offshore filtering. A Dense Wavelength Division Multiplexing (DWDM) technique is used in order to sustain such high data rates on a limited number of optical fibres: standard wavelengths at 50 GHz spacing are used to communicate to and to receive data from each floor. The system is based on simple Add&Drop devices so that no active components are needed in the whole path between each FCM and its onshore counterpart.

Symmetric systems are implemented offshore and onshore. This gives the possibility to implement simple elaboration schemes onshore for detection of local signal coincidences. At the same time, it is possible to address individual communications to the different floors of the towers from the shore station.

The front-end electronics (FE) is located inside the optical modules. The main features of the FE can be summarized as follows:

- the signals are compressed before sampling with a quasi-logarithmic law;
- the analogue signals are then sampled and digitized at the frequency of 200 MHz, by means of two staggered fast-ADCs operated at 100 MHz.

The data are recorded when a threshold value, remotely set from onshore, is reached. When this condition occurs, the readout of a 16-bit counter, which is incremented at 100 MHz, is also recorded to provide information on the pulse detection time. In this way, it is possible to determine the time of the individual samples with a resolution of 5 ns, while sub-nanosecond resolution is achieved by reconstructing the full waveform of the signals starting from the values sampled at 200 MHz. Periodic counter-reset commands are broadcasted from shore to the whole apparatus.

The tower which is under construction for the NEMO Phase 2 program resembles very closely that of Phase 1, but extended to 16 detection floors. The

distance between consecutive floors is unchanged, so the total height of the tower is of about 700 m. Based on the experience of Phase 1, a few modifications have been made to the mechanical structure in order to simplify the integration operation of the tower and reduce the production costs. In particular the cabling system was revised, and the optical fibres dedicated to the calibration system in Phase 1 were replaced with twisted pairs. The data acquisition and transmission system of Phase 2 is a revised version of the Phase 1 implementation described above, although some innovative solutions are being also pursued and will equip a part of the tower.

4. The NEMO time calibration system

As explained in the previous section, the time measurements are performed by the optical modules by referring to counters which are incremented at a fixed frequency and are periodically reset upon execution of a reset-command sent from the shore.

The task of the time calibration system is therefore to measure the offsets with which these time counters are reset, i.e. the time delays for the reset commands to be reached and executed by the individual sensors. This operation is performed by sending calibration signals at known times to each optical modules and by comparing the known values of time with the measurements performed. In this way, the time response of the photomultipliers is also taken into account correctly.

Our attempt was to implement a system which could work for the NEMO towers but could be also scaled to even larger detectors. For this reason, we decided to use a number of fast (and cheap) optical pulsers, based on single LEDs, and a network of underwater connections for distributing the calibration pulses to the optical modules. In NEMO Phase 1 it was possible to use optical fibres for connecting each optical pulser to a group of optical modules, as illustrated in Figure 2.

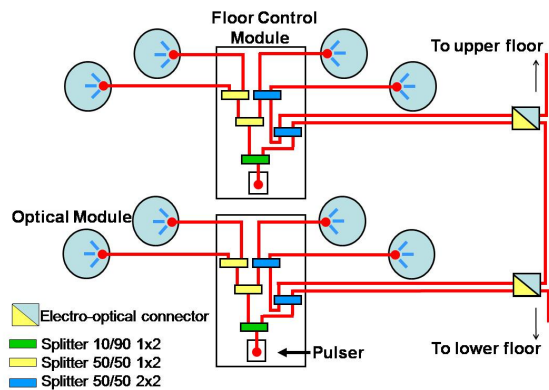

Figure 2: Layout of the time calibration system of NEMO Phase 1. A network of optical fibres (in red) distributes calibration signals from fast optical pulsers to groups of optical modules on consecutive floors.

The key element of the time calibration system is the optical pulser. The schematic of this circuit was evolved from the circuit discussed in [3]. The board features a LED Agilent HLMP CB15, which emits at blue wavelengths, as is needed, and with an aperture angle of 15° . In order to improve the light collection efficiency, the fibre is coupled to the LED by means of a commercial collimator Thorlabs F230FC-A.

Robust interfaces between the fibre and the LED as well as between the fibre and the photomultiplier have been implemented by means of precision supports. The light from the optical fibre is injected from the backside of the photomultiplier toward its photocathode, with the fibre fixed on the “neck” of the photomultiplier at an angle of about 10° with respect to its axis, chosen so as to maximize the signal amplitude.

Optical fibre Thorlabs AFS50/125 was chosen and used in Phase 1, after extensive tests of several singlemode and multimode fibres. The selected fibre is multimode with a core of $50\ \mu\text{m}$ and has a numerical aperture of 0.22. Convenient splitting ratios were chosen for the fibre network so as to ensure that signals of comparable amplitude are delivered to the different optical modules. The optical pulsers are equipped with a circuit for regulating the LED bias voltage so that it is possible to tune the intensity of the calibration pulses from the shore.

This whole system is controlled onshore by the same station which performs the GPS synchronization, clock synthesis and distribution to the whole apparatus.

For NEMO Phase 2, in order to get rid of the calibration optical fibres, the optical pulsers have been moved into the optical modules. The pulsers have been equipped with a CPLD in order to manage the communications with the calibration system. A control board, to be installed in the electronics container of each floor, will communicate with the shore and take control of the calibration operations of its floor. This board, which features a Cyclone III FPGA by Altera, is capable of measuring the communication delays for the different pulsers. Since each photomultiplier is now served by its own pulser, a high confidence in the long-term stability of these boards is mandatory. For this reason, the pulsers have been extensively tested looking for possible ageing effects. All tests performed so far give encouraging results on the feasibility of the system.

5. Conclusions

The time calibration system of NEMO Phase 1 was successfully implemented; it showed full functionality and extreme stability during the operation of the tower underwater. A revised system is under implementation for NEMO Phase 2.

Both these activities represent significant experiences toward the implementation of a km³ underwater apparatus in the Mediterranean Sea, as is currently under study within the KM3NeT consortium [4].

References

- [1] A. Capone (for the NEMO Collaboration), at this workshop.
- [2] E. Migneco et al. (the NEMO Collaboration), Nucl. Instr. Meth. A588 (2008) 111.
- [3] J. S. Kapustinski, Nucl. Instr. Meth. in Nucl. Res. A 241, 612, 1985.
- [4] <http://www.km3net.org>