



Photonic sensors for Very Large Volume Neutrino Telescopes

Mar van der Hoek¹

Nikhef, Kruislaan 409, 1098 SJ Amsterdam, Netherlands

Elsevier use only: Received date here; revised date here; accepted date here

Abstract

Since the advent of the optical fiber and the explosive development of photonic technology for telecommunications, much research has also been devoted to the development of fiber-based sensors. Today, many types of sensors and sensing principles are available for measuring a great variety of physical and chemical parameters. This paper reviews the application of photonic-and fiber- based sensors for monitoring the operational condition and structural health of a Very Large Volume neutrino Telescope (VLVnT) and its environment. Also, options for distributed sensing of marine-related parameters and geophysical phenomena in the periphery of the telescope are presented. Finally, the use of passive photonic sensors in a widely distributed network for detection of acoustic signals is described

© 2008 Elsevier Science. All rights reserved

PACS: 95.55.Vj, 42.81.Uv, 42.79.Hp, *43.60.Fg

VLVnT; photonic sensor technology, distributed sensing, fiber optic hydrophones, Optical Neutrino Telescope, Acoustic Neutrino Telescope.

1. Introduction

Fiber-based telecom networks employing advanced optical transmission technologies are the only way to fulfill the ever growing demand for world-spanning transmission of huge amounts of data at high speed. Apart from their use for data transport, optical fibers enable realization of a great number of sensor configurations, optimized to measure chemical and physical parameters [1]. Especially the use of the fiber itself as sensor opens up the wide field of distributed sensing. Today, fiber-based sensors are used in many applications, of which e.g. monitoring the internal temperature of cables for electric power transport and the distribution of strain in technical

constructions are only two examples. Measurement-based monitoring of the structural integrity and safe operation of systems are also increasingly important elements in e.g. insurance and liability affairs. Given this situation, this paper presents the role of photonic sensor technology in future VLVnTs, not only to monitor the structural health of the telescope during construction, deployment and operation, but also to enable detection of acoustic signals using a wide-area distributed network of passive fiber-based hydrophones at the seabed. In addition, sensors for geophysical and marine-related sciences can benefit from photonic and fiber based sensor technology.

¹ Corresponding Author: Tel +31 610839527; e-mail: mvdhoek@nikhef.nl

2. Fiber based sensors

Some basic configurations for fiber-based transmission-type sensors are given in figure 1.

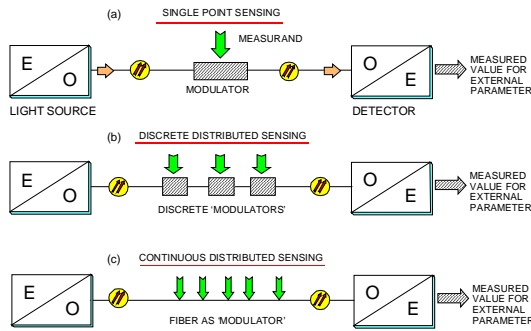

Fig. 1: Fiber-based transmission sensor configurations

Characteristic for photonic sensors is the use of a modulator to translate the parameter of interest – or measurand - into a detectable change of at least one of the optical properties of the light after passing the modulator, such as power, phase, wavelength, polarization or time of flight. Apart from having a well localized modulator or a series of distributed modulators to encode the measurand into the optical domain, the fiber itself can be used as a continuous distributed modulator, opening up a huge potential for distributed sensing of e.g. temperature and strain by using a pulsed light source and ‘echo’ detection of the measurand-modulated light, as shown in figure 2.

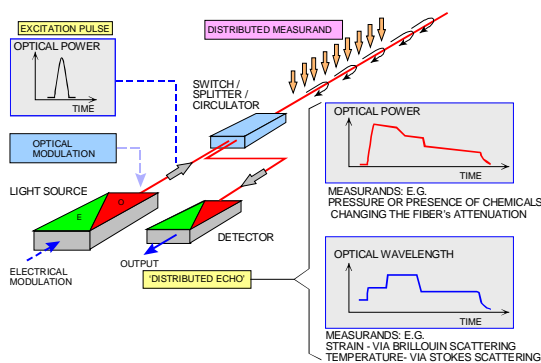

Fig. 2: Fiber-based time-domain reflectometry sensor

By nature, light-based sensing is immune to Electro-Magnetic Contamination (EMC). As the modulator and connecting fibers are electrically passive they are allowed to be located in explosive

environments, with the fiber being insensitive to corrosion. For chemical sensing, the fiber can be coated with a material modulating e.g. the optical transmission of the fiber in the presence of a single- or group- of specific gasses or liquids.

All of these technologies lead to very attractive economies of scale; large structures such as a VLVnT and its environment can be monitored using a relative low cost sensor offering many benefits over e.g. electrical based sensors in terms of reliability, safety long-distance operation and EMC issues.

3. Photonic sensors for VLVnT-condition monitoring

Application of fiber-based photonic sensors for monitoring the operational conditions of a VLVnT was first proposed at the VLVnT2003 [2,3]. As illustrated in figure 3, some first-option applications are sensing of strain in the fibers in the horizontal and vertical cabling of the submerged telescope and in the fibers of the electro-optical cable to shore, strain in construction elements of the telescope (e.g. junction box, construction elements), ingress of water in electronics compartments and temperature distribution along cables and in e.g. electronics compartments.

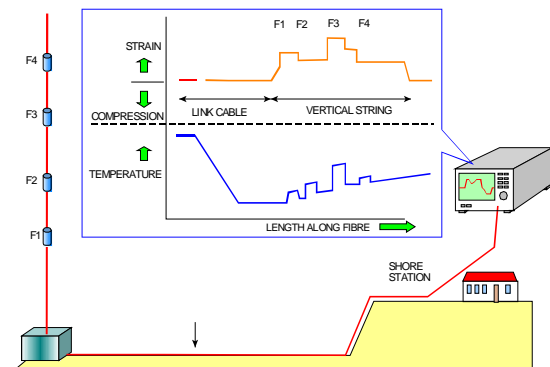

Fig. 3: Fiber-based strain and temperature sensing in a VLVnT. Inserts show examples of distributed measurements.

3.1. Fiber-based distributed strain sensing

A well-proven technique for distributed strain sensing employs pulse-echo analysis of Brillouin

scattering using a configuration as shown in figure 2. An optical pulse injected in the fiber travels down the fiber and part of the Brillouin-scattered light, being shifted in frequency by typically 11 GHz, is reflected back to the detector. For a telecom-grade of single mode fiber, the strain-induced shift in Brillouin frequency is typically 495 MHz per percent strain. Time-resolved detection of the Brillouin frequency shift reveals the local strain in the fiber and hence the strain in the object. Typically, a strain variation of 0.005% over 4m length can be detected up to a measurement range of 4 km.

3.2. Fiber-based distributed temperature sensing

Fiber-based distributed temperature sensing employs a pulse-echo technique very similar to that of strain sensing, except that here the Raman pulse height is analyzed to retrieve the local temperature of the fiber. This technique offers a typical temperature resolution and accuracy of respectively 0.1 °C and 1 °C, 1m spatial resolution and up to 80 km measuring range.

3.3. Fiber Bragg Grating-based sensing

In contrast to continuous distributed sensing, point-sensing of strain and temperature is possible using Fiber Bragg Gratings (FBG) in a configuration as shown in figure 4.

A FBG consists of a periodic structure of multiple weakly reflecting planes being ‘written’ in the core of an optical fiber. Illuminated with broadband light, a FBG will reflect a wavelength satisfying the condition:

$$\lambda = 2n\Lambda, \quad (1)$$

with Λ being the periodicity of the grating and n the refractive index of the fiber core material between the grating planes. For a FBG being bonded to an object or embedded into it, a temperature- or strain-induced change in the geometry of the object changes Λ as well as n and hence the reflected wavelength with typically 1.1 pm/microstrain (=1 μ m elongation per m) and 10 pm/K.

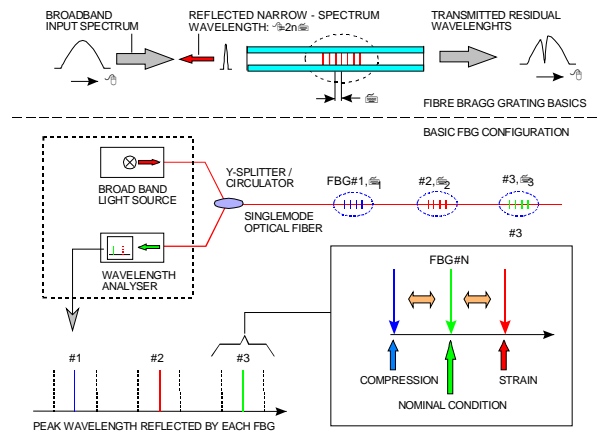

Fig. 4: Fiber-Bragg Grating based sensing

Hence, by analyzing the reflected wavelength the strain in the FBG or its temperature can be determined. Coating the FBG with a measurand-specific jacket results in e.g. a selective response to chemicals or just water. For discrete distributed measurements, multiple FBGs are put in series on a single fiber and read-out by a central unit. Arrays of passive FBG-based sensors can be located at a large distance from the readout unit. Due to wavelength encoding, readout of FBGs is immune to external influences along the fiber link between sensors and the read-out unit. Also, readout requires only a single fiber for illumination and read-out of FBGs, being ideal for distributed sensing of a multitude of parameters in a VLVnT and its environment.

4. Photonic sensors for VLVnT environment monitoring

Reliable long-term operation of a VLVnT requires not only a well proven and robust design of the telescope but also a stable geophysical and marine environment. Also, the periphery around the telescope can be monitored on e.g. marine-related parameters like e.g. salinity, algae population, bioluminescence and temperature. In addition, photonic sensors also enable efficient distributed sensing of e.g. seabed deformations and early signs of tectonic activity, using fiber-based geophones and sensor cables as depicted in figure 5.

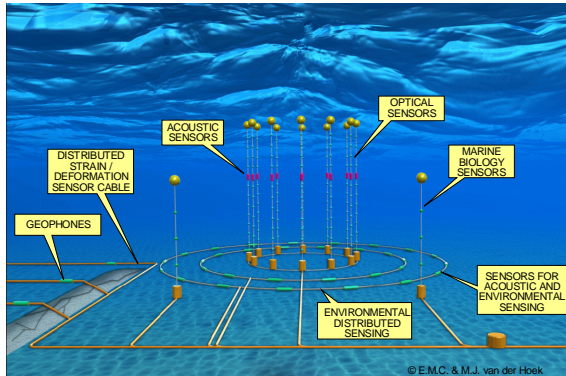

Fig. 5: Artist impression of photonics in a VLVnT for condition monitoring and detection of acoustics, marine related parameters and seabed activity. Note: configuration of the telescope is only for indicative purposes

Here, fiber-based sensor cables are pinned to the seabed or trenched into it and photonics-based geophones detect tectonic activity. Also depicted are dedicated photonic sensors for e.g. chemical sensing, water flow velocity and marine biology research.

Detection of acoustic signals is possible using fiber-based interferometers according to figure 6. Due to differential action, the acoustic pressure induces a small phase difference between the sensing and reference branch. After recombination by the directional coupler, these phase differences result in well defined optical power variations being detected and converted into the electrical domain. These hydrophones are completely passive and arrays of sensors can be put in series on a single fiber. Readout of the hydrophones is done using a common light source and advanced detection technique to interrogate the individual interferometers. These array configurations offer the potential for realizing large detection volumes on a cost efficient basis. Ongoing improvements in the performance of fiber-based hydrophones as presently used for e.g. deep-sea submarine detection are approaching or even fit the requirements for acoustics-based neutrino detection, depending on the frequency ranges of interest.

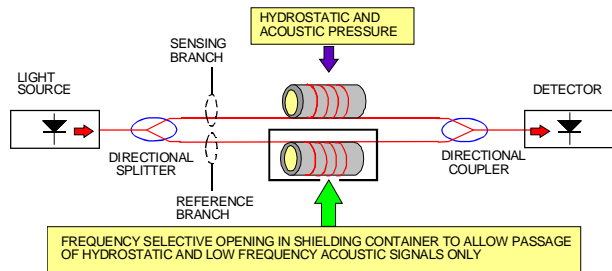

Fig. 6: Fiber-based hydrophone for detection of acoustic pressure variations and compensation for hydrostatic pressure.

5. Future outlook

Already now photonic sensors offer a huge potential for advanced sensing. Integration of photonic sensors in future VLVnTs will enable monitoring of its structural parameters during production, deployment and operation. Also, physical and chemical parameters related to the marine environment and seabed activity can be measured efficiently using arrays of passive discrete sensors or passive sensor cables for distributed measurements.

Photonic technology for data transmission combined with multi-parameter advanced sensing will enable cost-effective volume expansion of future VLVnTs towards a multifunctional sensing-platform.

Acknowledgments

This work is part of the research program of the 'Stichting voor Fundamenteel Onderzoek der Materie (FOM)', which is financially supported by the 'Nederlandse Organisatie voor Wetenschappelijk Onderzoek (NWO)'.

References

- [1] J.M. López-Higuera, Handbook of Optical Fibre Sensing Technology, John Wiley and Sons, LTD, 2002, ISBN 0-471 82053 9.
- [2] Proceedings of The workshop on Technical aspects of a VLVnT in the Mediterranean Sea ISBN90-6488-026-3
- [3] M. van der Hoek, Data Transmission, VLVnT 2003 (<http://www.vlvnt.nl/talks/P3/>)