

TI-LGAD developments at LPNHE

B. Raciti | FCC Meeting, 21st May 2026

Goals and current developments

A variety of *trench-isolated* LGADs (TI-LGADs) with **different geometries** have been produced:

- several trench widths and depths
- different sensor thicknesses
- guard ring designs

Idea:

- test with laser TCT in the lab
- best-performing sensors measured at test beam

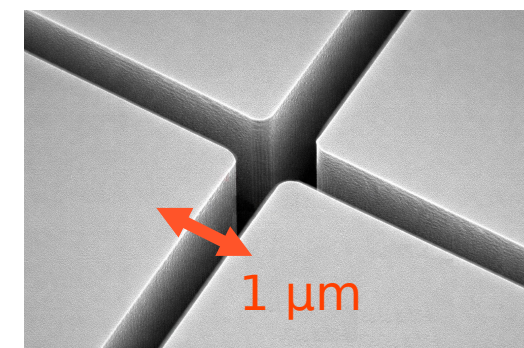
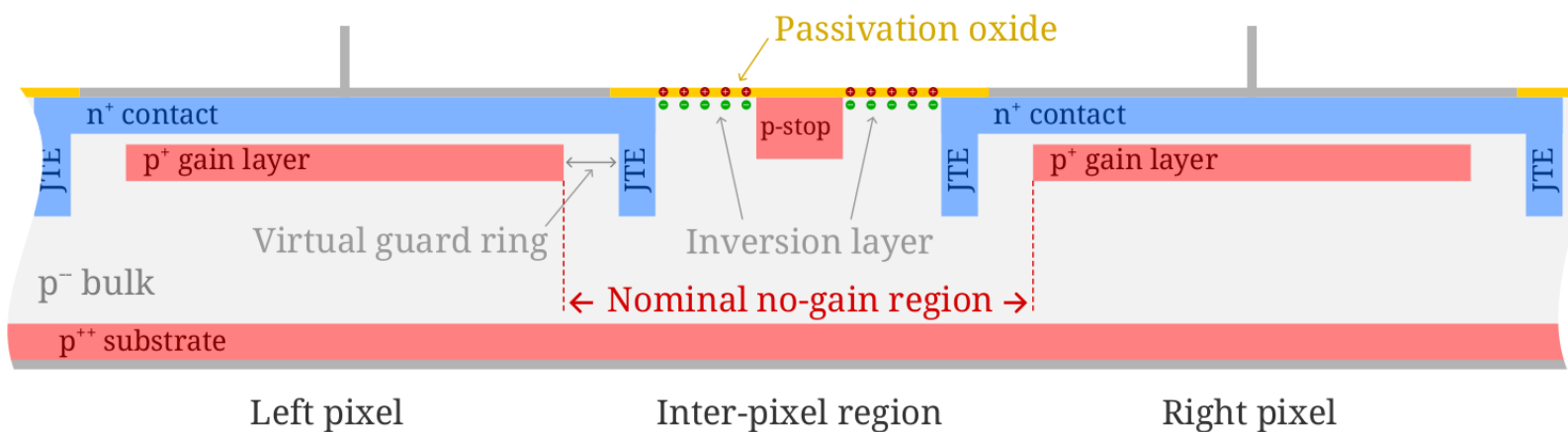

TCT setup

Working principle:

- laser deposits charge in sensor and *triggers* waveform acquisition
- signal output is propagated with delays to oscilloscope

Different measurements are possible:

- evaluation of inter-pixel gain region
- time resolution (no landau contributions)

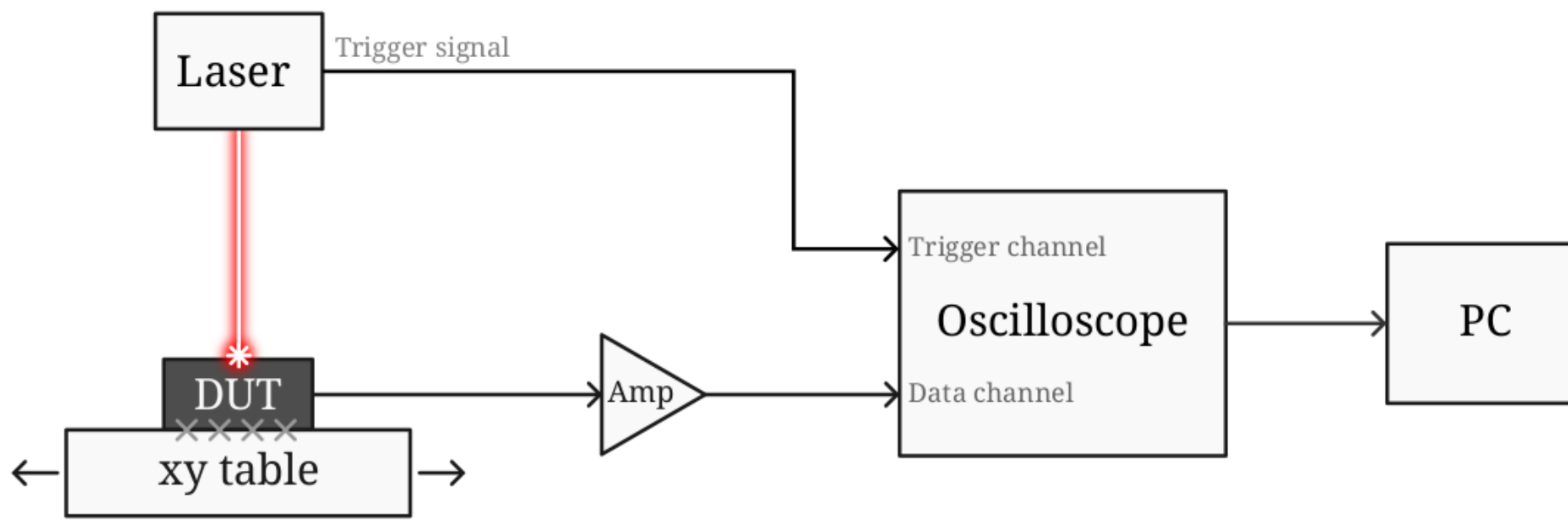

TCT setup

Working principle:

- laser deposits charge in sensor and *triggers* waveform acquisition
- signal output is propagated with delays to oscilloscope

Different measurements are possible:

- evaluation of inter-pixel gain region
- time resolution (no landau contributions)

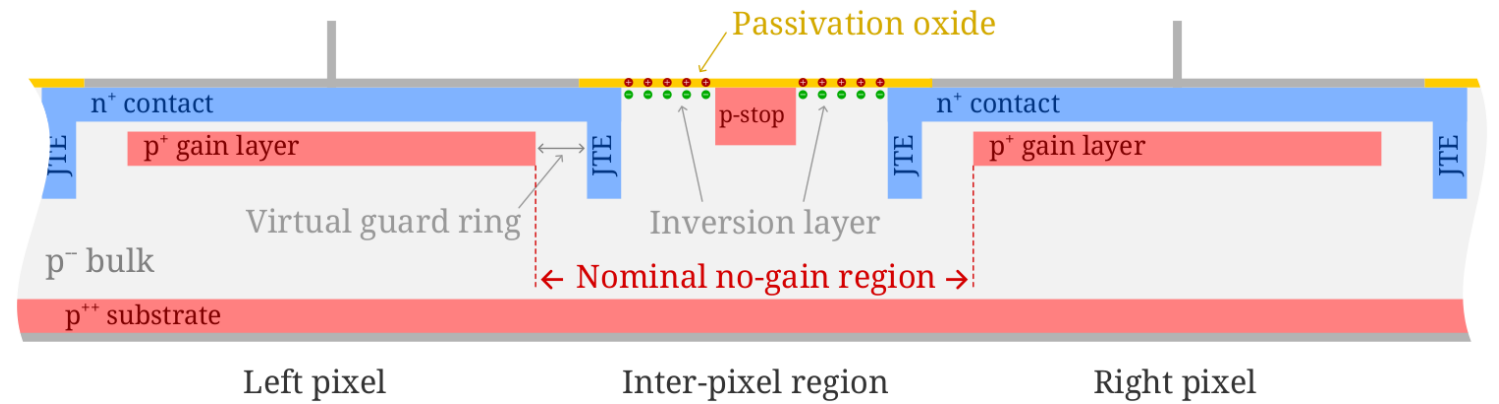
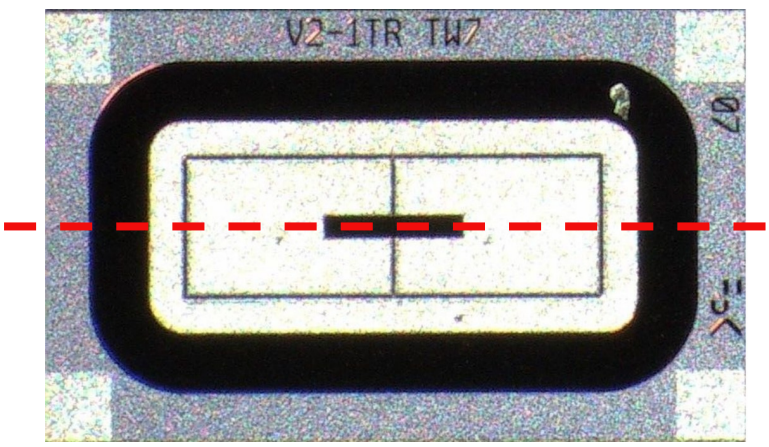
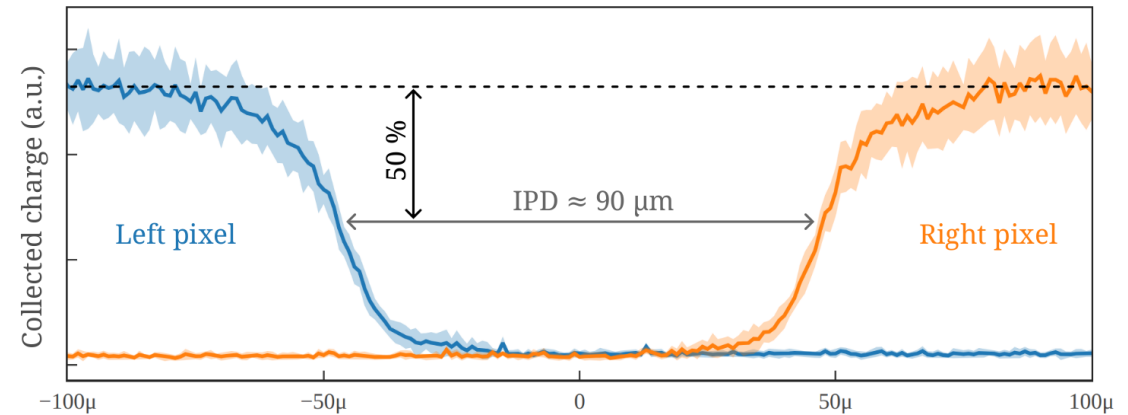

TCT setup

Working principle:

- laser deposits charge in sensor and *triggers* waveform acquisition
- signal output is propagated with delays to oscilloscope

Different measurements are possible:

- evaluation of inter-pixel gain region
- time resolution (no landau contributions)

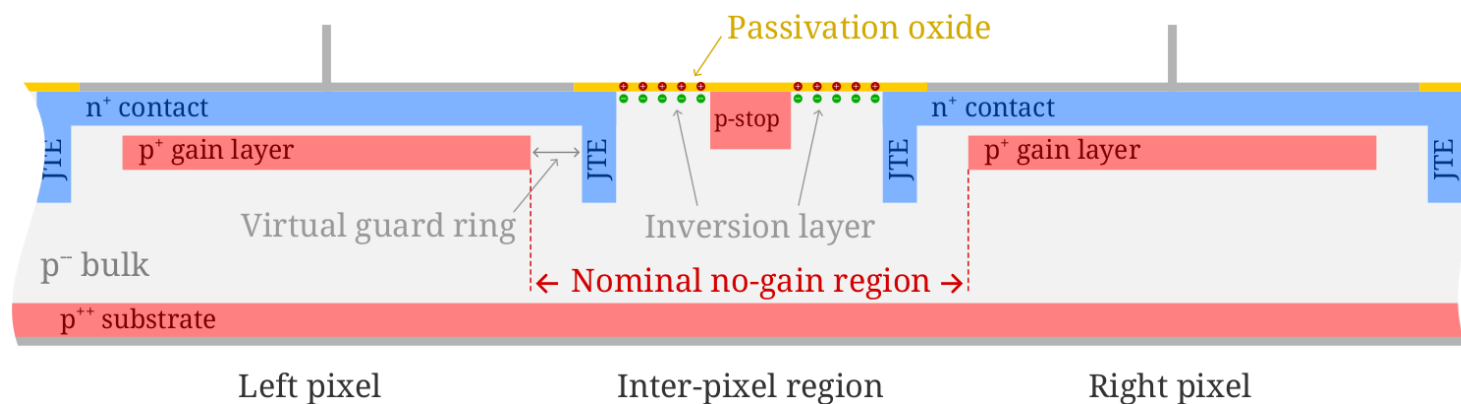
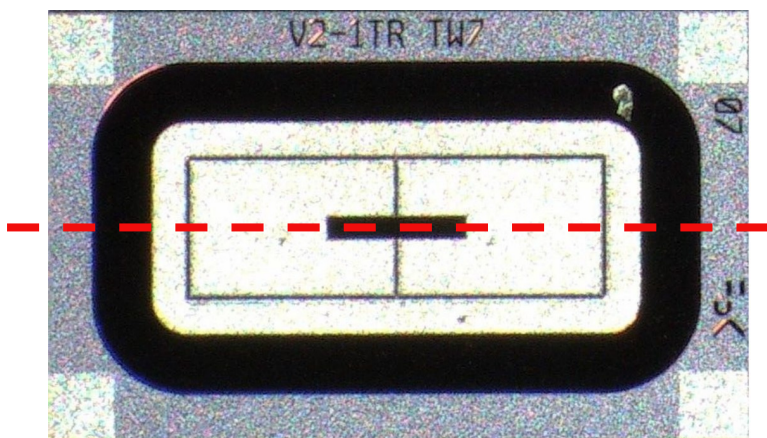
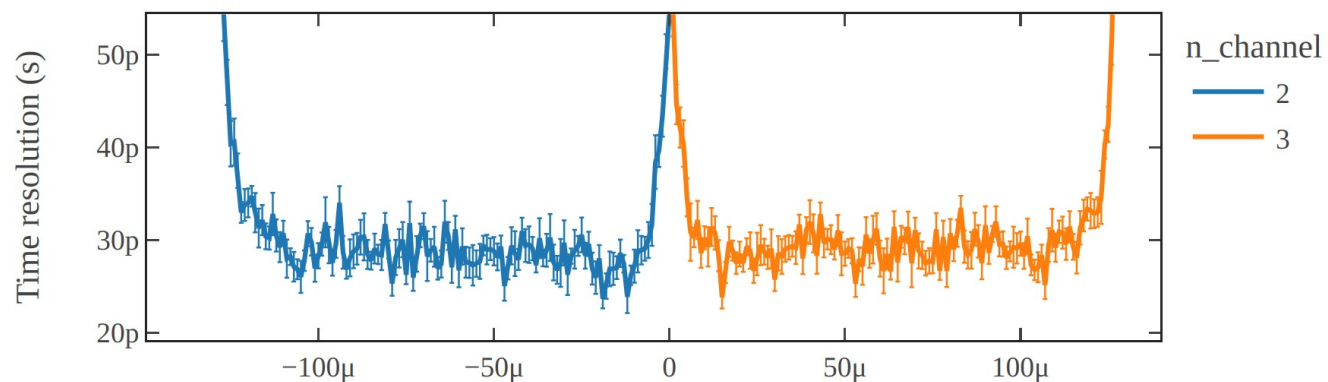

TCT setup

Status:

- x-y stage is working and can be piloted from PC
- IMPORTANT! LGADs and readout board have arrived at LPNHE!
 - IV curves and simple test for signal acquisition with TCT

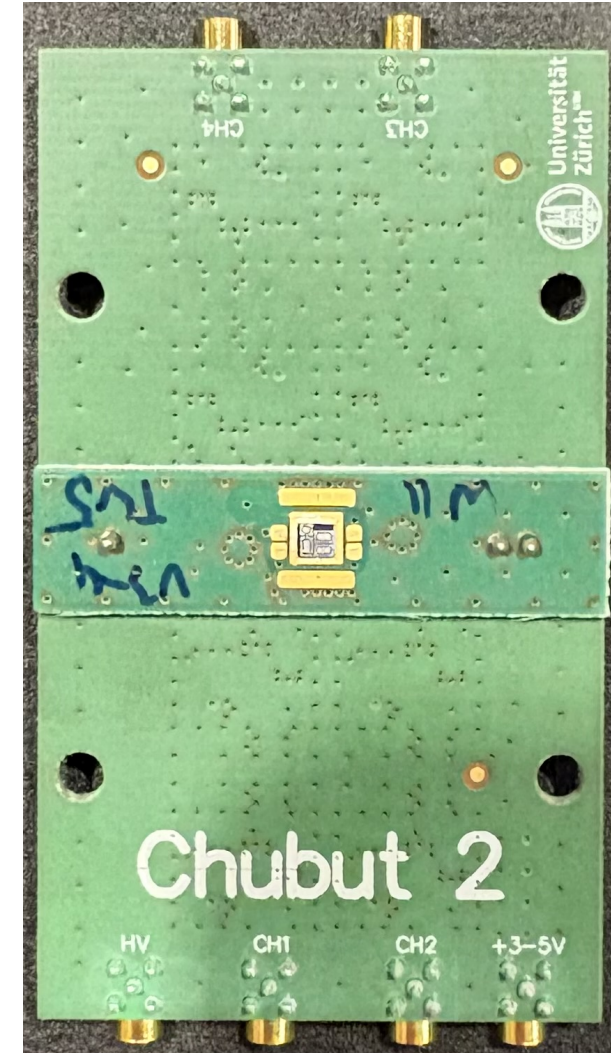
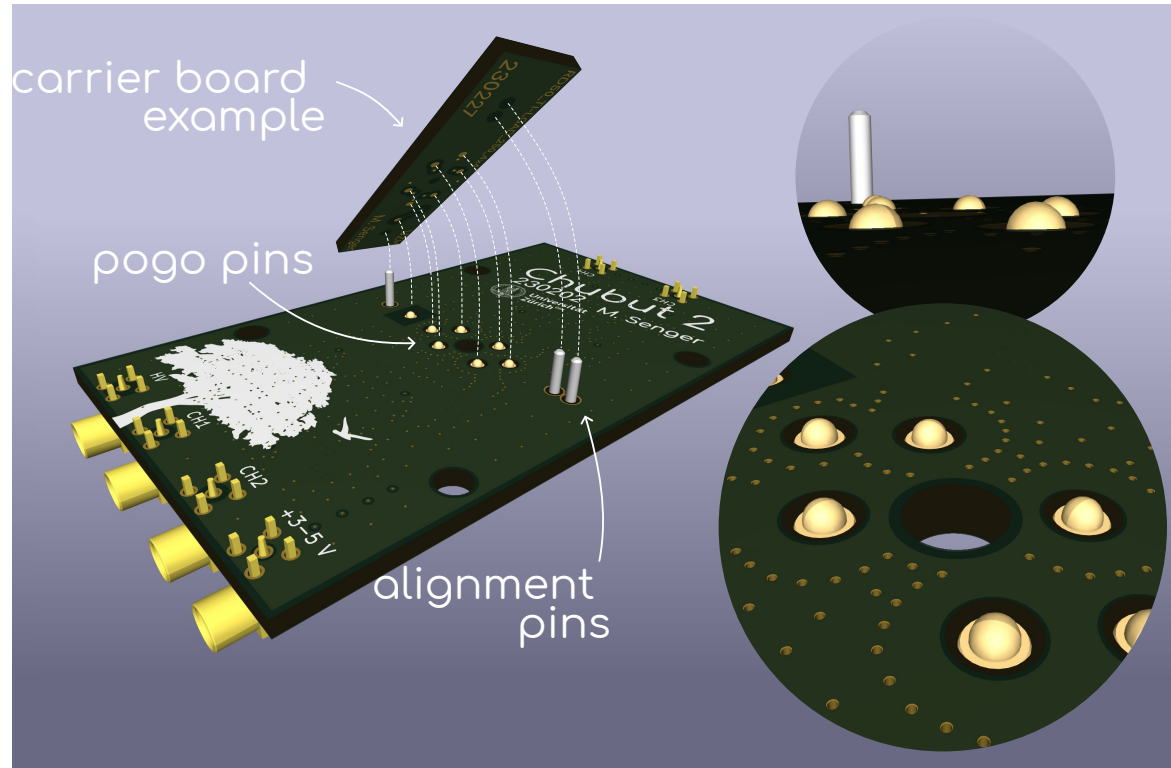

TI-LGAD simulation

Giorgia and Lounes actively working on **simulation**:

- NOTE: exact details of geometry are unknown → will be discussed soon
- our “educated guess” lead to promising results
 - IV curve, signal, impact ionization and gain

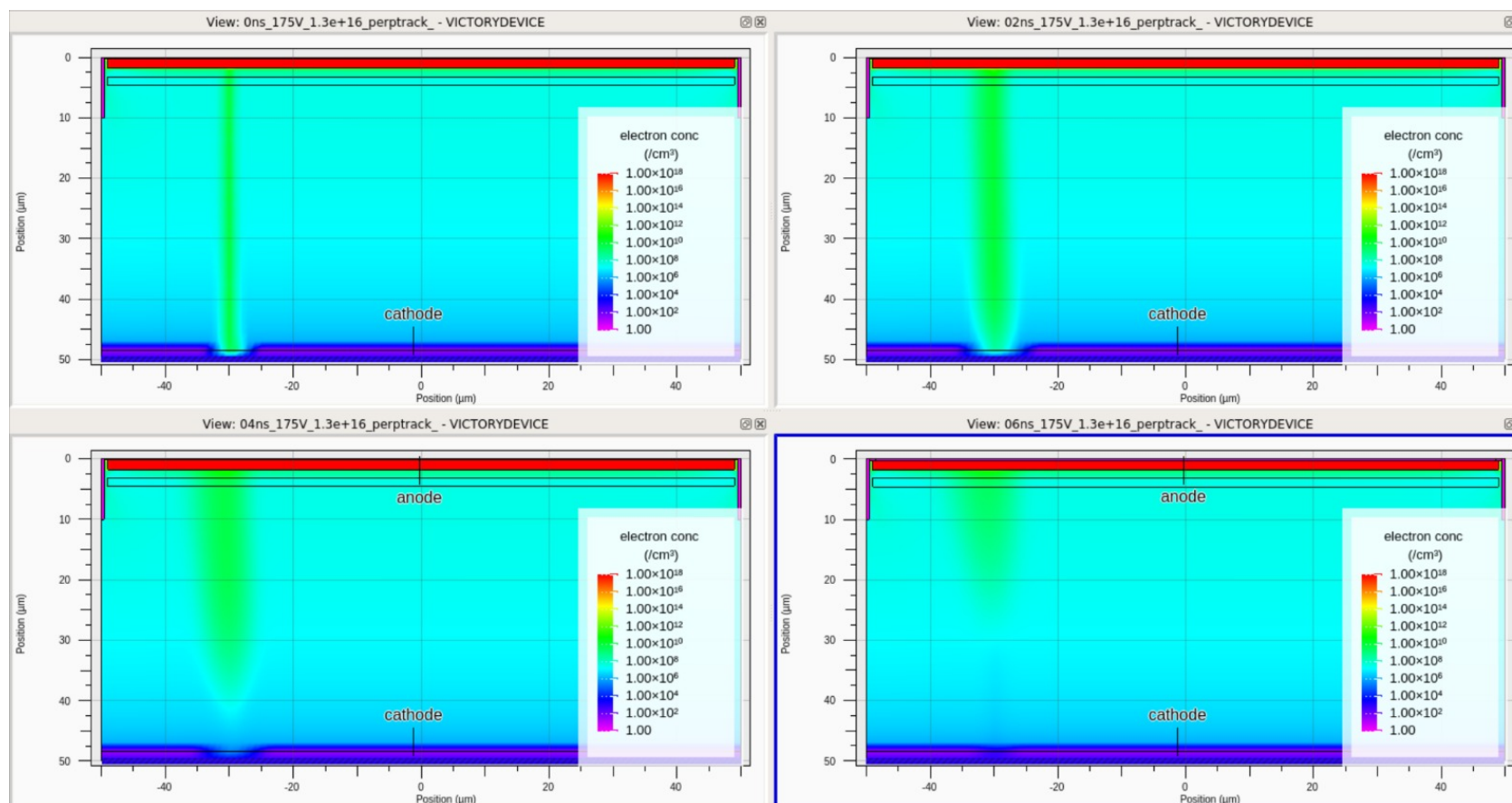

TI-LGAD simulation

Giorgia and Lounes actively working on **simulation**:

- NOTE: exact details of geometry are unknown → will be discussed soon
- our “educated guess” lead to promising results
 - IV curve, signal, impact ionization and gain

IV curves

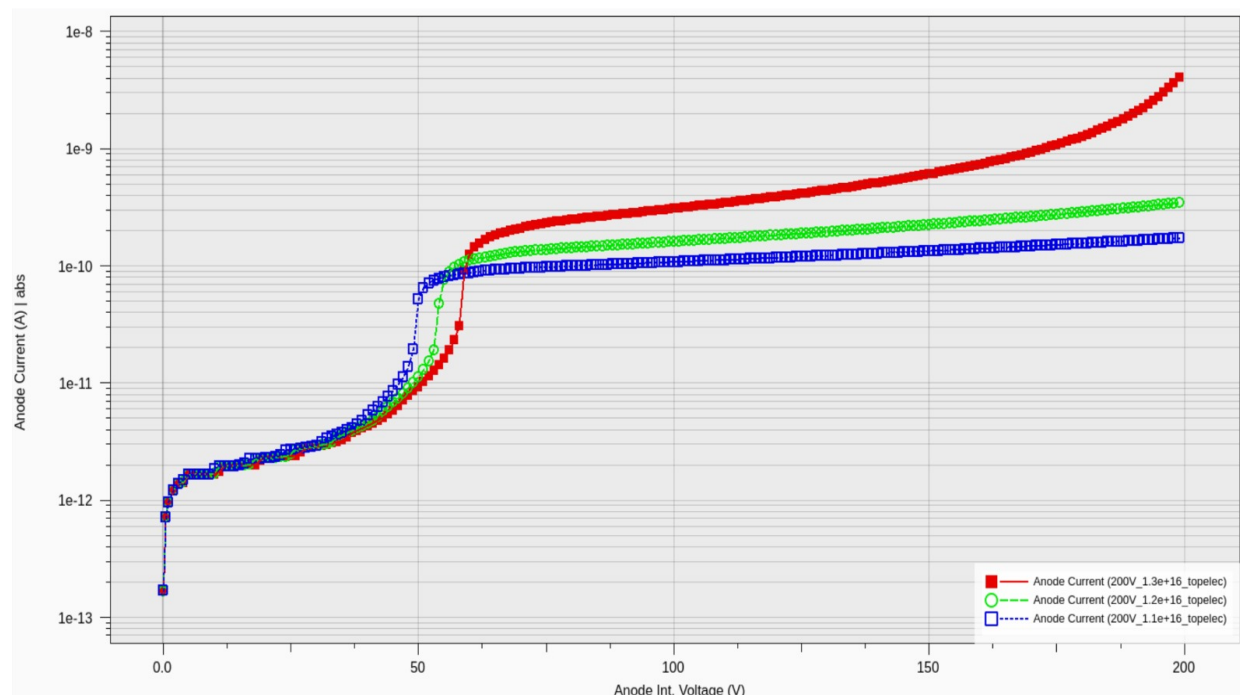

current signal

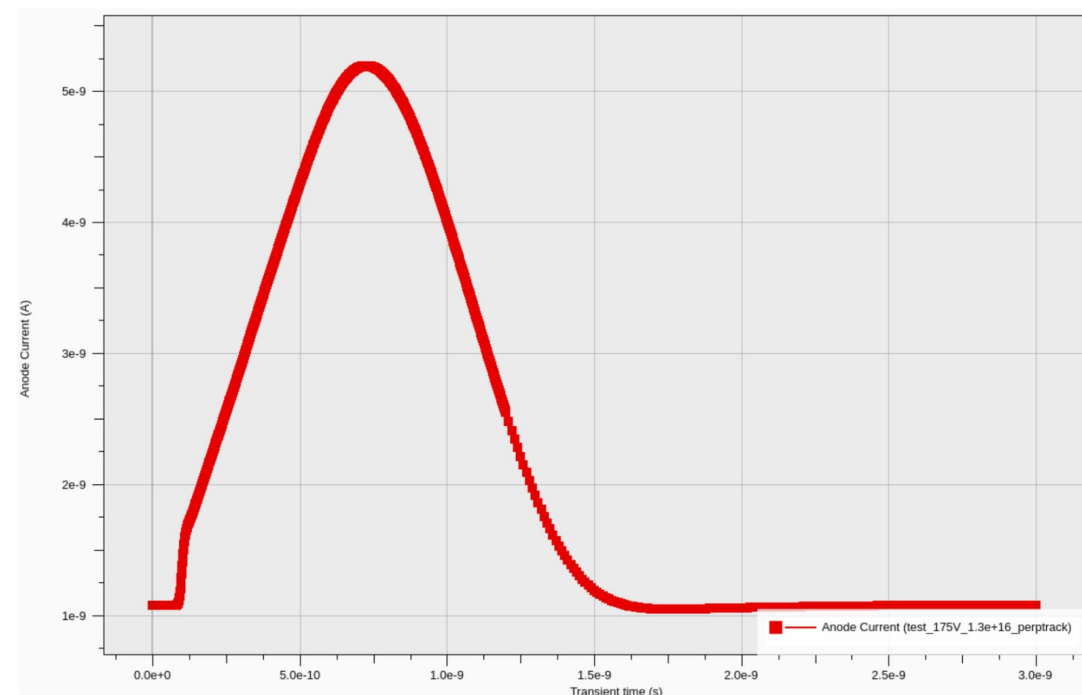

Test beam: data analysis and results

Test beam effort in March:

- circa 3 Tb of data!
- all softwares for analysis installed → efficiency and not time resolution (for the moment)

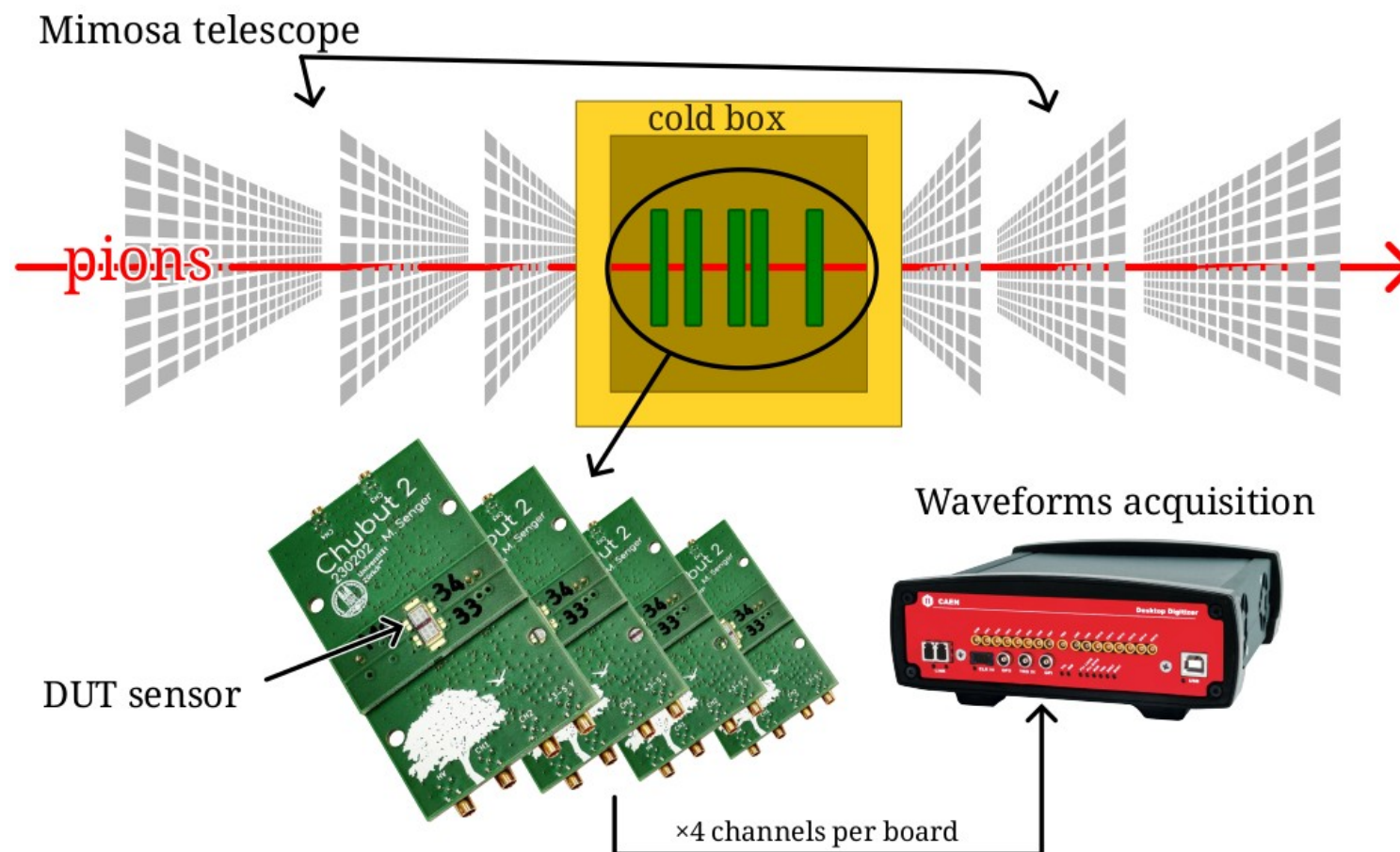

Test beam: data analysis and results

Test beam effort in March:

- circa 3 Tb of data!
- all softwares for analysis installed → efficiency and not time resolution (for the moment)

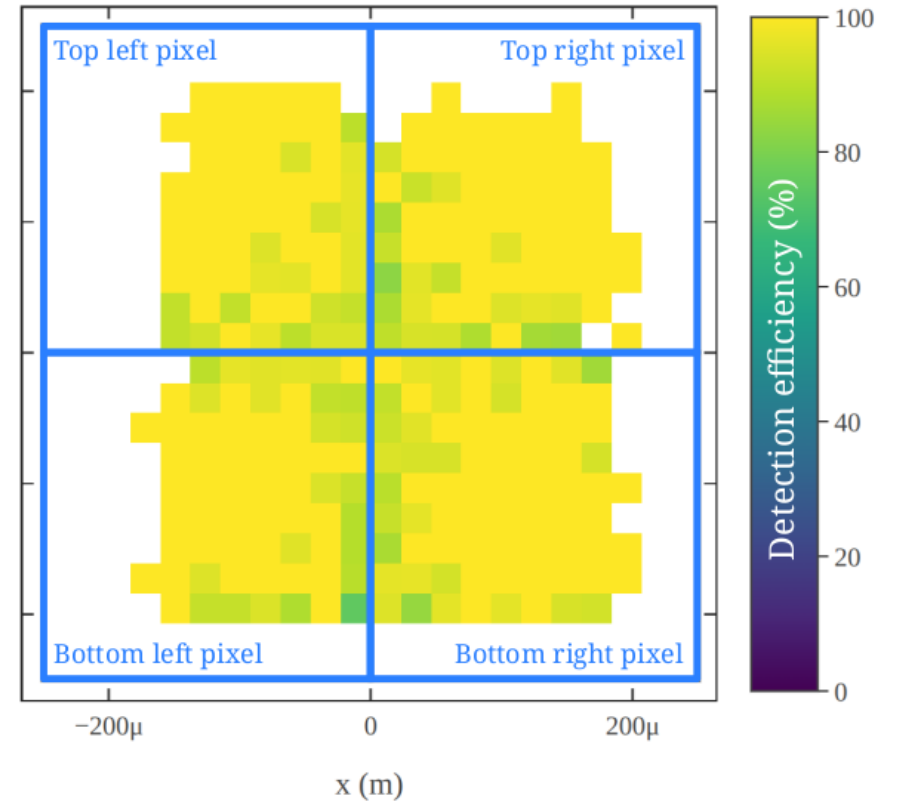
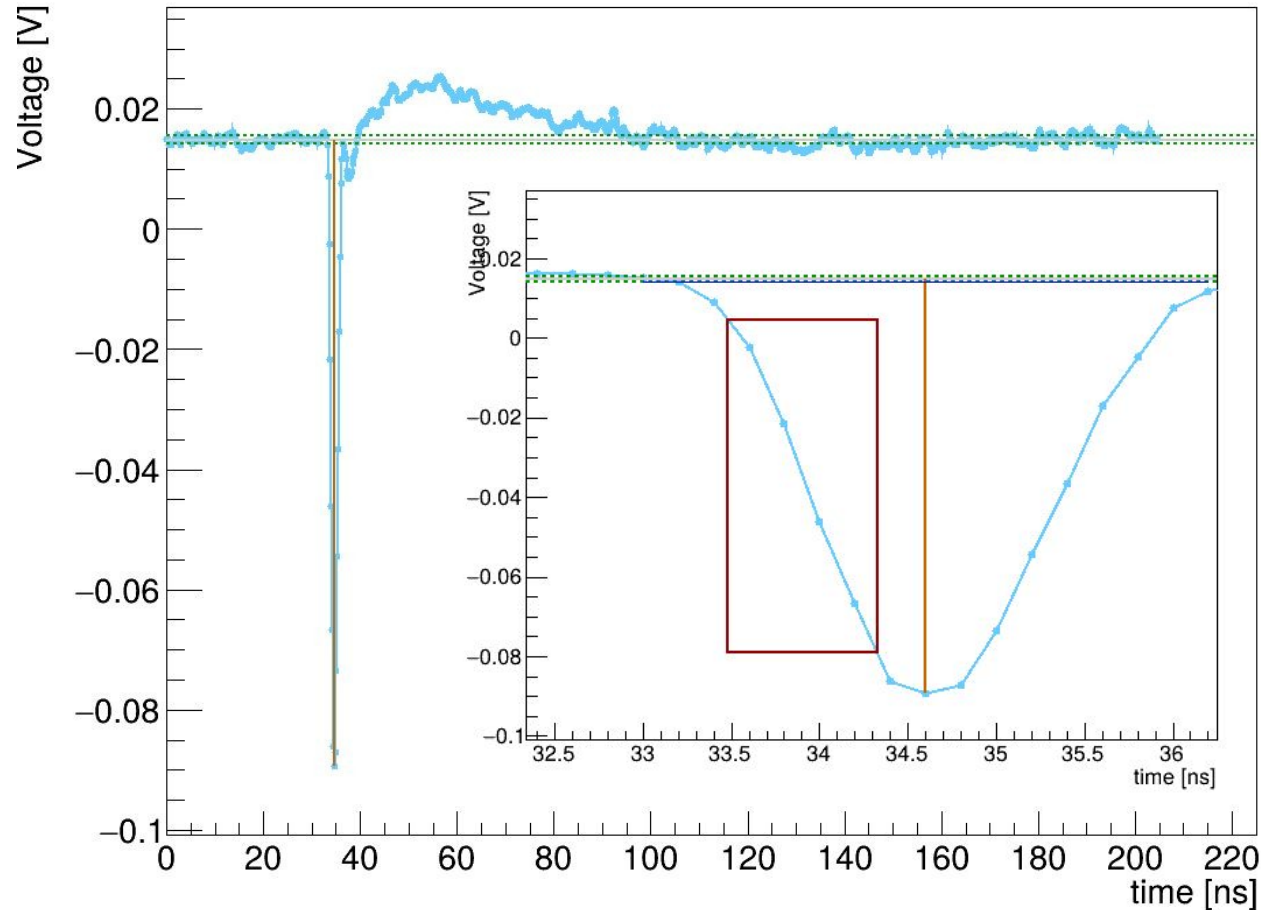

Test beam: data analysis and results

Test beam effort in March:

- circa 3 Tb of data!
- all softwares for analysis installed → efficiency and not time resolution (for the moment)

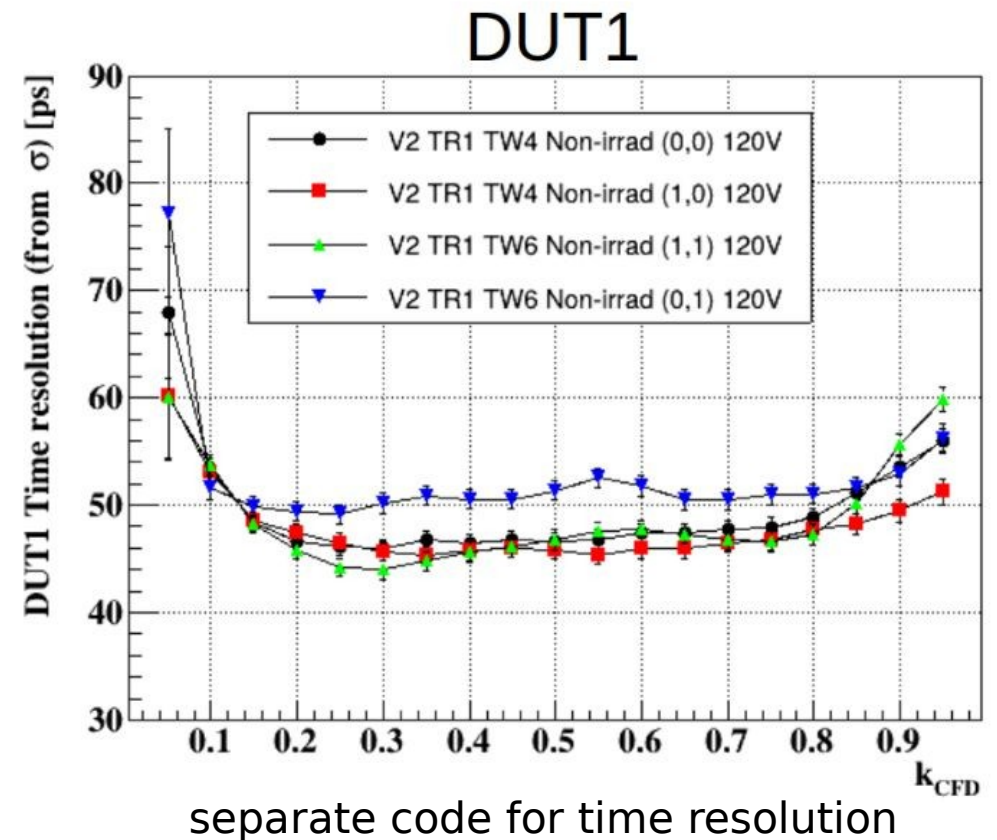
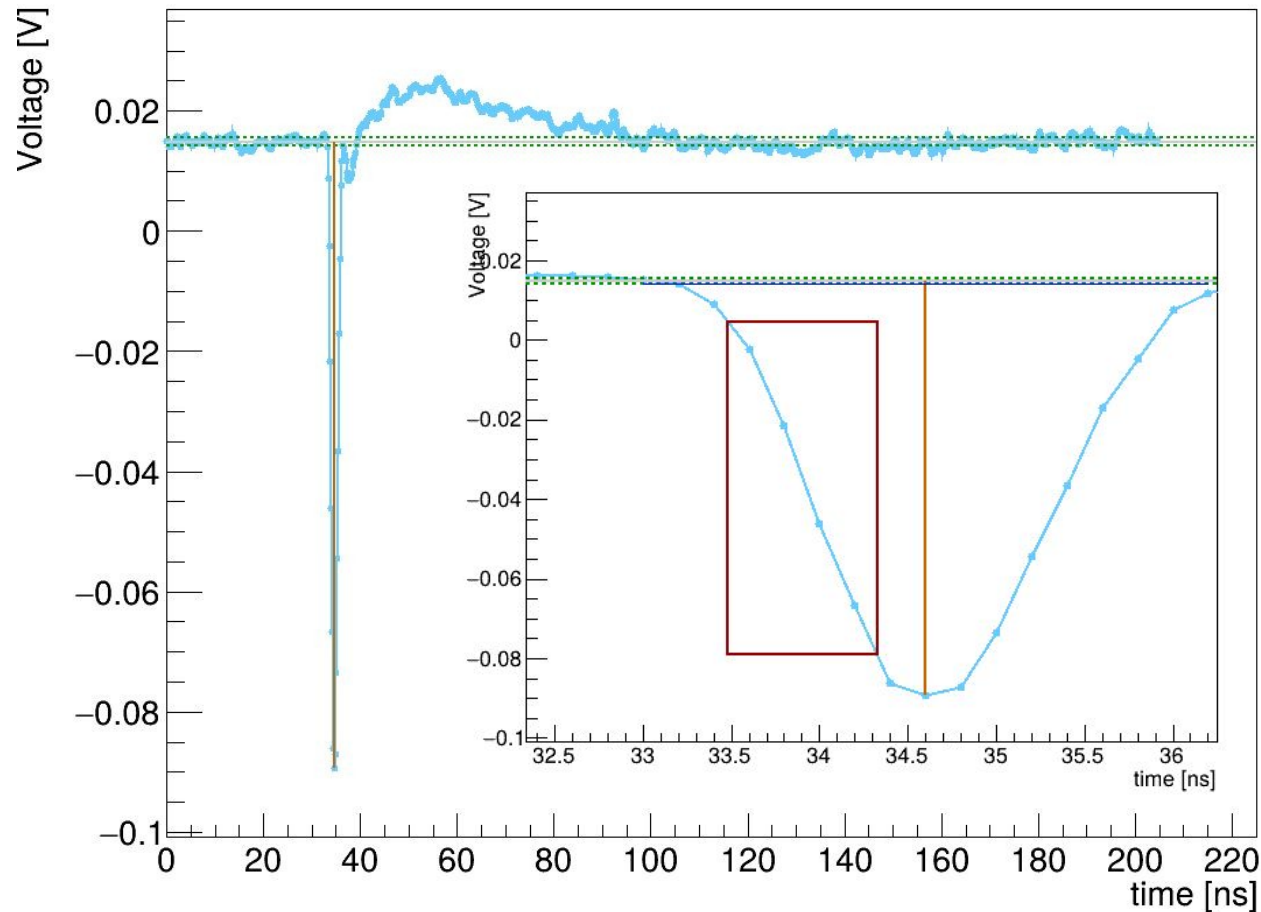

Backup

kCFD: constant fraction discrimination

Technique used to map big and large signals to a common reference shape:

- reduce impact of Landau noise

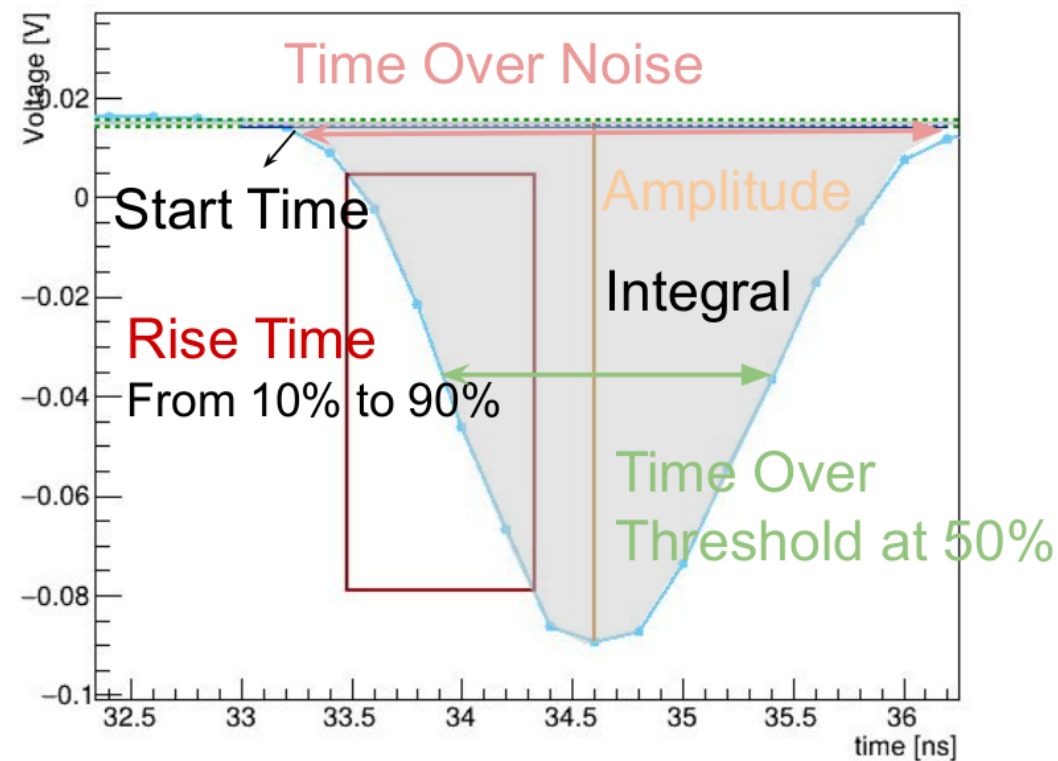
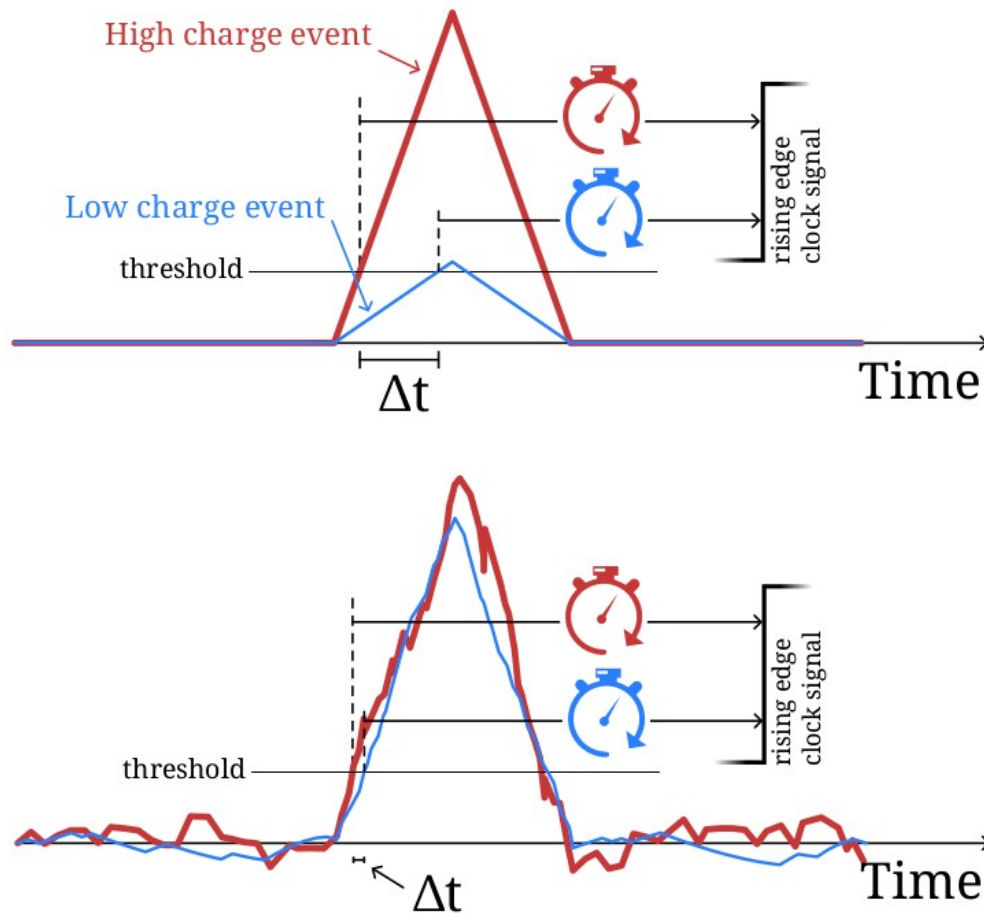

Another problem: noise sources

Most important factors contributing to temporal resolution σ_t :

- $\sigma_t^2 = \sigma_{\text{jitter}}^2 + \sigma_{\text{Landau}}^2 + \sigma_{\text{time-walk}}^2 + \sigma_{\text{distortion}}^2 + \sigma_{\text{TDC}}^2$
 - σ_{Landau} and $\sigma_{\text{time-walk}}$: non-uniform energy deposition by impinging particles
 - σ_{jitter} : electronic noise
 - $\sigma_{\text{distortion}}$: non-saturated drift velocity (non-uniform weighting field) → negligible
 - σ_{TDC} : finite size of TDC bins

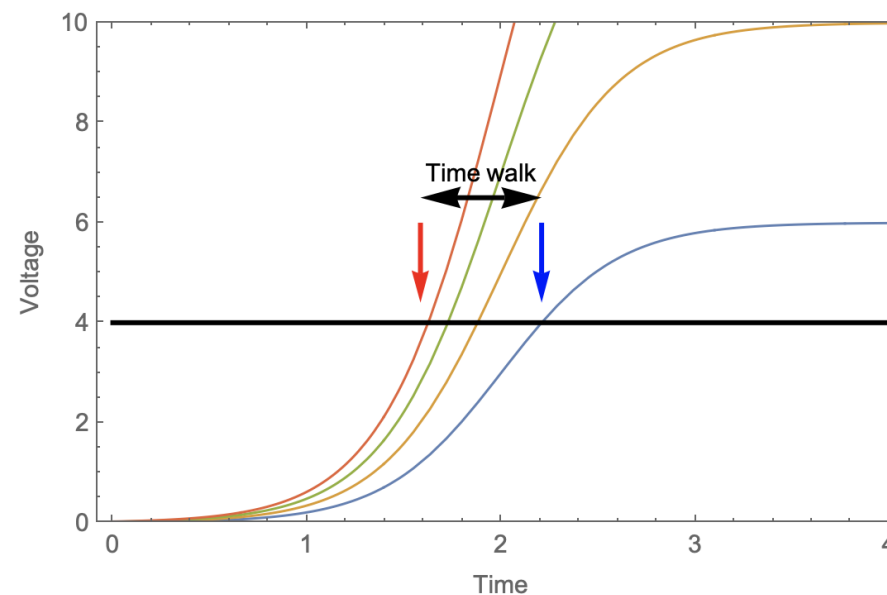
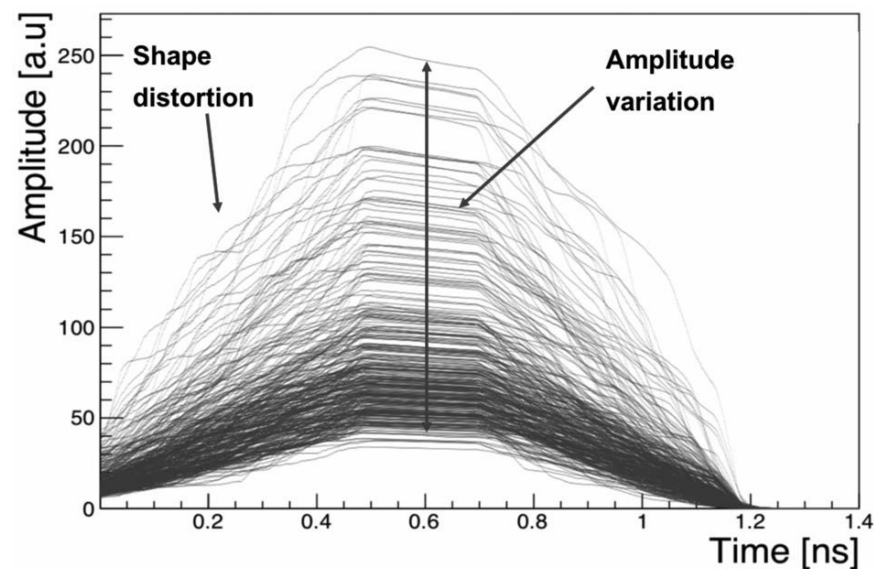

Another problem: noise sources

Most important factors contributing to temporal resolution σ_t :

- $\sigma_t^2 = \sigma_{\text{jitter}}^2 + \sigma_{\text{Landau}}^2 + \sigma_{\text{time-walk}}^2 + \sigma_{\text{distortion}}^2 + \sigma_{\text{TDC}}^2$
 - σ_{Landau} and $\sigma_{\text{time-walk}}$: non-uniform energy deposition by impinging particles
 - σ_{jitter} : electronic noise
 - $\sigma_{\text{distortion}}$: non-saturated drift velocity (non-uniform weighting field) \rightarrow negligible
 - σ_{TDC} : finite size of TDC bins

