

Sensitivity studies for neutrino oscillation parameters measurement and time synchronisation system for the Hyper-Kamiokande experiment

NU_09 project



Claire Dalmazzone, TYL/FJPPN Young Investigation Award Ceremony, Monday May 18th



The Hyper-Kamiokande experiment

Hyper-Kamiokande

From Kamiokande to Hyper-Kamiokande



- **Kamiokande** detected ~10 neutrinos from the supernova **SN1987A**
- **Super-Kamiokande** has been running since 1996 and notably lead to the **discovery of neutrino flavour oscillation in 1998**
- **Hyper-Kamiokande:** same principle but **~8 times larger volume!**
- The construction is ongoing and data-taking will start in **2028**

Hyper-Kamiokande

Physics program

Astrophysics

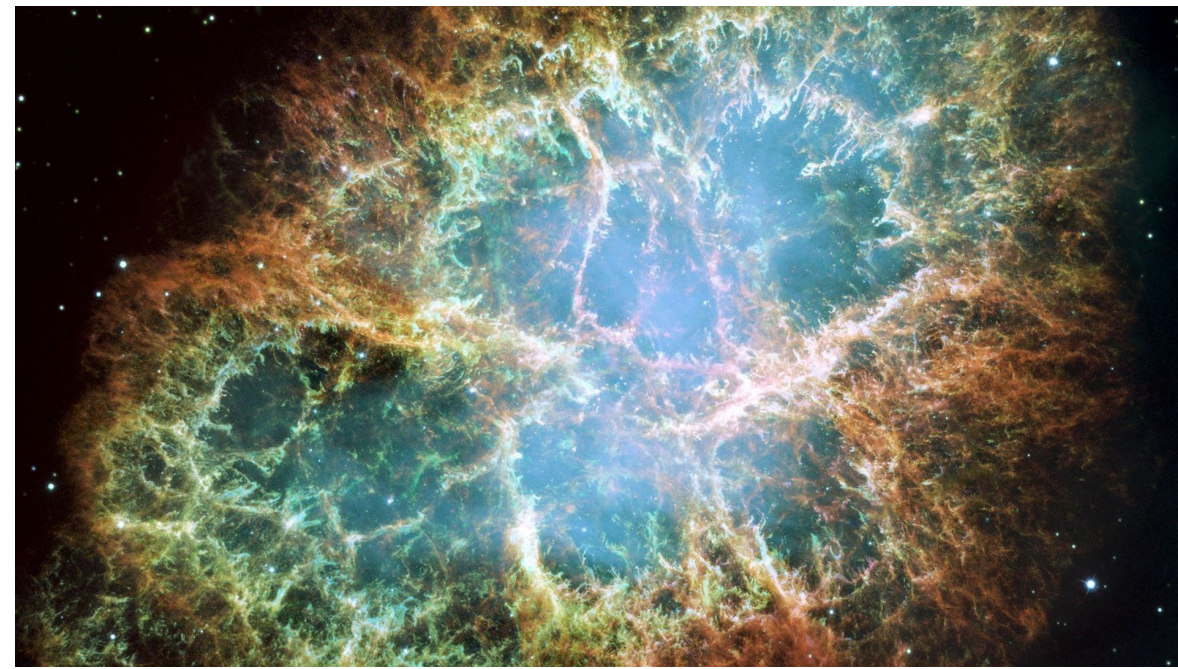

Supernovae neutrinos

Solar neutrinos



Flavour oscillation

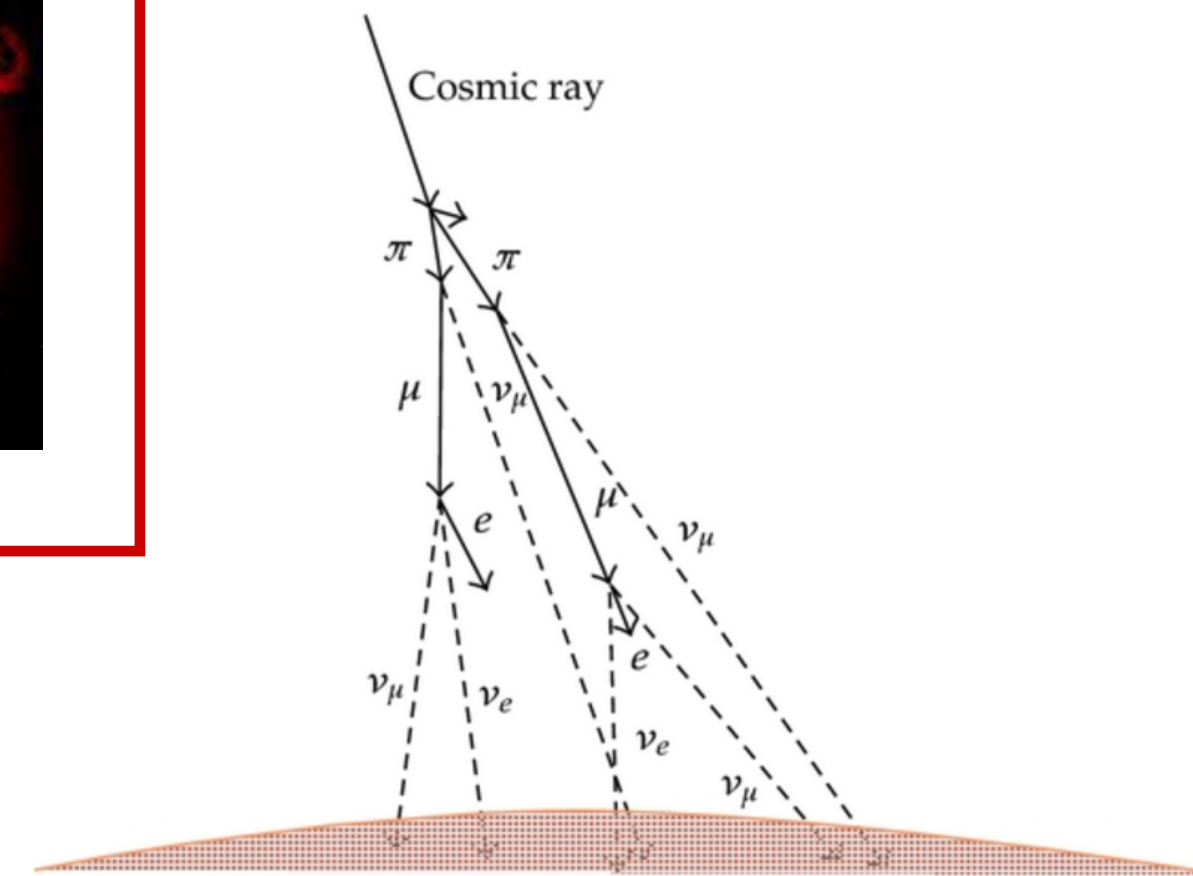
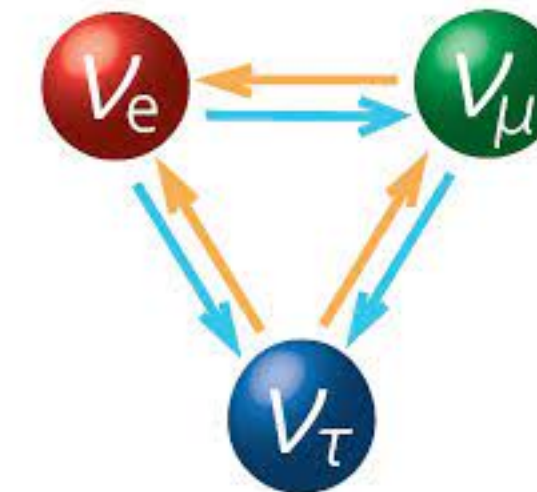

Atmospheric neutrinos

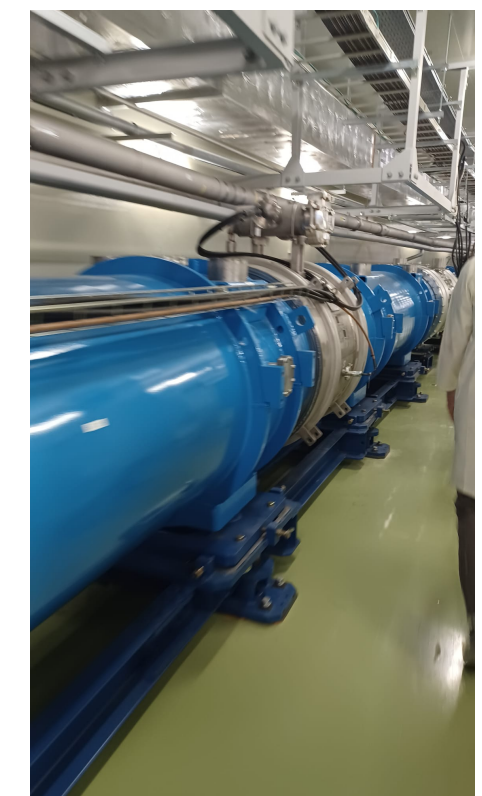

Accelerator neutrinos (long baseline or LBL program)

Main focus of the presentation

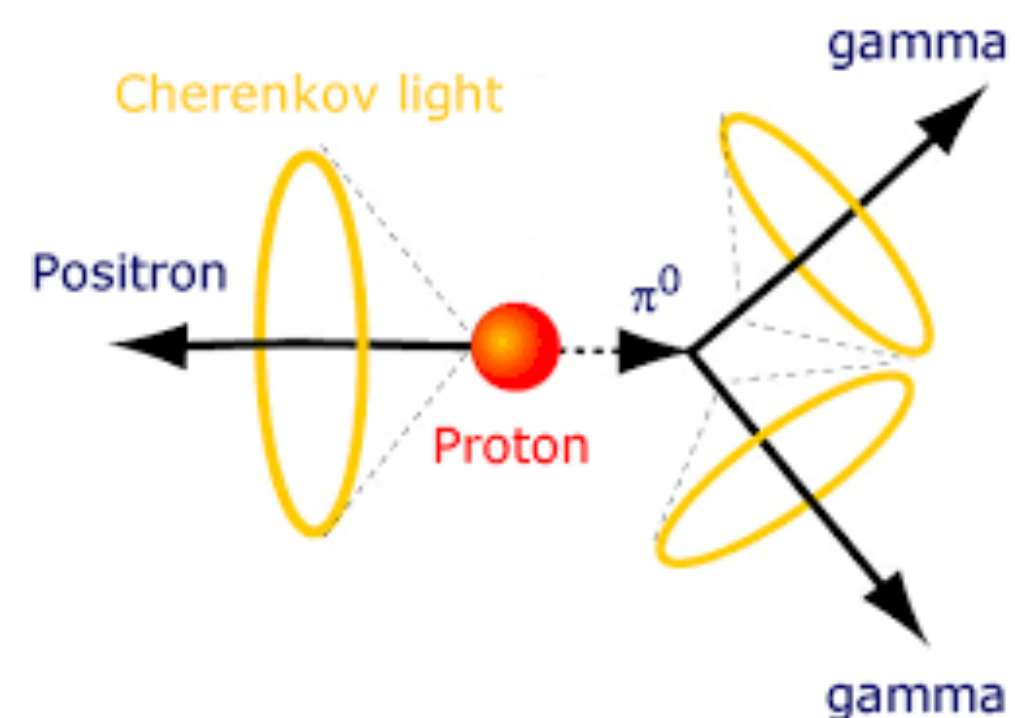

Nucleon decay search
Historical purpose of
Kamiokande

Long baseline program

Overview

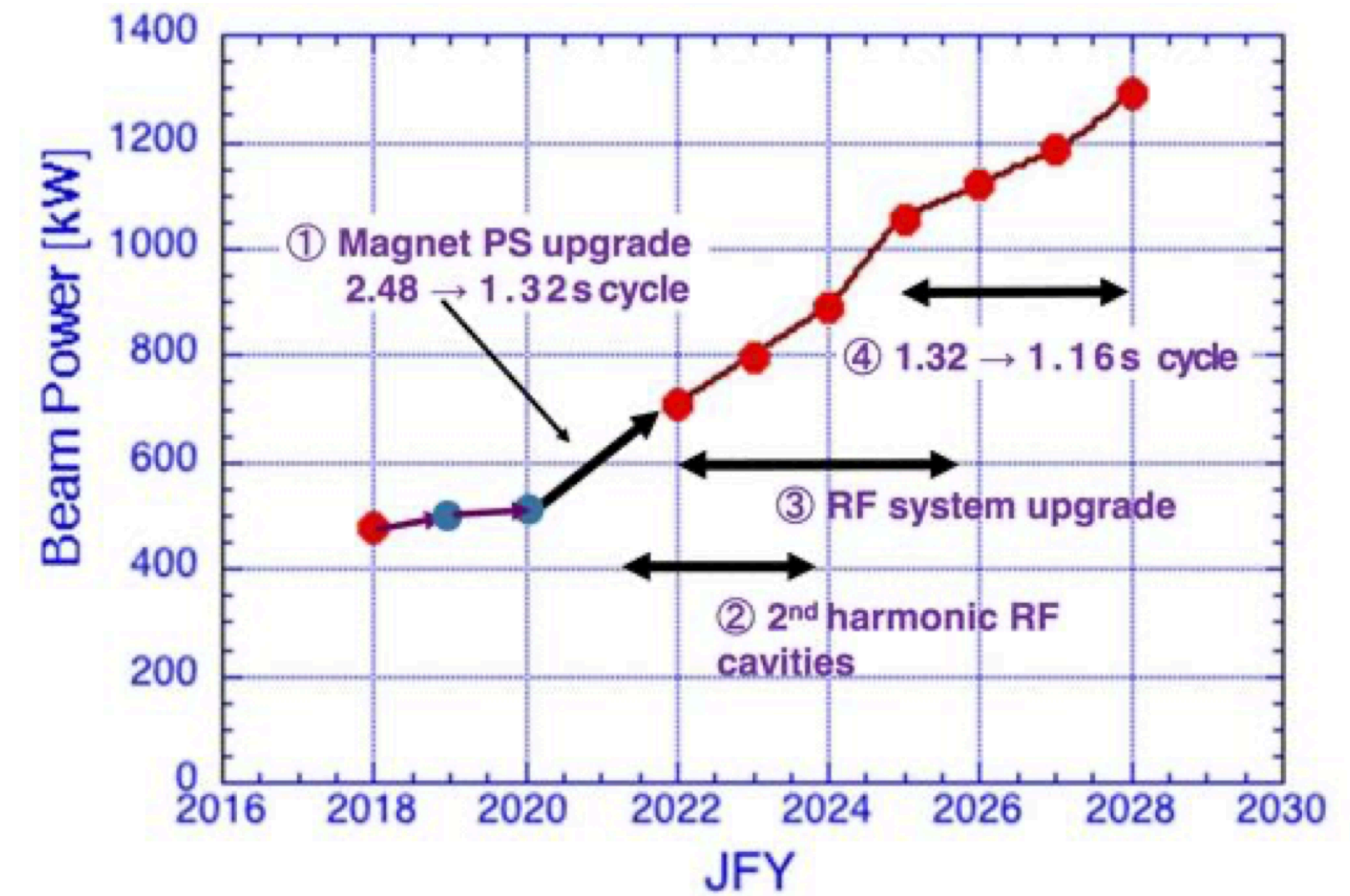
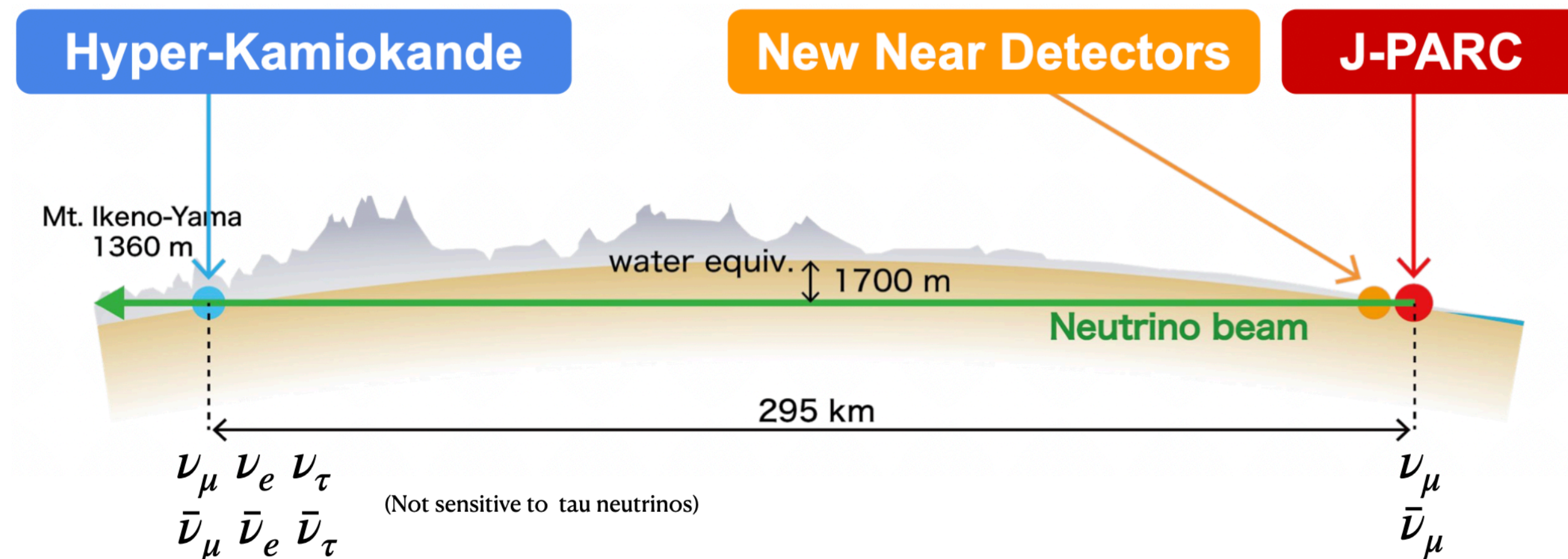

Credit: Megan Friend, NuFact 2021

Will re-use the T2K beam line with some upgrades:

ν_μ ($\bar{\nu}_\mu$) beam produced at **J-PARC accelerator facility**

Accelerator **upgrades to increase beam power** (from 500 kW in 2020 to 1.3MW in 2028)

Long baseline program

Overview

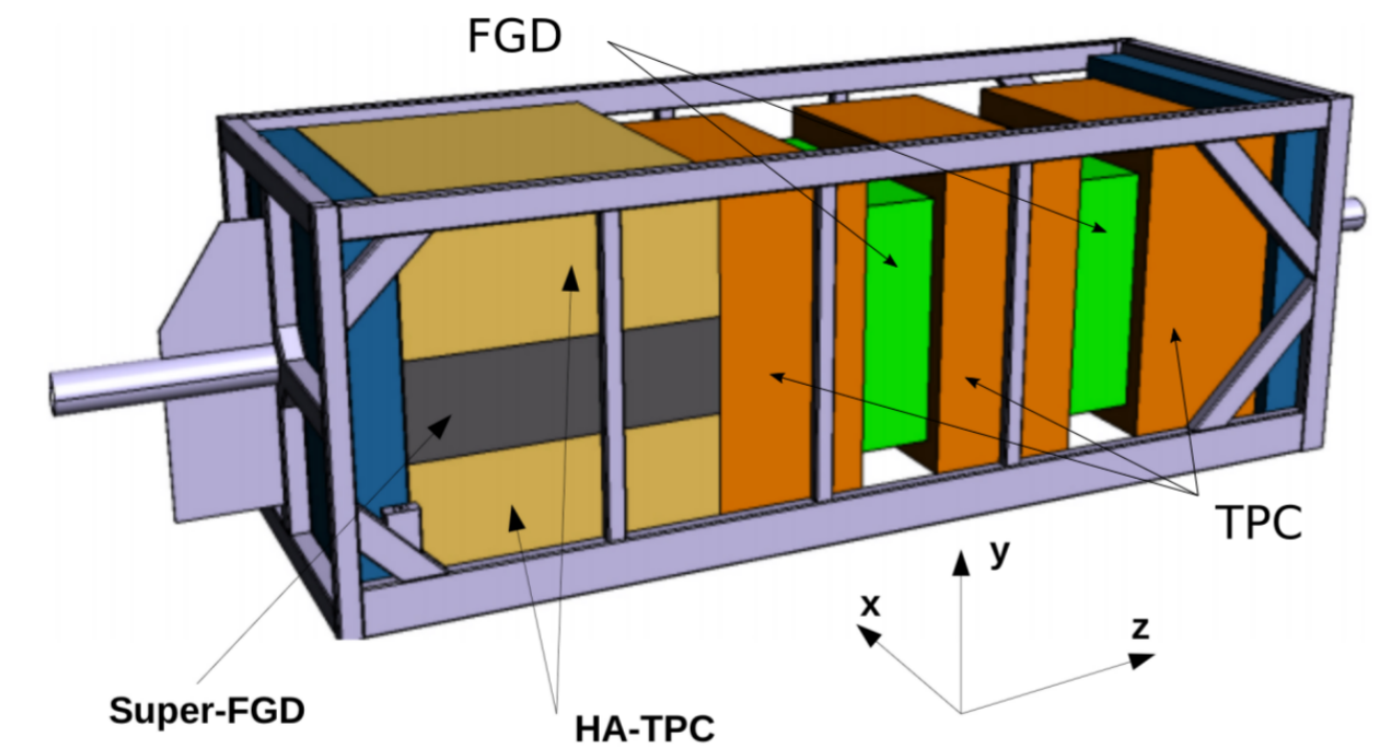
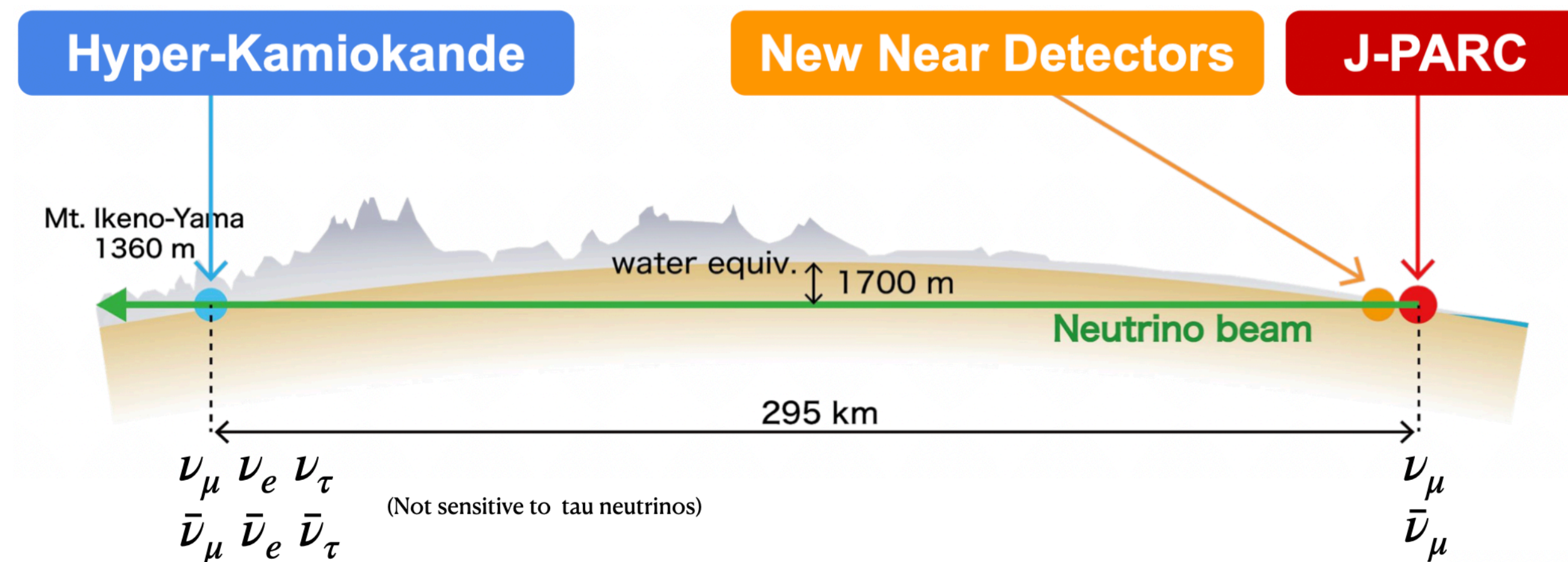

ND280 upgrade: 2.5 deg off-axis angle

Near detectors measure flux and interaction cross-section before oscillation

ND280 upgrade inherited from T2K (280m from target)

Intermediate Water Cherenkov Detector (in construction, 850 m from target)

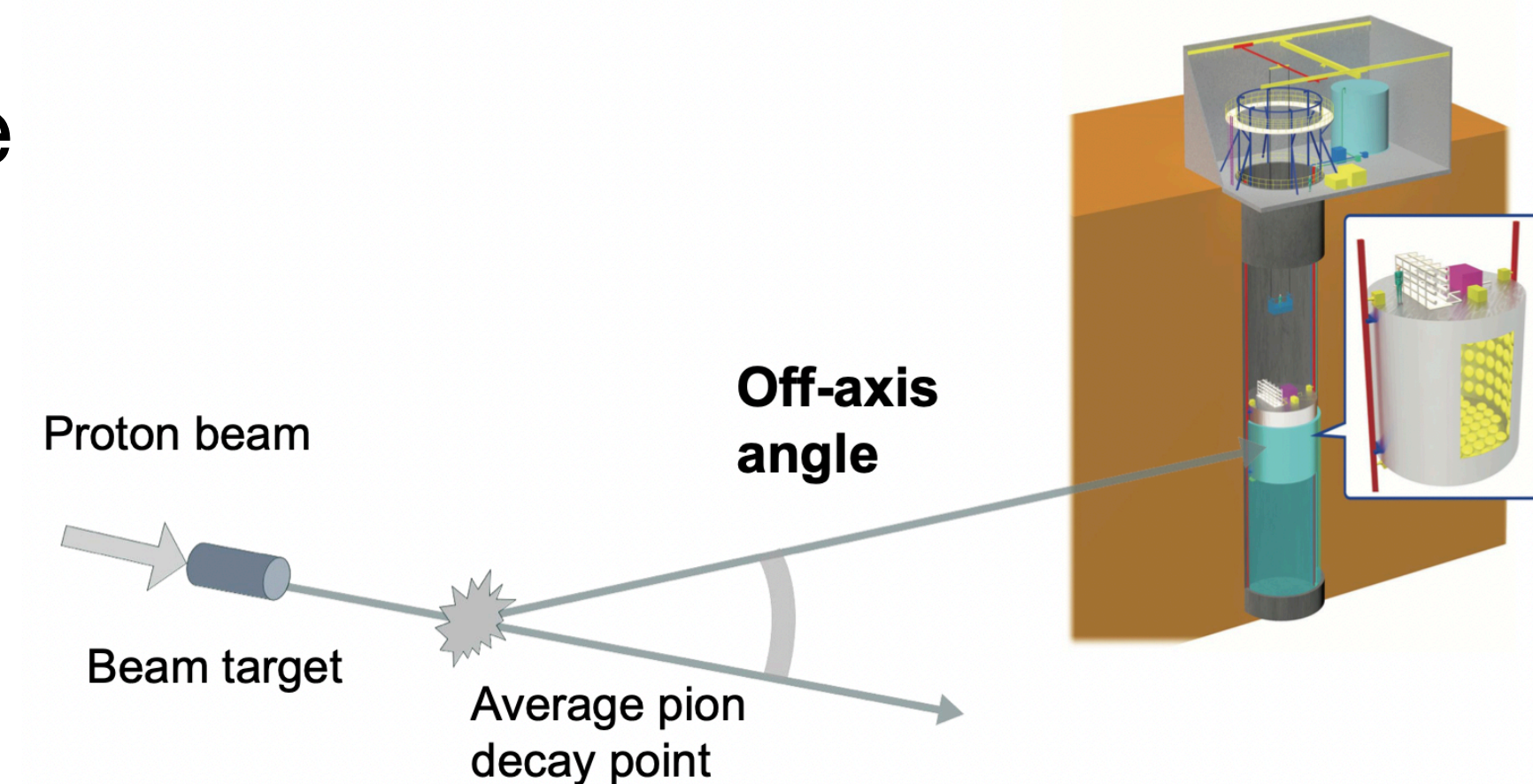

IWCD: vertically movable (varying off-axis angle)

Long baseline program

Physics goal

By **comparing** the **Near and Far** detector measurements, we study

- Muon flavour disappearance: sensitivity to θ_{23} and $|\Delta m_{32}^2|$
- **Electron flavour appearance**

$$P(\bar{\nu}_\mu \rightarrow \bar{\nu}_e) - P(\nu_\mu \rightarrow \nu_e) =$$

$$16 \cos^2 \theta_{13} \cos \theta_{12} \cos \theta_{23} \sin \theta_{12} \sin \theta_{13} \sin \theta_{23} \boxed{\sin \delta_{CP}} \cdot \sin \left(\frac{\Delta m_{32}^2 L}{4E_\nu} \right) \cdot \sin \left(\frac{\Delta m_{31}^2 L}{4E_\nu} \right) \cdot \sin \left(\frac{\Delta m_{21}^2 L}{4E_\nu} \right)$$

This is for oscillation in vacuum, need to add matter effects...



Nature 580 (2020) 7803

T2K excluded CP symmetry at 2σ with $\delta_{CP} \approx -90^\circ$: result limited by statistics

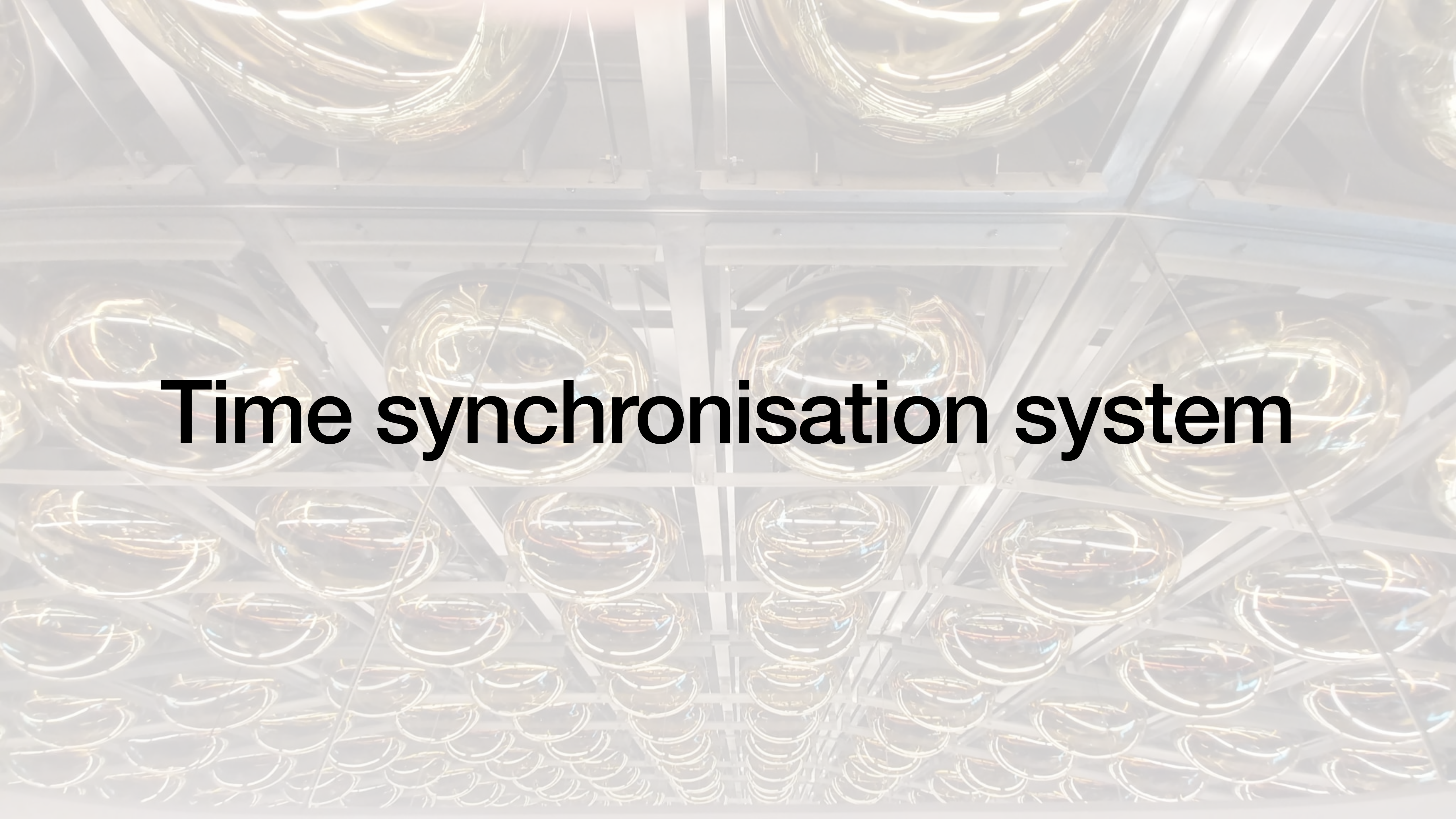

Time synchronisation system

Time synchronisation system

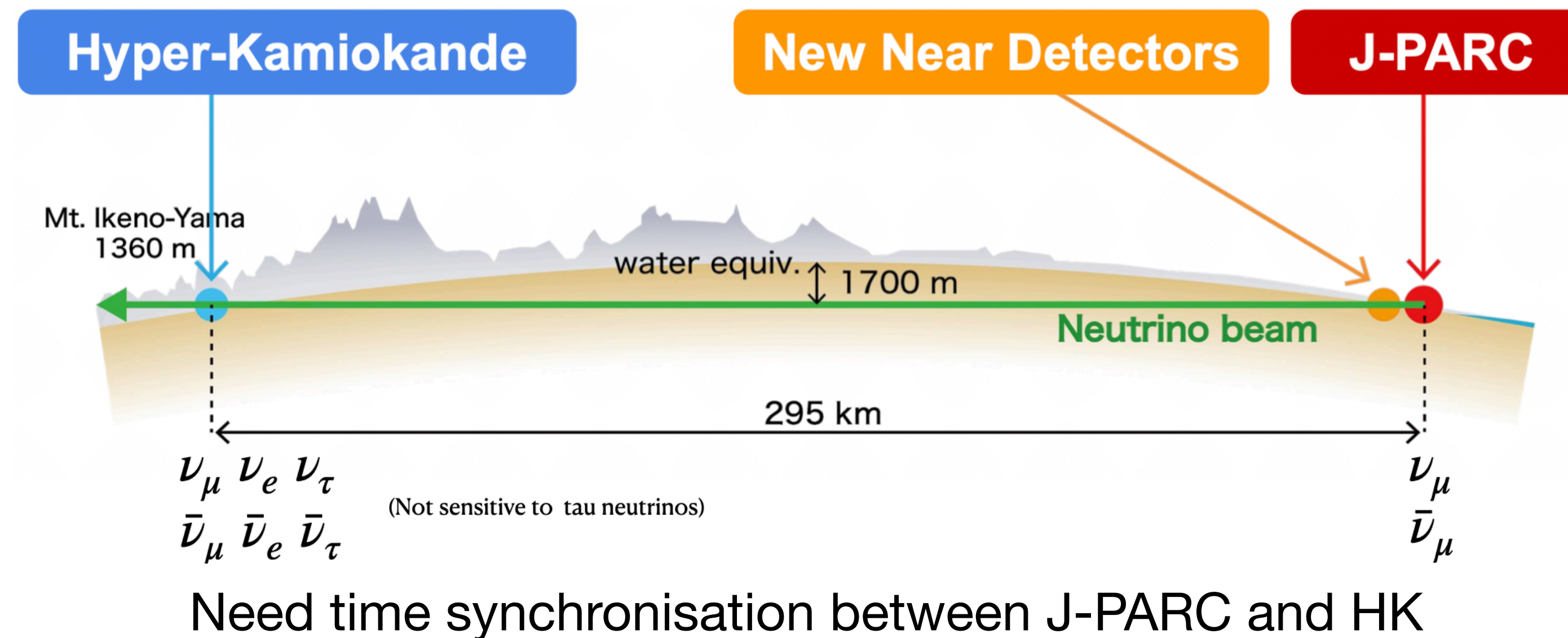

- **Real Time Synchronisation** at **100 ns** level to **Universal Time Coordinated (UTC)** required
- I was responsible for
 - **testing and validating** a synchronisation method
 - the **first implementation** it in real-time

Time synchronisation system

- Time signal generated by an **atomic clock**
- **Antenna and receiver** used to continuously measures difference with respect to **GNSS* Time**
- Measured difference used to **correct local time**



Outside hut

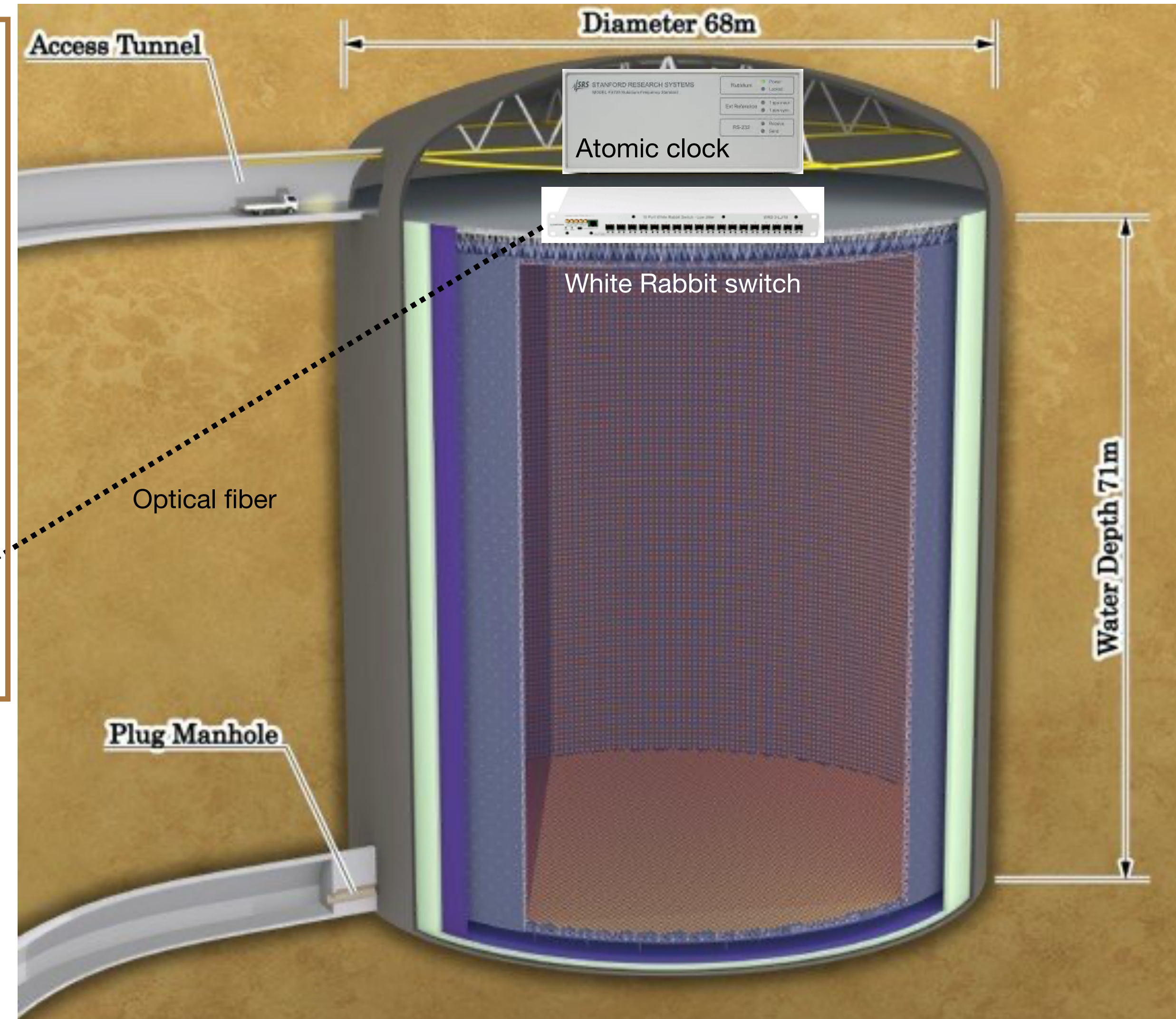

* GNSS: Global Navigation Satellite Systems

Time synchronisation system



- **Fit the local - GNSS Time** measured by GNSS receiver with **piece-wise polynomial functions of time**
- Beware: the **length of the pieces (correction time window)** should be **short enough** so the approximation holds!
- **Extrapolate near future drift** with same polynomial function of time
- Use extrapolation to **correct drift**

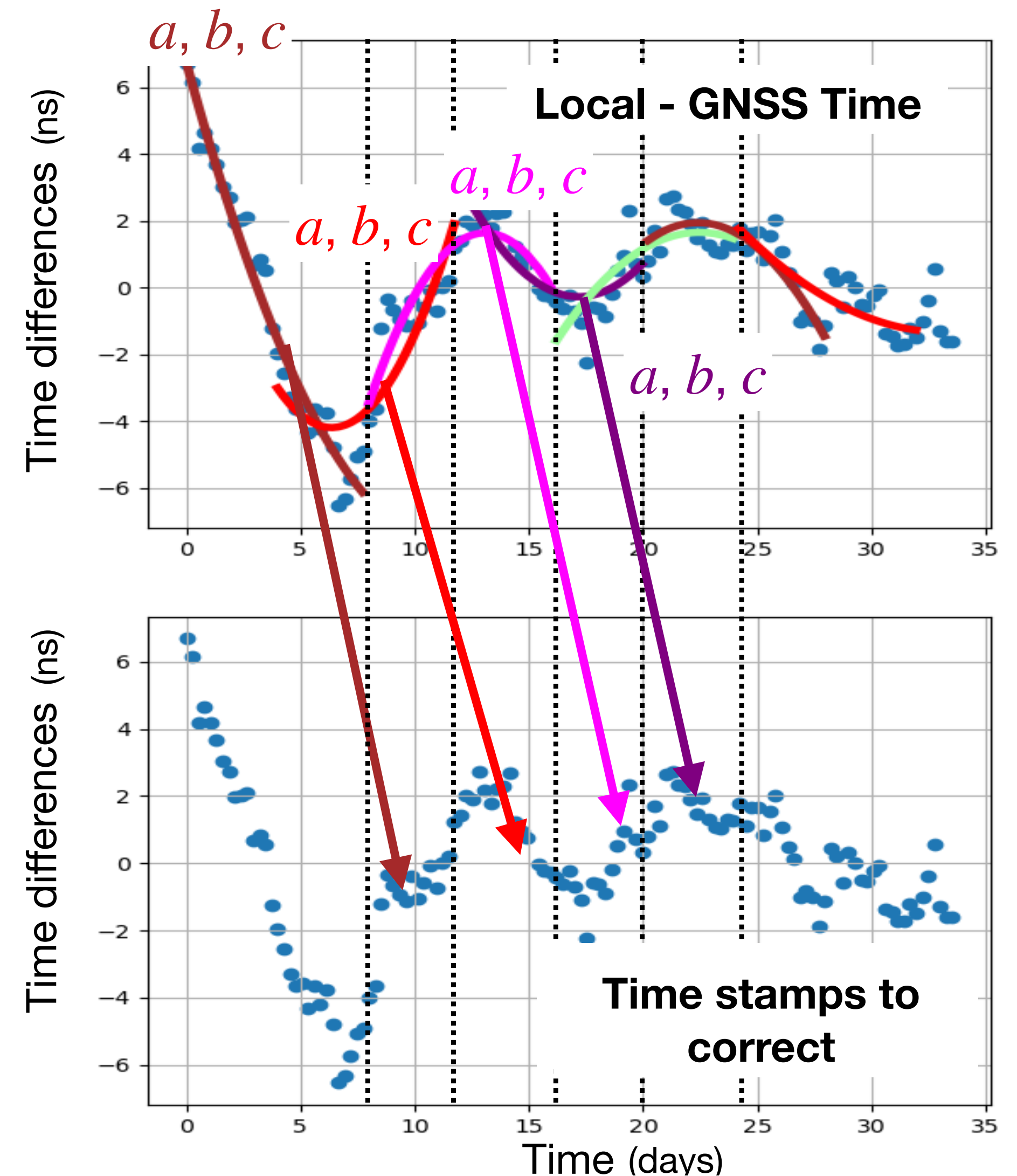

Time synchronisation system

*UTC(OP): French official realisation of UTC made by LTE lab (3km from LPNHE)

- Simultaneous Local - GNSS Time and Local - UTC(OP) measurement
- Use Local - GNSS Time to extract correction
- Apply correction to Local - UTC(OP) measurement
- Check residual differences

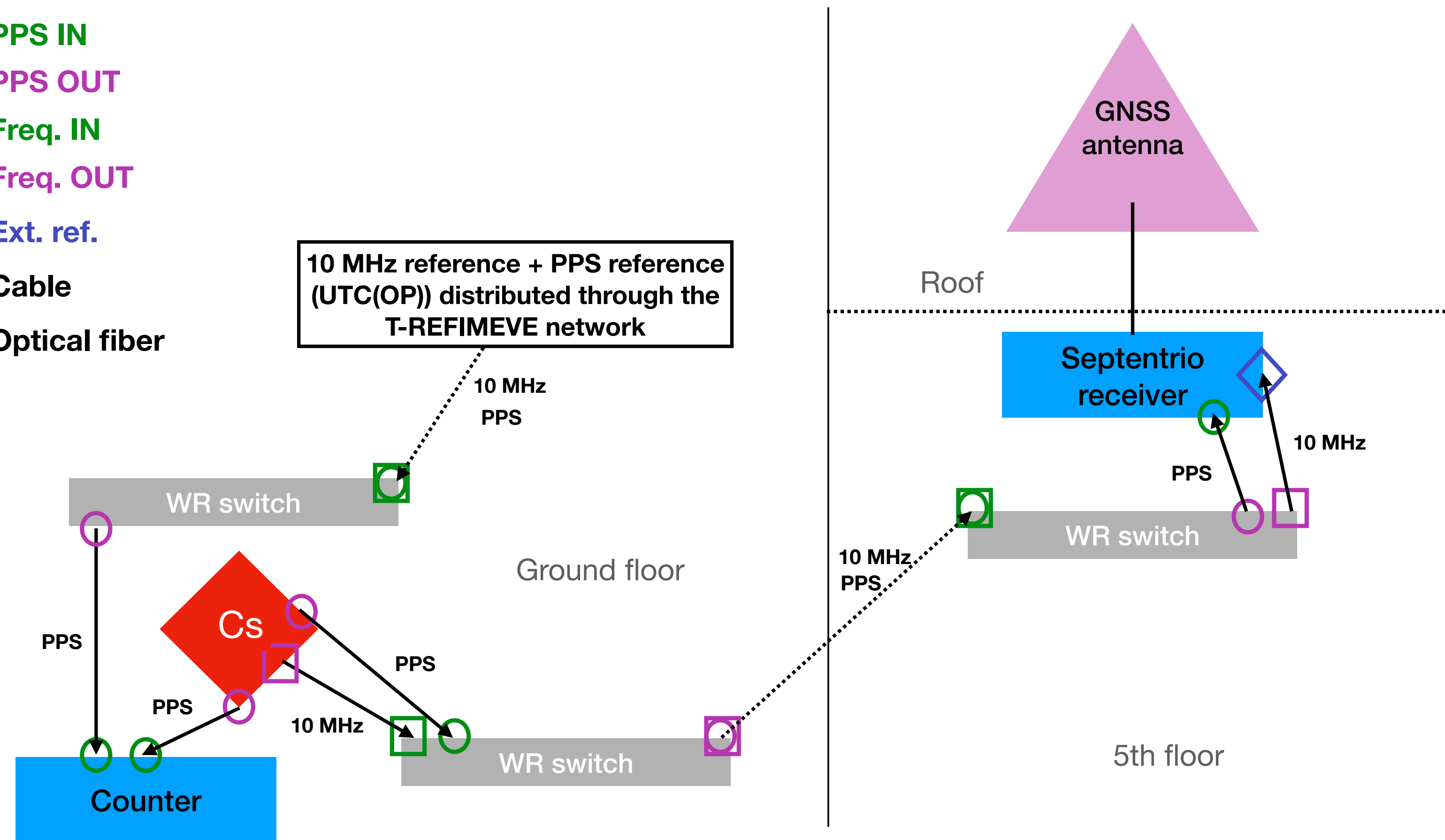
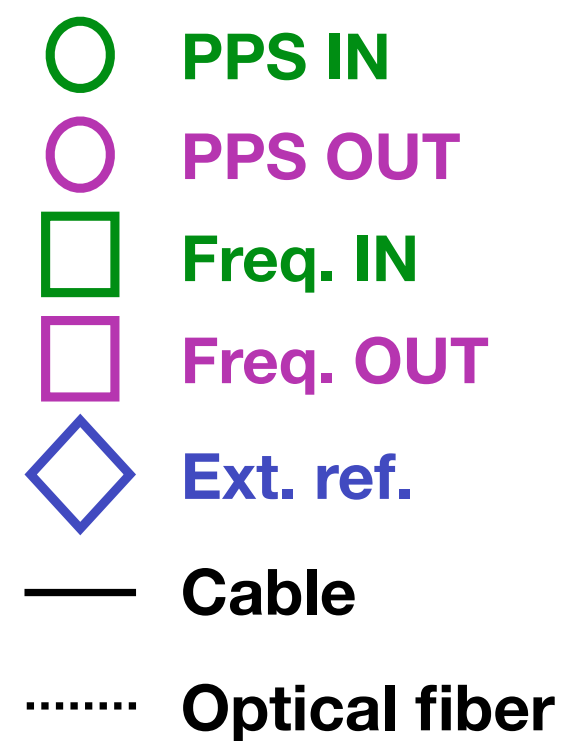

Time synchronisation system

- Apply **correction in real-time** using python scripts executed by the **MIDAS DAQ software**
- **In free-running, Cs clock drift ~ linearly with respect to UTC**
- Real-time correction was **tested on two clocks:**
 - ▶ **Rb:** correction time window of **10 points** (see backup)
 - ▶ **Cs:** correction time window of **100 points**

Clock chosen for HK

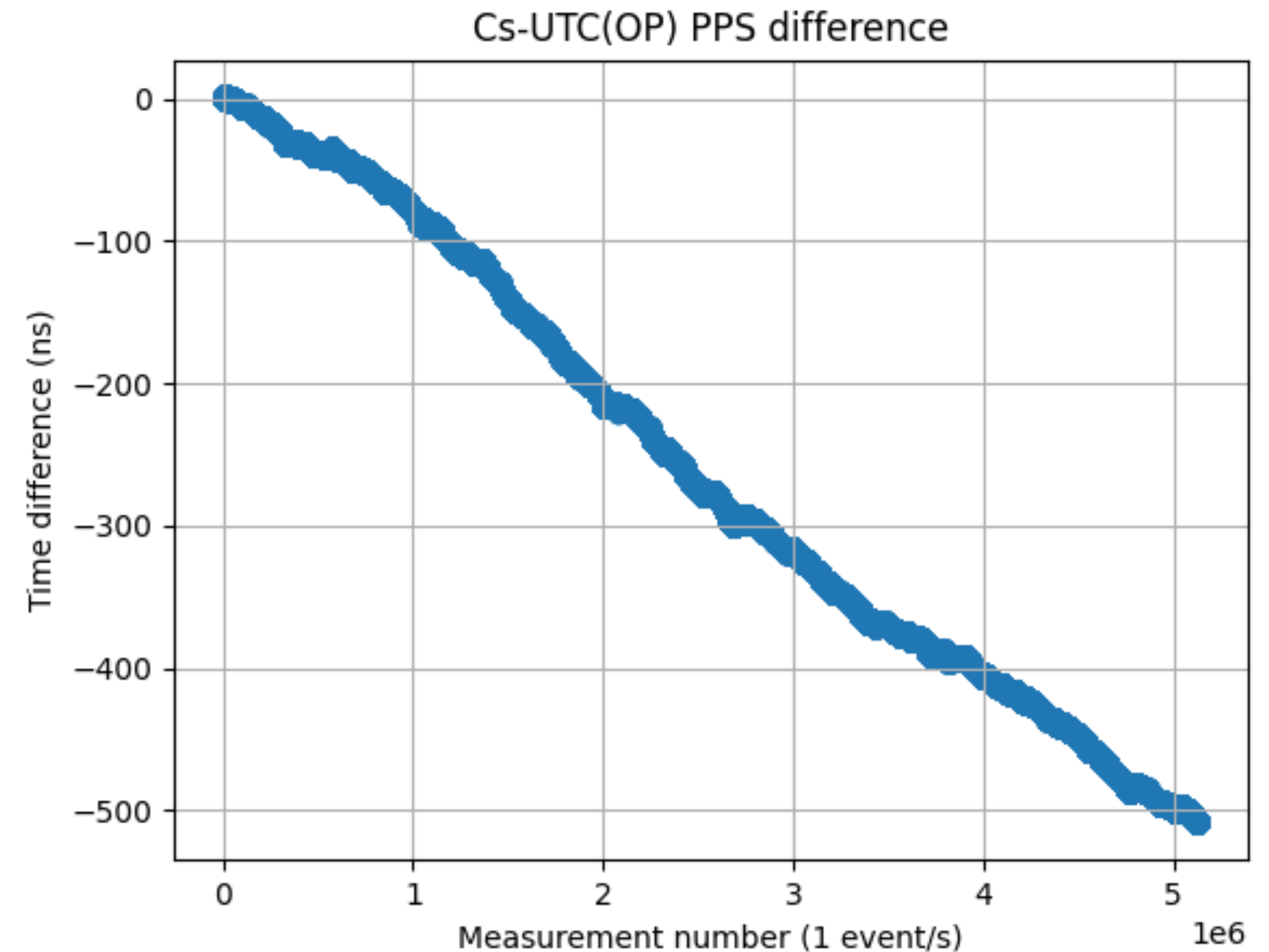

Linear drift typical of frequency mis-calibration.

Continuous monitoring of drift is still needed in case of ageing.

Time synchronisation system

- Real-time correction validated with residuals in 15 ns for both clocks
- For more details see:
 - ▶ **Optimisation, validation in post-processing:** [NIM A 1075 \(2025\) 170358](#)
 - ▶ **Real-time correction:** [\(NIM A 1088 \(2026\) 171471\)](#)
- See Romain Gaior's presentation for more details on the Time distribution systems

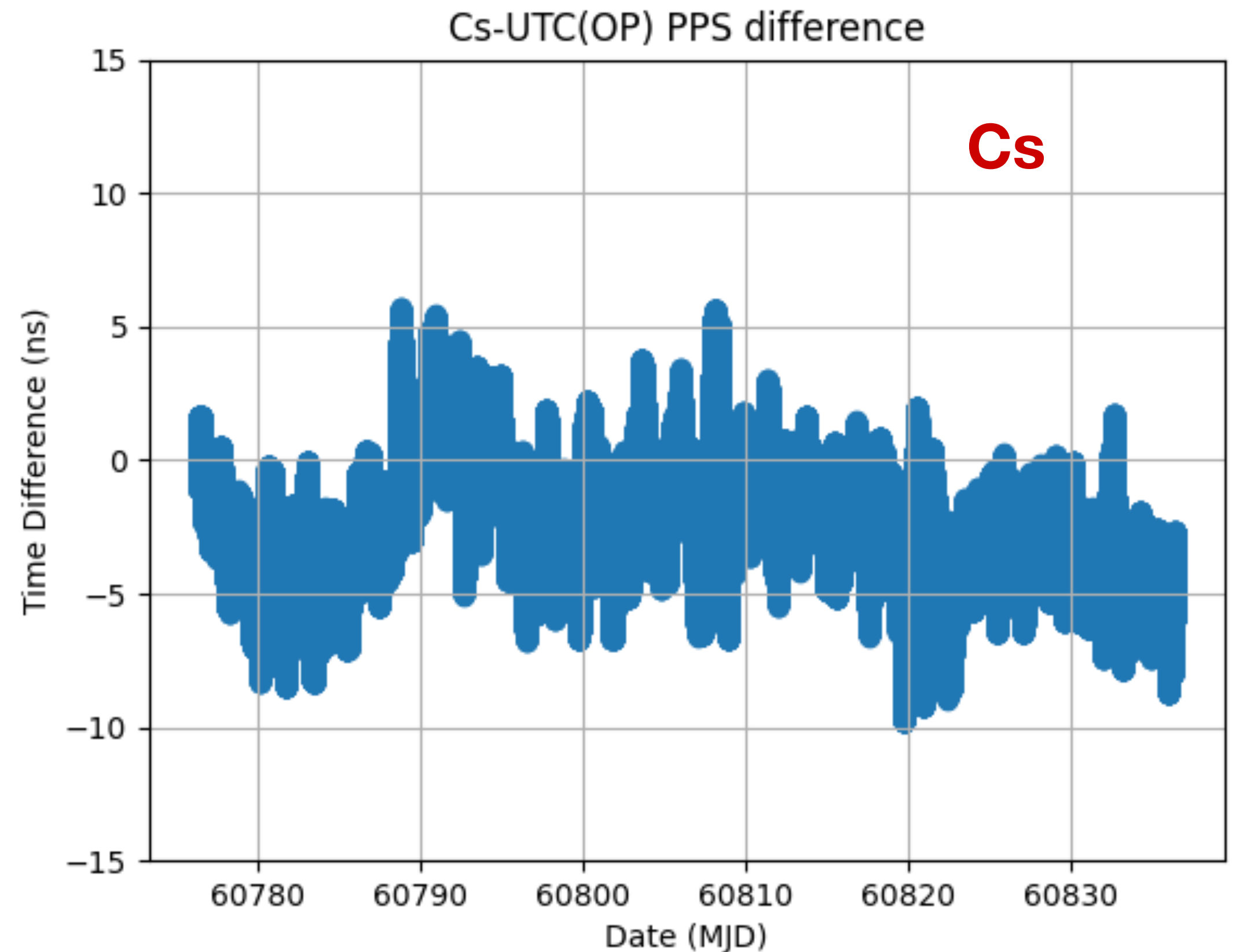

Correction using last 100 measurements



HK's Sensitivity to neutrino oscillation parameters

HK sensitivity

- Fit **simulated data** at the far detector
- Use **recent T2K ND280 constraints of systematic uncertainties**
- Obtain constraints on oscillation parameters
- Today focus on **CP violation**

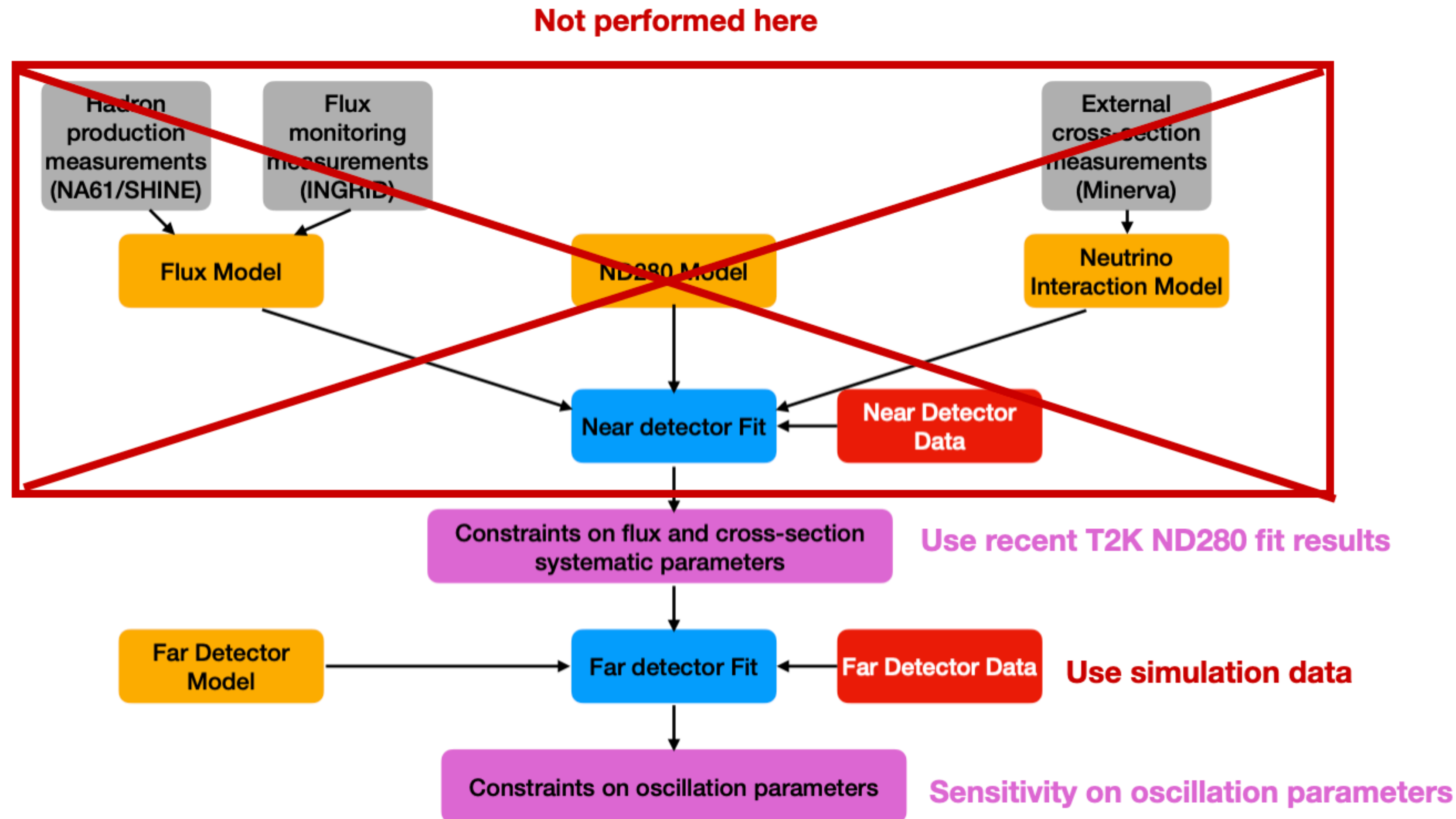

I was responsible for:

- **Adapting** the Far detector **fitter framework** for HK
- Performing **sensitivity studies** for HK

HK sensitivity

Systematics models



Different level of systematic uncertainties:

- Statistics only: only statistical uncertainties
- T2K 2020: same level as in Eur. Phys. J. C (2023) **83**: 782
- **HK Improved error models** built from **T2K 2020** one by **shrinking the uncertainties** to take into better measurements at Near detectors:
 - ▶ **More statistics**: uncertainty on flux and cross section systematics $\propto 1/\sqrt{N}$
 - ▶ **Upgrades**: ND280 upgrade + IWCD

HK sensitivity

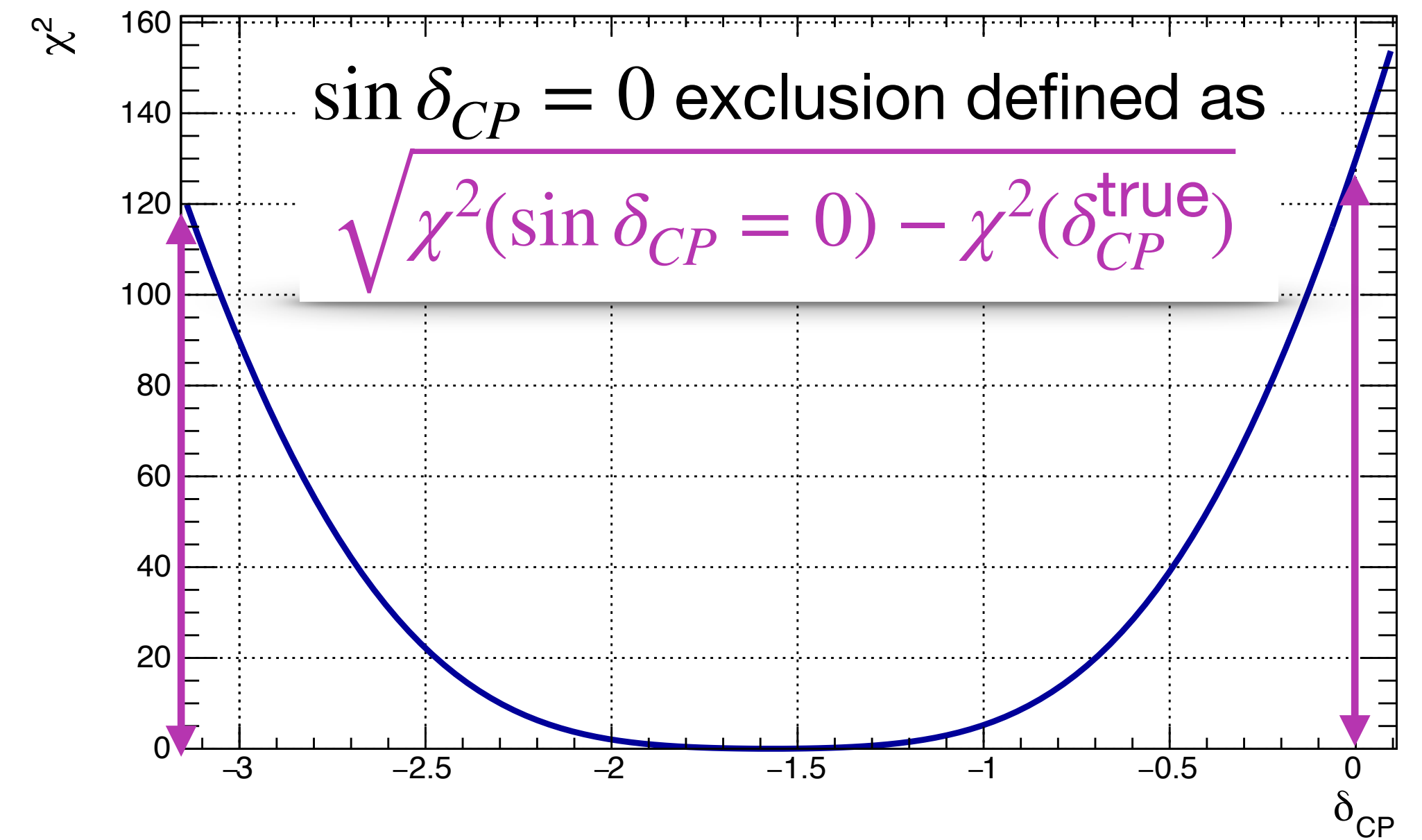
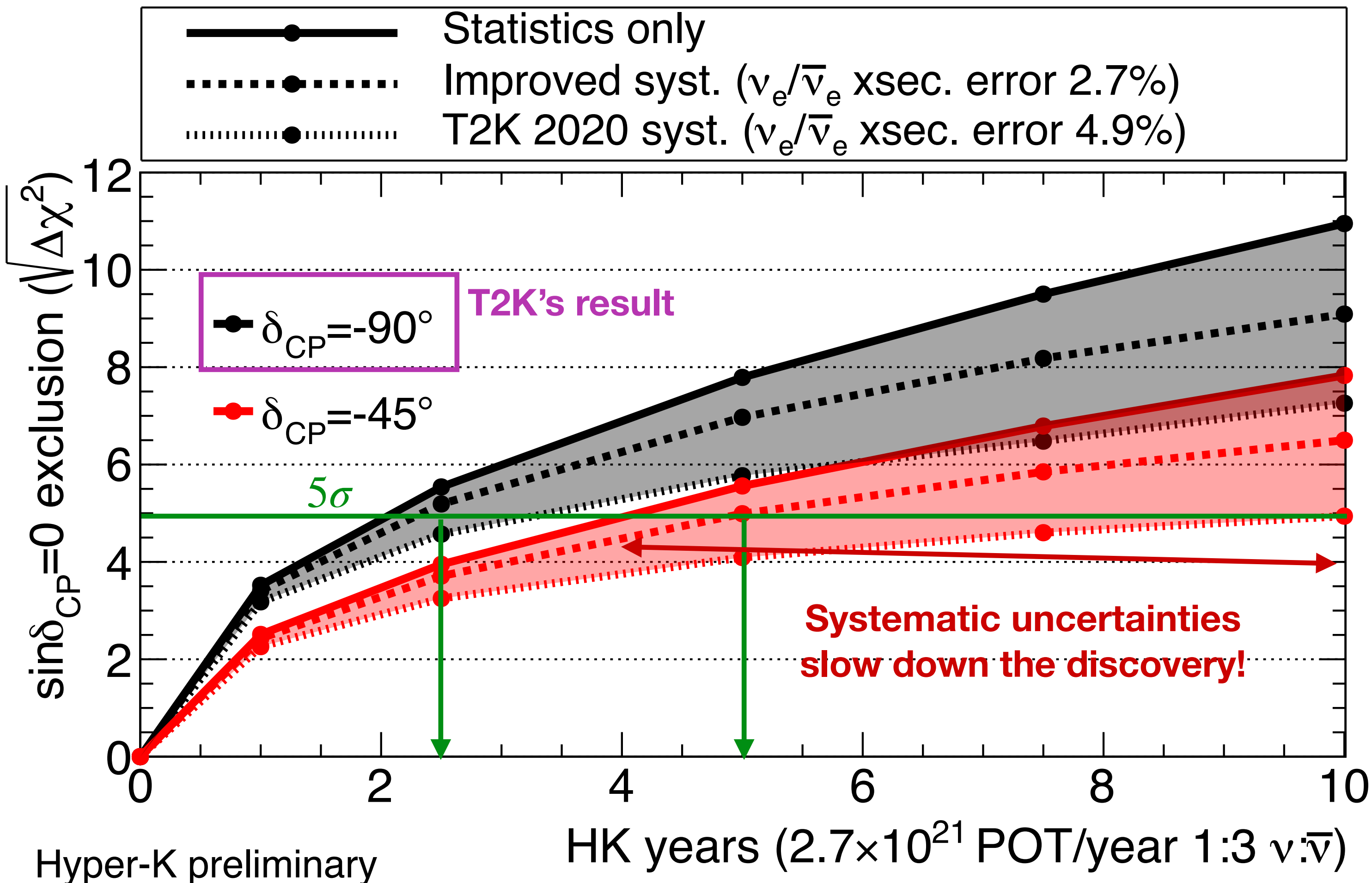

- Only **2-3.5 years** of data necessary for the **5σ discovery** if $\delta_{CP} = -90^\circ$
- **Between 4 and 10 years** of data needed if $\delta_{CP} = -45^\circ$ depending on **systematic uncertainties!**

Hyper-K preliminary

HK sensitivity Degeneracy with MO

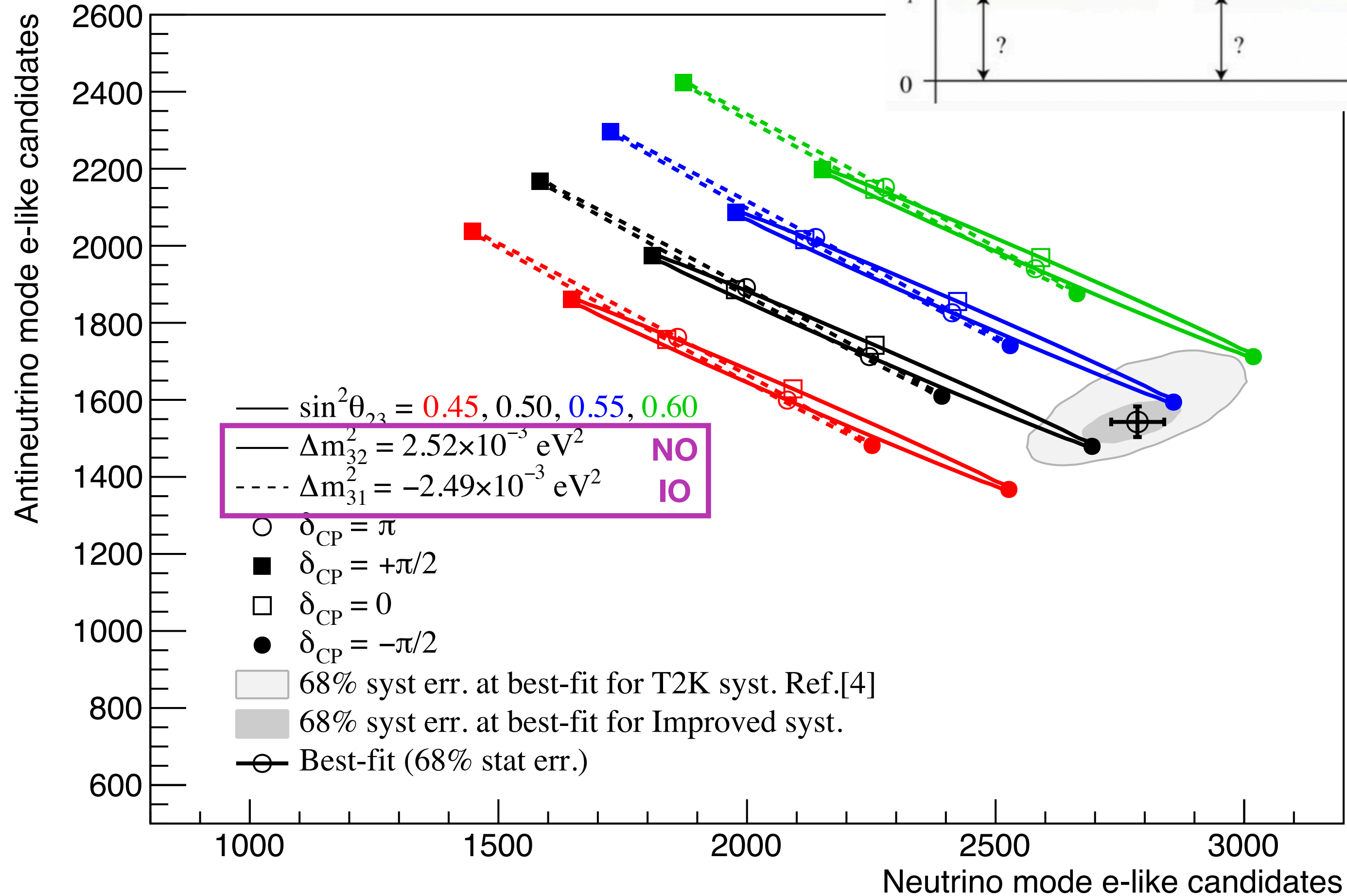
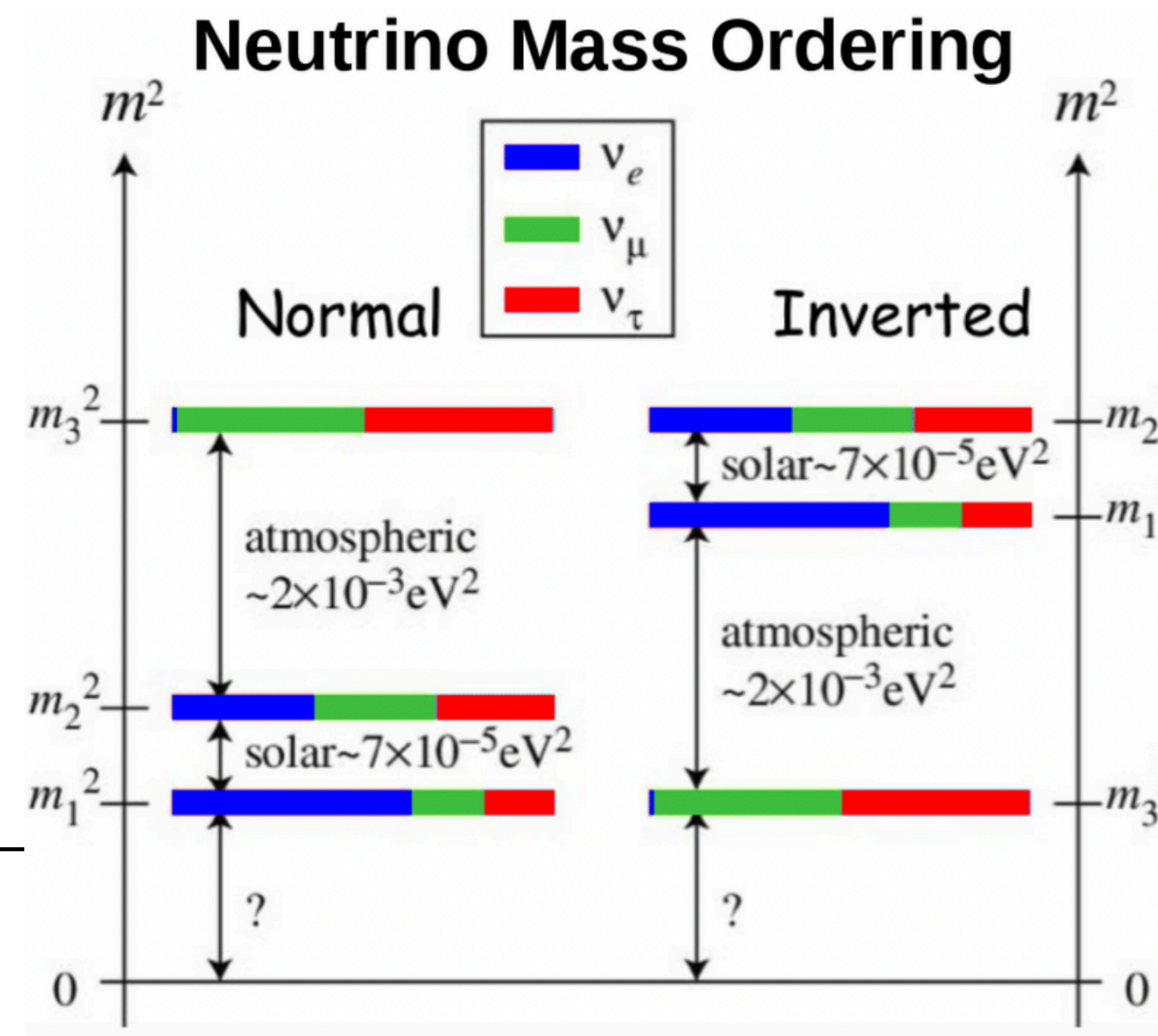

- In previous slides, considered Mass Ordering (MO) known and Normal
- But there is a **degeneracy between δ_{CP} and MO** in beam samples
- If MO is not known, it would **reduce sensitivity to CP violation in the degenerate regions**
- Can add **atmospheric samples** to give **better constraint on MO** (see more in backup)



HK sensitivity

Joint fit sensitivity to CP violation

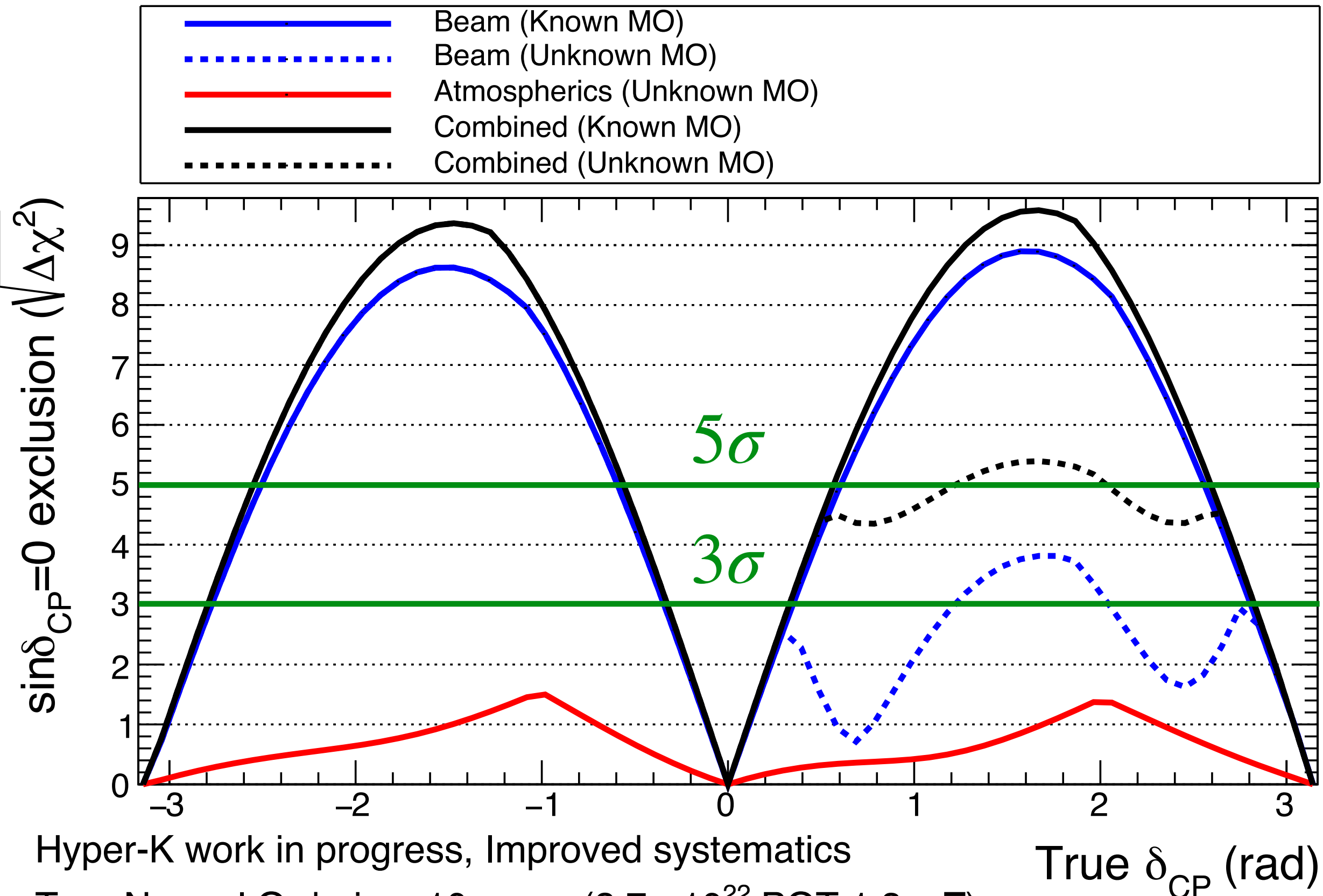

After 10 years exposure, **if MO is unknown**:

- **Beam only:**
 - ▶ **no 5σ exclusion** of CP in the **degenerate region**
 - ▶ diminished 3σ exclusion capabilities
- **Adding atmospheric:**
 - ▶ **same 3σ exclusion** potential in **both regions**
 - ▶ **Increased 5σ exclusion** potential compared to beam-only

Hyper-K work in progress, Improved systematics

True Normal Ordering, 10 years (2.7×10^{22} POT 1:3 $\nu:\bar{\nu}$)

$\sin^2\theta_{13}=0.0218\pm 0.0007$, $\sin^2\theta_{23}=0.528$, $\Delta m_{32}^2=2.509 \times 10^{-3} \text{eV}^2/c^4$

HK sensitivity

Conclusions

- **First iteration of sensitivity studies with the p-theta fitter** (with Dr. Denis Carabadjac, CEA)
 - **Preparation** of fitter framework for data-taking
 - Understanding of the experiment's **potential**
 - Anticipate possible **limitations (e.g., systematics, degeneracies)**
- In this presentation, focus on sensitivity to CP violation
- For more results, see:
 - **[EPJC 86 \(2026\) 170](#)**
 - Backup slides



**Measurement of CP violation in
neutrino flavour oscillations with
Hyper-Kamiokande**



Claire Dalmazzone, EPS-HEP, July 2025, Marseille
On behalf of Hyper-Kamiokande Collaboration



Thank you!



Introduction

T2K results

- Preference for maximal CP violation and Normal Ordering
- Results largely limited by statistics

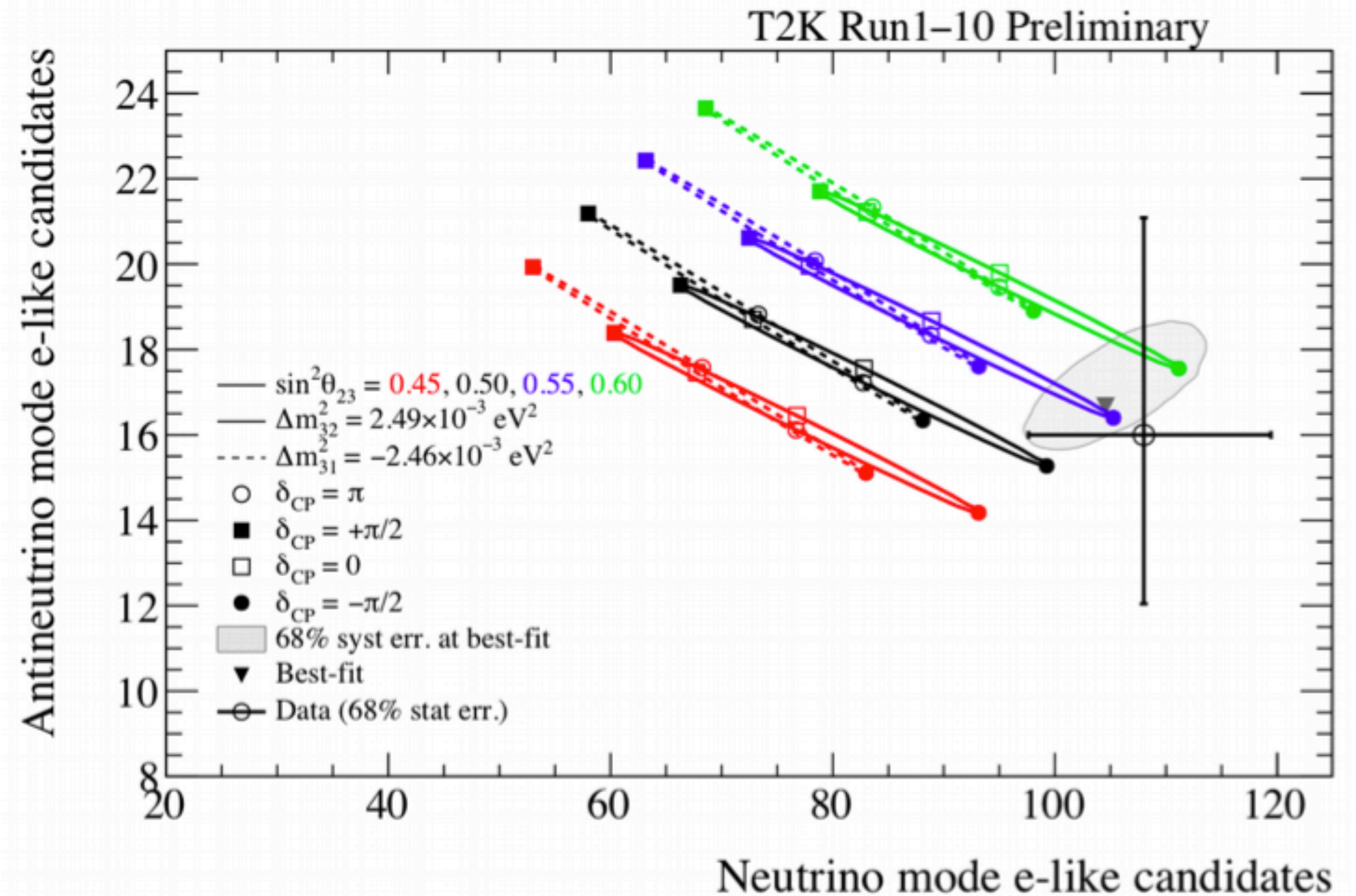

Time synchronisation system

Rubidium clock

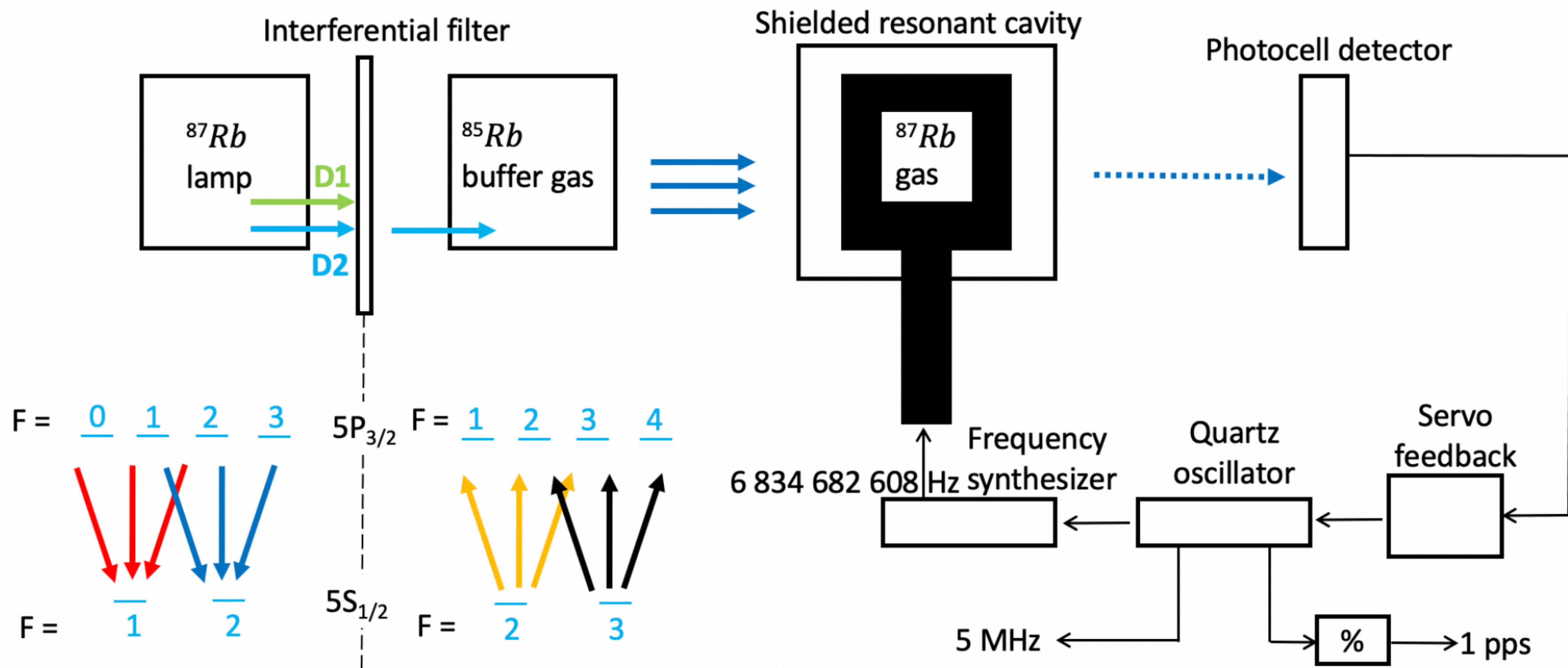

The closer the input frequency the more luminosity expected after the resonant cavity.

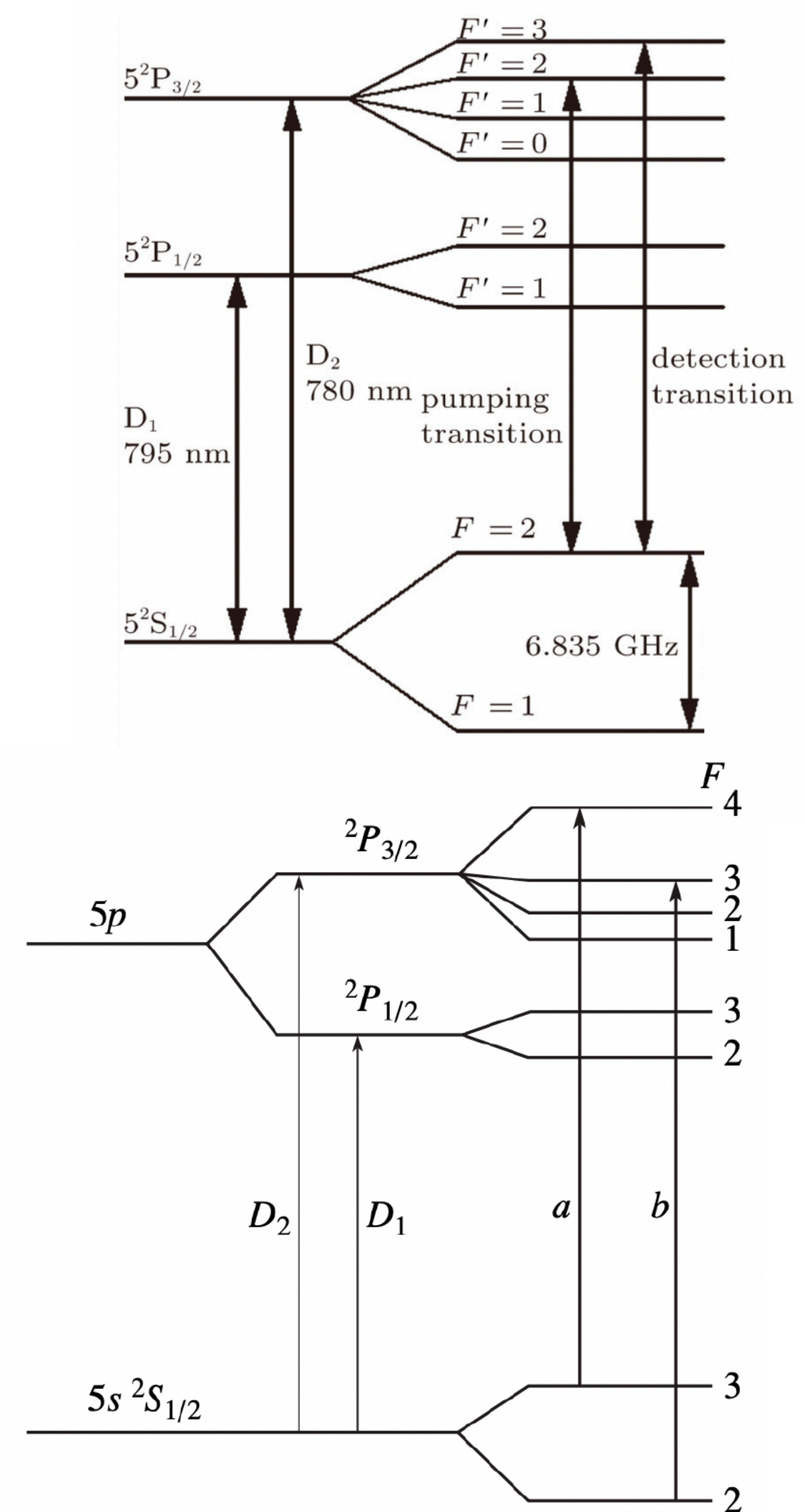

Hyperfine structures of Rb87 and Rb85

Time synchronisation system

Time transfer with GNSS

Time delay $\Delta\tau$ between a **satellite (GNSS Time)** and the **local clock** time bases can be inferred from:

- The **real distance** between the two objects (requires **precise knowledge of the positions**): $\Delta D = c\Delta T$
- The **measured time of signal emission** in satellite time base: t_1^S
- The **measured time of signal reception** in local time base: t_2^r

$$\Delta\tau = t_2^r - t_1^S - \Delta T$$

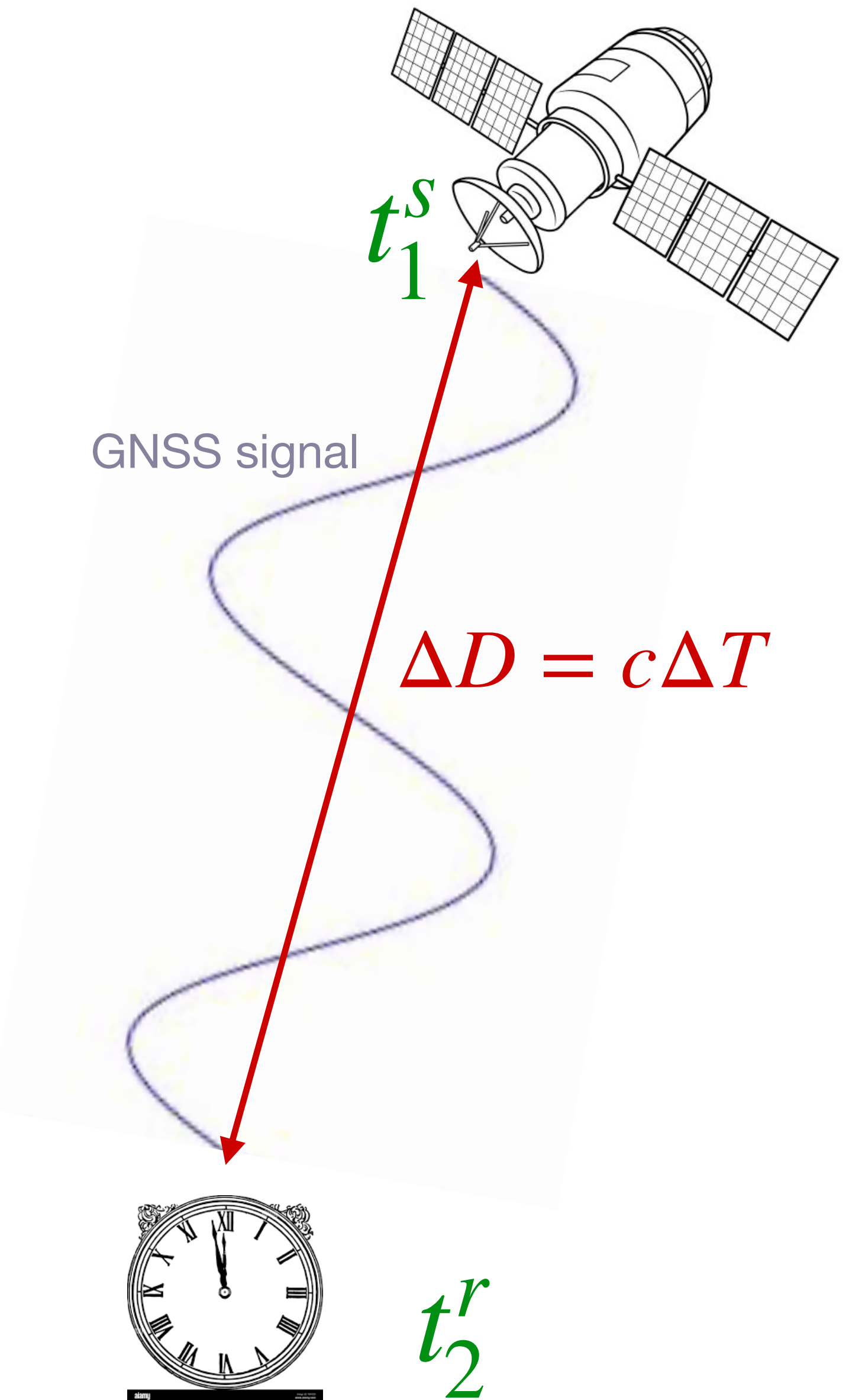

Time synchronisation system

Time transfer with GNSS

In practice, the receiver:

- **Tracks** a satellite i **for 13 minutes**
- **Computes** $\Delta\tau_n^i$ **every 30 seconds**
- **Applies various corrections** (cable delays, atmospheric effects, relativistic effects)
- Performs **linear fits** of $(\Delta\tau_n^i)_n$ series to **extract** $\Delta\tau^i$ at the middle of the 13 minutes range and the **slope of the drift**

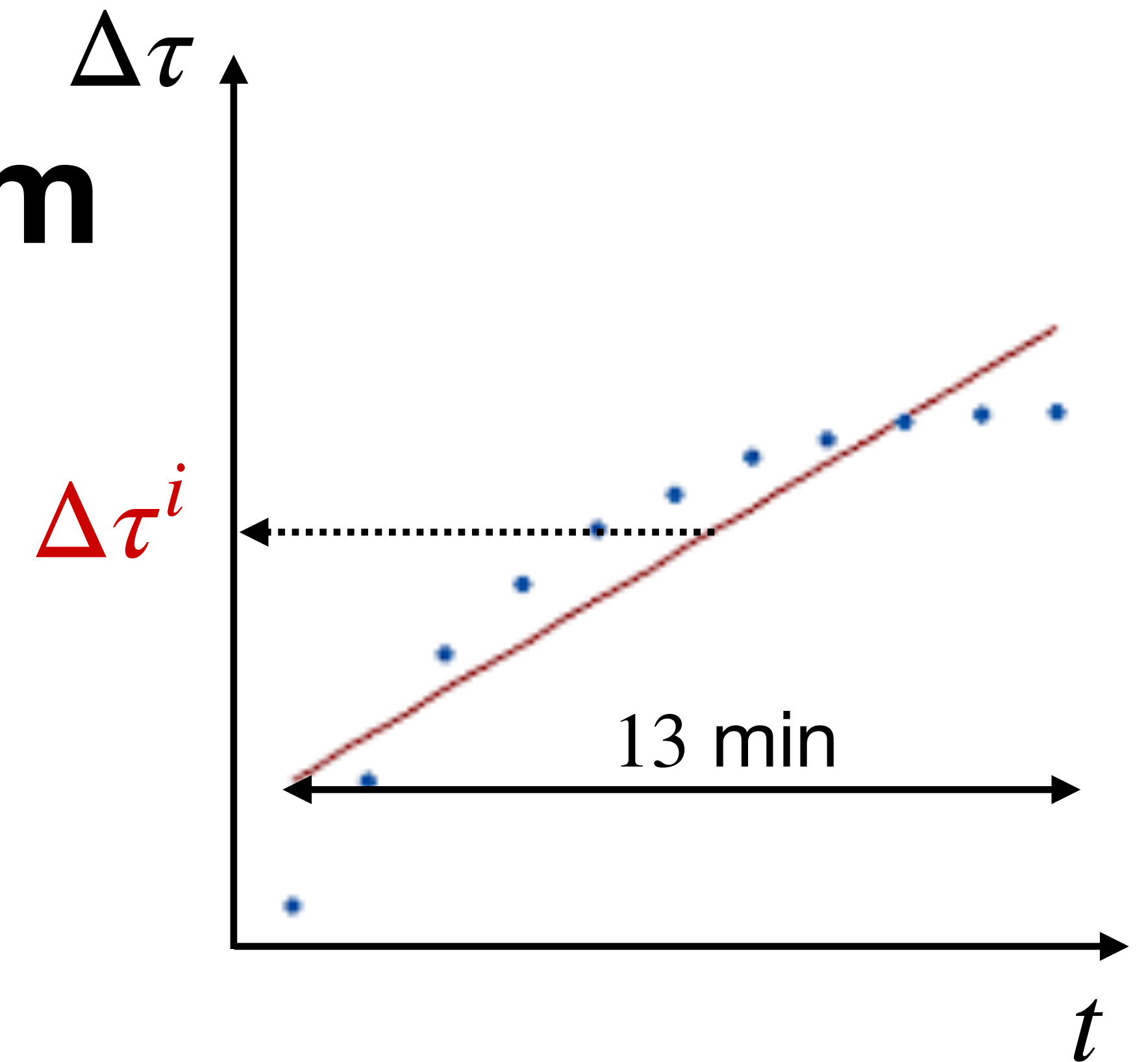

Time synchronisation system

Common view technique

Synchronisation of J-PARC (Clock A) and HK (Clock B) will use the “**common-view**” technique:

- ▶ Use all **satellites that are seen at the same time** by site A and B

Allows **cancellation of common sources of uncertainties** compared to “all in view” technique

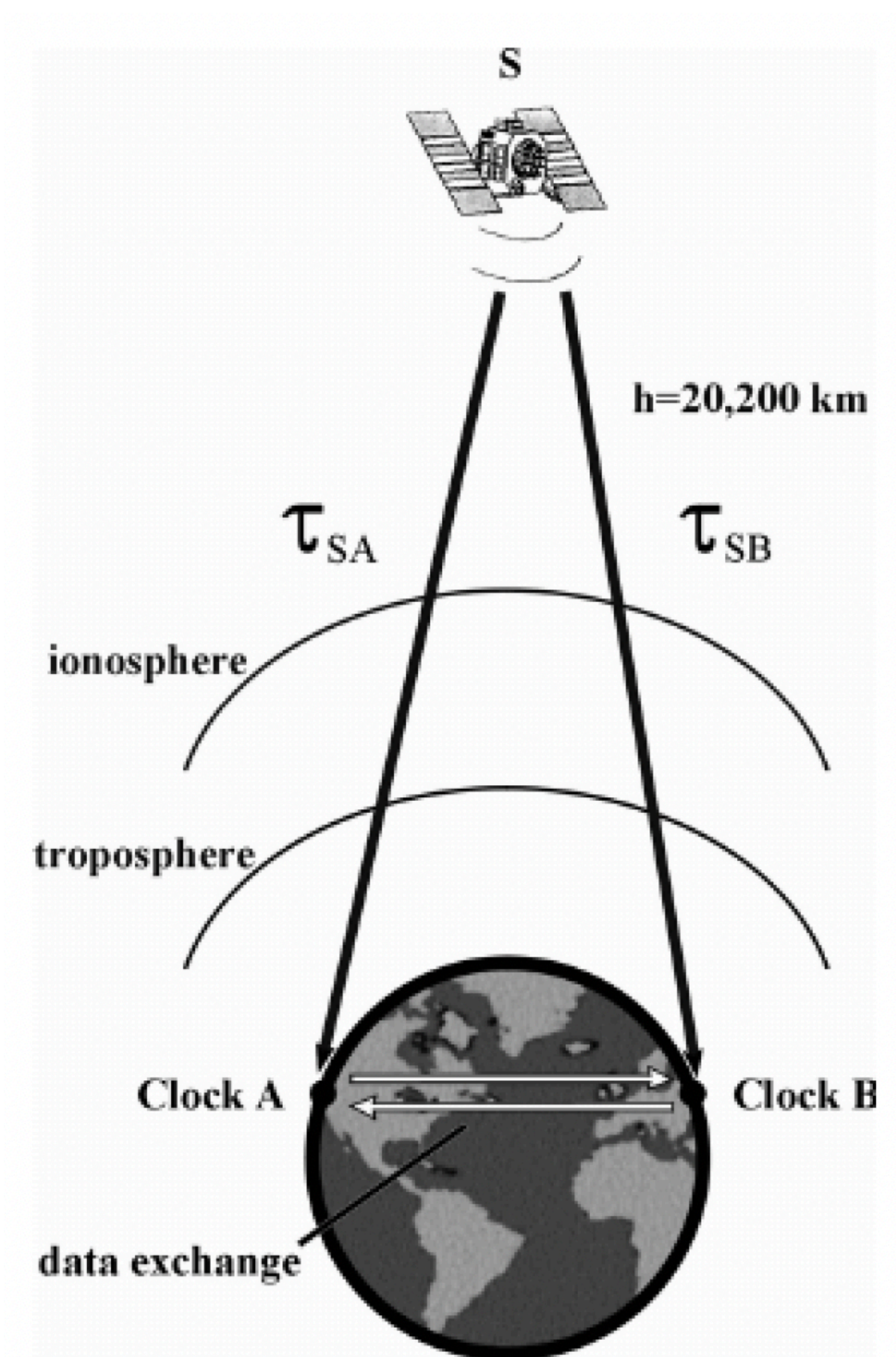

Time synchronisation system



- Fit the local - GNSS Time measured by GNSS receiver with piece-wise polynomial functions of time:

Correction time window

$$\forall t \in [t_k, t_k + \Delta t], t_{\text{clock}} - t_{\text{GNSS}} = a_k \cdot t + b_k$$

- Correct local time signal by subtracting the fit result to the local time base:

$$\forall t \in]t_k + \Delta t, t_k + \Delta t + \delta t], t_{\text{clock,corr}} = t_{\text{clock}} - (a_k \cdot t + b_k)$$

Determines frequency at which we update the correction coefficients: every time we receive a new measurement from receiver (~16 min).

Time synchronisation system

Correction optimisation

- Rubidium clock exhibits **long term quadratic drift** but also **shorter term random walk**
- If the **correction time window is too long**, it will **not properly correct the random walk**
- The correction method needs to be **optimised for this clock**

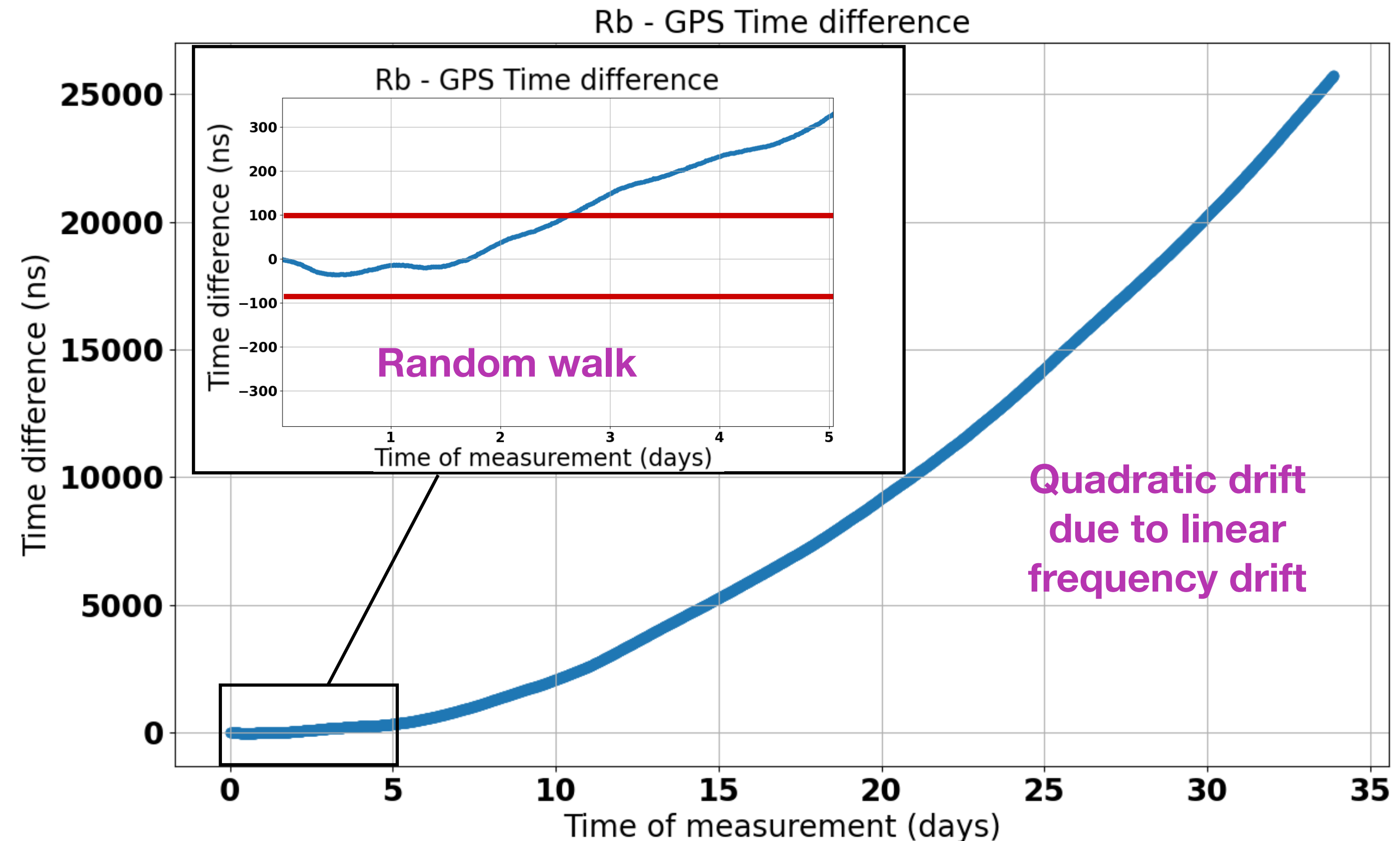

Time synchronisation system

Correction optimisation

Validation in post-processing: NIM A 1075
(June 2025) 170358

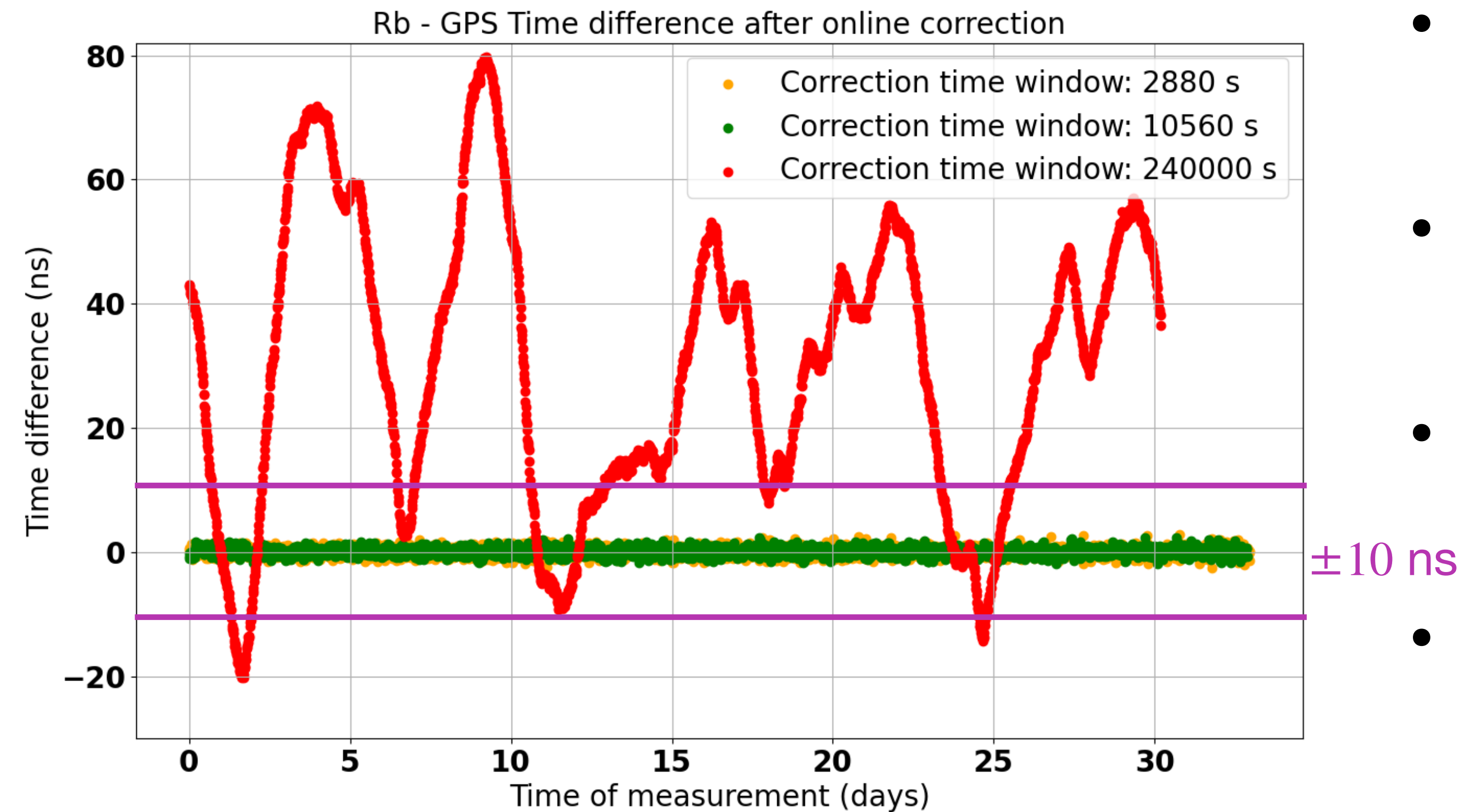

- If the **correction time window** is **too short**, less reliable fit
- **Optimal** is to take the **longest window** that **corrects random walk**
- Obtain **synchronisation to GPS Time** at **<10 ns** level
- This optimisation **specific to** this model of **Rb clock**

For both offline and online method, found **optimal time window** of around 10,000 seconds (**~10 receiver measurements**) for the Rubidium clock

Time synchronisation system

Real-time correction

- Now need to apply **correction in real-time**
- Using **MIDAS DAQ software**
- Real-time correction was **tested on two clocks:**
 - ▶ **Rb:** correction time window of **10 points**
 - ▶ **Cs:** correction time window of **100 points**

Real-time correction results: NIM A 1088
(August 2026) 171471

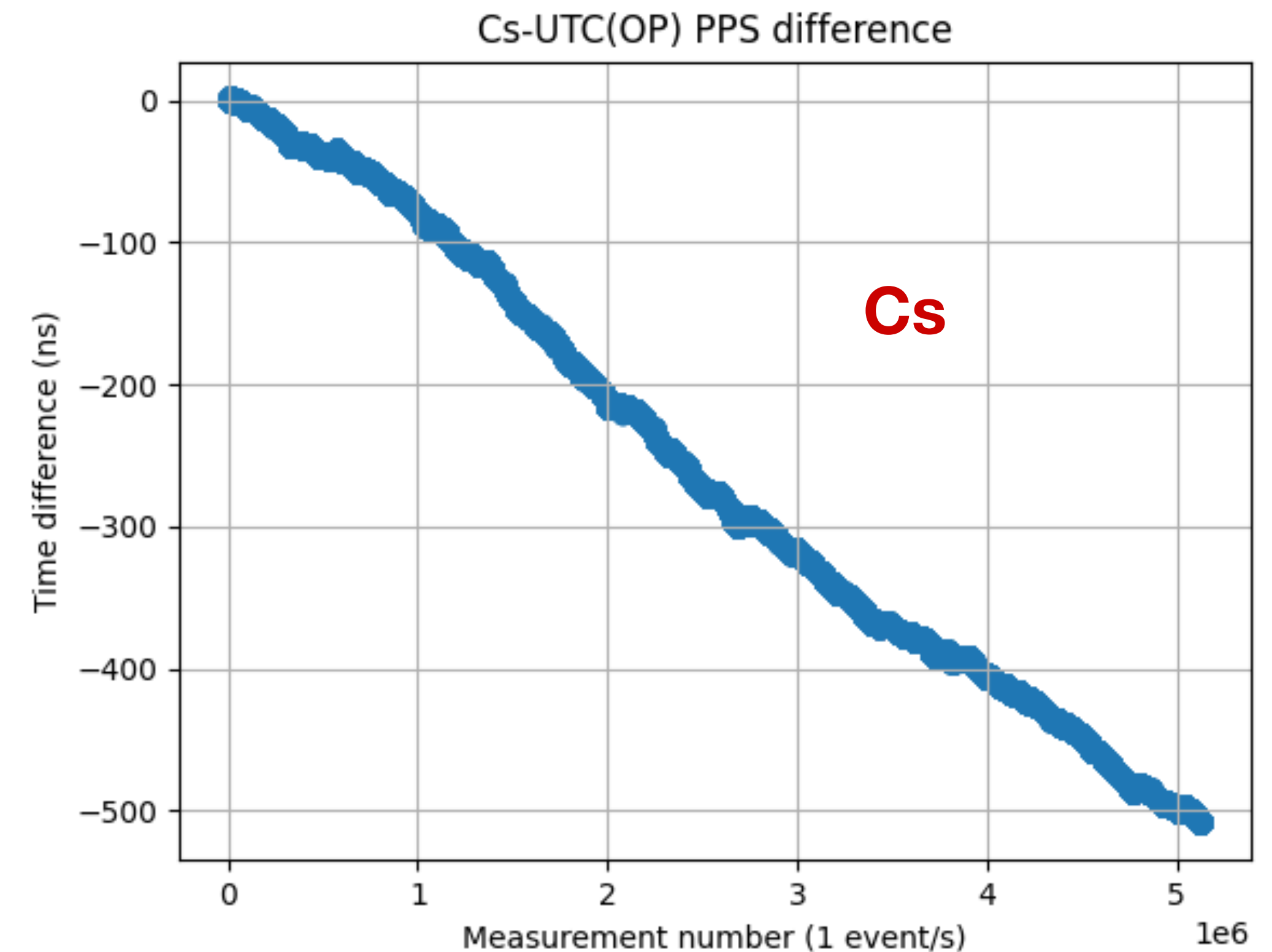

Cs clock PPS drifts much slower compared to Rb: **linear drift typical of frequency mis-calibration.**

Continuous monitoring of drift is still needed in case of ageing.

Time synchronisation system

Real-time correction

Real-time correction results: NIM A 1088
(August 2026) 171471

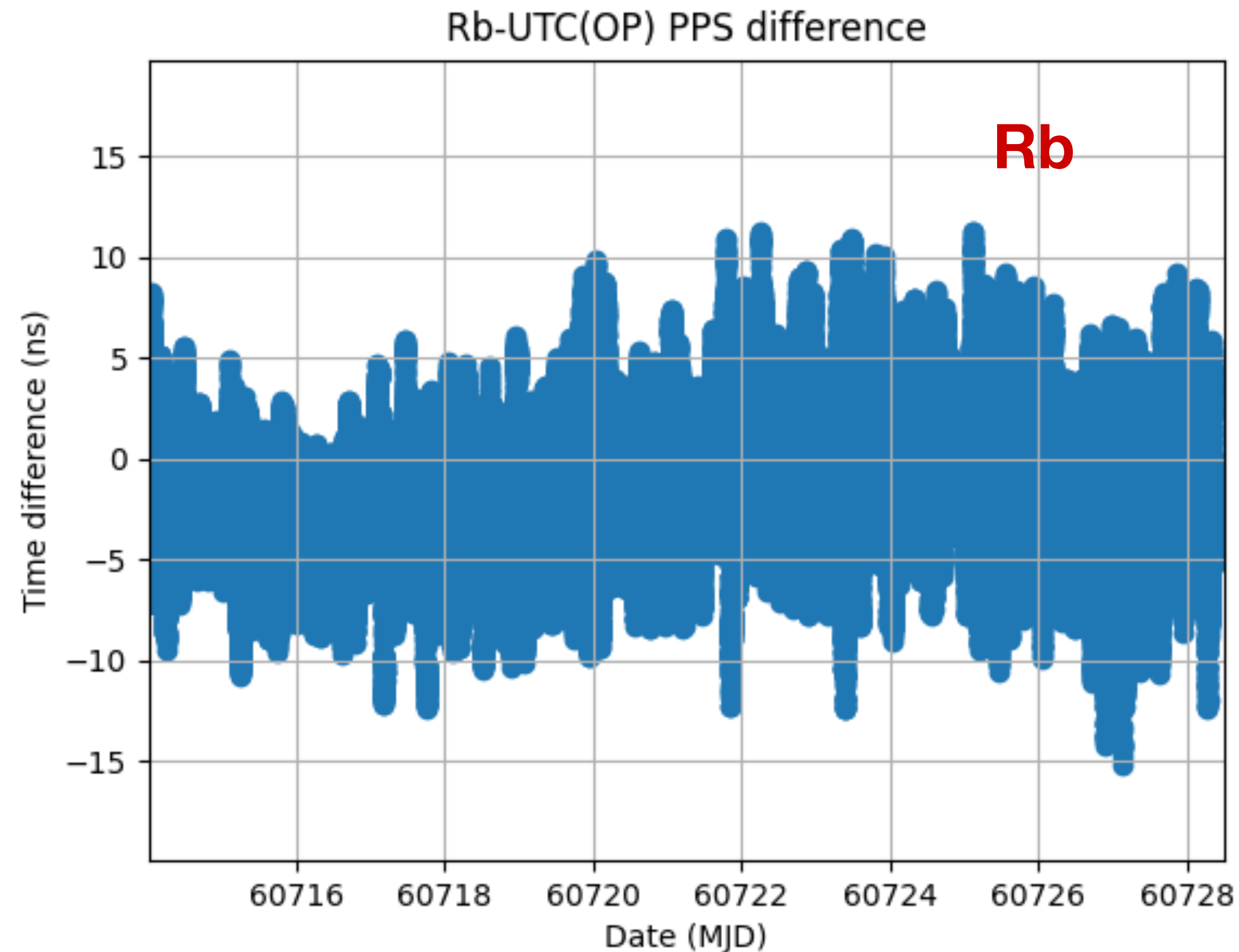

Correction using 10 last GNSS measurements

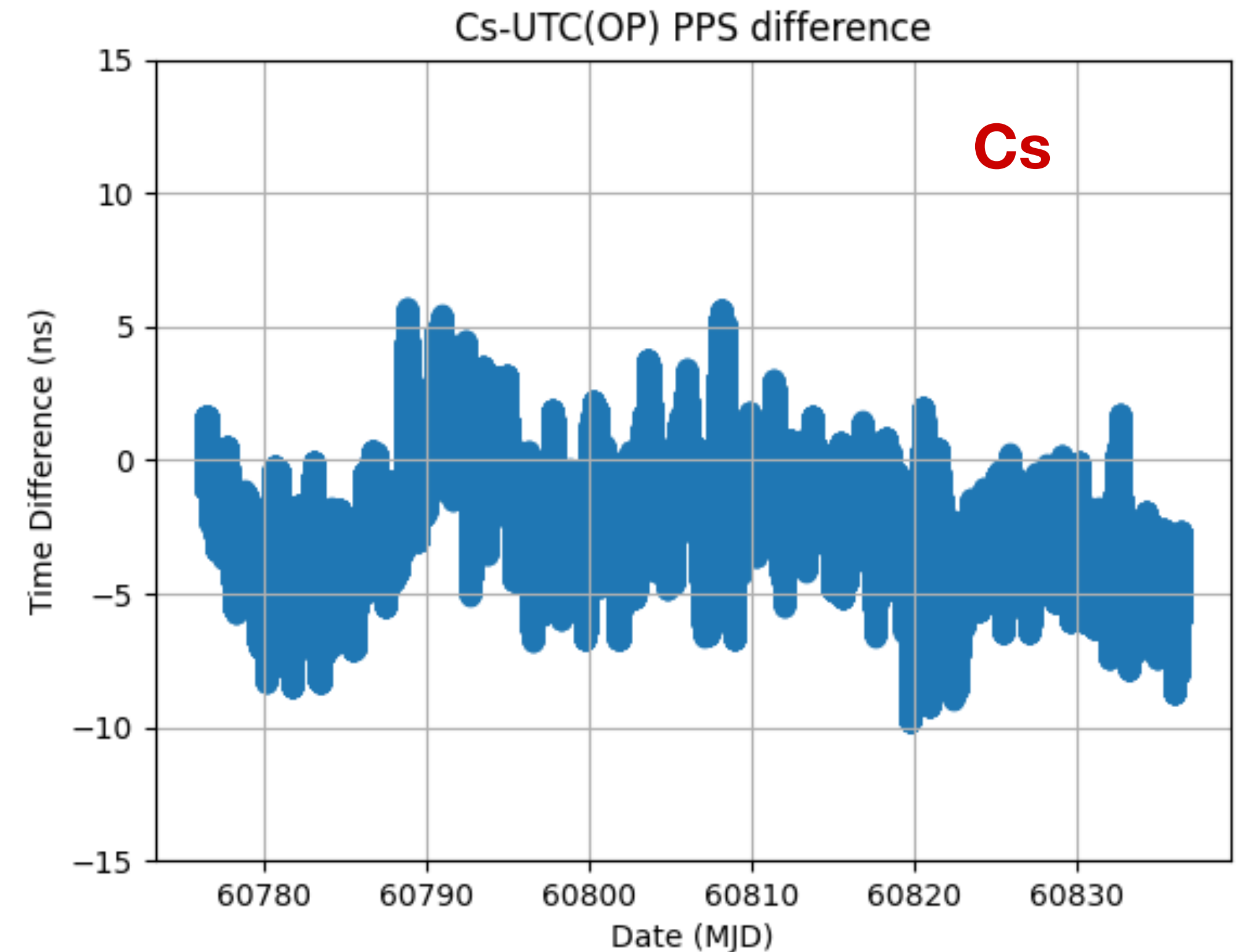

Correction using last 100 measurements

Time synchronisation system



Receiver's tolerance

Receiver has a $\pm 500 \mu\text{s}$ **tolerance**. If exceeded, the measurement **jumps by 1 ms**

For the **Rubidium clock**, a 1 ms drift happens in a **few months** whereas it takes ~ 100 years for the Cs clock

Need to take this issue into account: **remove the jump** from the correction or prevent it by **correcting the frequency drift**

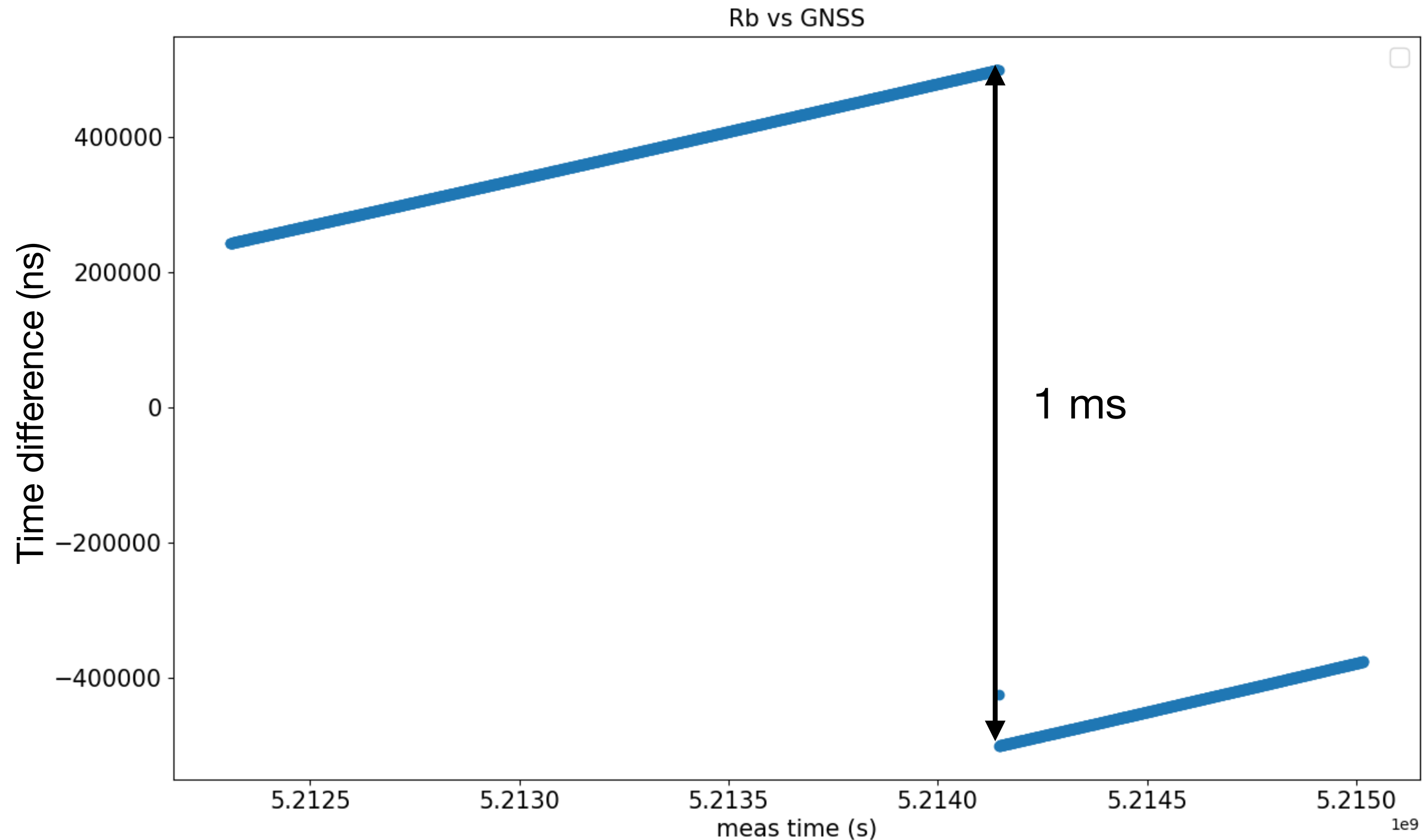

Time synchronisation system

Clock stability: Allan deviation

The **Allan Standard Deviation** is used to **characterise the stability** of a signal compared to another using **frequency ratio** y . For N measurements, we split the measurement time into K time intervals of a given length τ .

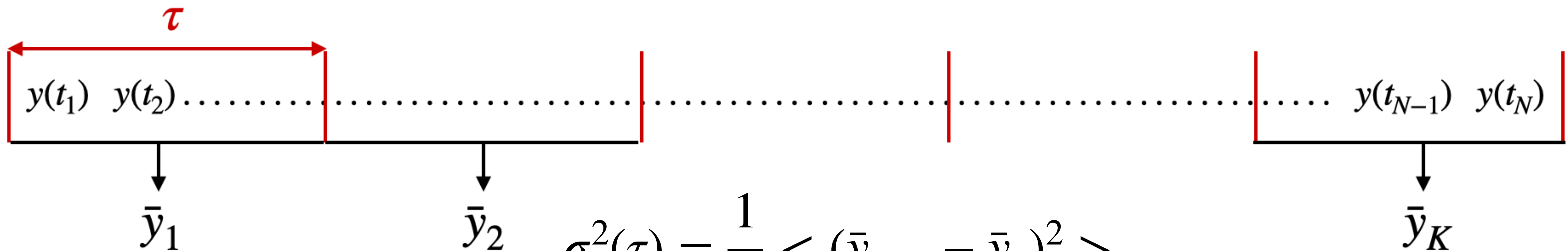

Difference of the mean of y for two consecutive intervals of length τ

A similar formula can be derived for overlapping intervals and for time differences instead of frequency ratios

Time synchronisation system

Clock stability: Allan deviation

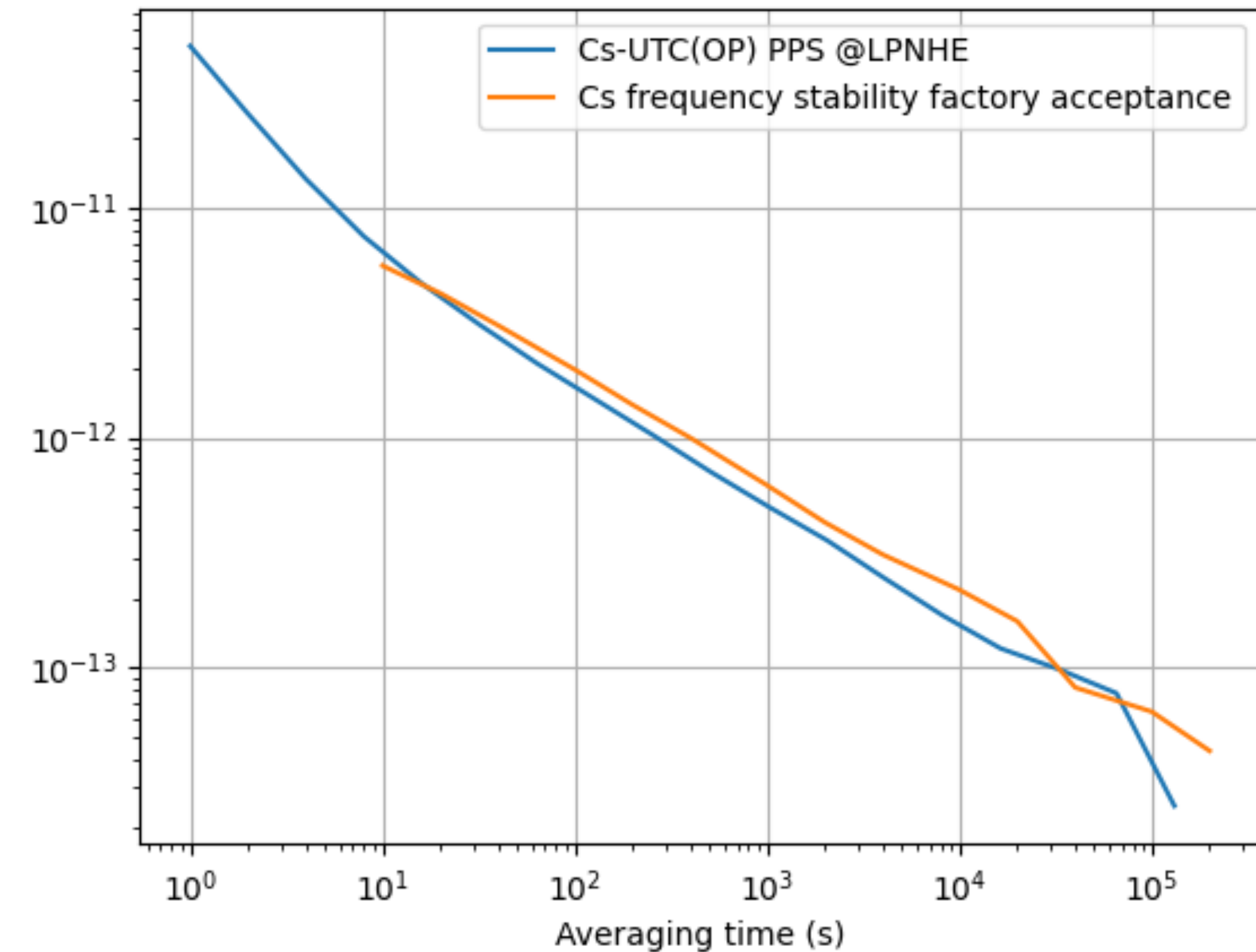
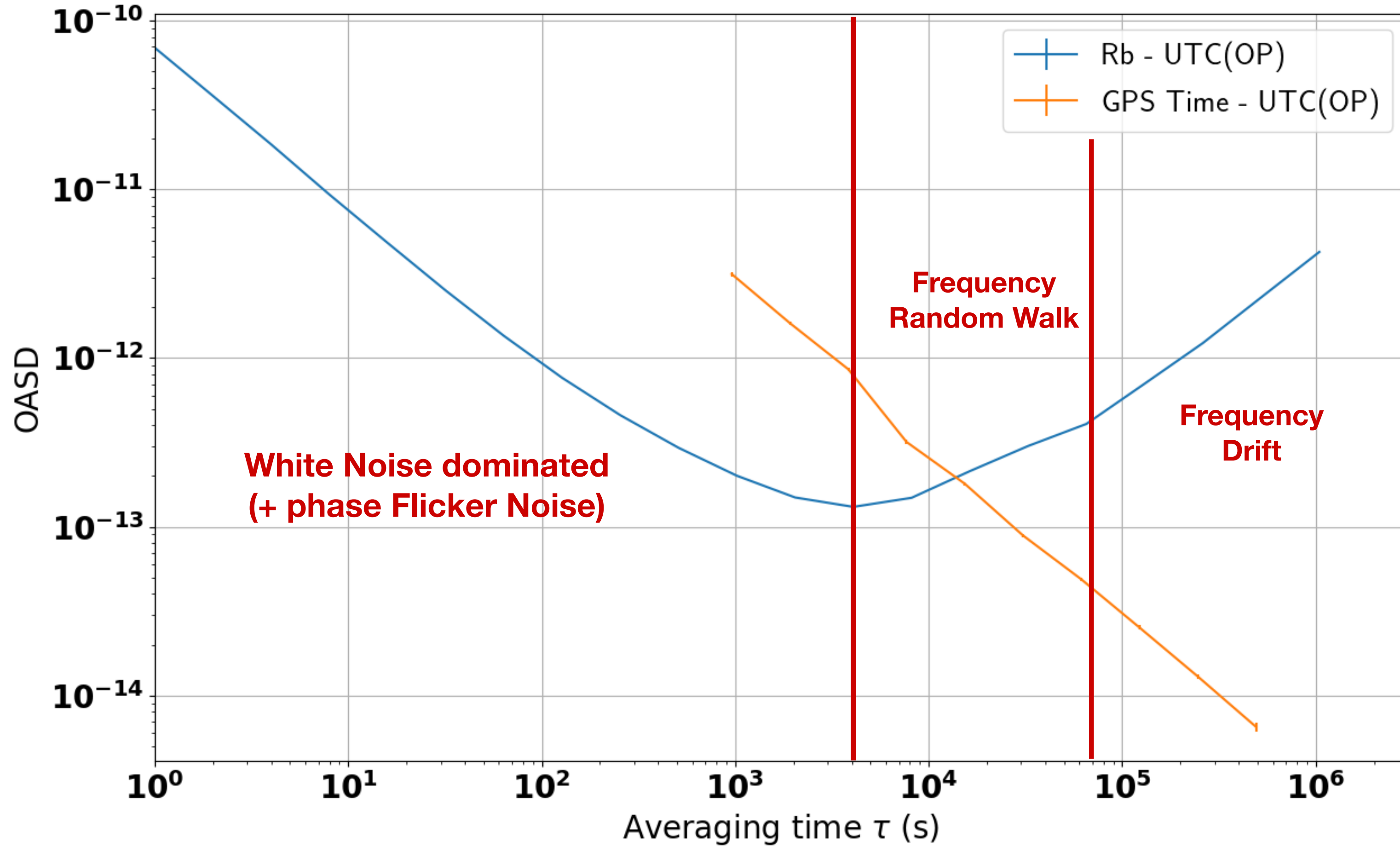

Time synchronisation system

GNSS Time based correction

- Fit the local - GNSS Time measured by Septentrio receiver with piece-wise polynomial functions of time:

$$\forall t \in [t_k, t_k + \Delta t], t_{Rb} - t_{GNSS} = a_k \cdot t^2 + b_k \cdot t + c_k$$

- Correct local time signal by subtracting the fit result in “**offline**” or “online” mode:

Offline: $\forall t \in [t_k, t_k + \Delta t], t_{Rb,corr} = t_{Rb} - (a_k \cdot t^2 + b_k \cdot t + c_k)$

We need the Septentrio measurement up to $t_k + \Delta t$ to correct Rb signal at t_k : this correction can only be applied a posteriori (offline)

Time synchronisation system

GNSS Time based correction



Hyper-Kamiokande

Offline correction

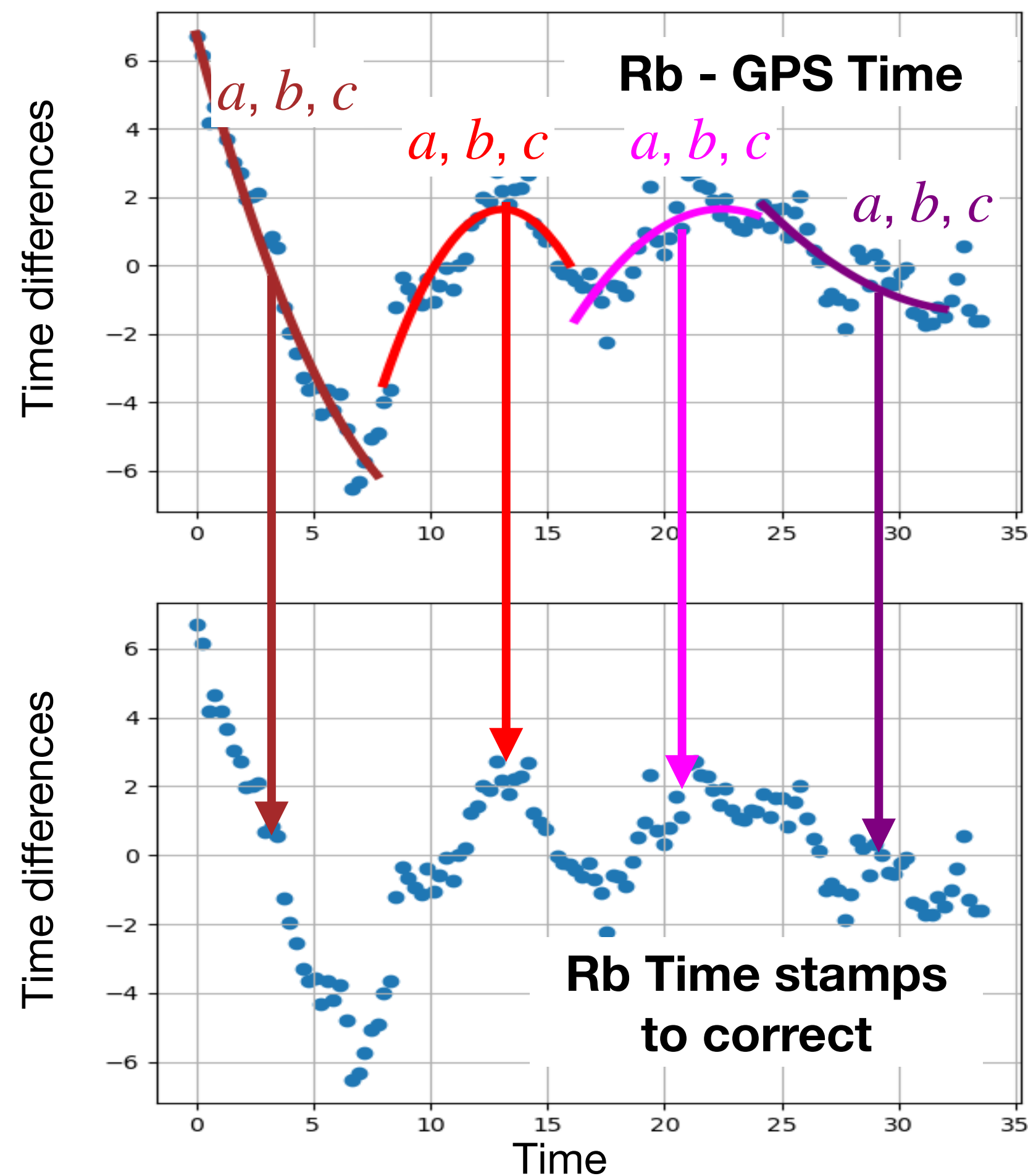

Online correction

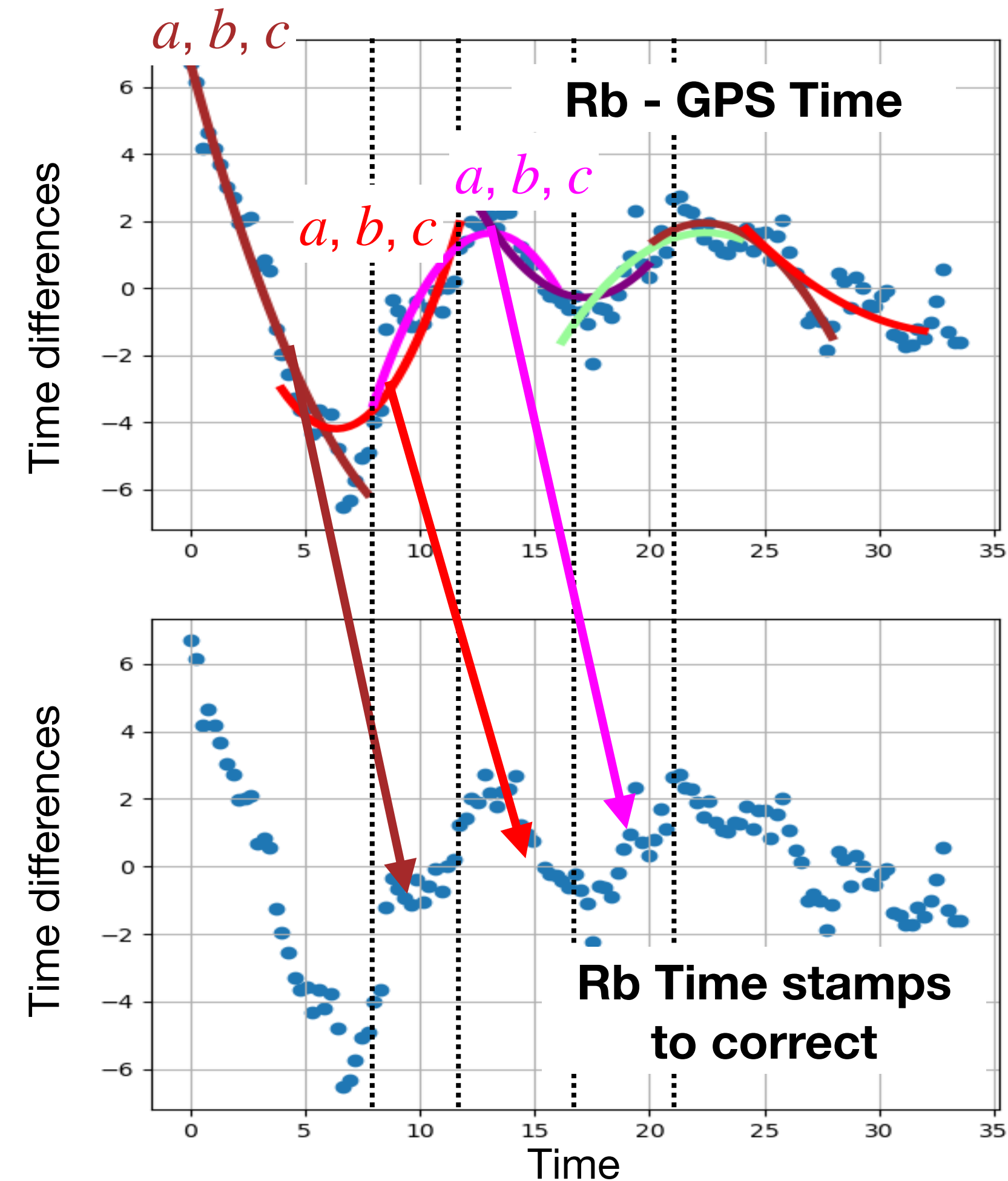

Time synchronisation system

Correction optimisation



Rb - GPS Time

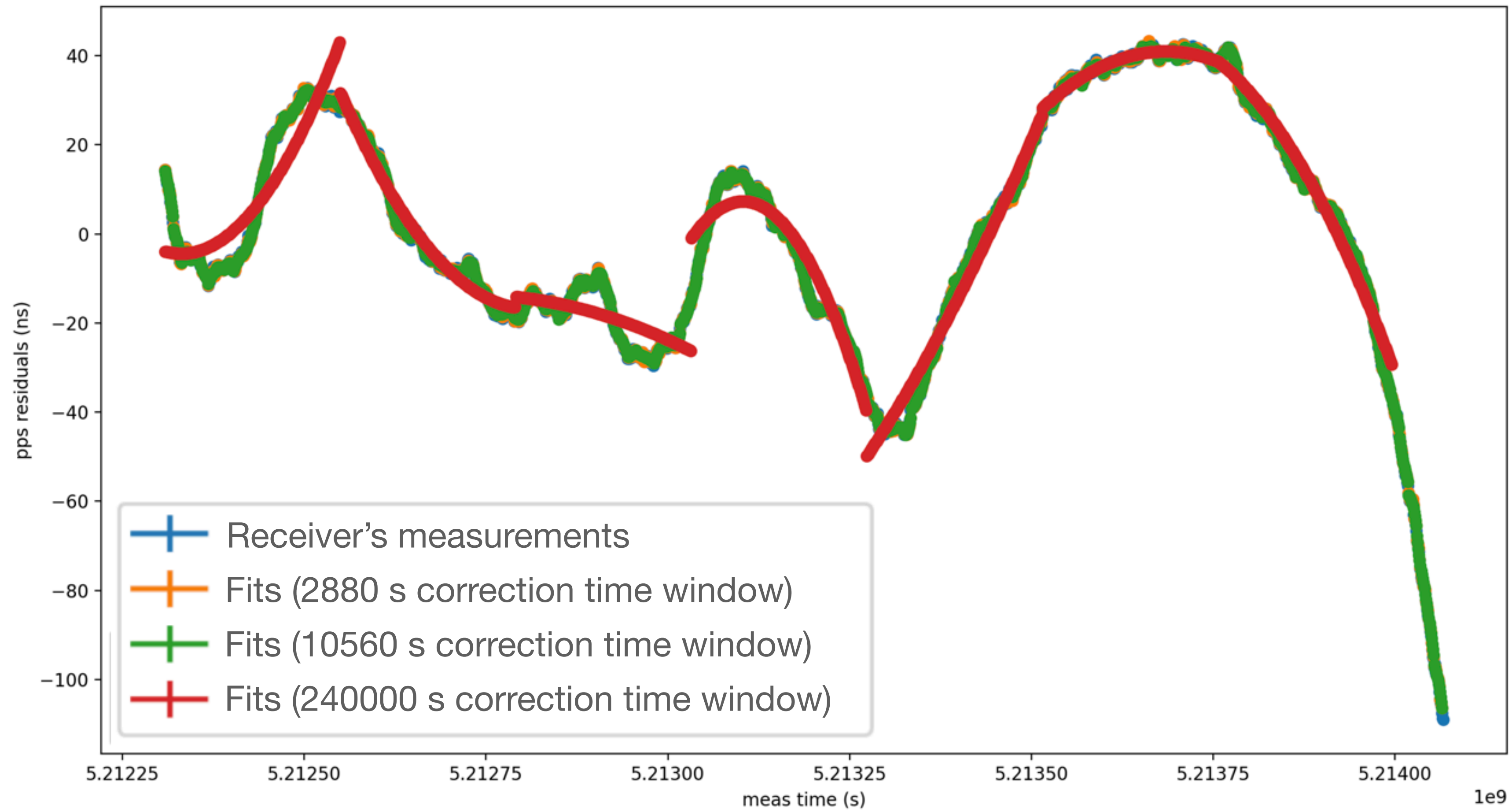

Time synchronisation system

Correction optimisation

Rb - GPS Time difference after online correction

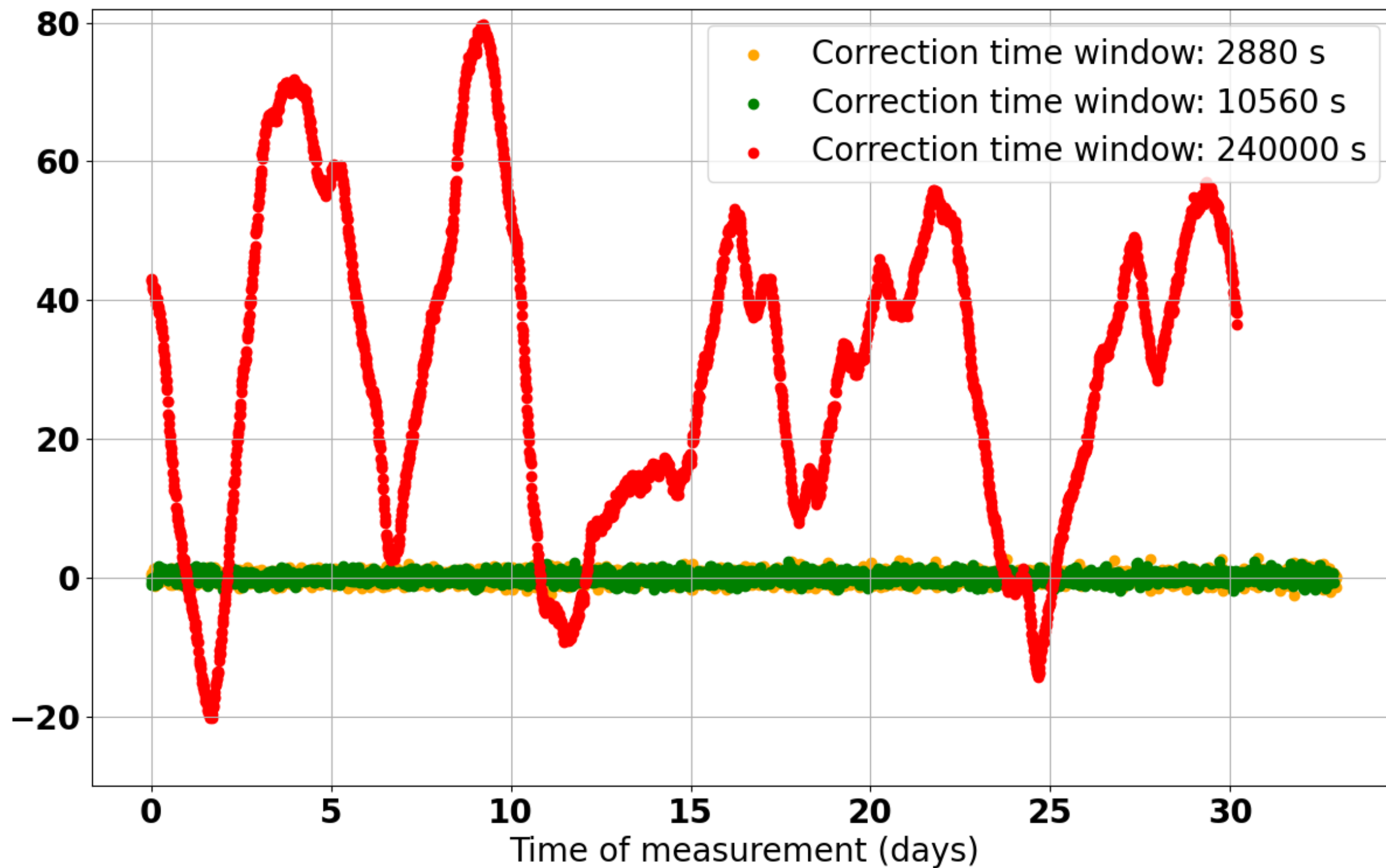

Rb vs UTC(OP)

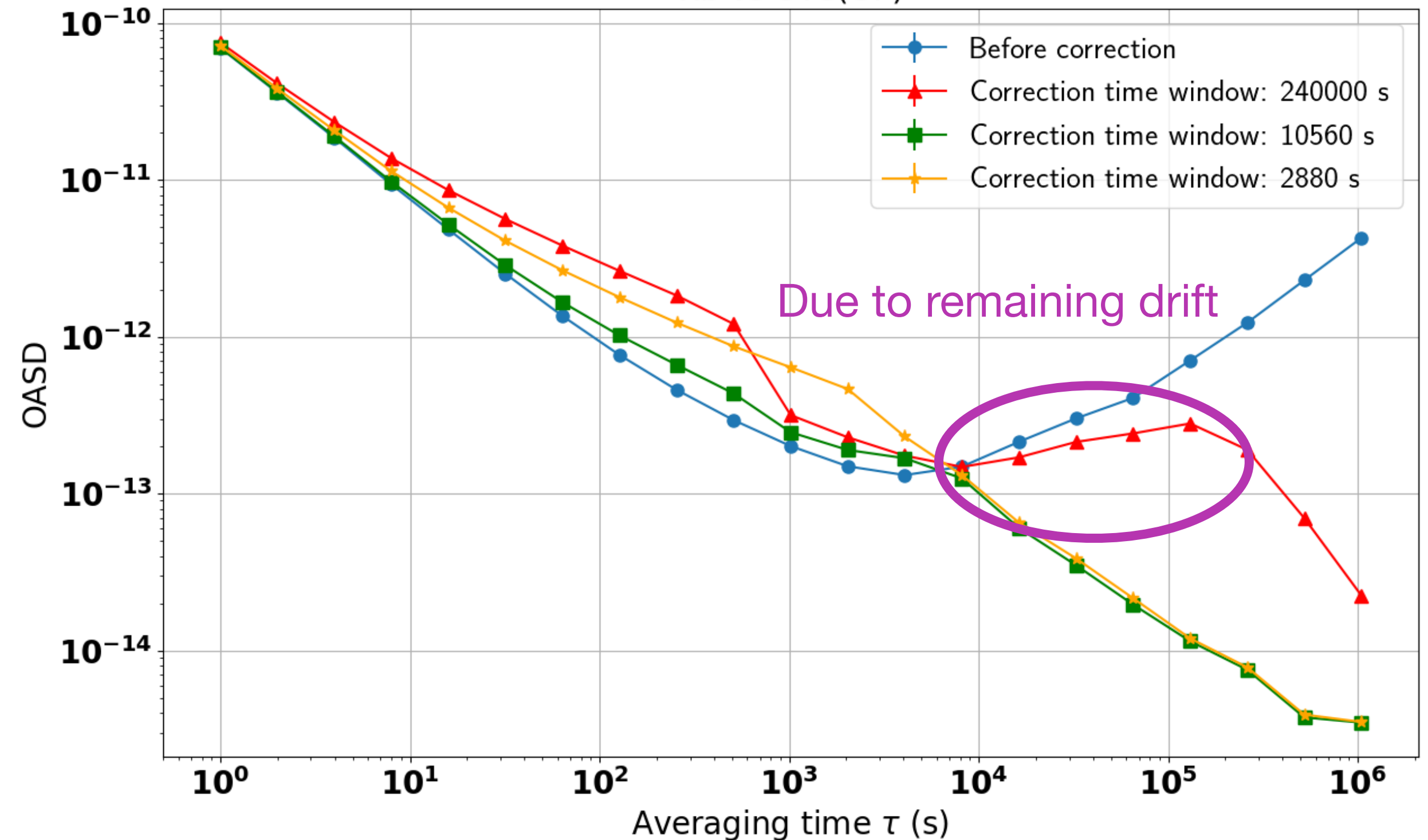

For both offline and online method, found **optimal time window** of around 10,000 seconds (**~10 receiver measurements**) for the Rubidium clock

Time synchronisation system

Correction optimisation

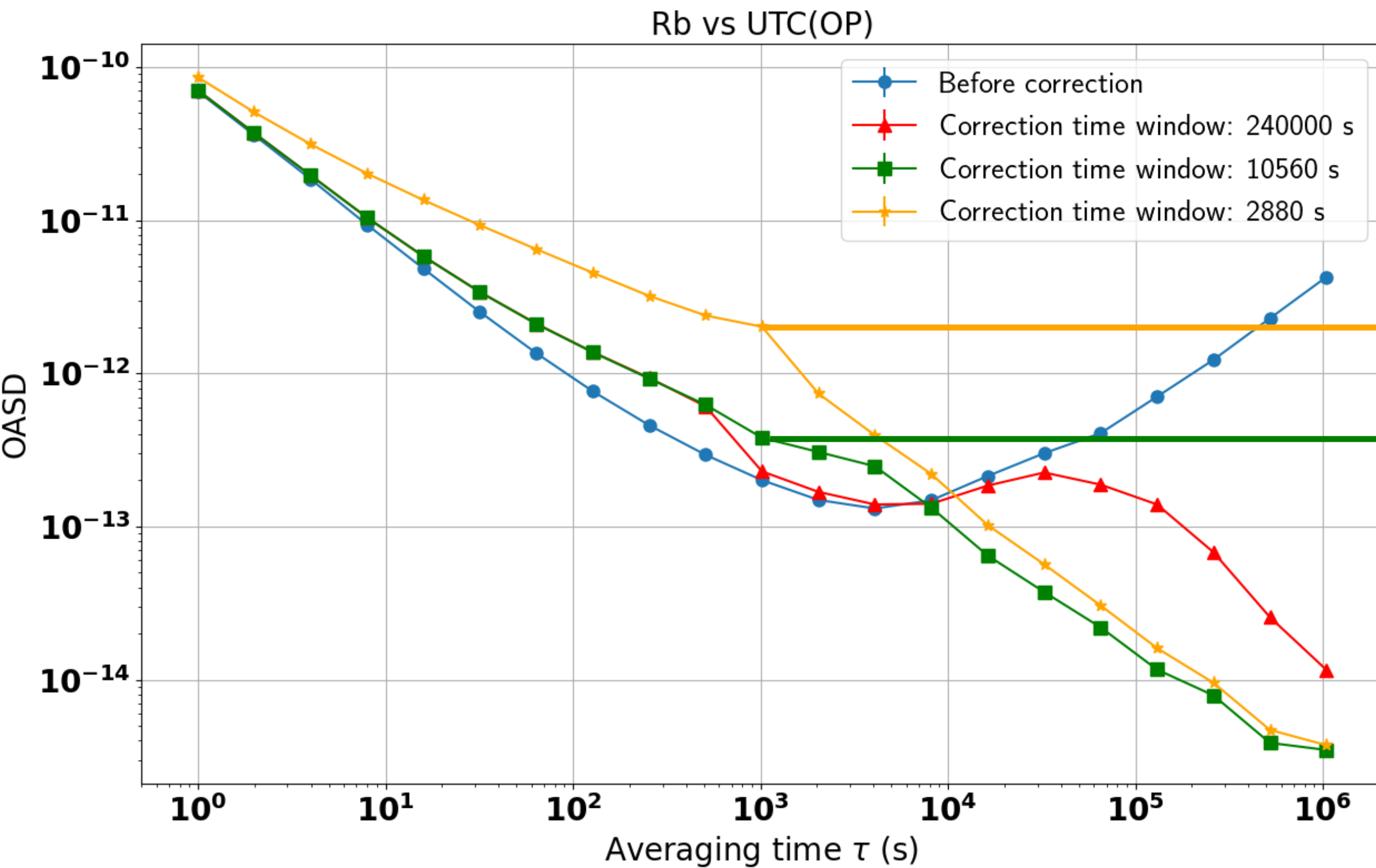

Quadratic fits of receiver's measurements

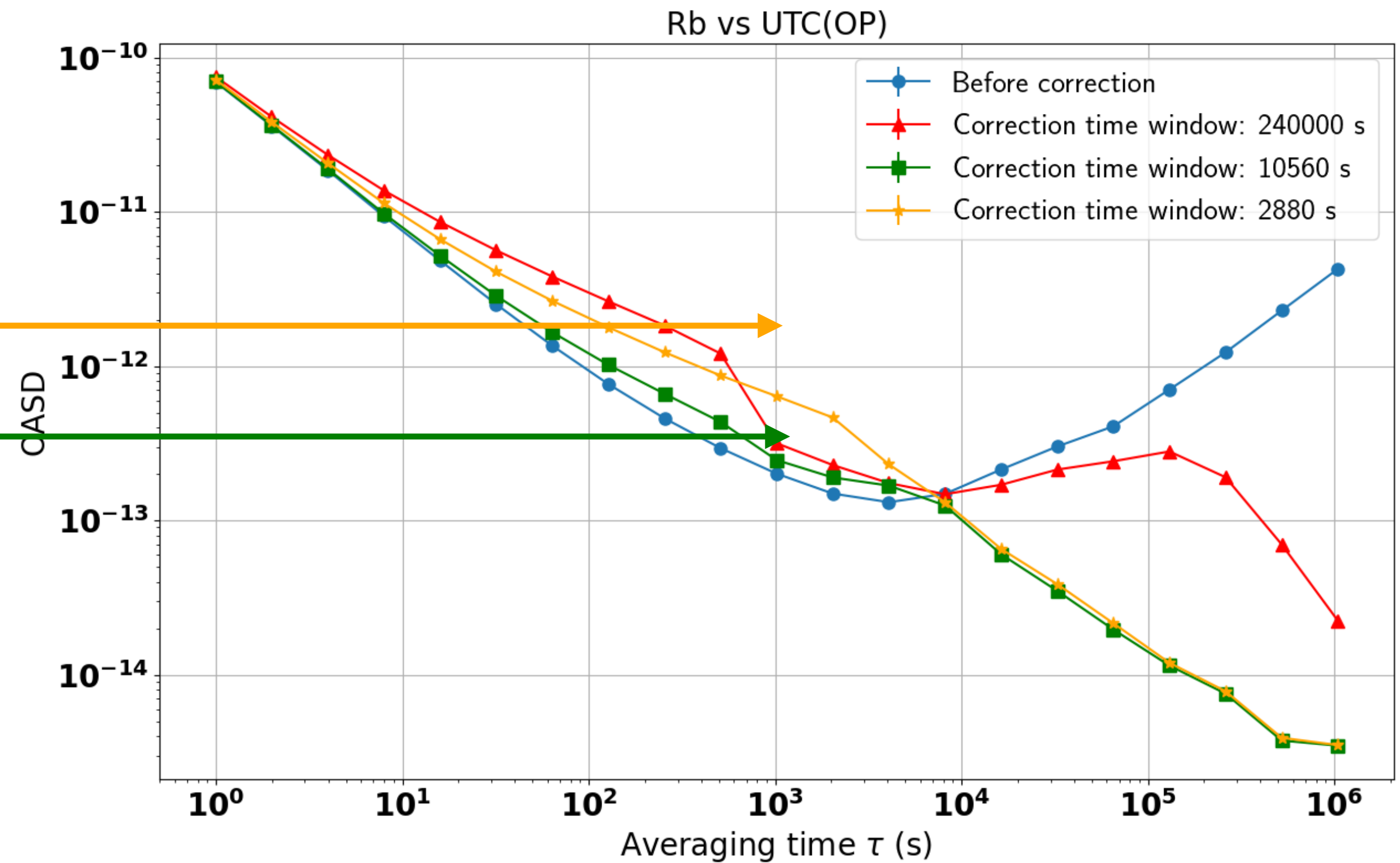

Linear fits of receiver's measurements

In online mode, linear fits are more suited (less over-fitting).

Time synchronisation system

Real-time correction



- Now that correction method was optimised, the online version can be **applied in real-time**
- Using **MIDAS DAQ software** to:
 - ▶ **Store** local - GNSS Time and local - UTC(OP) measurements
 - ▶ **Extract correction** to apply from local - GNSS Time measurements
 - ▶ **Apply correction in real-time** to local - UTC(OP) measurements
 - ▶ **Store corrected** local - UTC(OP) measurements

Time synchronisation system



Real-time correction

- Now that correction method was optimised, the online version can be **applied in real-time**
- Using **MIDAS DAQ software**
- **Correction** coefficients are **updated** every time a **new local - GNSS Time measurement is available**:
 - ▶ New **measurement added** on top of the queue
 - ▶ The **older one is rejected** from the queue (**queue length constant**)
 - ▶ **Correction** coefficients **extracted from the fit** of the points in the queue

Time synchronisation system

Real-time correction



Hyper-Kamiokande

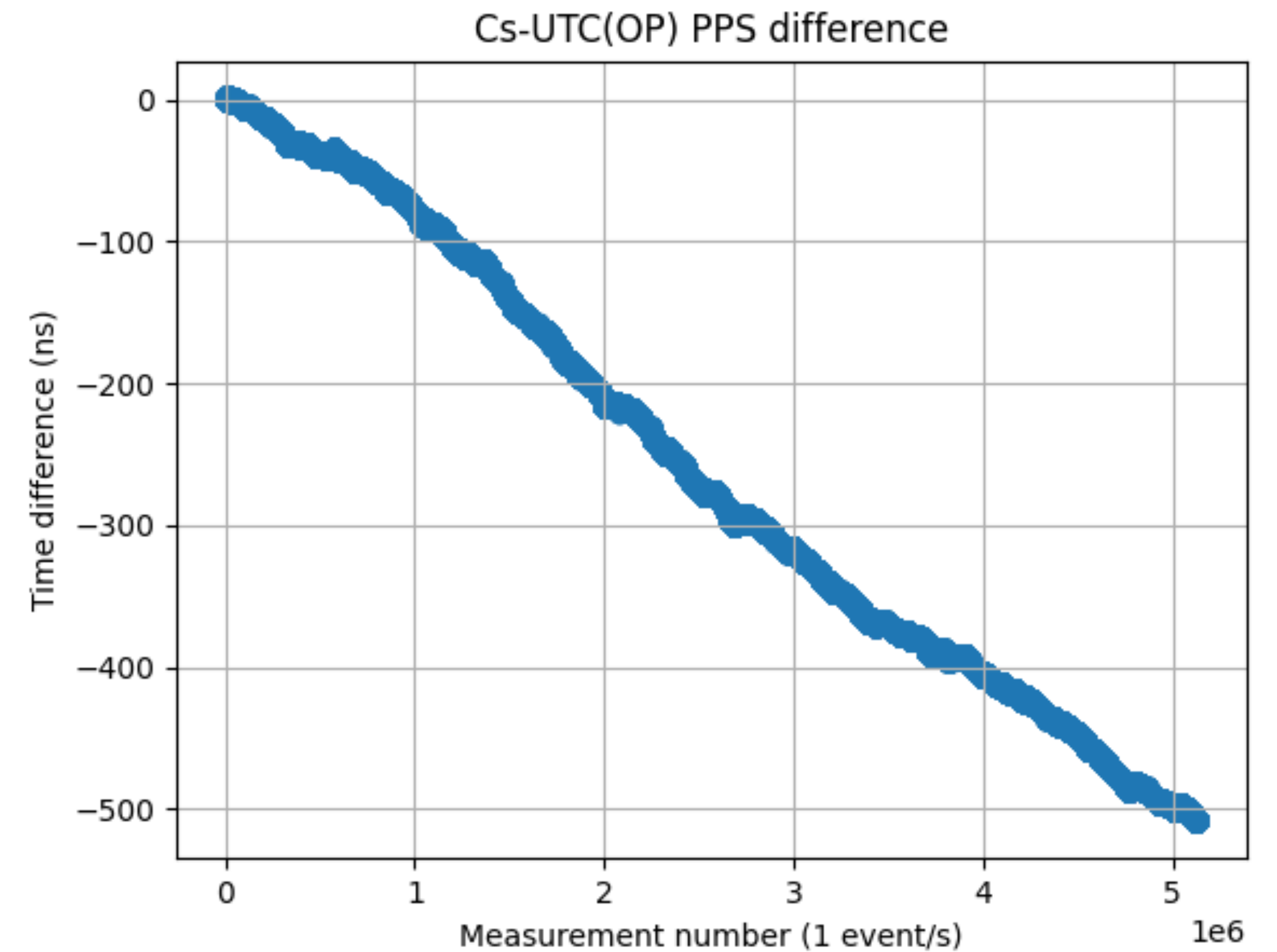
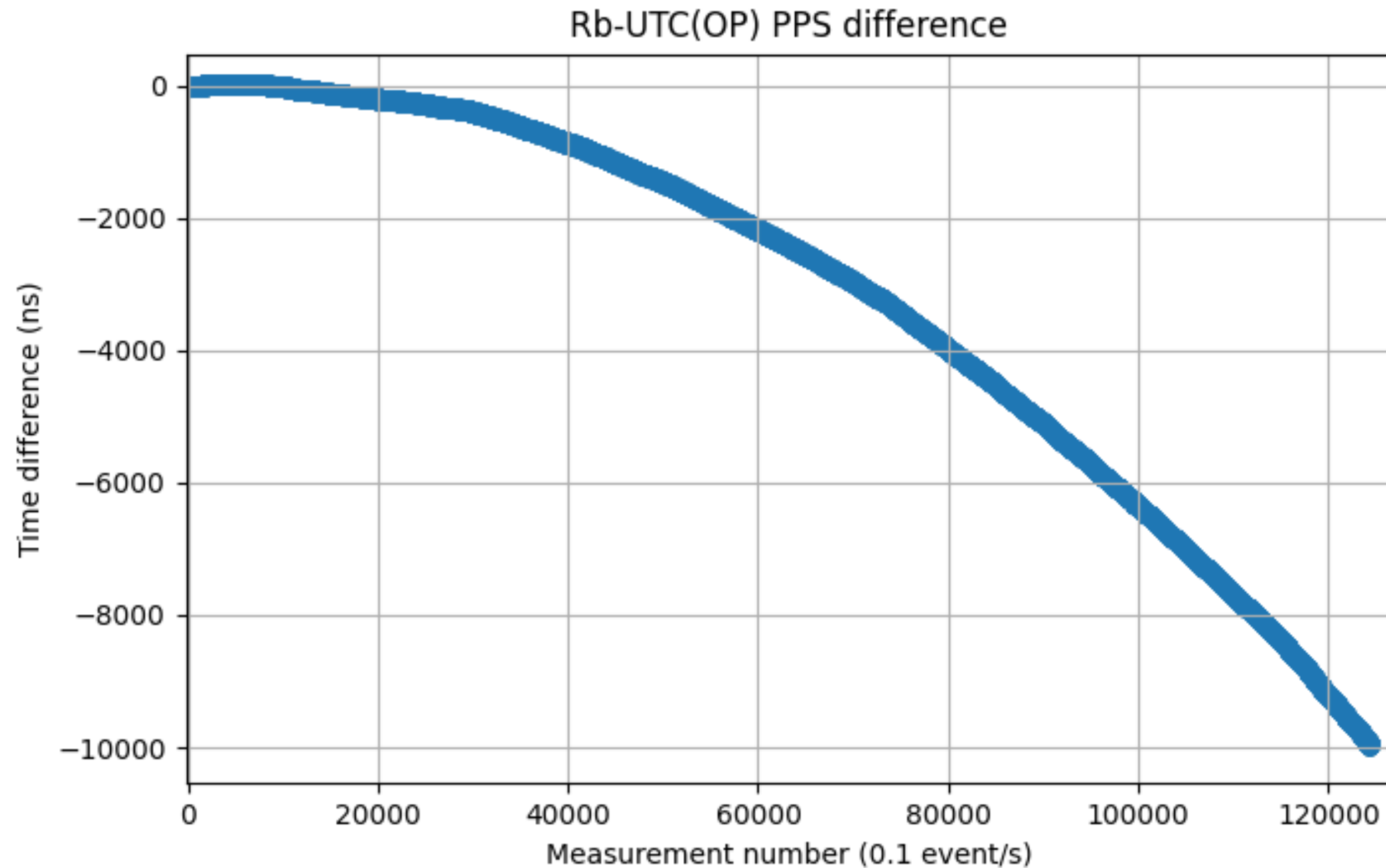

Cs clock PPS drifts much slower compared to Rb: **linear drift typical of frequency mis-calibration**.
Continuous monitoring of drift is still needed in case of ageing.

Time synchronisation system

Rubidium frequency correction

The user can change the Rb frequency via the SF parameter:

$$\Delta SF = 1 \leftrightarrow \delta f/f = 10^{-12}$$

With the receiver's measurements, we can **monitor** the error on the **frequency and correct** it regularly.

This method will **interfere with the time correction!**

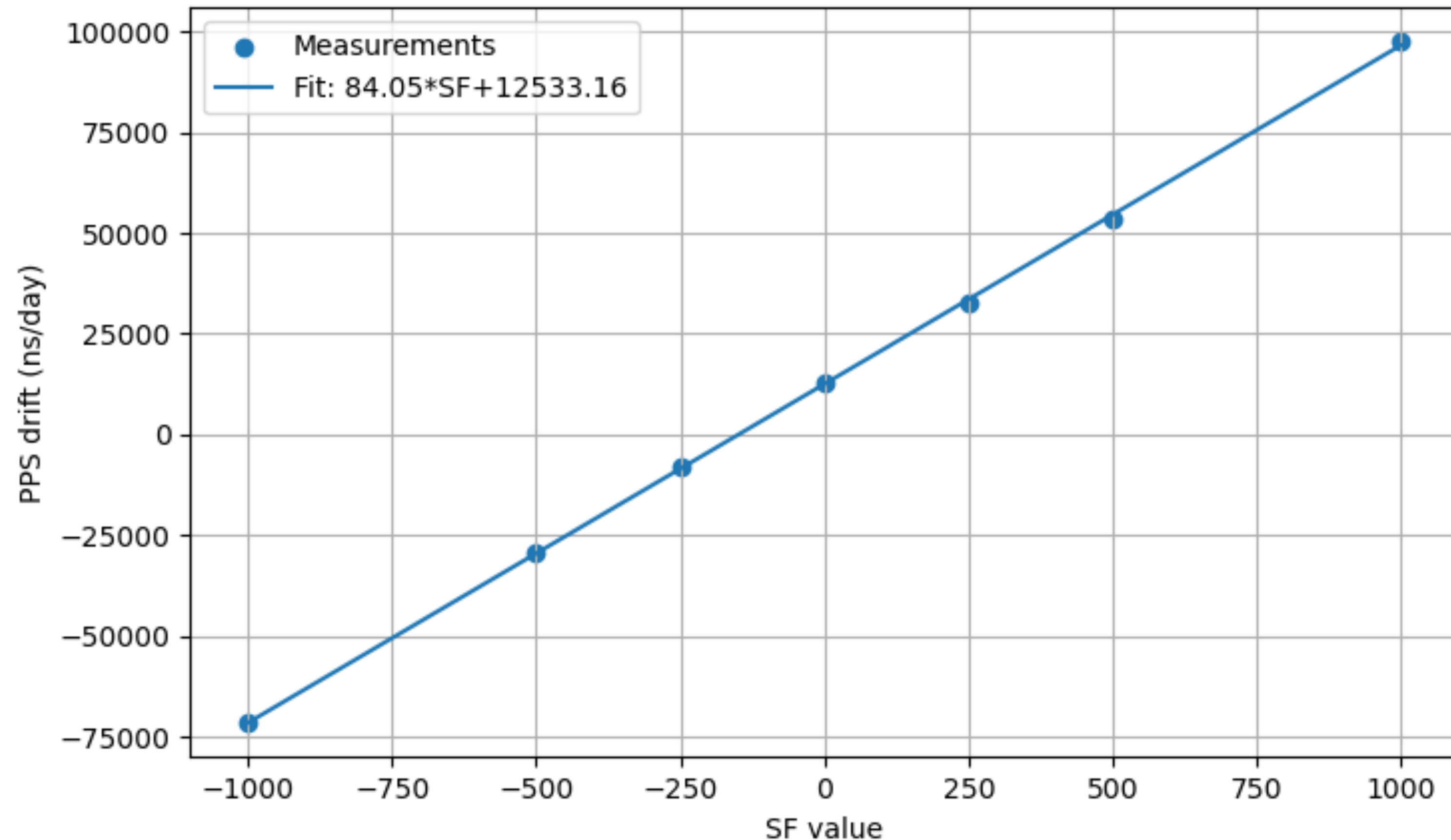

Long baseline program

Overview

LBL program built from same 295 km **T2K baseline**

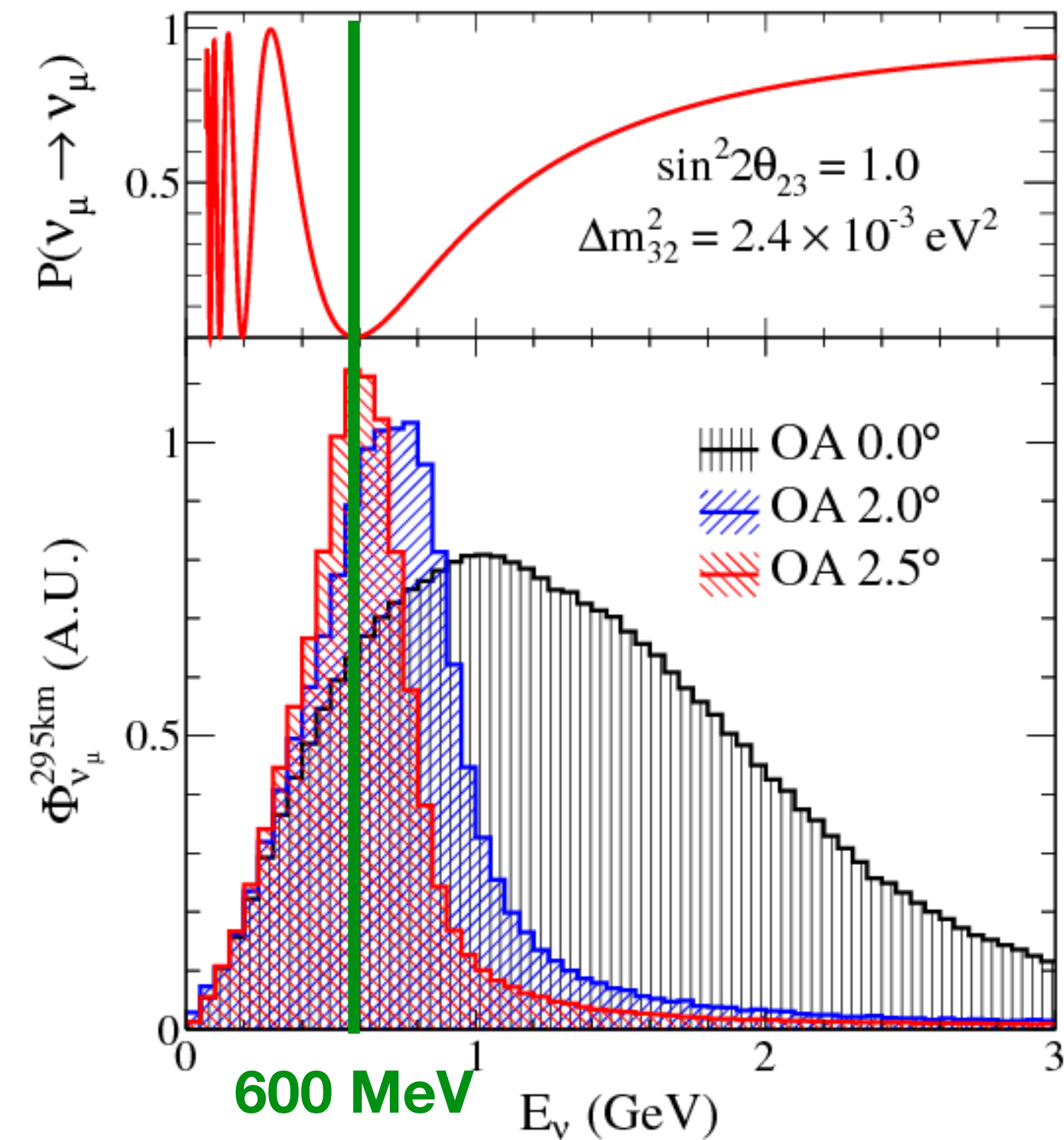
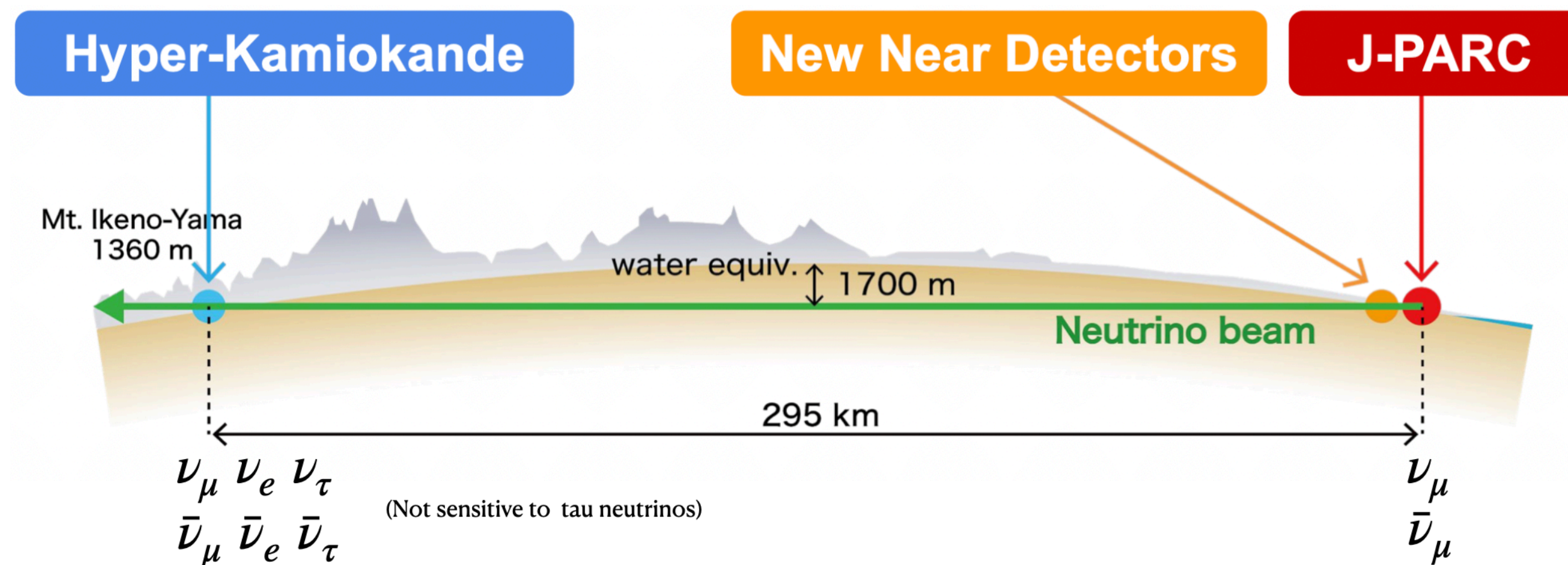

ν_μ ($\bar{\nu}_\mu$) beam produced at **J-PARC accelerator facility**

Off-Axis technique allows:

- ▶ Narrow energy band peaked at 600 MeV
- ▶ Maximise $\nu_\mu/\bar{\nu}_\mu$ disappearance and $\nu_e/\bar{\nu}_e$ appearance at SK/HK

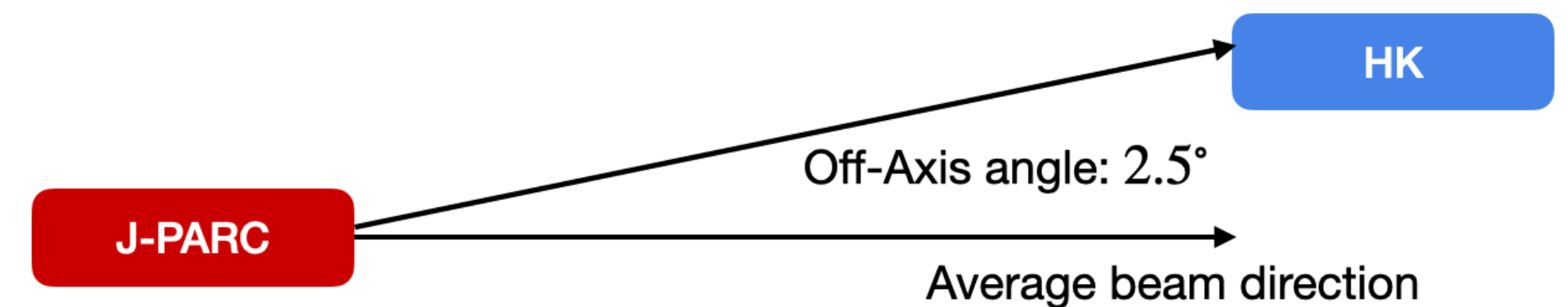

Hyper-Kamiokande

Long baseline program

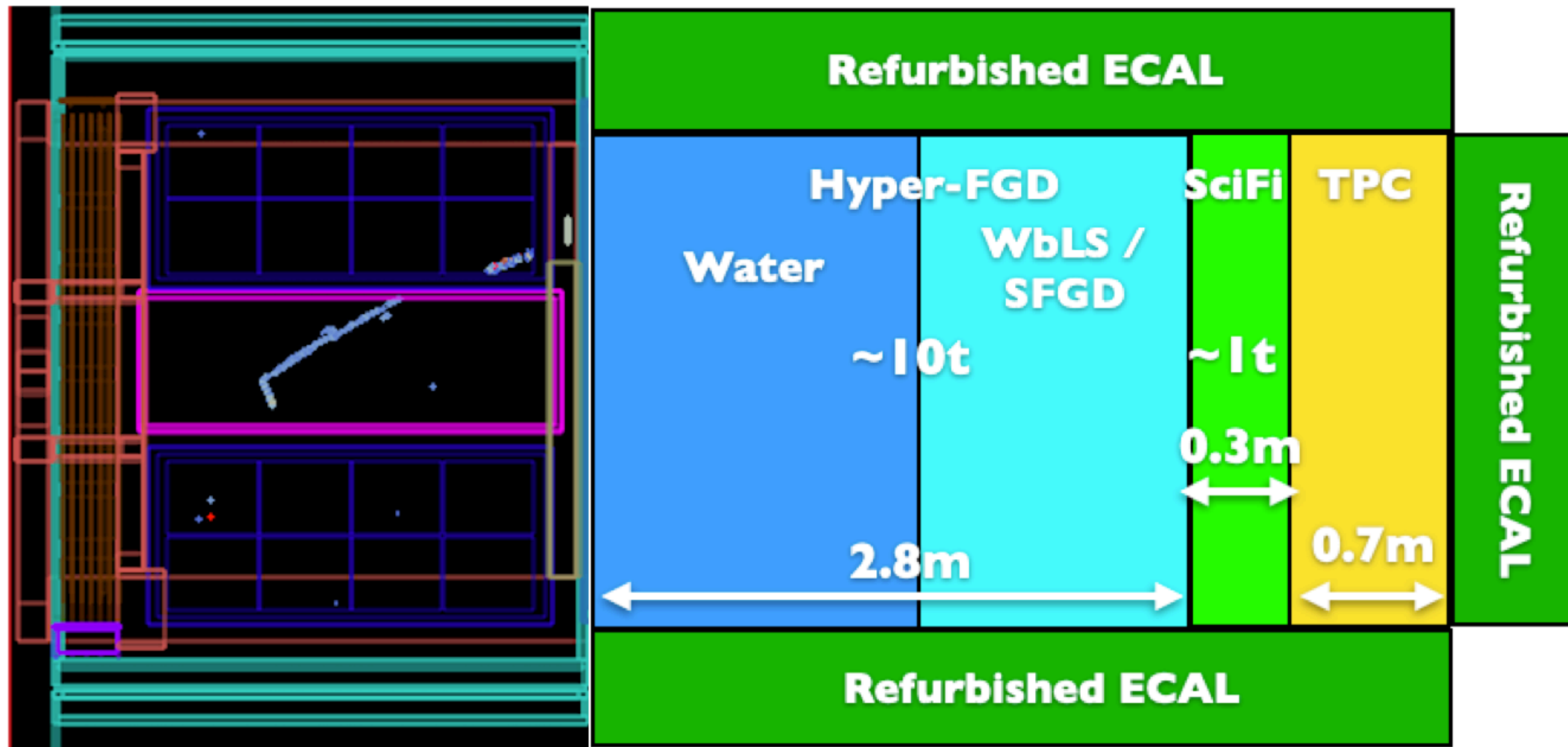

Possible design of ND280++ (Davide Sgalaberna, NuFact 2025)

Hyper-Kamiokande



Long baseline program

IWCD would present a lot of advantages to reduce neutrino interaction uncertainties:

- Same target material and detector technology as FD
- Vertically movable = varying off-axis angle: allows to scan different flux configurations and increase statistics at higher neutrino energies (constrain non QE interactions)

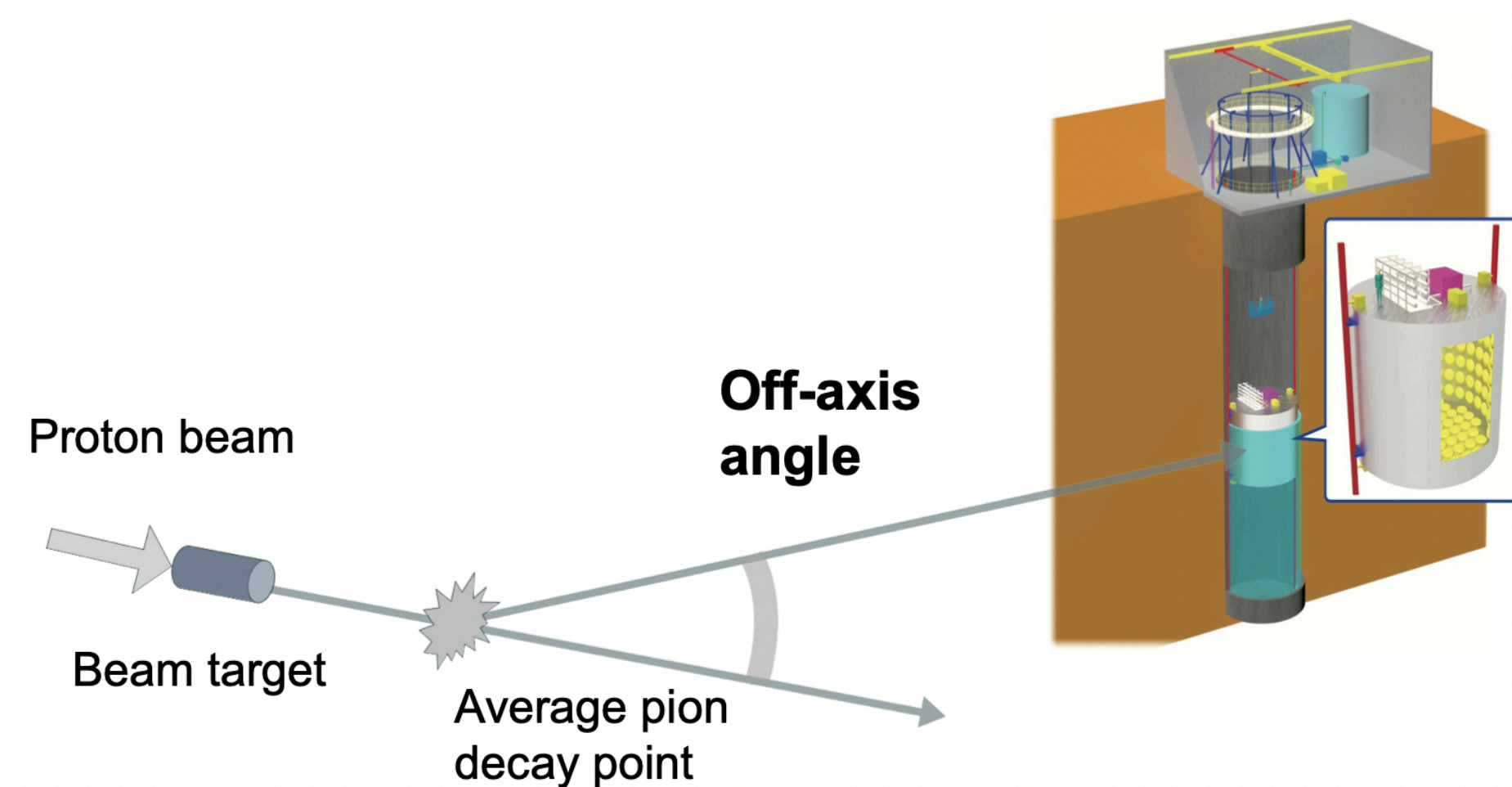

Average beam direction

ν
Off-axis angle

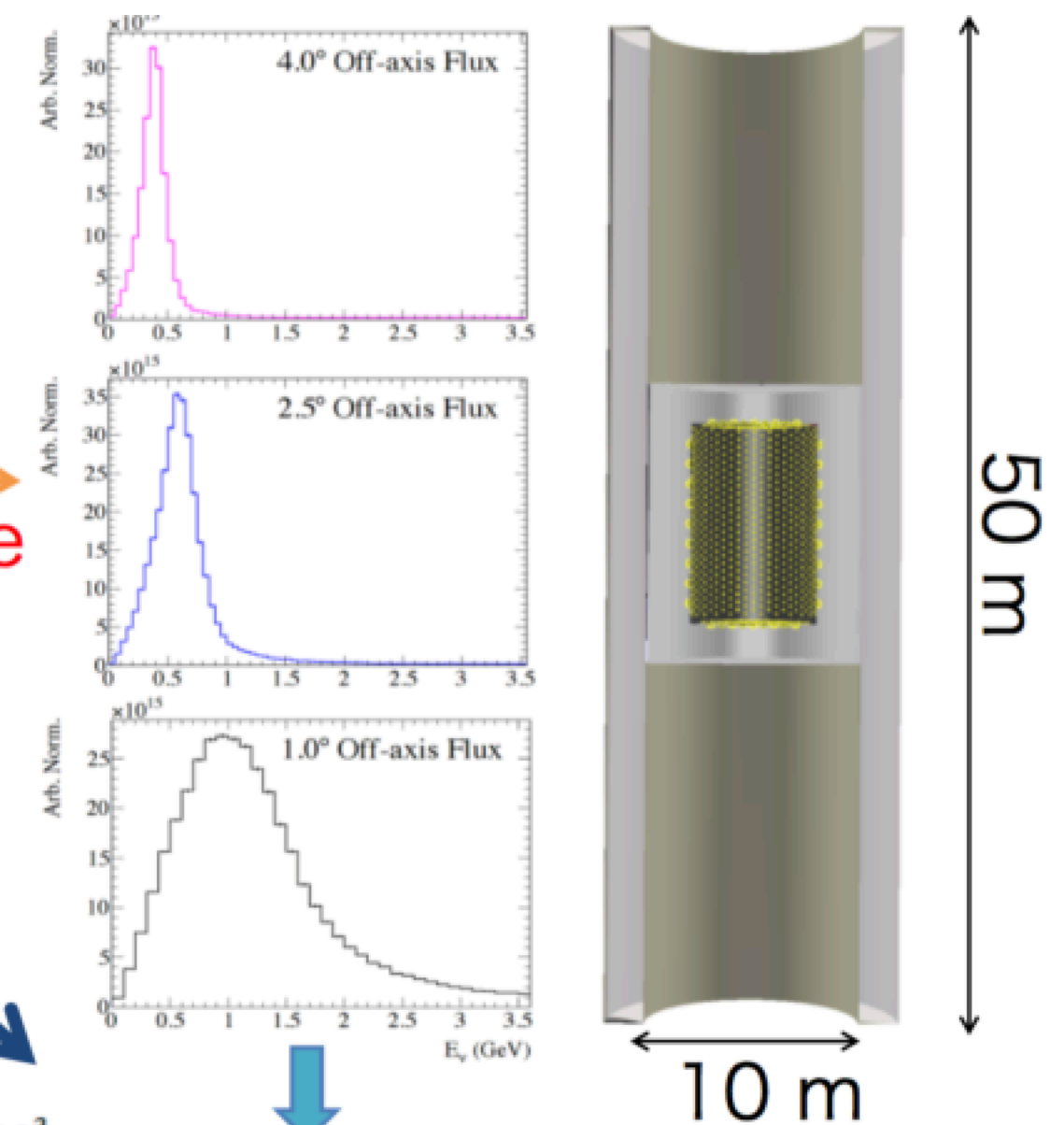

Hyper-Kamiokande

Long baseline program



Hyper-Kamiokande

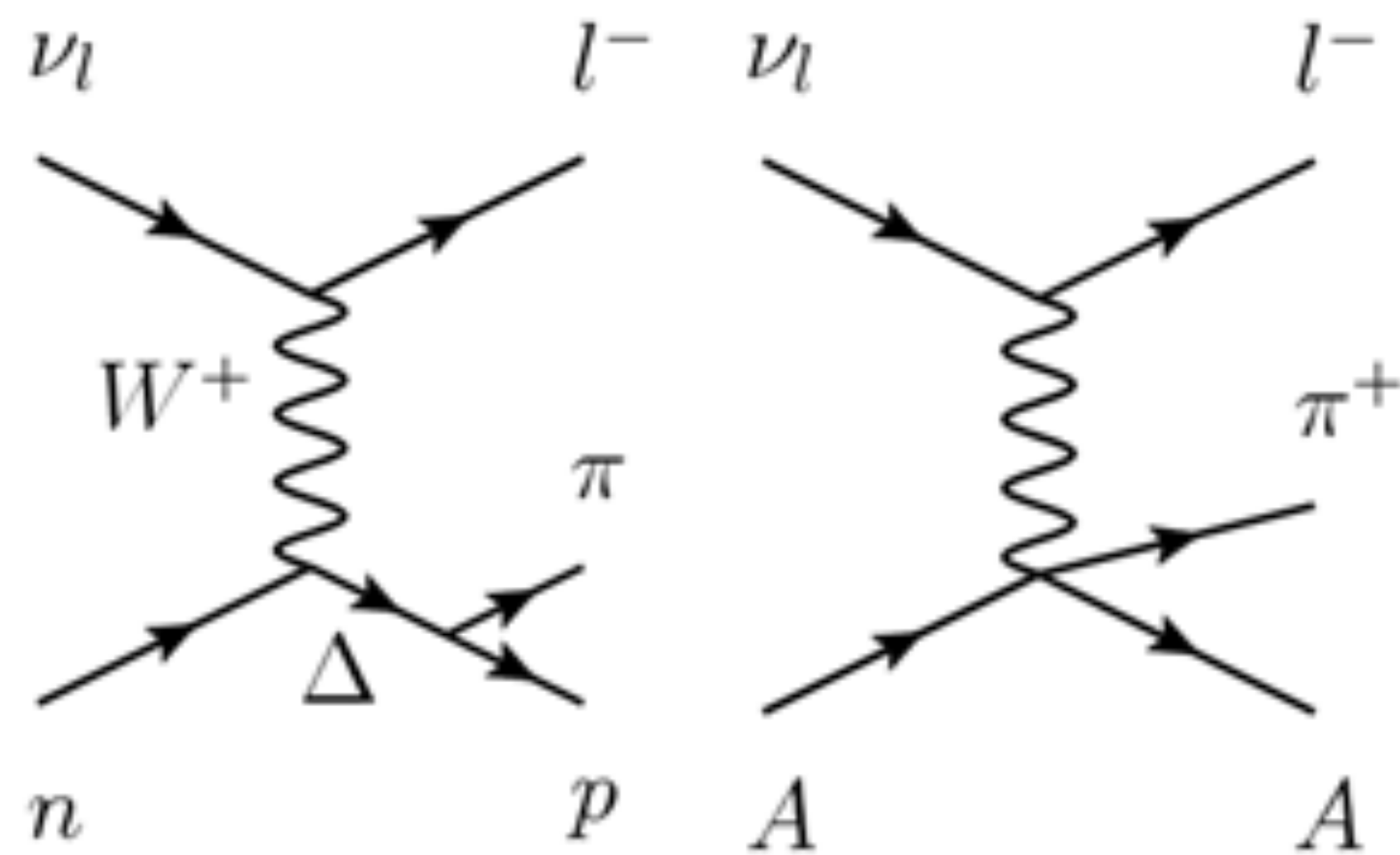

Pion production (resonant or coherent):
energy reconstruction is biased if the
pion is missed or absorbed by the
nucleus

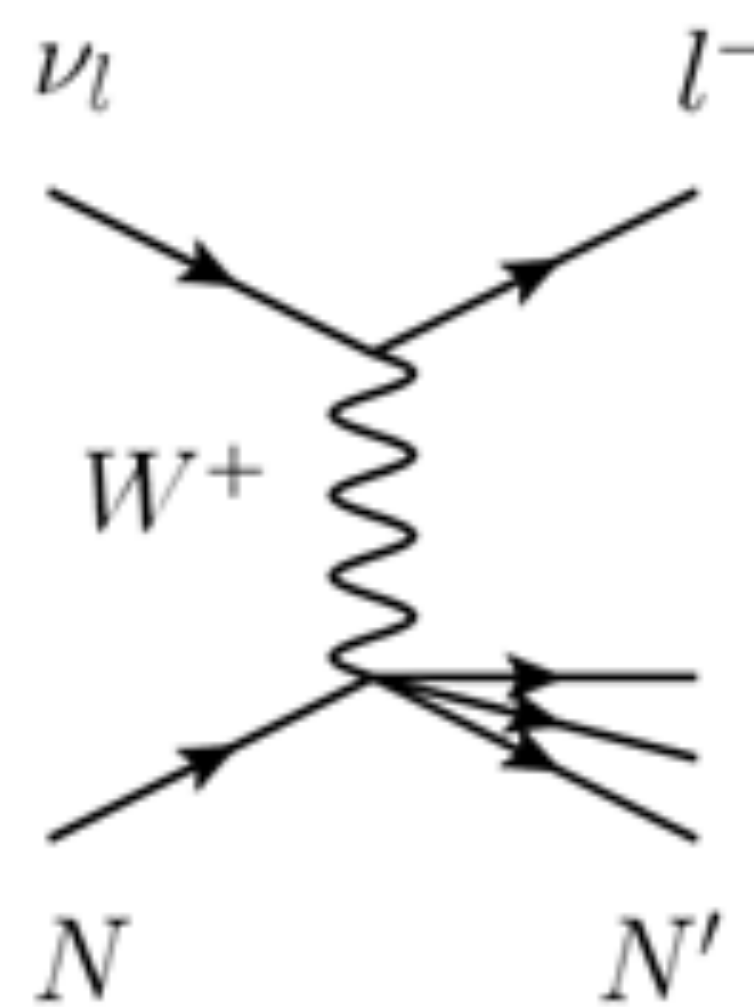

Deep Inelastic
Scattering (>1 GeV)

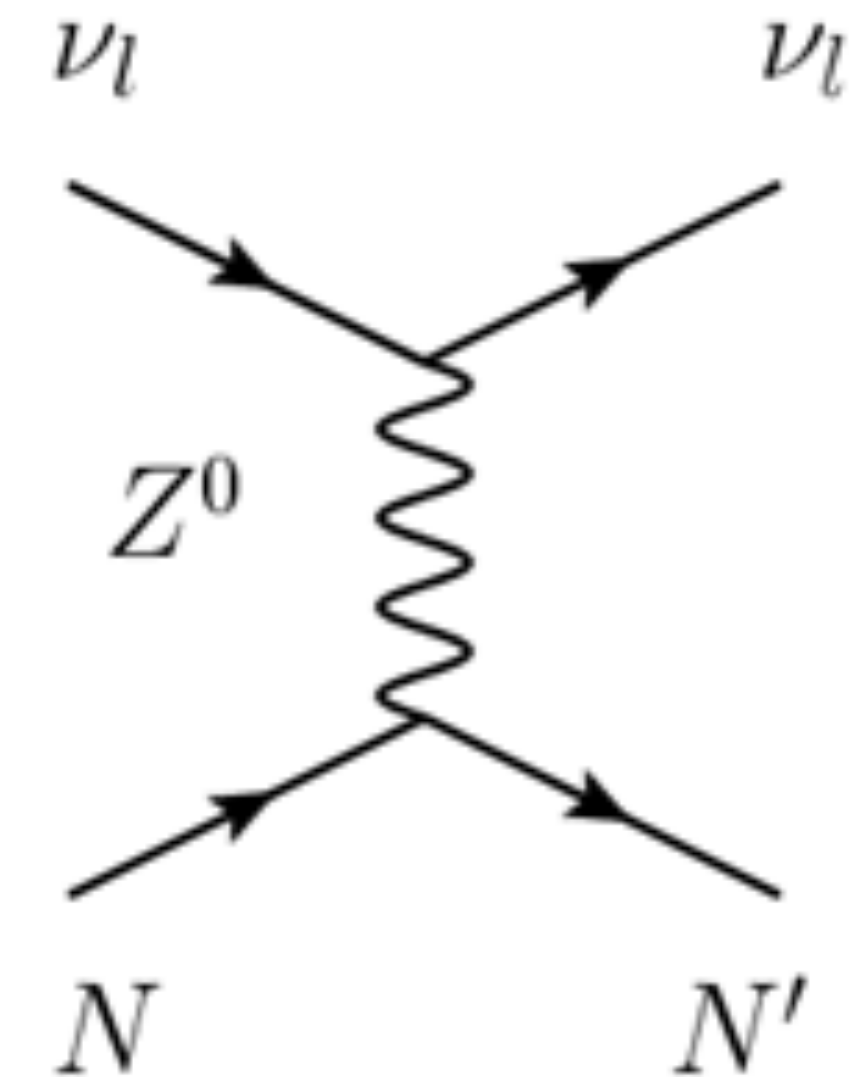

Neutral Current
interaction: loose
information on flavour

These effects (and others) are included as systematic uncertainties

Long baseline program

Physics goal

By **comparing** the **Near and Far** detector measurements, we study

- **Muon flavour disappearance**

Symmetric around $\sin^2 \theta_{23} \approx 0.5$: octant degeneracy

$$P(\nu_{\mu} \rightarrow \nu_{\mu}) \approx 1 - \sin^2(2\theta_{23}) \sin^2 \left(\frac{\Delta m_{32}^2 L}{4E_{\nu}} \right)$$

Sensitive to $|\Delta m_{32}^2|$

- Electron flavour appearance

Long baseline program

Physics goal

By **comparing** the **Near and Far** detector measurements, we study

- Muon flavour disappearance
- **Electron flavour appearance**

T2K excluded CP symmetry at 2σ with $\delta_{CP} \approx -90^\circ$: result limited by statistics

$$P(\bar{\nu}_\mu \rightarrow \bar{\nu}_e) - P(\nu_\mu \rightarrow \nu_e) =$$

$$16 \cos^2 \theta_{13} \cos \theta_{12} \cos \theta_{23} \sin \theta_{12} \sin \theta_{13} \underbrace{\sin \theta_{23} \sin \delta_{CP}}_{\text{Sensitivity to CP violation}} \cdot \underbrace{\sin \theta_{23}}_{\text{Sensitivity to } \theta_{23} \text{ octant}} \cdot \sin \left(\frac{\Delta m_{32}^2 L}{4E_\nu} \right) \cdot \sin \left(\frac{\Delta m_{31}^2 L}{4E_\nu} \right) \cdot \sin \left(\frac{\Delta m_{21}^2 L}{4E_\nu} \right)$$

This is for oscillation in vacuum, need to add matter effects...



Nature 580 (2020) 7803

Long baseline program

Physics goal

- Muon flavour disappearance
- **Electron flavour appearance**

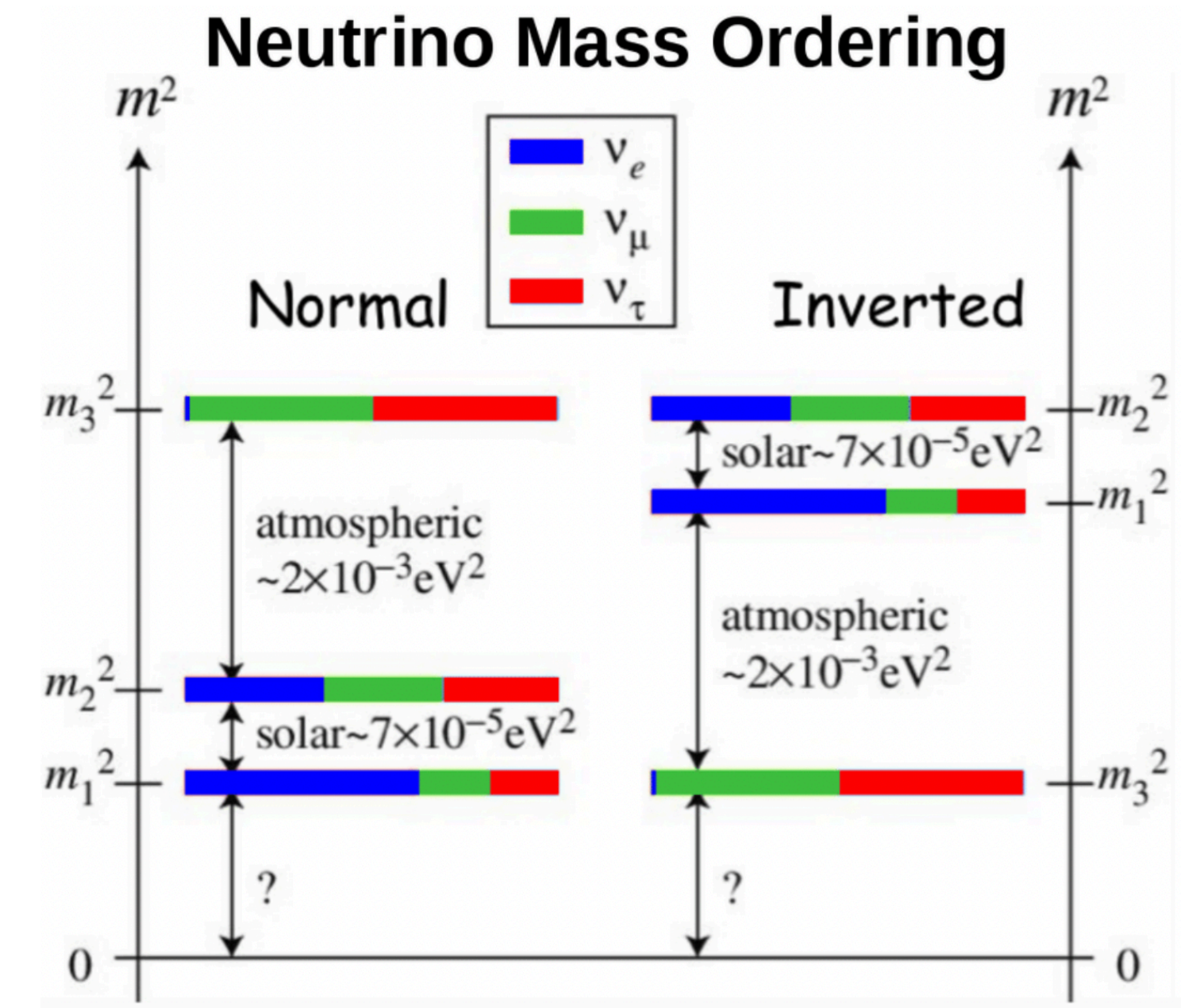

$$P(\bar{\nu}_\mu \rightarrow \bar{\nu}_e) - P(\nu_\mu \rightarrow \nu_e) =$$

$$16 \cos^2 \theta_{13} \cos \theta_{12} \cos \theta_{23} \sin \theta_{12} \sin \theta_{13} \sin \theta_{23} \sin \delta_{CP} \cdot \sin \left(\frac{\Delta m_{32}^2 L}{4E_\nu} \right) \cdot \sin \left(\frac{\Delta m_{31}^2 L}{4E_\nu} \right) \cdot \sin \left(\frac{\Delta m_{21}^2 L}{4E_\nu} \right)$$

$$+ 16 \cos^2 \theta_{13} \sin^2 \theta_{13} \sin^2 \theta_{23} (1 - 2 \sin^2 \theta_{13}) \frac{|a|L}{4E_\nu} \cos \left(\frac{\Delta m_{32}^2 L}{4E_\nu} \right) \cdot \sin \left(\frac{\Delta m_{31}^2 L}{4E_\nu} \right)$$

Matter effects proportional to L and $a = \pm 2\sqrt{2}G_F E_\nu n_e$

Bigger for atmospheric neutrinos

Sensitivity to Mass Ordering

Long baseline program

Oscillation analysis

Oscillation analysis allows to extract **constraints on oscillation parameters** from event rates

Event rates:

$$N = \underbrace{F}_{\text{Flux}} \times \underbrace{\sigma}_{\text{Cross section}} \times \underbrace{\epsilon}_{\text{Detector efficiency}}$$

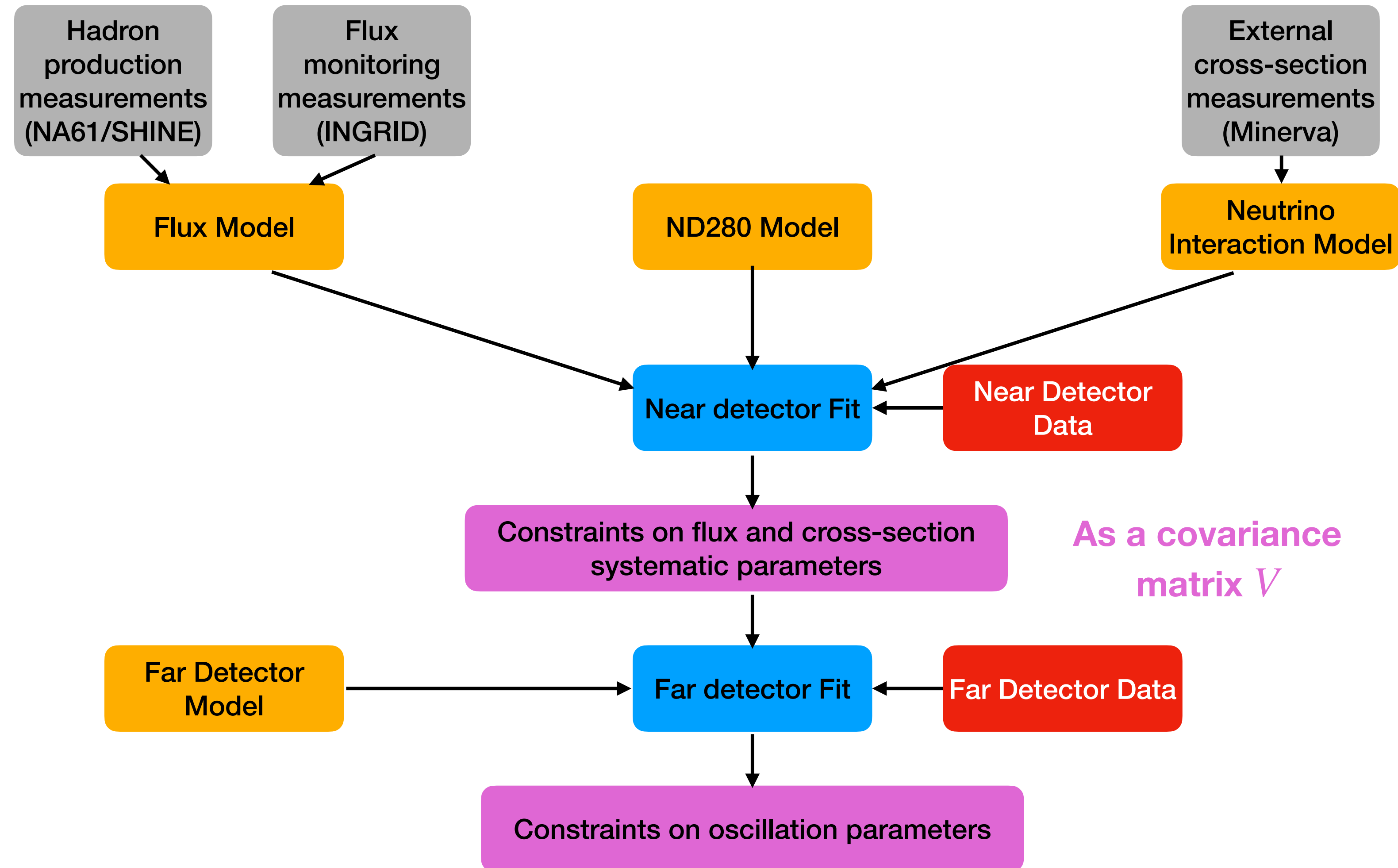

Long baseline program

Oscillation analysis

Oscillation analysis allows to extract **constraints on oscillation parameters** from event rates

Need a **reliable models of neutrino beam and interactions** to reduce systematic uncertainties

Can use **external constraints**: e.g., **NA61/SHINE** measurements

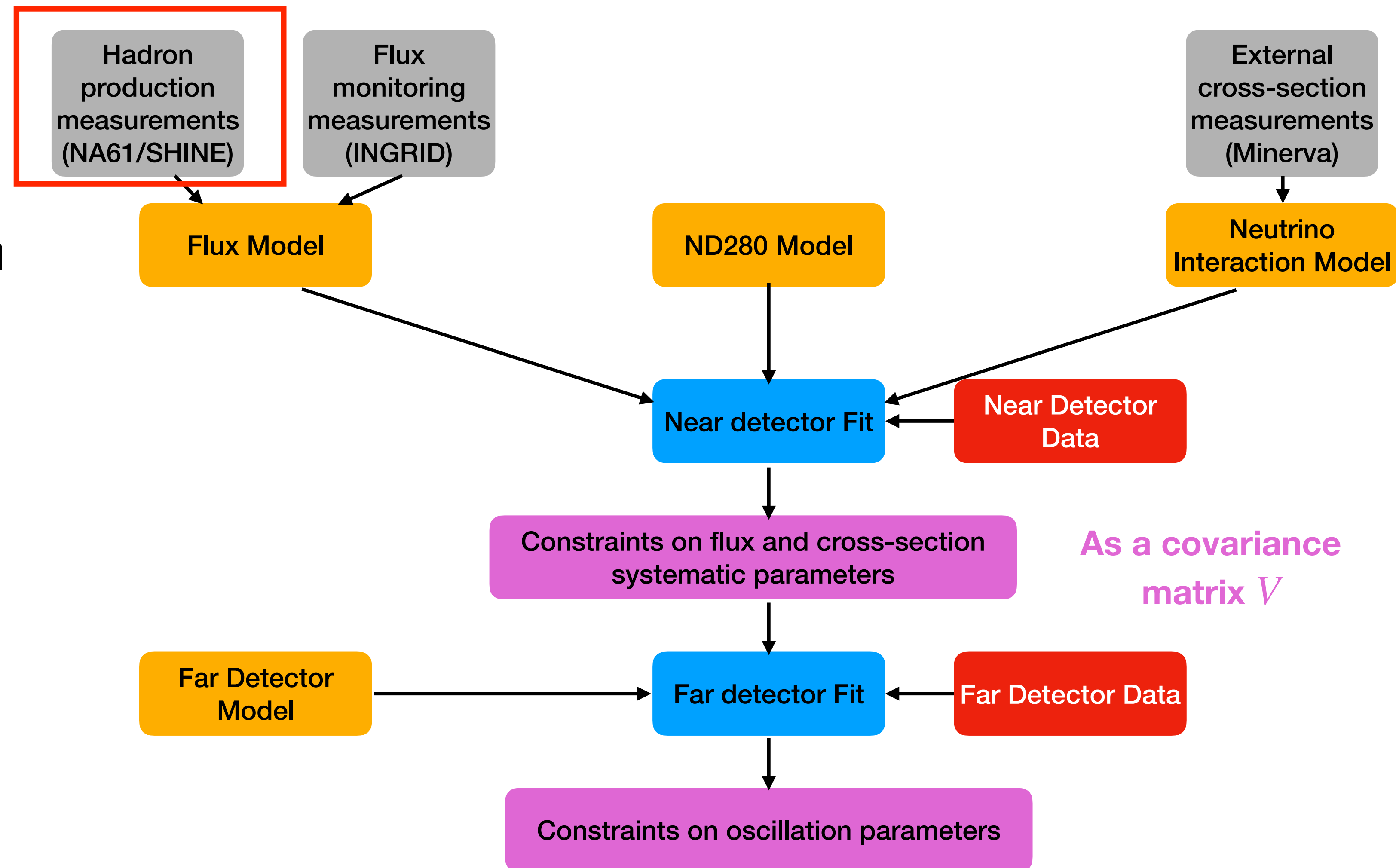

HK sensitivity Samples

- Sample **selection based on**:
 - **Horn Current**: Forward or FHC (ν_μ beam) + Reverse or RHC ($\bar{\nu}_\mu$ beam)
 - **Cherenkov ring ID**: μ^- or e^- -like
 - Number of observed **decay electrons**: 0 or 1

- Considered **5 samples**:

- FHC + RHC μ^- like (0 decay)
- FHC + RHC e^- like (0 decay)
- FHC e^- like + 1 decay e

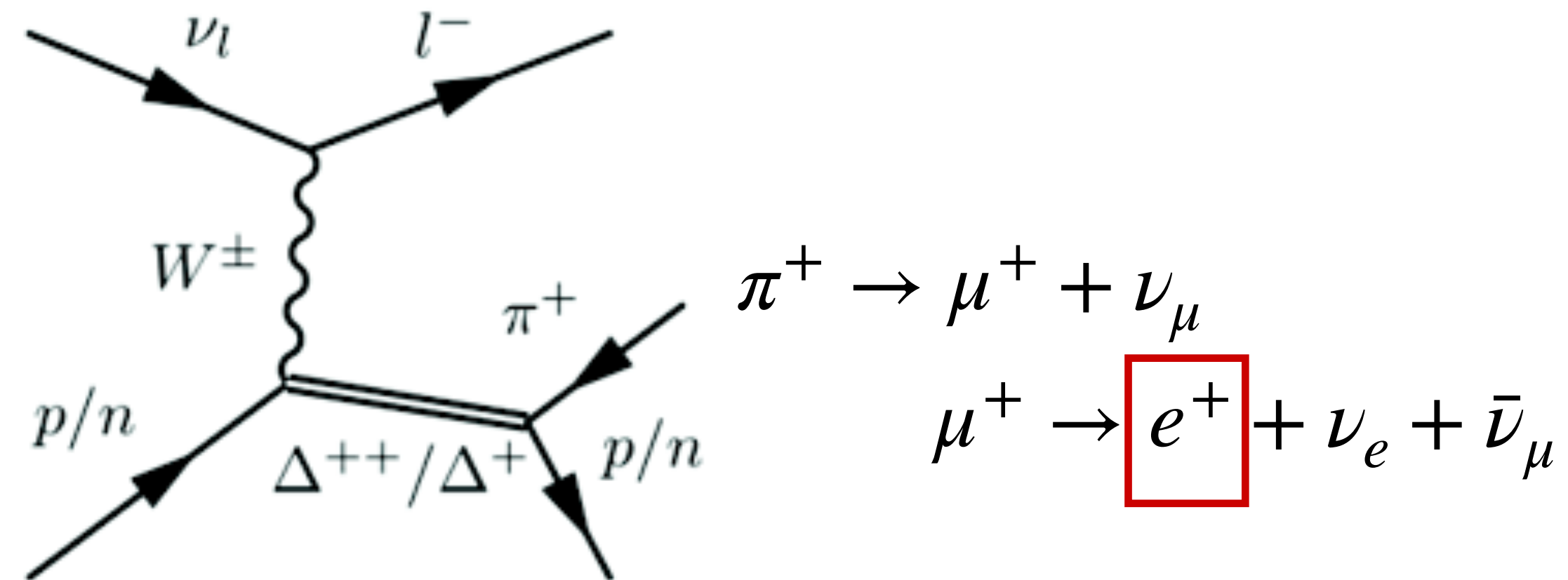

HK sensitivity Samples

- Samples are **binned** using the events kinematics:
 - ▶ *e*-like samples are binned in (p, θ)
 - ▶ μ -like samples are binned in (E_{rec}, θ)

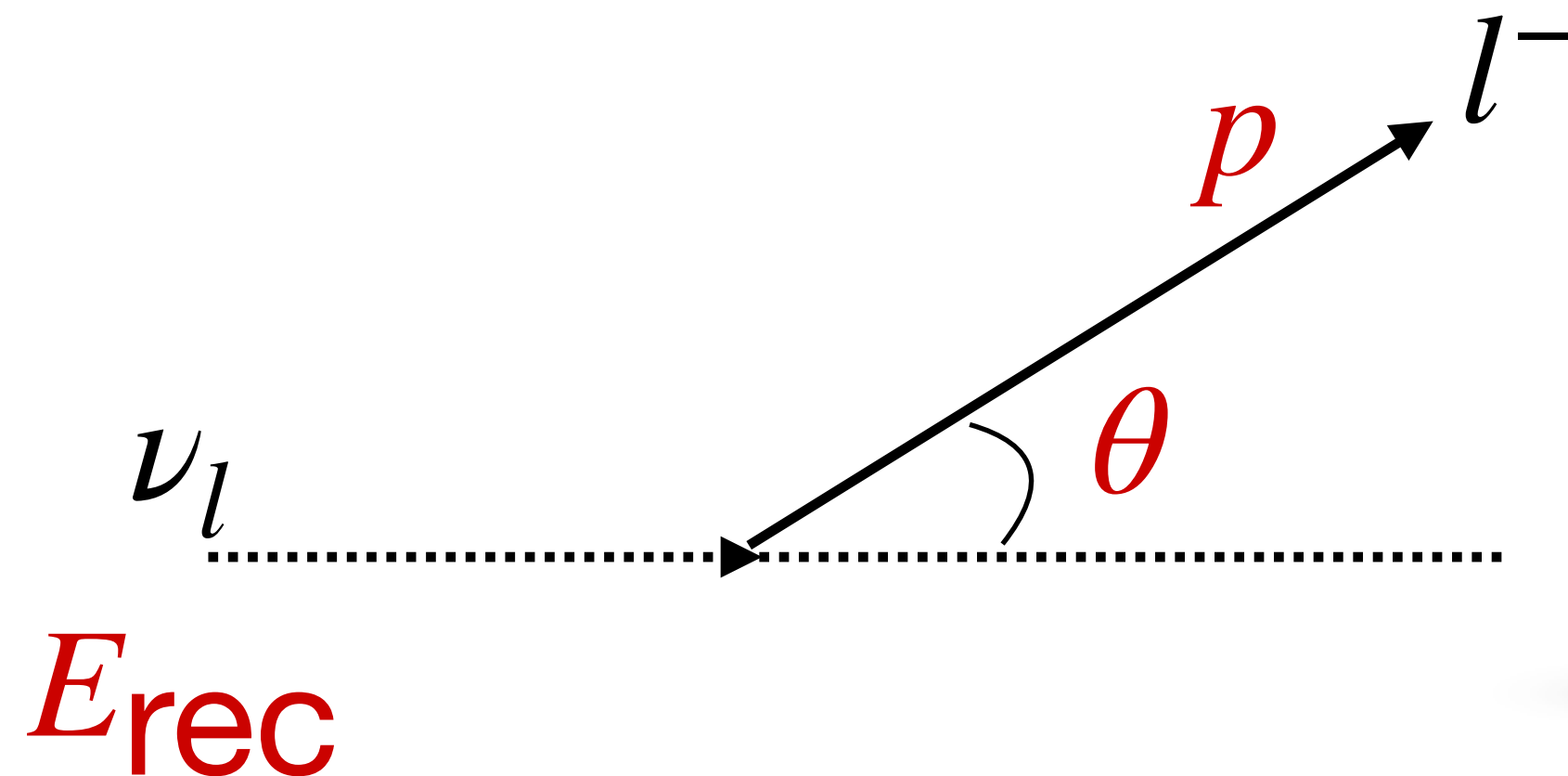

Framework's name **P-theta** comes from the *e*-like samples **binning**

Neutrino energy reconstructed from charged lepton kinematics: possible biases due to **nuclear effects** and **non CCQE** interactions

HK sensitivity

The p-theta fitter framework

Statistical term

Systematic term

$$\mathcal{L}(\{N_{s,i}^{\text{obs}}\}_{\forall s,i}, \mathbf{o}, \mathbf{f}) = \prod_{s \in \text{samples}} \prod_{i \in \text{bins}} [\text{Poisson}(N_{s,i}^{\text{obs}}, N_{s,i}^{\text{exp}}(\mathbf{o}, \mathbf{f}))] \times \mathcal{L}_{\text{syst}}(\mathbf{f})$$

Likelihood to maximise

V is the result of the ND fit

- $N_{s,i}^{\text{obs}}$: number of **observed events** in sample s bin i
- \mathbf{o} : tested values of **oscillation parameters**
- \mathbf{f} : tested values of **systematic parameters**
- $N_{s,i}^{\text{exp}}(\mathbf{o}, \mathbf{f})$: number of **expected events** in sample s bin i

$$\mathcal{L}_{\text{syst}}(\mathbf{f}) = \exp\left(-\frac{(\mathbf{f} - \mathbf{f}_0)^T V^{-1} (\mathbf{f} - \mathbf{f}_0)}{2}\right)$$

Penalty term with \mathbf{f}_0 the prior value of systematic parameters and V the prior covariance between systematic parameters

HK sensitivity

The p-theta fitter framework



Fit consists in finding $\chi^2(\Theta) = \min_{\mathbf{y}} (-2 \ln \mathcal{L}(\Theta, \mathbf{y}))$

- Θ : **parameter of interest** = $\sin^2 \theta_{23}$, $|\Delta m_{32}^2|$ and δ_{CP} **Today's focus!**
- \mathbf{y} : **nuisance parameters** = others oscillation parameters + systematic parameters
- Minimisation performed by Migrad algorithm of **Minuit2**
- In practice, need to constrain the **MO (fit either in NO or IO)** and the θ_{23} **octant**: at least **4 fits** necessary, choose the **lowest χ^2**

HK sensitivity

P-theta fitter: marginalisation vs profiling

- T2K OA is based on a marginal likelihood : $\mathcal{L}(\Theta) = \frac{1}{N_{\text{throws}}} \sum_{i=1}^{N_{\text{throws}}} \mathcal{L}(\Theta, y_i)$
- Usually offers a better representation of the impact of non Gaussian nuisance parameters
- But it is positively biased with $B = \sigma(\mathcal{L})^2 / N_{\text{throws}}$. The number of throws needed also grows with the statistics considered: the fitting becomes very long for HK statistics!
- Methods are being considered to increase the speed of marginal likelihood fitting (importance sampling)

HK sensitivity

P-theta fitter: marginalisation vs profiling

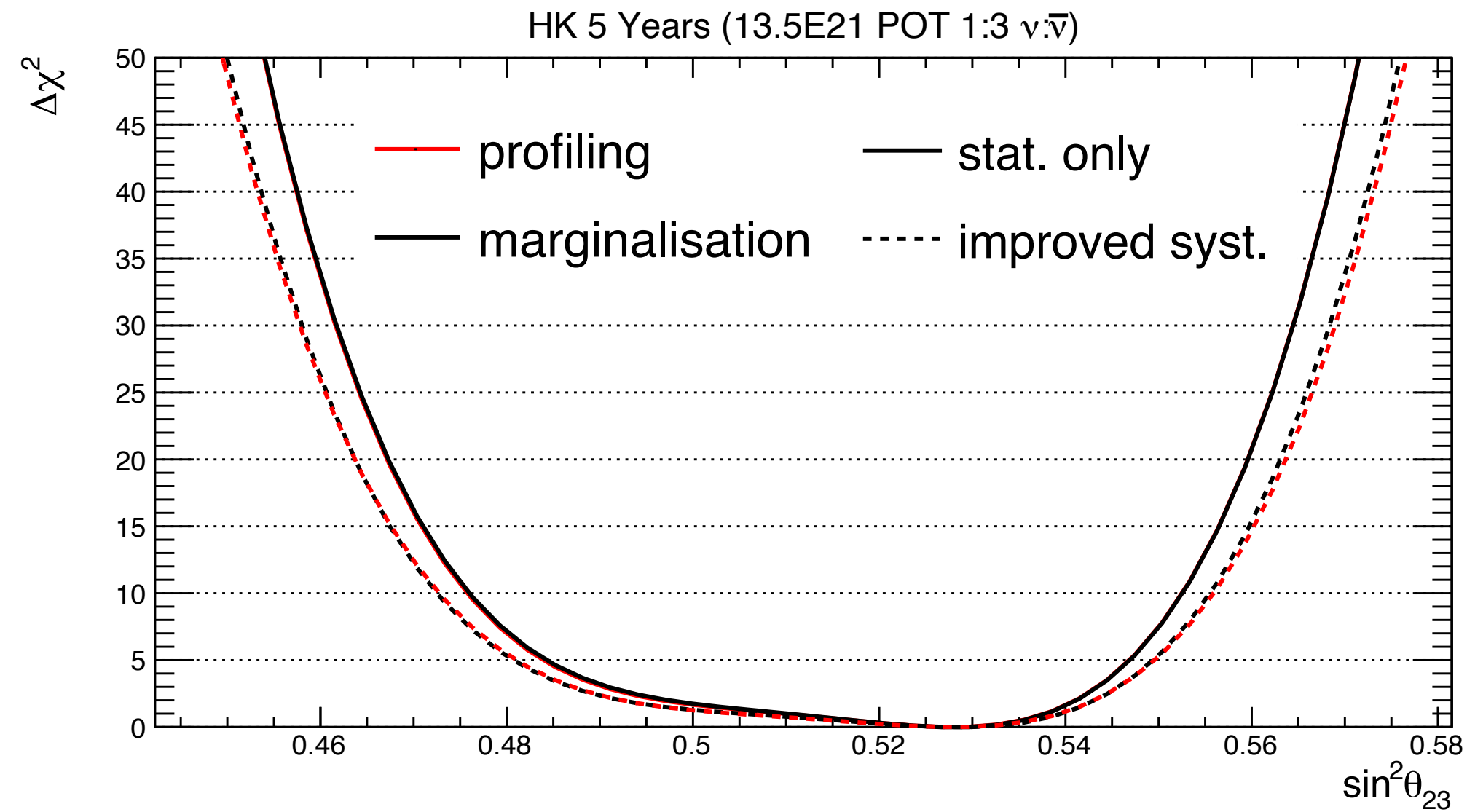

$$N_{\text{throws}} = 10^6$$

- Difference increases with systematic effects
- Generally more optimistic estimation with marginal likelihood

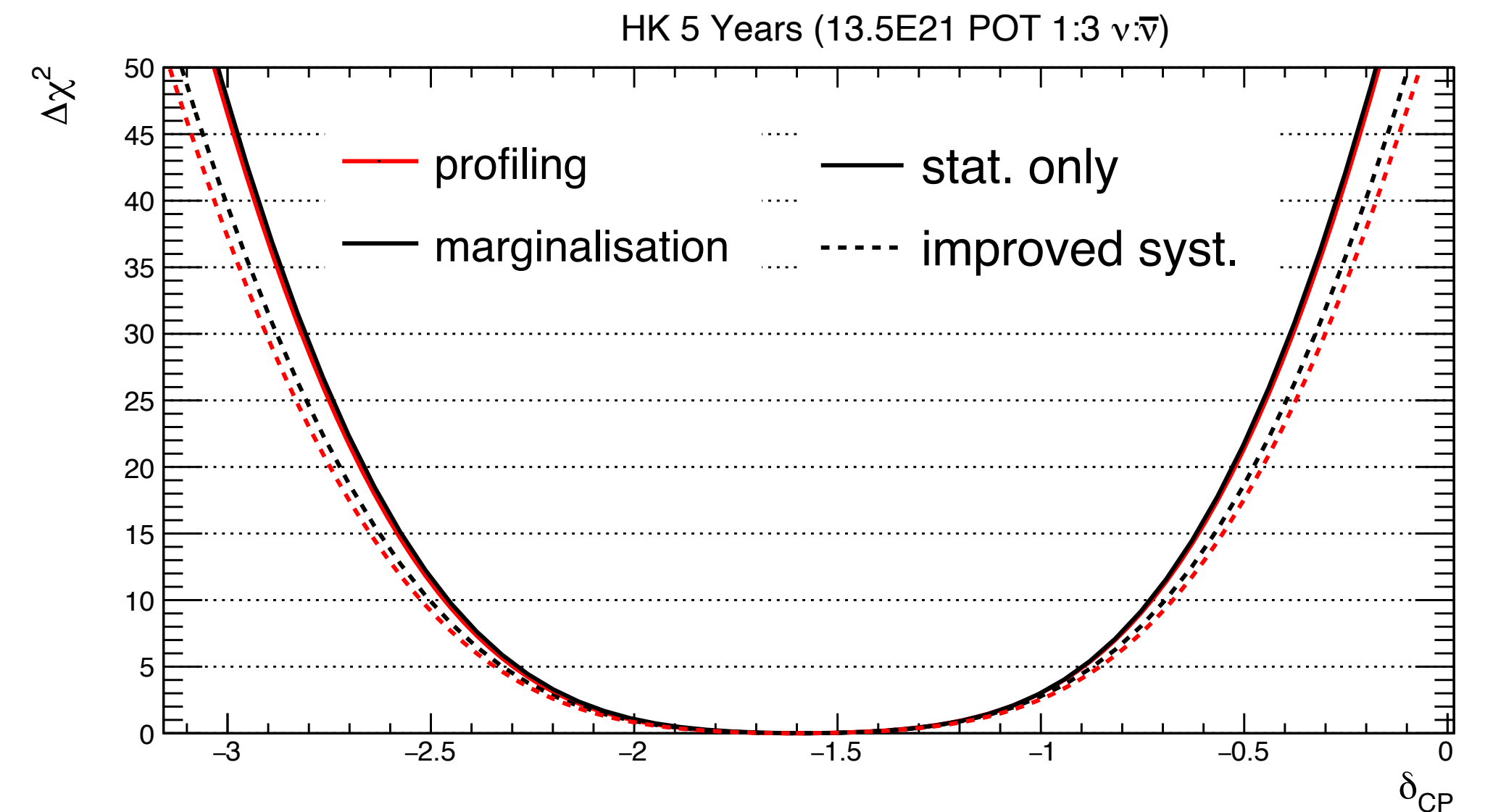
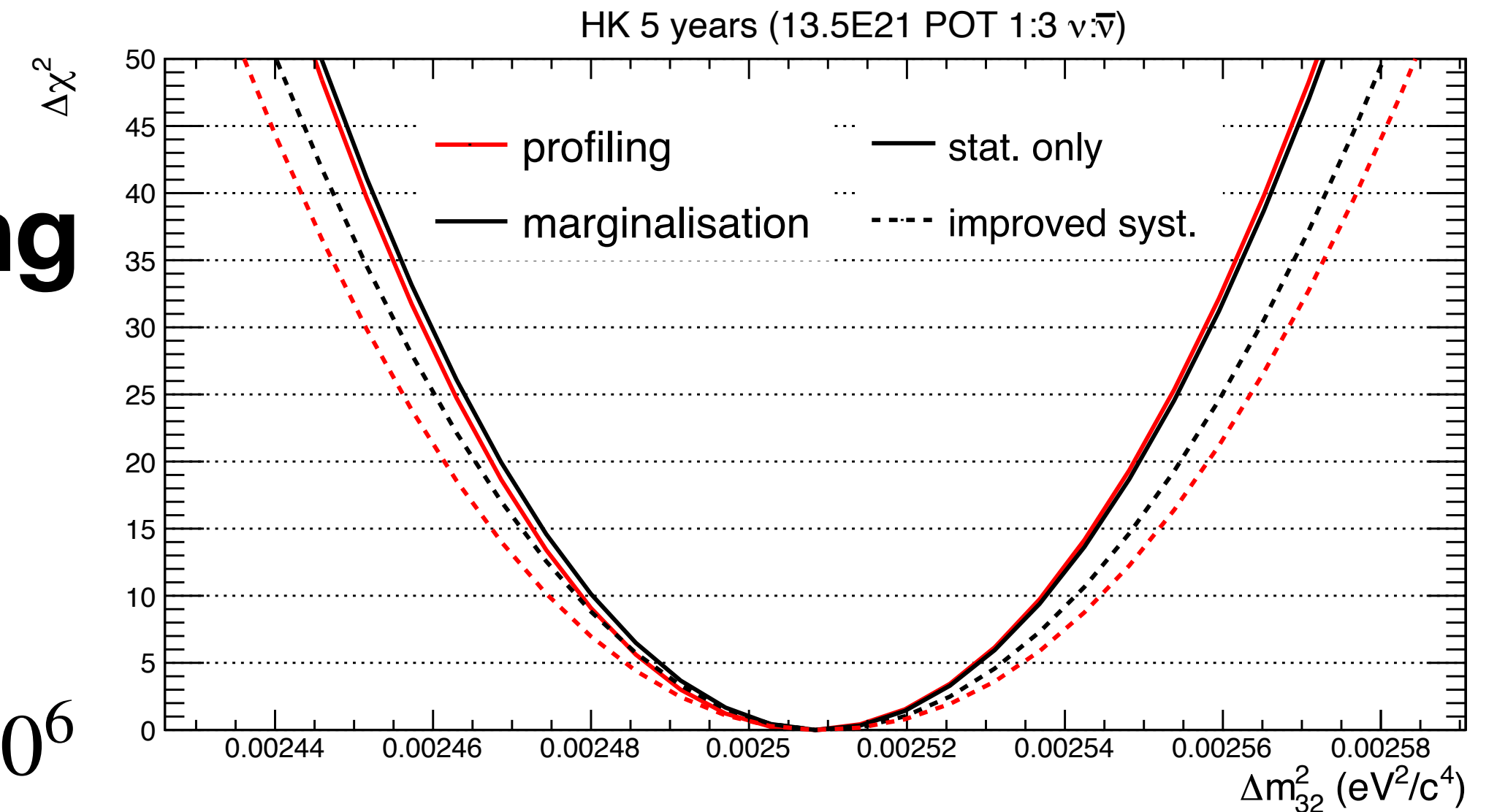

HK sensitivity

Systematics model

T2K 2020 Error source	1 ring μ -like		1 ring e-like			
	ν -mode	$\bar{\nu}$ -mode	ν -mode + 0 decay	$\bar{\nu}$ -mode + 0 decay	ν -mode + 1 decay	$\nu/\bar{\nu}$ -mode + 0 decay
ND constrained Flux + Cross section	2,1 %	3,4 %	3,6 %	4,3 %	4,9 %	4,4 %
Not ND constrained Cross-section	0,5 %	2,6 %	3,0 %	3,7 %	2,7 %	4,1 %
Detector	2,1 %	1,9 %	3,1 %	3,9 %	13,2 %	1,1 %
All systematics	3,0 %	4,0 %	4,7 %	5,9 %	14,1 %	4,6 %

Uncertainty on predicted event rates with T2K 2020 level of systematics

Error source	1 ring μ -like		1 ring e-like			
	ν -mode	$\bar{\nu}$ -mode	ν -mode + 0 decay	$\bar{\nu}$ -mode + 0 decay	ν -mode + 1 decay	$\nu/\bar{\nu}$ -mode + 0 decay
ND constrained Flux + Cross section	0,9 %	0,9 %	1,8 %	1,6 %	1,8 %	1,9 %
Not ND constrained Cross-section	0,4 %	0,4 %	1,6 %	1,4 %	1,6 %	1,9 %
Detector	0,8 %	0,7 %	1,1 %	1,5 %	4,9 %	0,4 %
All systematics	1,2 %	1,1 %	2,1 %	2,2 %	5,2 %	2,0 %

Uncertainty on predicted event rates with the HK Improved level of systematics



HK sensitivity

The p-theta fitter framework

Run plan $\nu : \bar{\nu} = 1 : 3$ chosen to compensate for $\bar{\nu}$ lower cross section

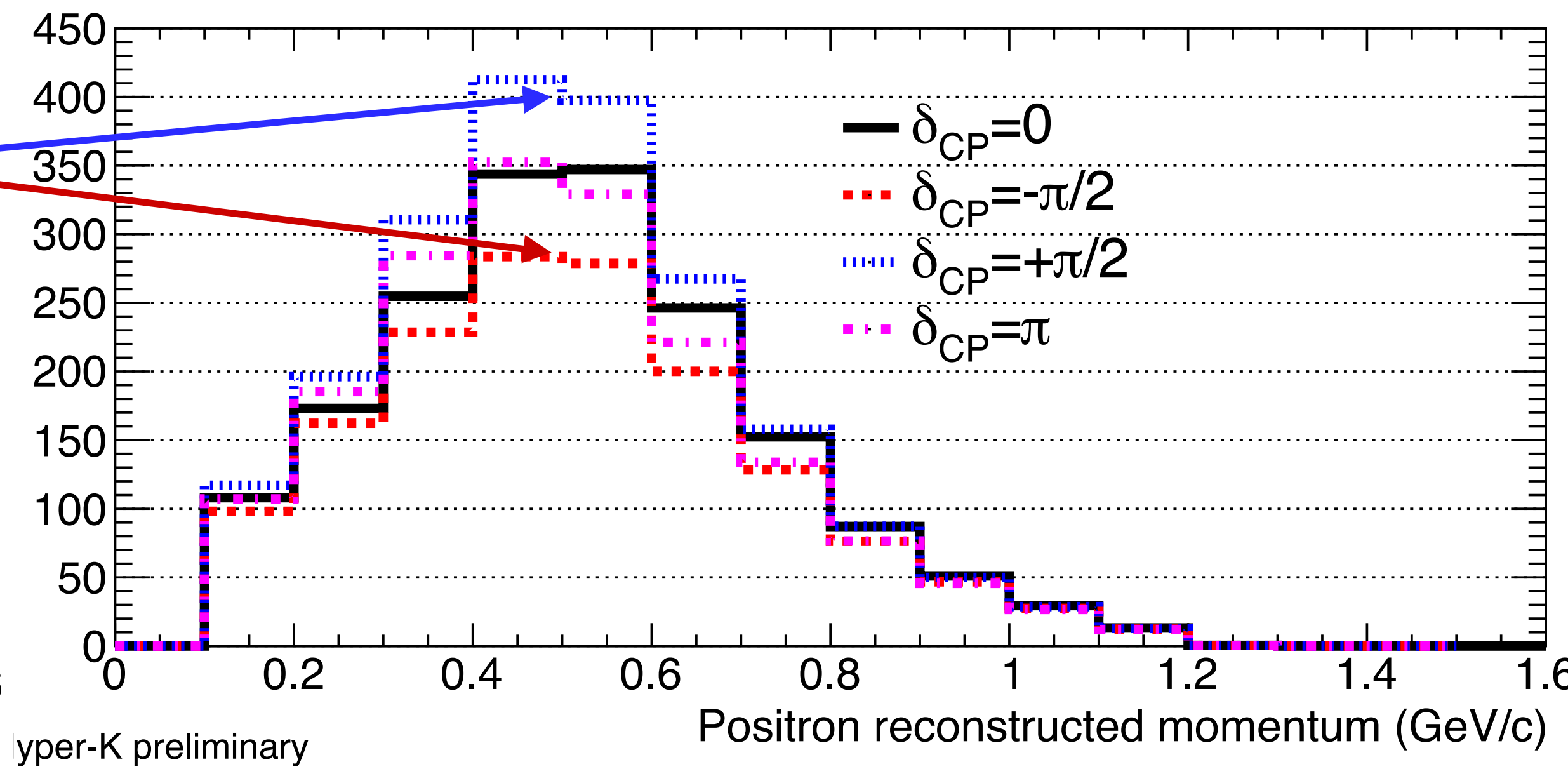
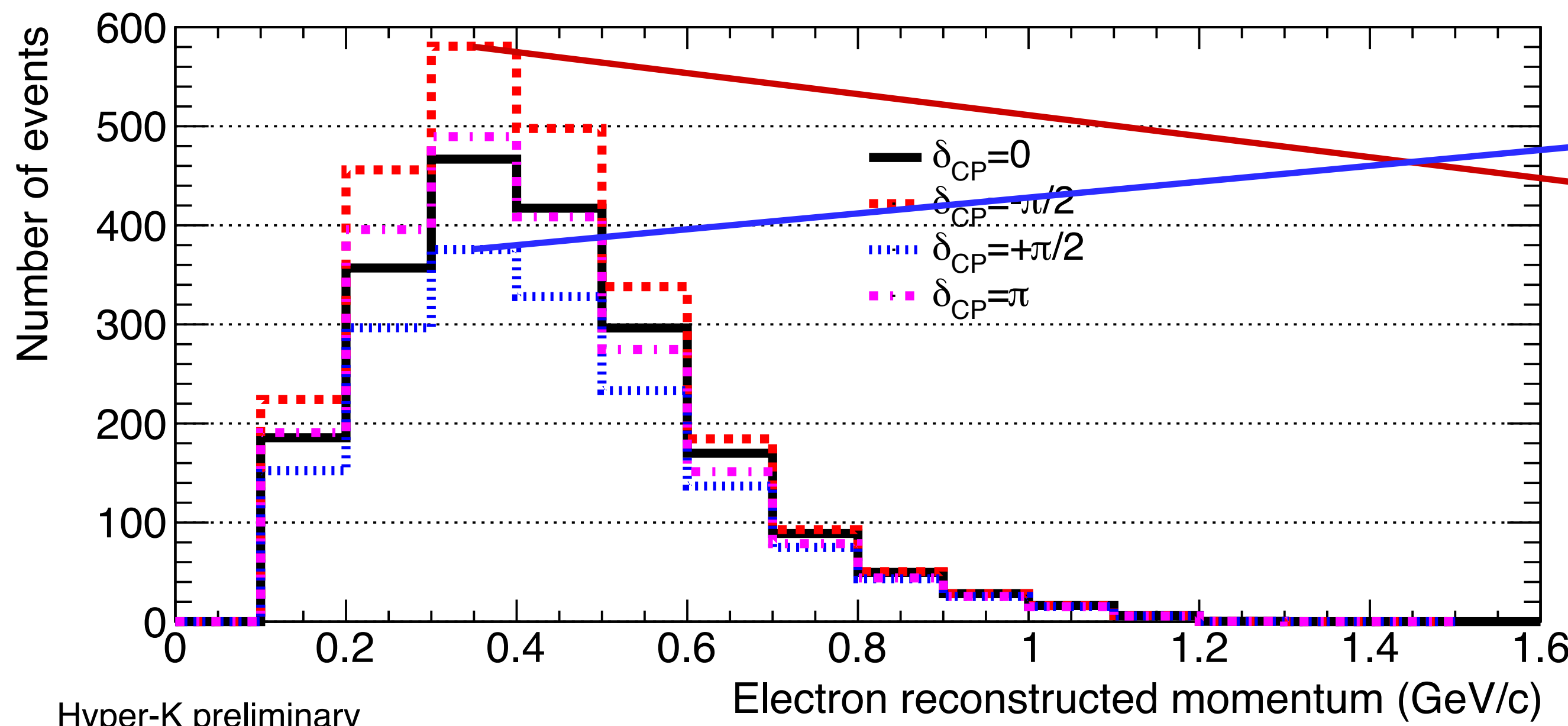

Any **systematic** that **mimic** this effect can **limit the sensitivity to CP violation**: e.g., $\sigma(\nu_e)/\sigma(\bar{\nu}_e)$

HK sensitivity

Event rates

Run plan $\nu : \bar{\nu} = 1 : 3$ chosen to compensate for $\bar{\nu}$ lower cross section

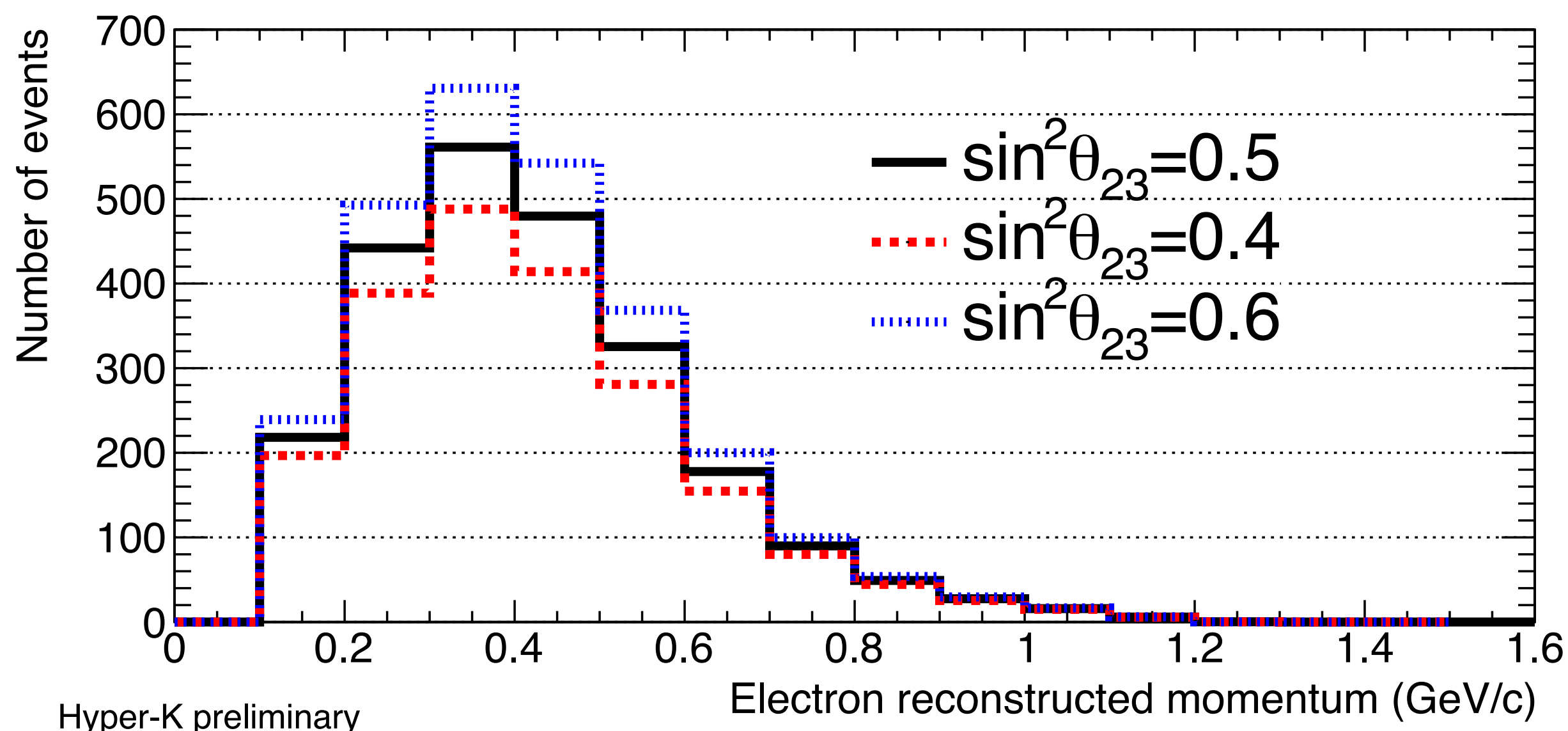

FHC e-like

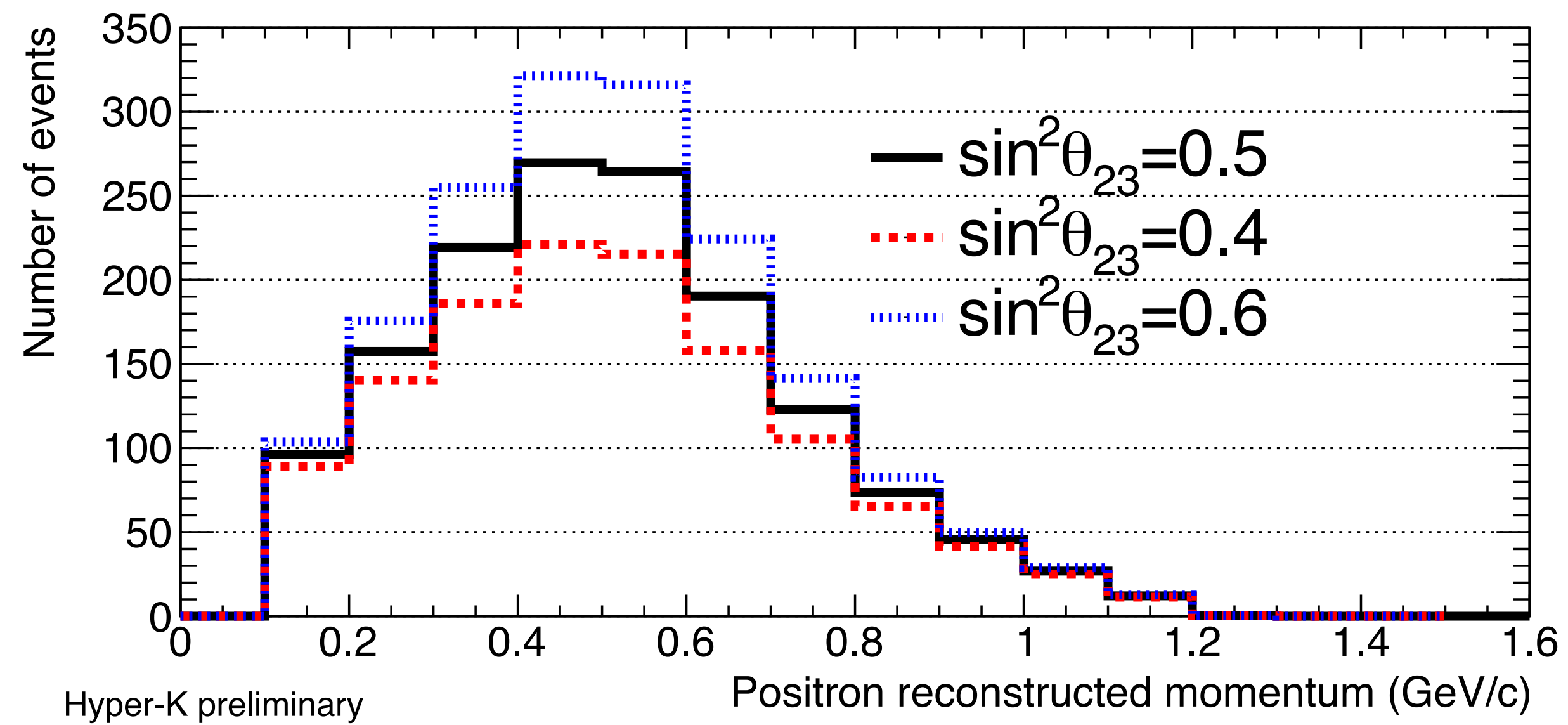

RHC e-like

$\sin^2\theta_{23}$ has a **symmetric** impact on event rates in FHC and RHC: **e-like** event rates **increases with**

$\sin^2\theta_{23}$.

HK sensitivity

Event rates

Run plan $\nu : \bar{\nu} = 1 : 3$ chosen to compensate for $\bar{\nu}$ lower cross section

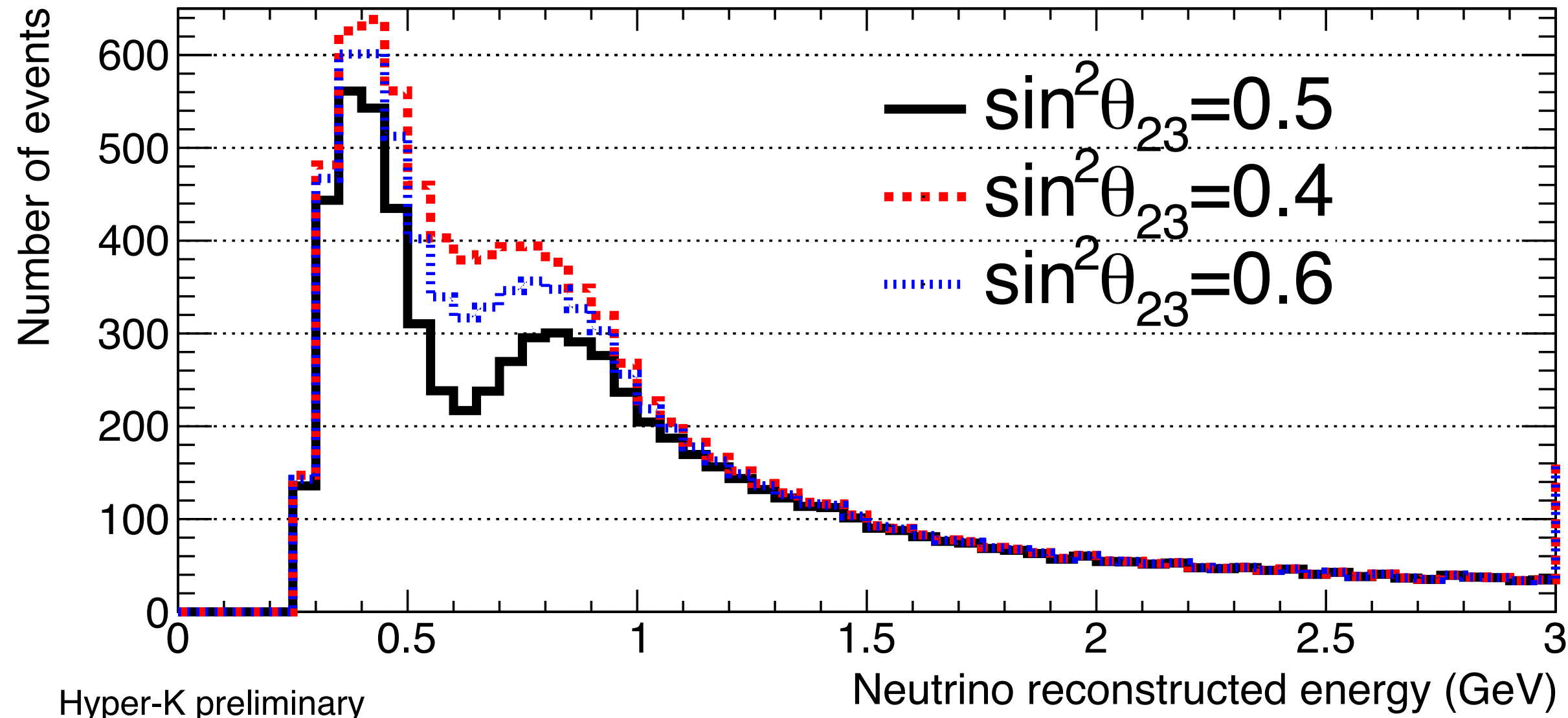

FHC mu-like

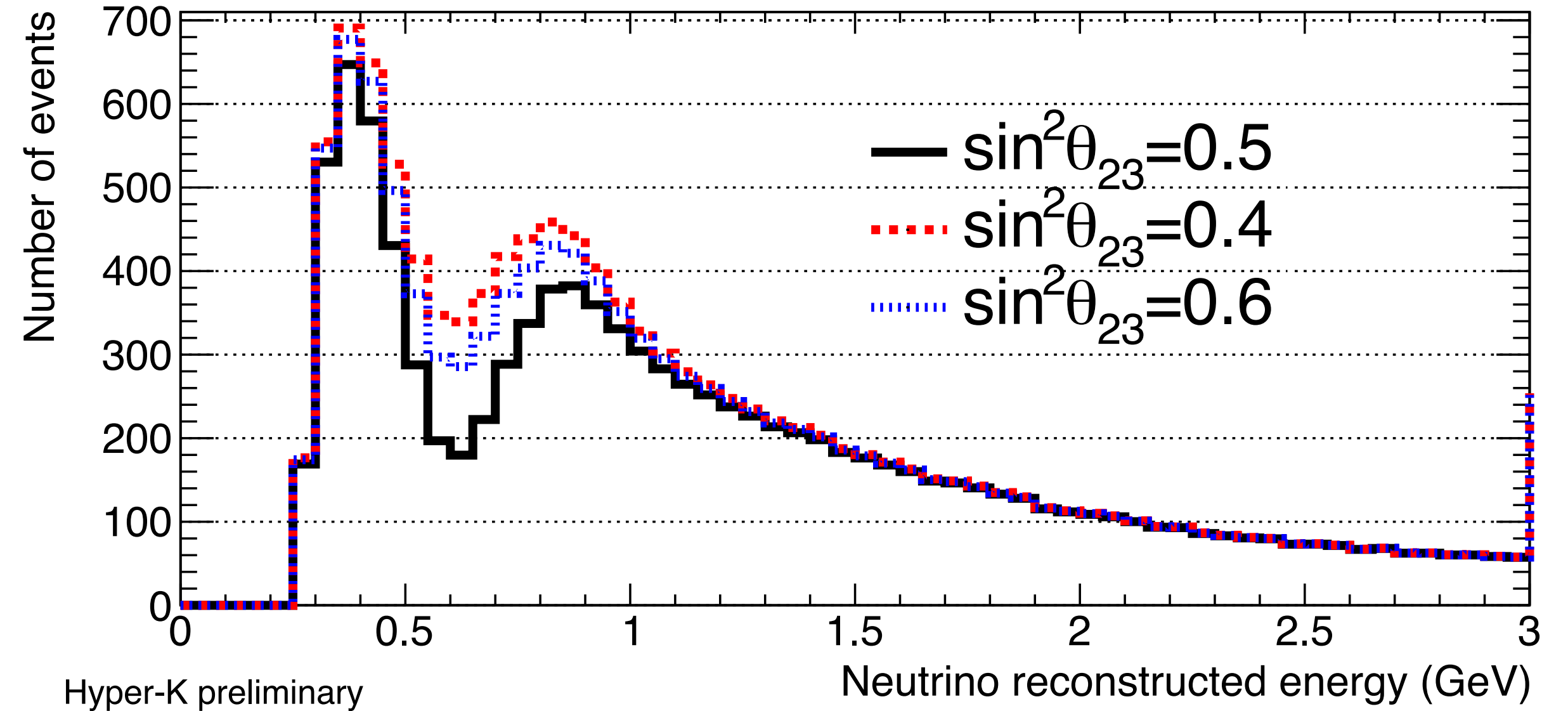

RHC mu-like

$\sin^2\theta_{23}$ has a **symmetric** impact on event rates in FHC and RHC: **mu-like** event rates **minimised**
at $\sin^2\theta_{23} \approx 0.511$.

HK sensitivity

Event rates

Run plan $\nu : \bar{\nu} = 1 : 3$ chosen to compensate for $\bar{\nu}$ lower cross section

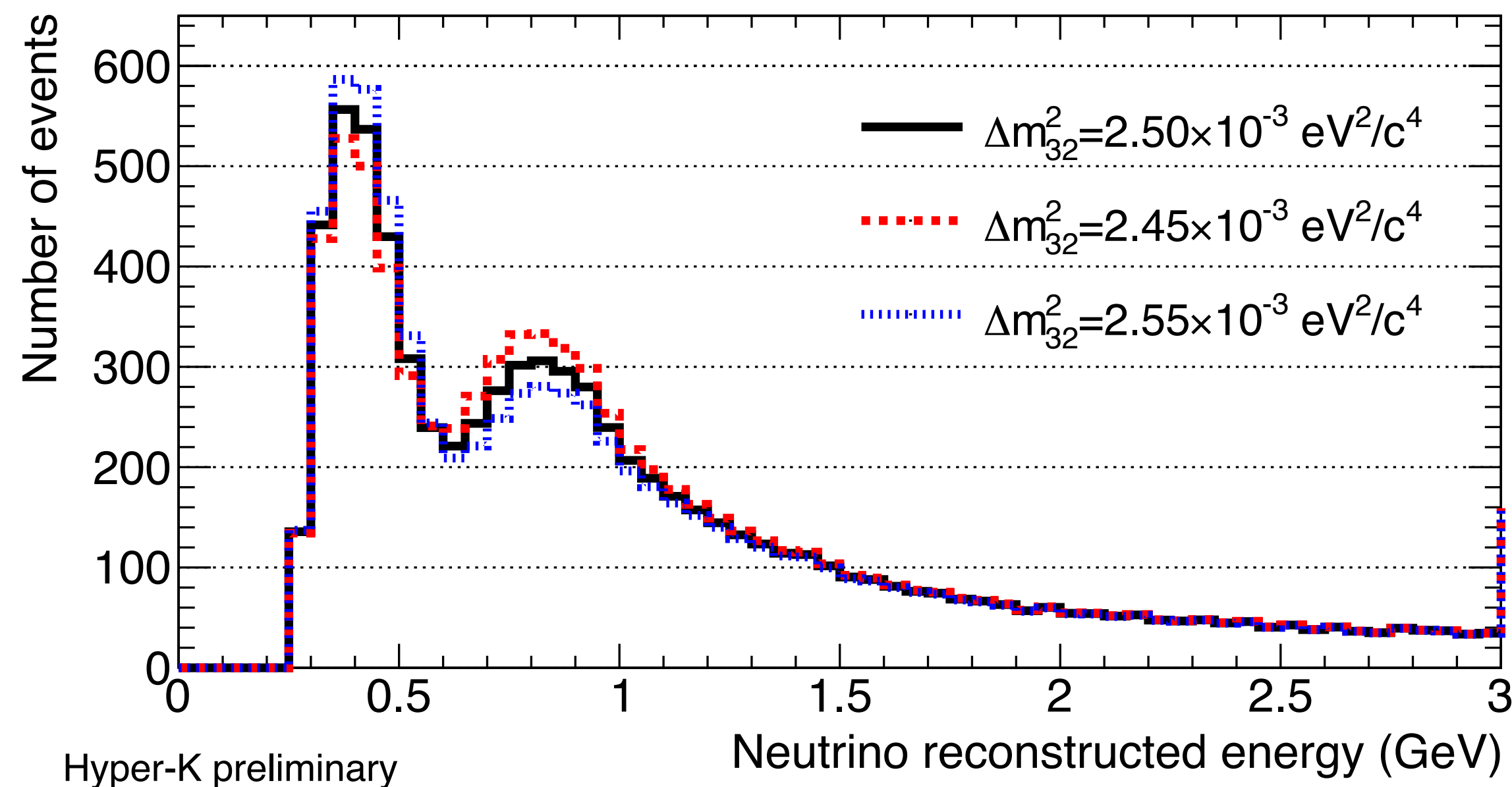

FHC mu-like

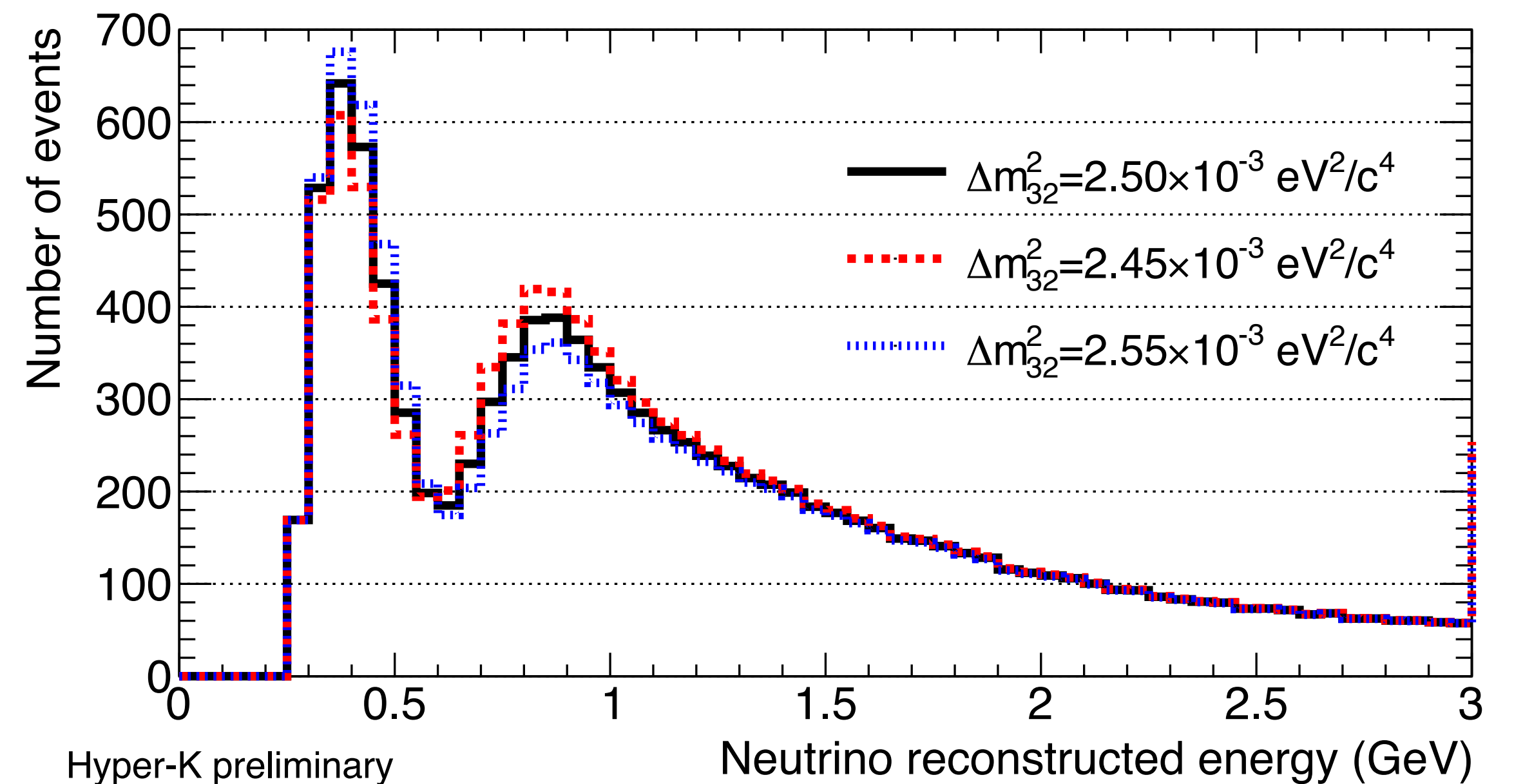

FHC mu-like

$|\Delta m_{32}^2|$ influences **position and value** of **minimum mu-like** event rates (maximal disappearance).



HK sensitivity

Precision measurements

- $\sigma(\nu_e)/\sigma(\bar{\nu}_e)$ not measured in T2K, use theoretical **constraint of 4.9%** (blue & green)
- **HK** plans to **measure** $\sigma(\nu_e)/\sigma(\bar{\nu}_e)$ with NDs: **goal constraint is 2.7%** (red)
- **Big impact** of $\sigma(\nu_e)/\sigma(\bar{\nu}_e)$ if $\sin \delta_{CP} \approx 0$
- **Other systematic** effects become **important for** $|\sin \delta_{CP}| \approx 1$ (see studies in back-up)

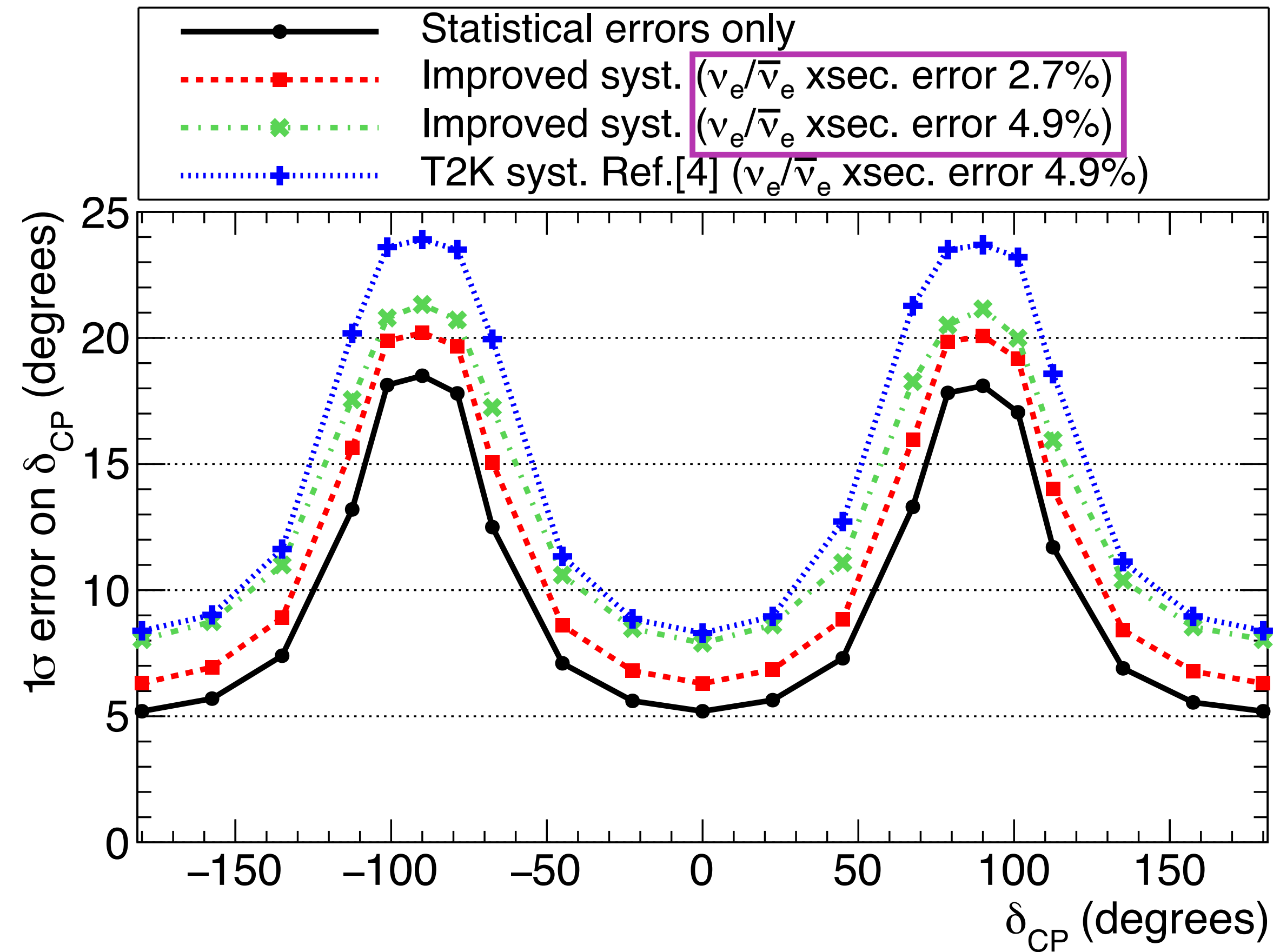

1σ resolution on the measurement of δ_{CP} after 10 years
 Estimated from width of χ^2 distribution at $\chi^2 = 1$

HK sensitivity

Precision measurements

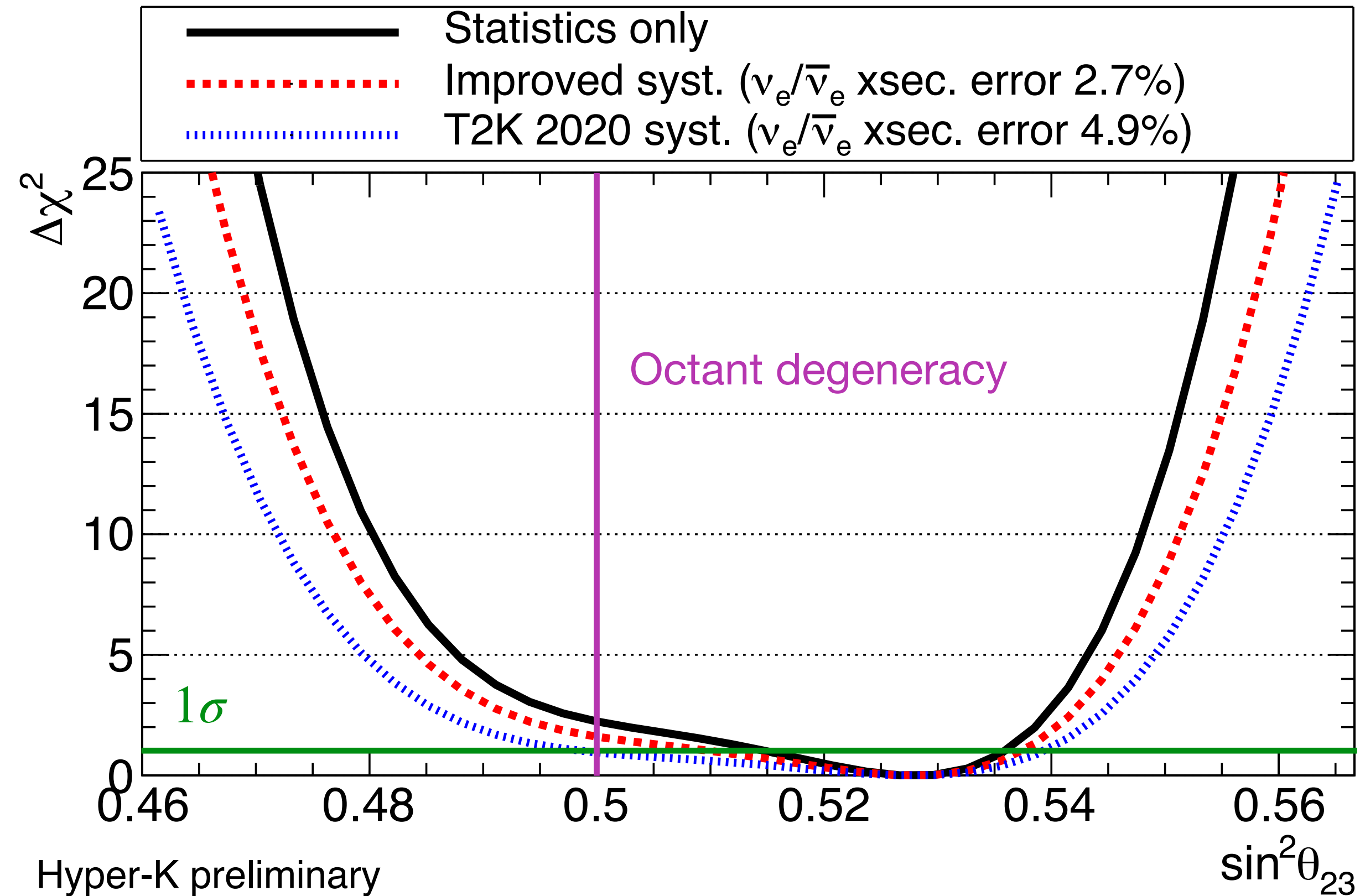

Hyper-K preliminary

True normal ordering (known), 10 years (2.7×10^{22} POT 1:3 $\nu:\bar{\nu}$)

$\sin^2\theta_{13}=0.0218 \pm 0.0007$, $\sin^2\theta_{23}=0.528$, $\Delta m_{32}^2=2.509 \times 10^{-3} \text{eV}^2/c^4$, $\delta_{CP}=-1.601$

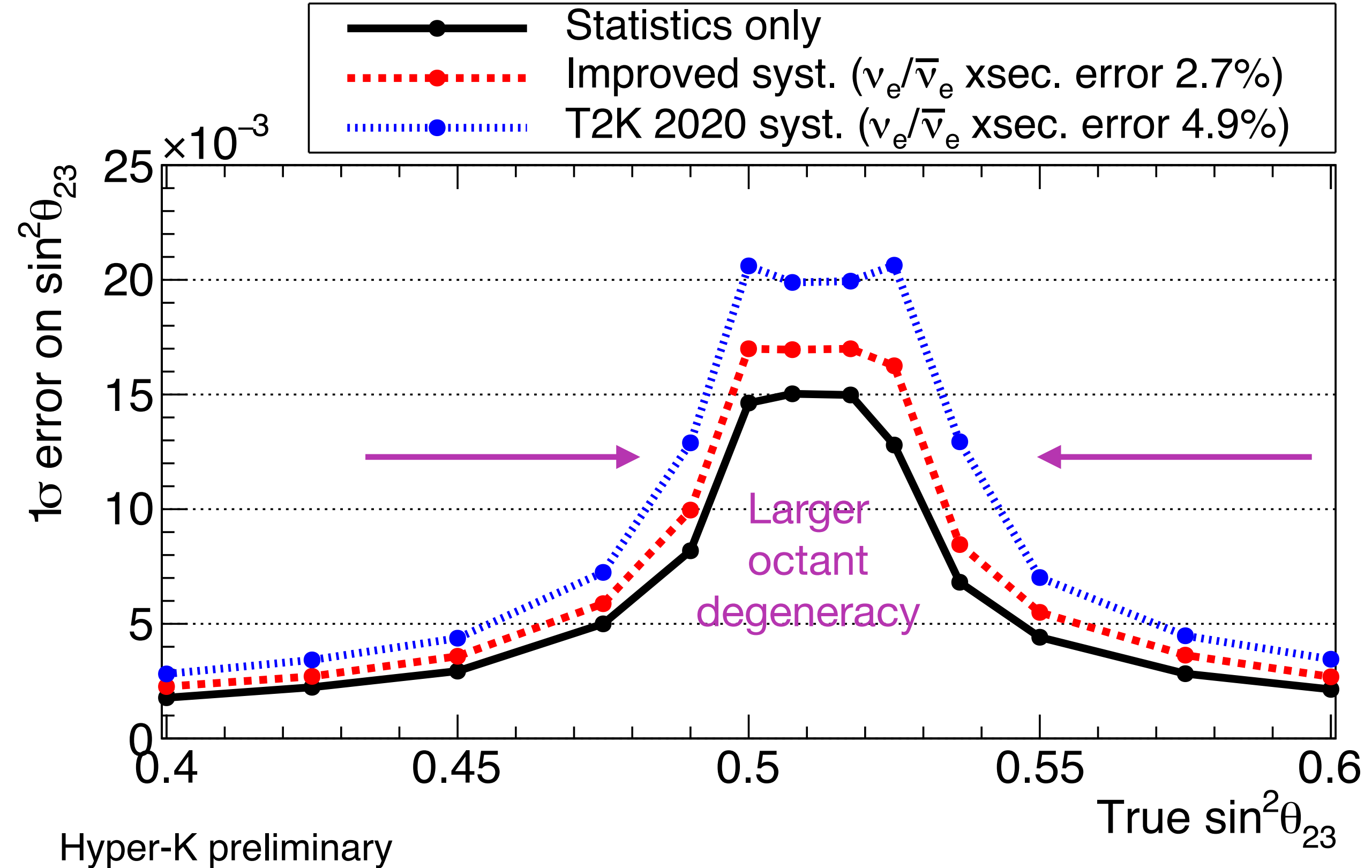

Hyper-K preliminary

True normal ordering (known)

$\sin^2\theta_{13}=0.0218 \pm 0.0007$, $\Delta m_{32}^2=2.509 \times 10^{-3} \text{eV}^2/c^4$, $\delta_{CP}=-1.601$

HK sensitivity

Precision measurements

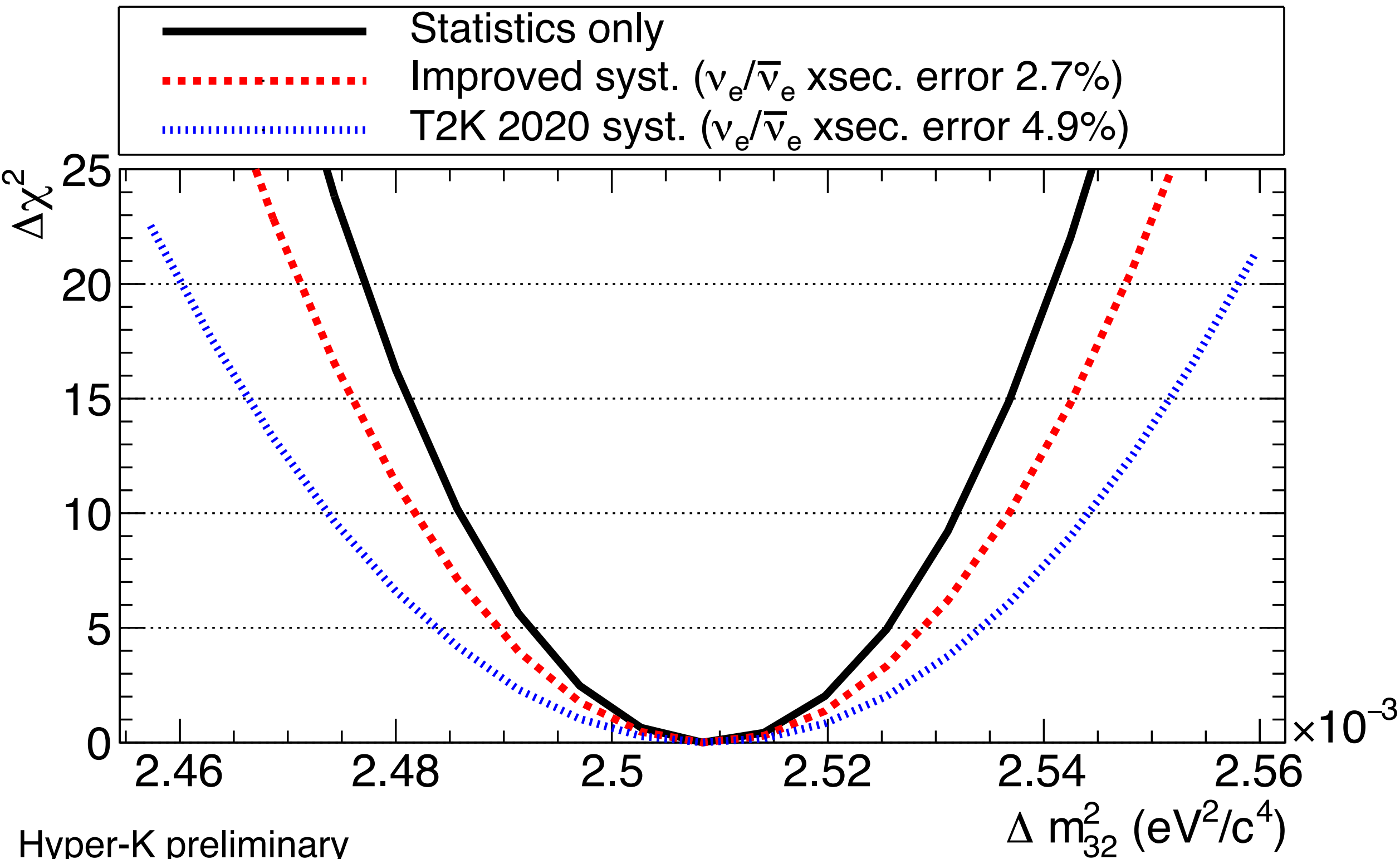

Hyper-K preliminary

True normal ordering (known), 10 years (2.7×10^{22} POT 1:3 $\nu:\bar{\nu}$)

$\sin^2\theta_{13}=0.0218 \pm 0.0007$, $\sin^2\theta_{23}=0.528$, $\Delta m_{32}^2=2.509 \times 10^{-3} \text{ eV}^2/\text{c}^4$, $\delta_{\text{CP}}=-1.601$

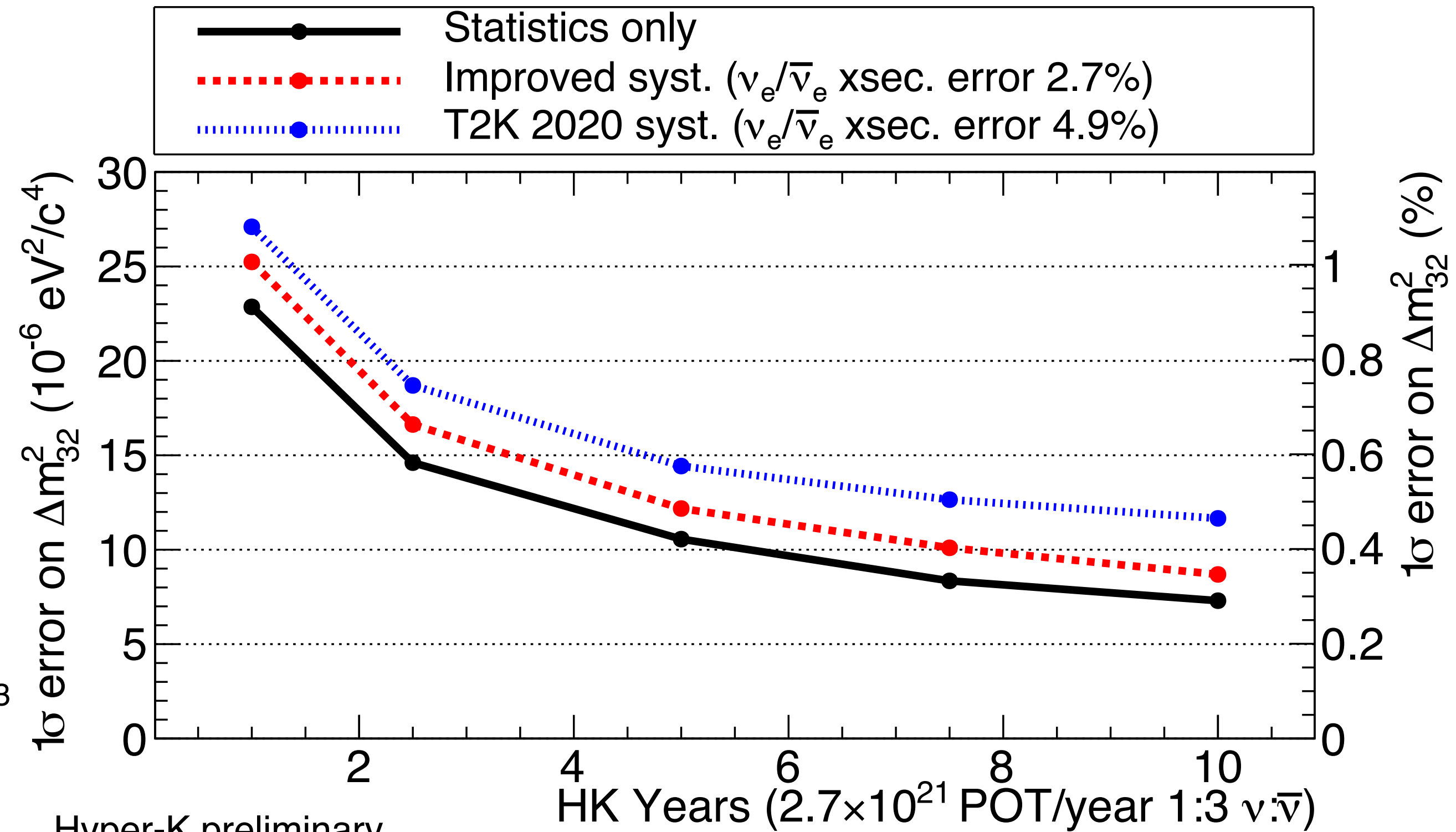

Hyper-K preliminary

True normal ordering (known)

$\sin^2\theta_{13}=0.0218 \pm 0.0007$, $\sin^2\theta_{23}=0.528$, $\Delta m_{32}^2=2.509 \times 10^{-3} \text{ eV}^2/\text{c}^4$, $\delta_{\text{CP}}=-1.601$

HK sensitivity

Precision measurements

- **Resolution** to δ_{CP} primarily comes from the **term proportional to $\sin \delta_{CP}$** in $P(\nu_\mu \rightarrow \nu_e)$, CP-odd term
- The **gradient** of this term is **maximised at $|\cos \delta_{CP}| = 1$**
- Hence **better resolution if $\delta_{CP} = 0 [\pi]$** and lower resolution if $\delta_{CP} = \pi/2 [\pi]$

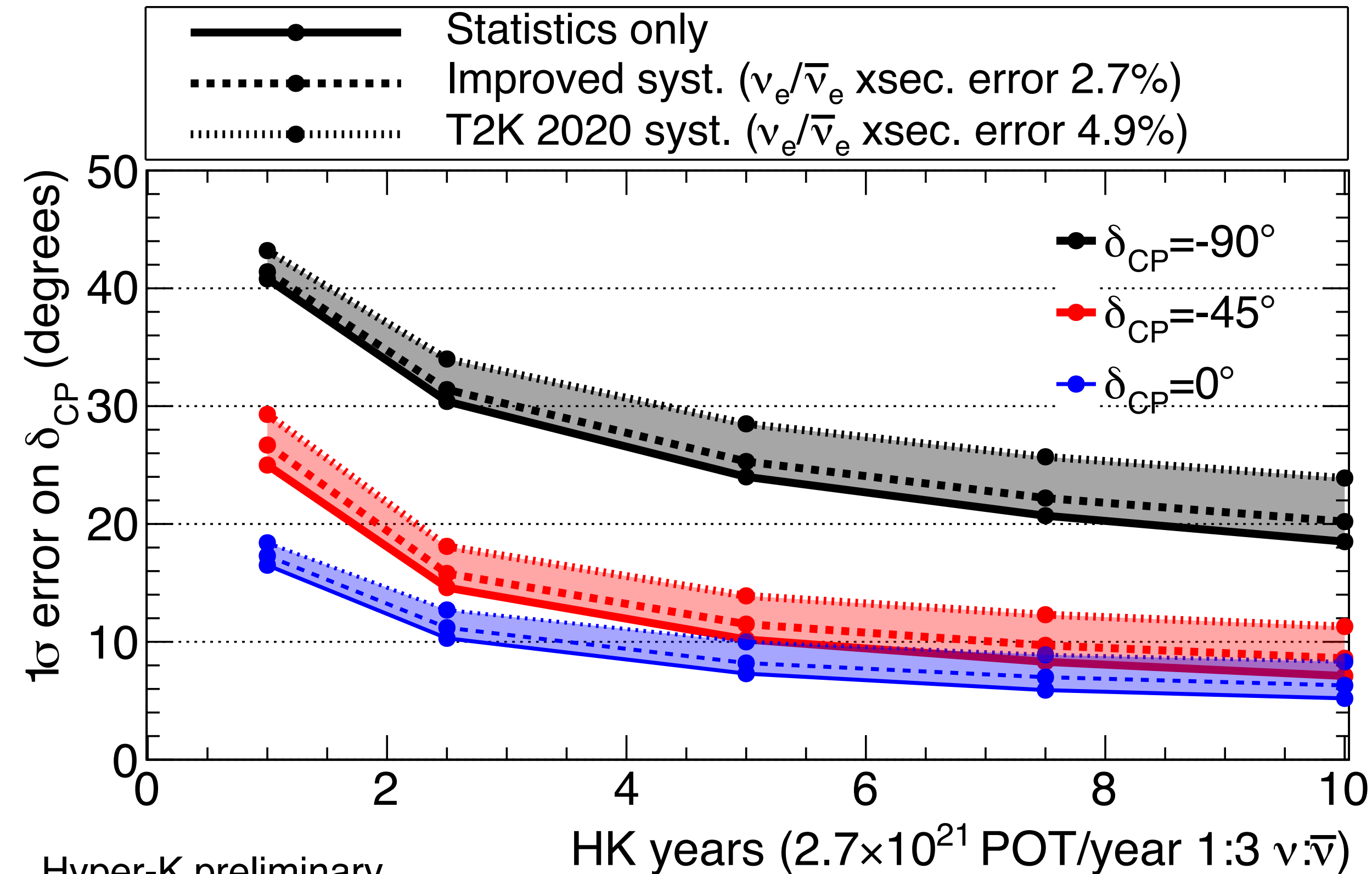

Hyper-K preliminary

True normal ordering (known)

$\sin^2 \theta_{13} = 0.0218 \pm 0.0007$, $\sin^2 \theta_{23} = 0.528$, $\Delta m_{32}^2 = 2.509 \times 10^{-3} \text{ eV}^2/c^4$

HK sensitivity

Precision measurements

$$\sigma_{\text{tot}}^2 = \sigma_{\text{stat}}^2 + \sigma_{\text{syst}}^2$$

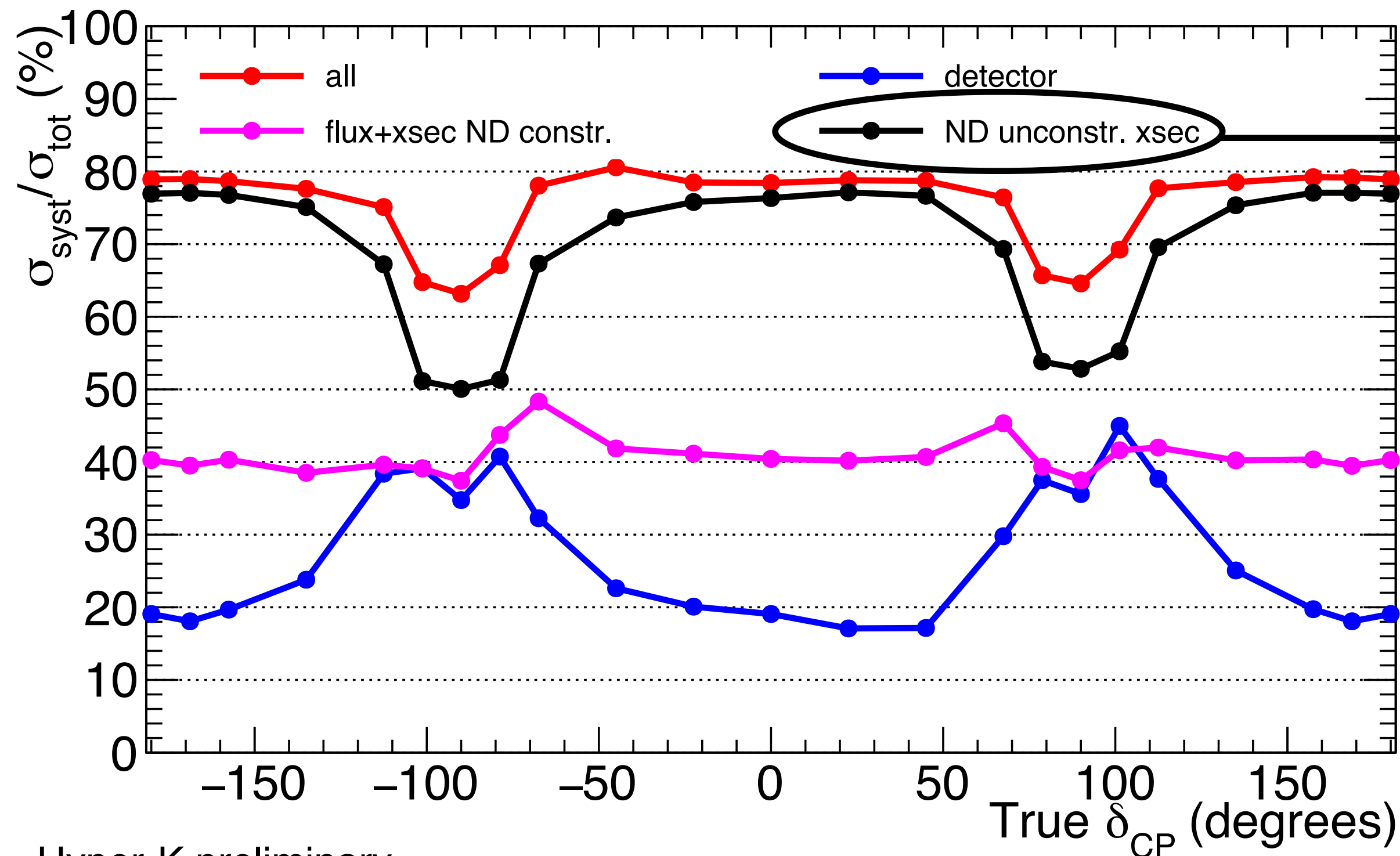

Hyper-K preliminary
 True normal ordering (known)
 $\sin^2\theta_{13}=0.0218\pm 0.0007$ $\sin^2\theta_{23}=0.528$ $\Delta m_{32}^2=2.509\text{E-}3\text{eV}^2/c^4$

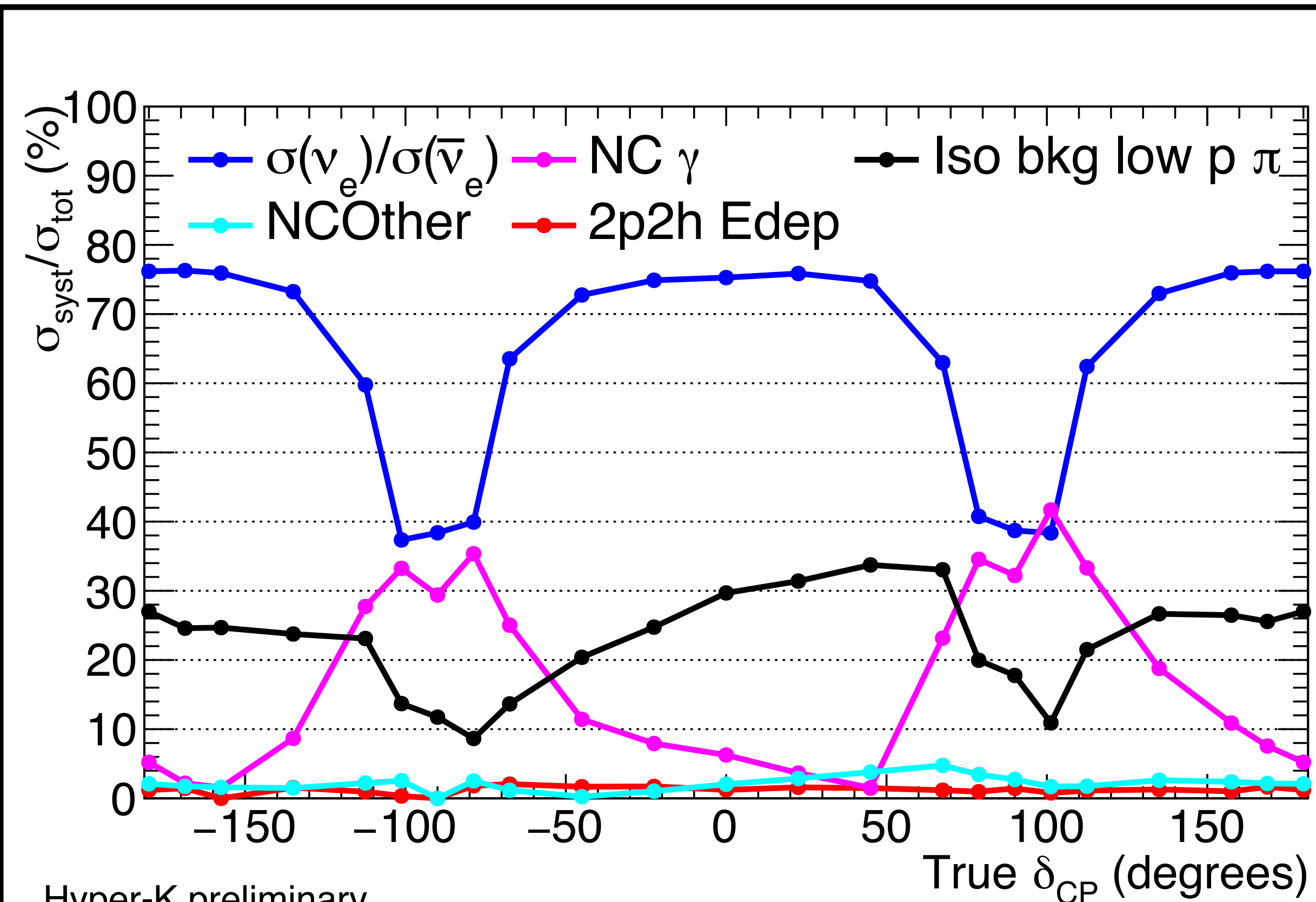

Hyper-K preliminary
 True normal ordering (known)
 $\sin^2\theta_{13}=0.0218\pm 0.0007$ $\sin^2\theta_{23}=0.528$ $\Delta m_{32}^2=2.509\text{E-}3\text{eV}^2/c^4$

T2K 2020 systematics

HK sensitivity

CP violation discovery

- Now Improved systematics but with various assumed uncertainty on $\sigma(\nu_e)/\sigma(\bar{\nu}_e)$
- This systematic impacts the 5σ discovery potential of CP violation, especially for low CP violation
- What else impacts CP violation discovery potential?

$$\sin \delta_{CP} = 0 \text{ exclusion defined as } \sqrt{\min_{\sin \delta=0} \chi^2(\delta_{CP} = \delta) - \min \chi^2}$$

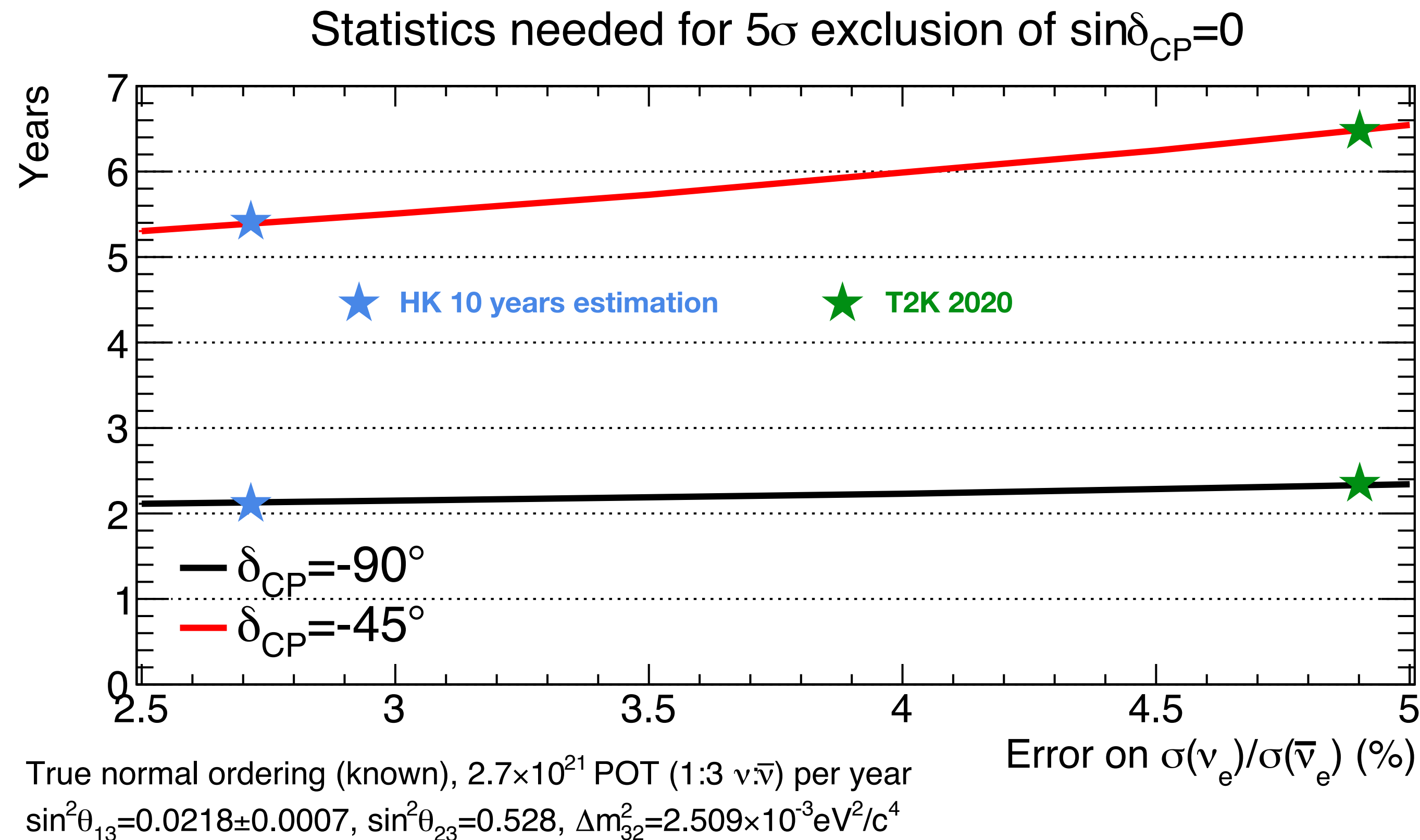

HK sensitivity

Joint fit with atmospheric

- P-theta fitter framework has the possibility to perform **joint fit between beam and atmospheric samples**
- With a much **longer propagation length**, electron flavour appearance in **atmospheric neutrinos** is much **more sensitive to θ_{10}**
- Tested on T2K + SK atm data: Phys. Rev. Lett. 134, 011801 (2025)
- **Common systematics model** built from T2K and SK atm models:
 - **T2K flux** model applied to beam samples and **SK flux** model to atm
 - **T2K and SK detector** models both used but with **correlations**
 - **T2K interaction** model applied to **all sub-GeV samples**, **SK interaction** model applied to **other atm samples**

HK sensitivity

Matter effects

- Matter effects **enhances** $\mu \rightarrow e$ flavour oscillation for ν (Normal Ordering) or $\bar{\nu}$ (Inverted Ordering) in the **multi-GeV** region for up-going atmospheric neutrinos
- Need some kind of $\nu/\bar{\nu}$ **separation!**



Hyper-Kamiokande

SK, Phys Rev D, 109 (2024) 7.

Normal

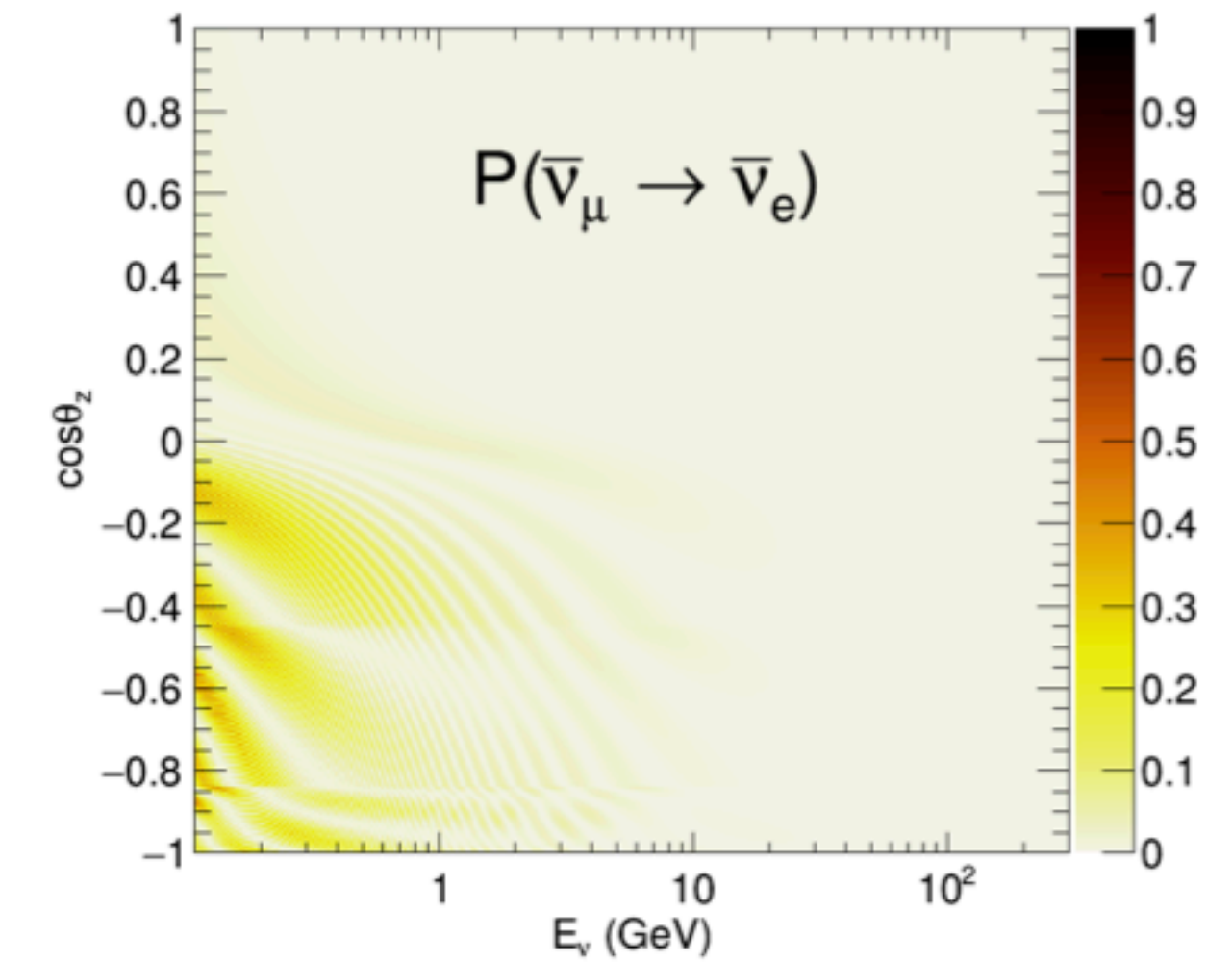
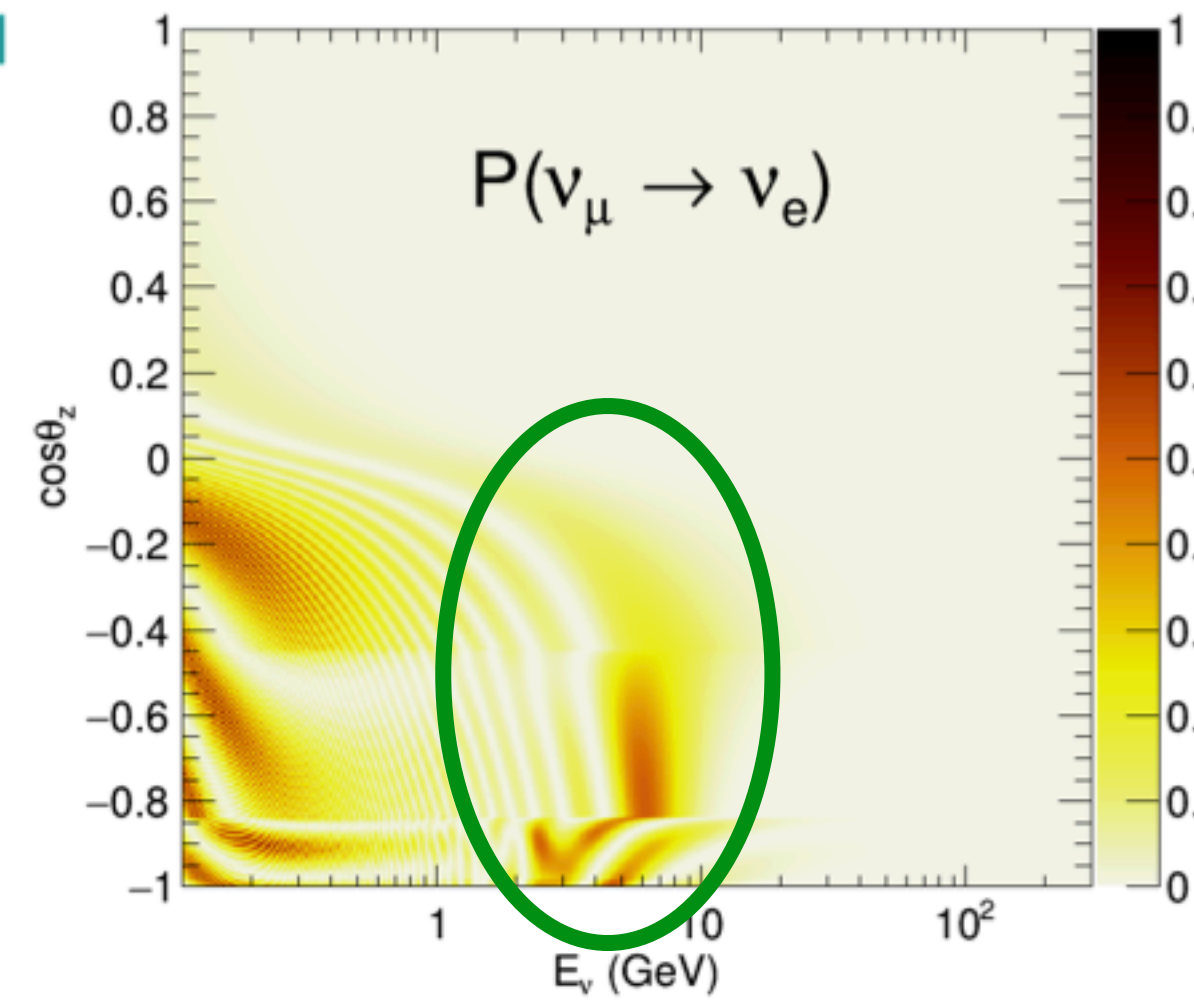

Inverted

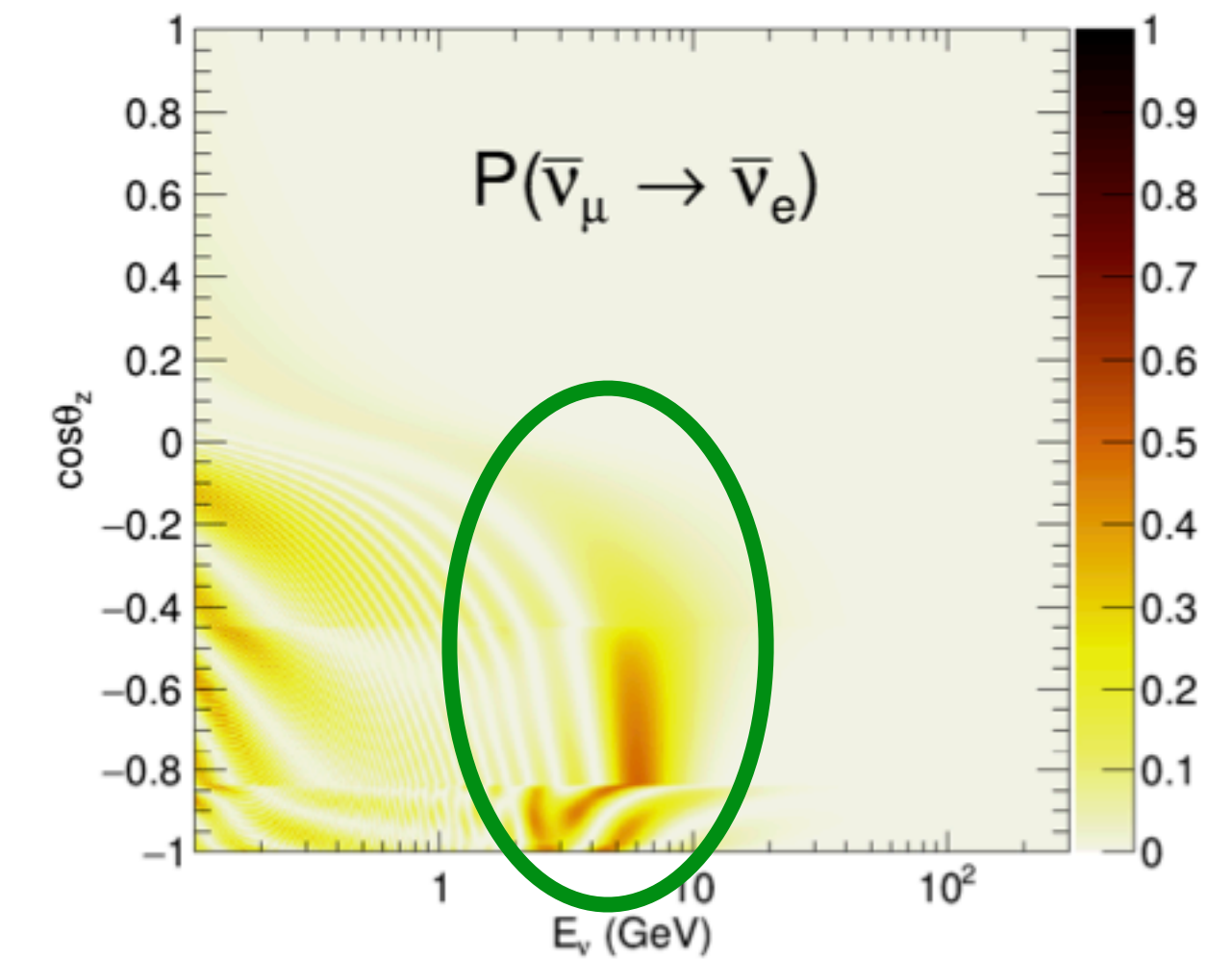
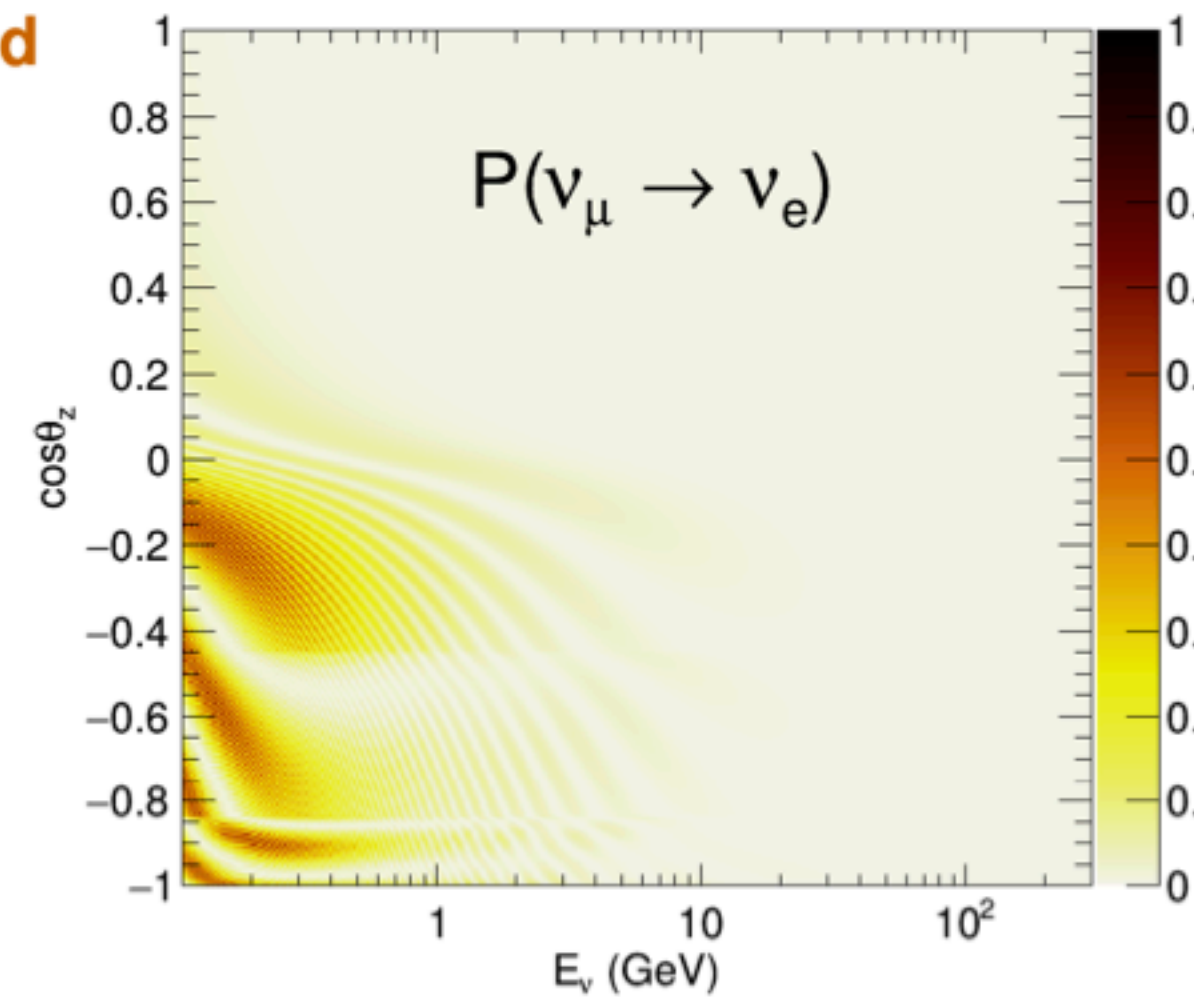

HK sensitivity

Atmospheric samples

13 **Fully contained** samples:

- **sub-GeV**: e-like + 0/1 decay e, mu-like + 0/1/2 decay e, π^0 -like
- **Multi-GeV**: e-like $\nu_e/\bar{\nu}_e$, mu-like
- **Multi-Ring**: e-like $\nu_e/\bar{\nu}_e$, mu-like, others

$\nu_e/\bar{\nu}_e$ separation based on number of decay e:

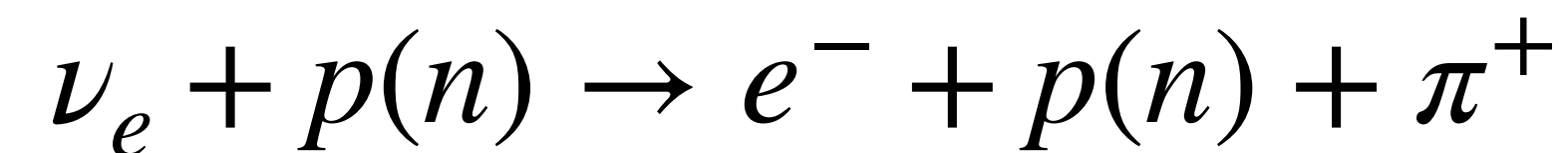

More likely to be absorbed than π^+

Fully Contained (FC)

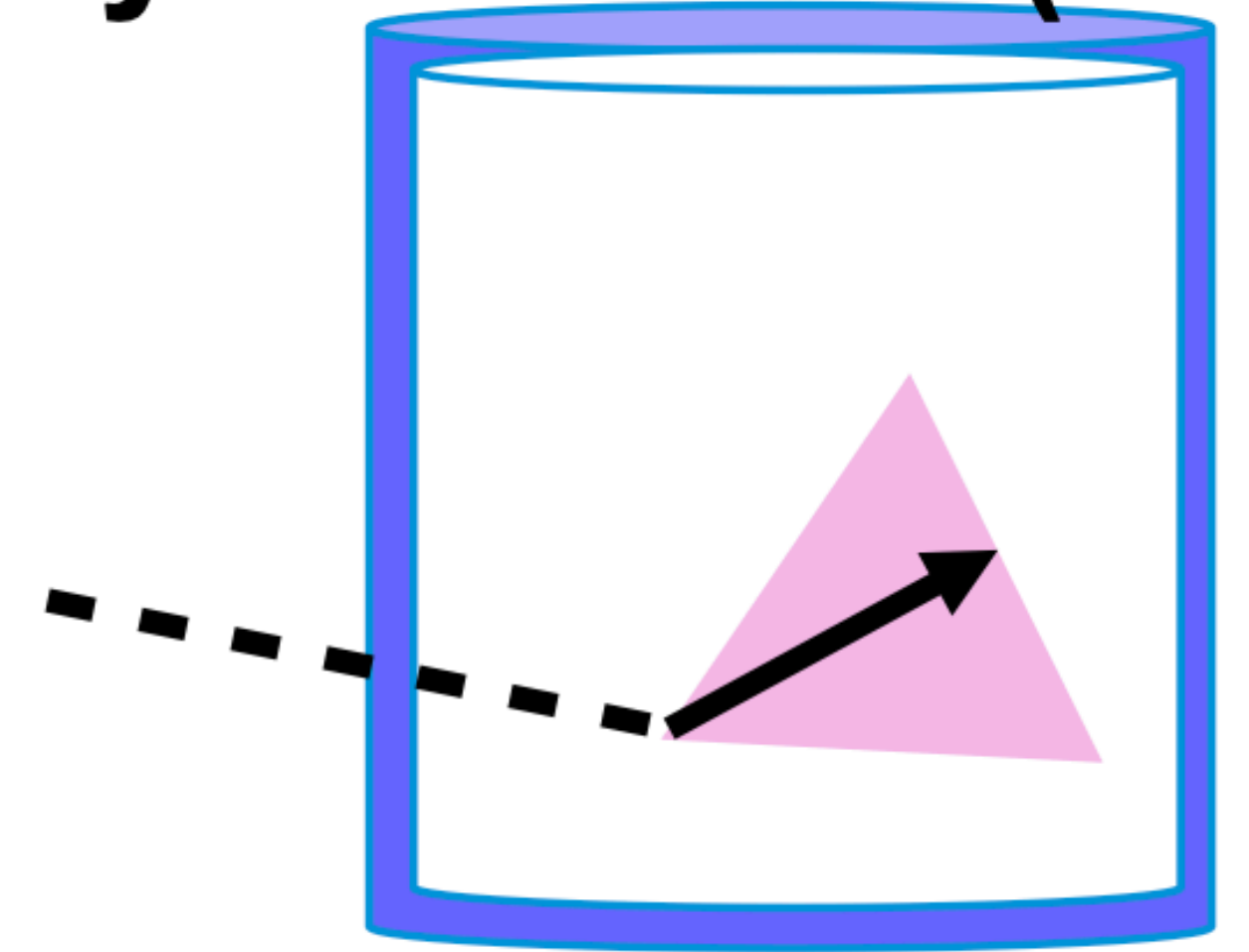

HK sensitivity

Atmospheric samples

Partially Contained (PC)

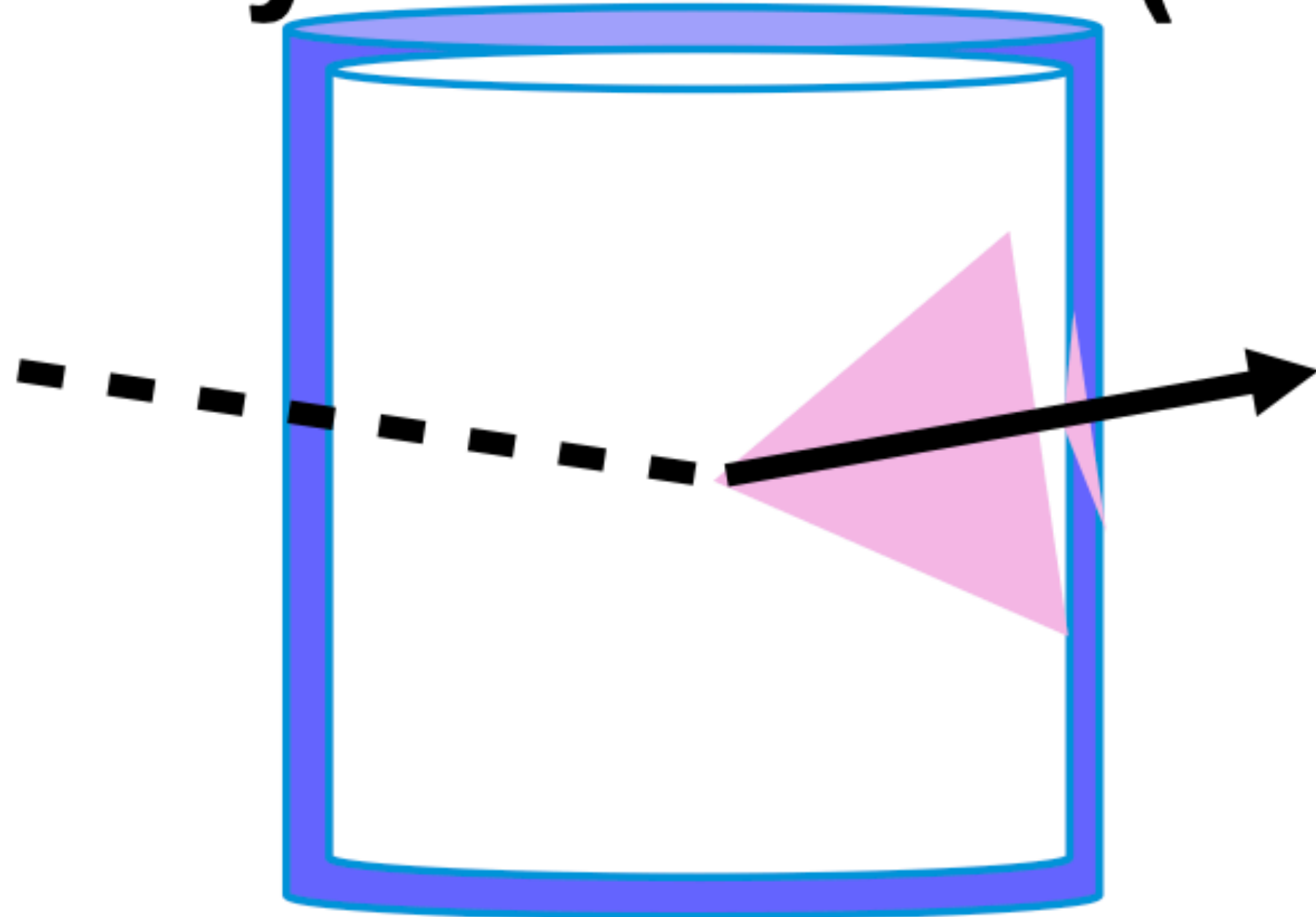

Upward-going Muons

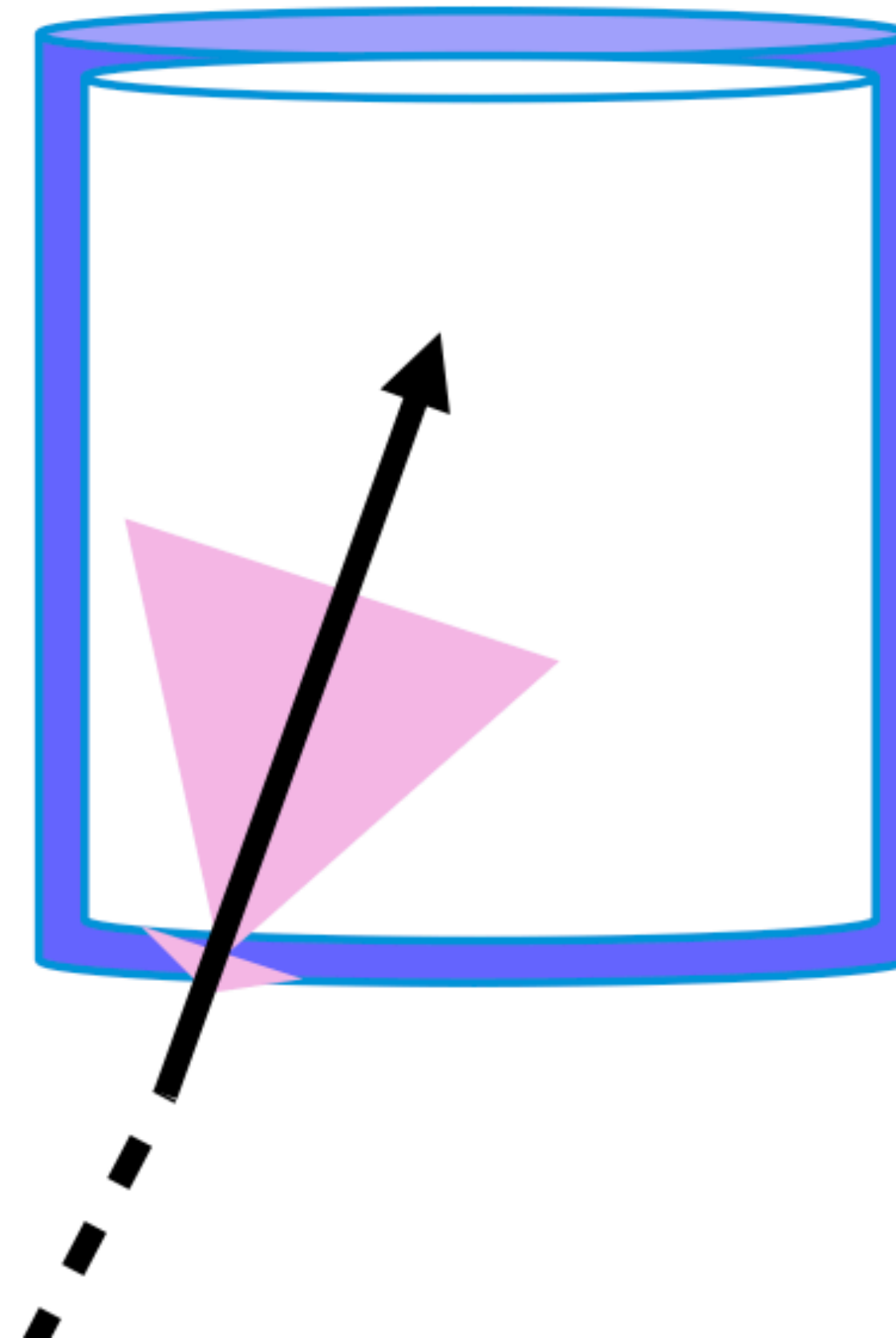

HK sensitivity

Atmospheric sensitivity to MO

up := $\cos \theta < -0.4$
 down := $\cos \theta > 0.4$

Multi-GeV e-like ν_e

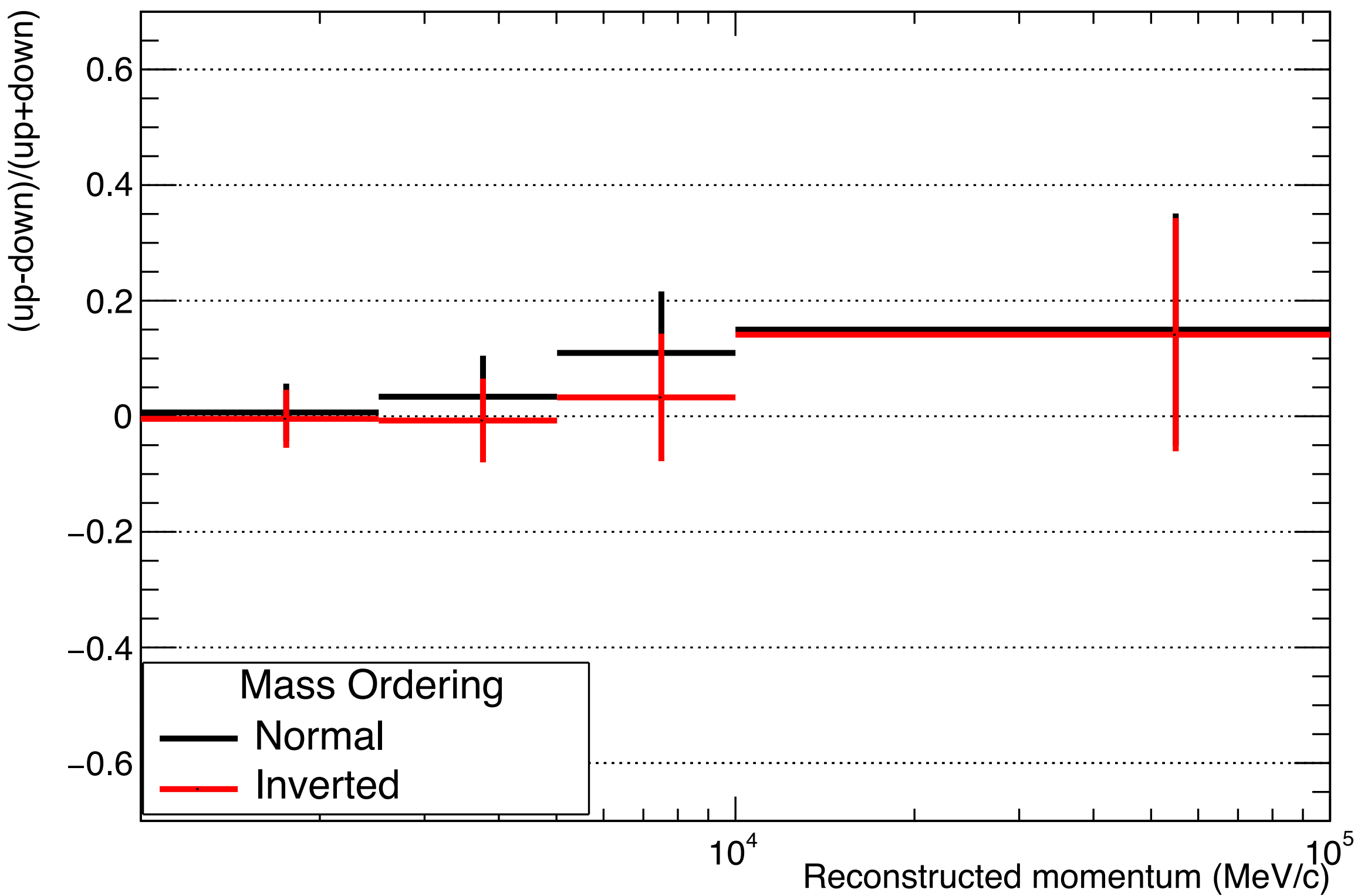

Purity in ν_e : 80%

Multi-GeV e-like $\bar{\nu}_e$

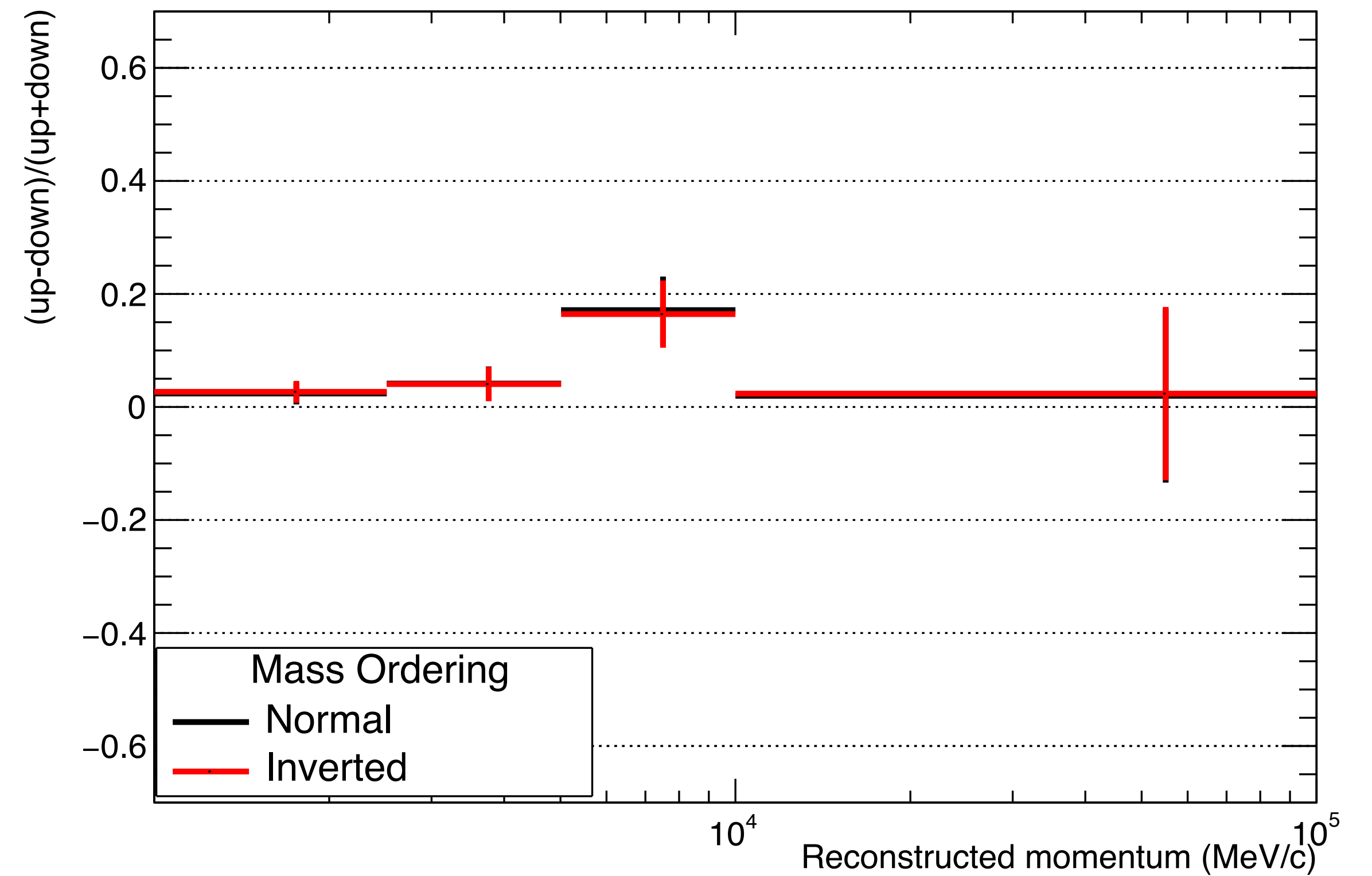

Purity in $\bar{\nu}_e$: 40%

HK sensitivity

Atmospheric sensitivity to MO

up := $\cos \theta < -0.4$
 down := $\cos \theta > 0.4$

Multi-ring e-like ν_e

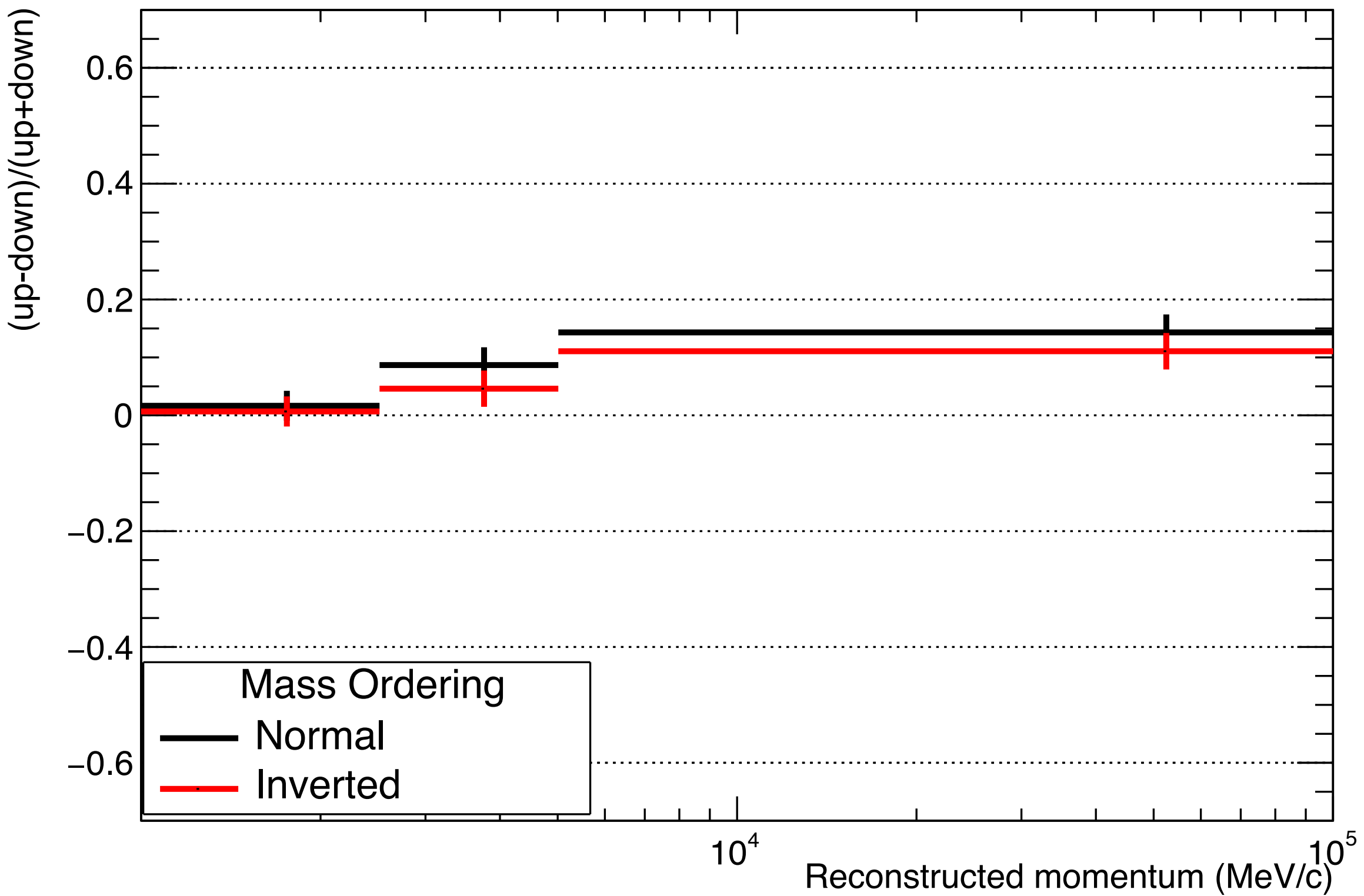

Purity in ν_e : 60%

Multi-ring e-like $\bar{\nu}_e$

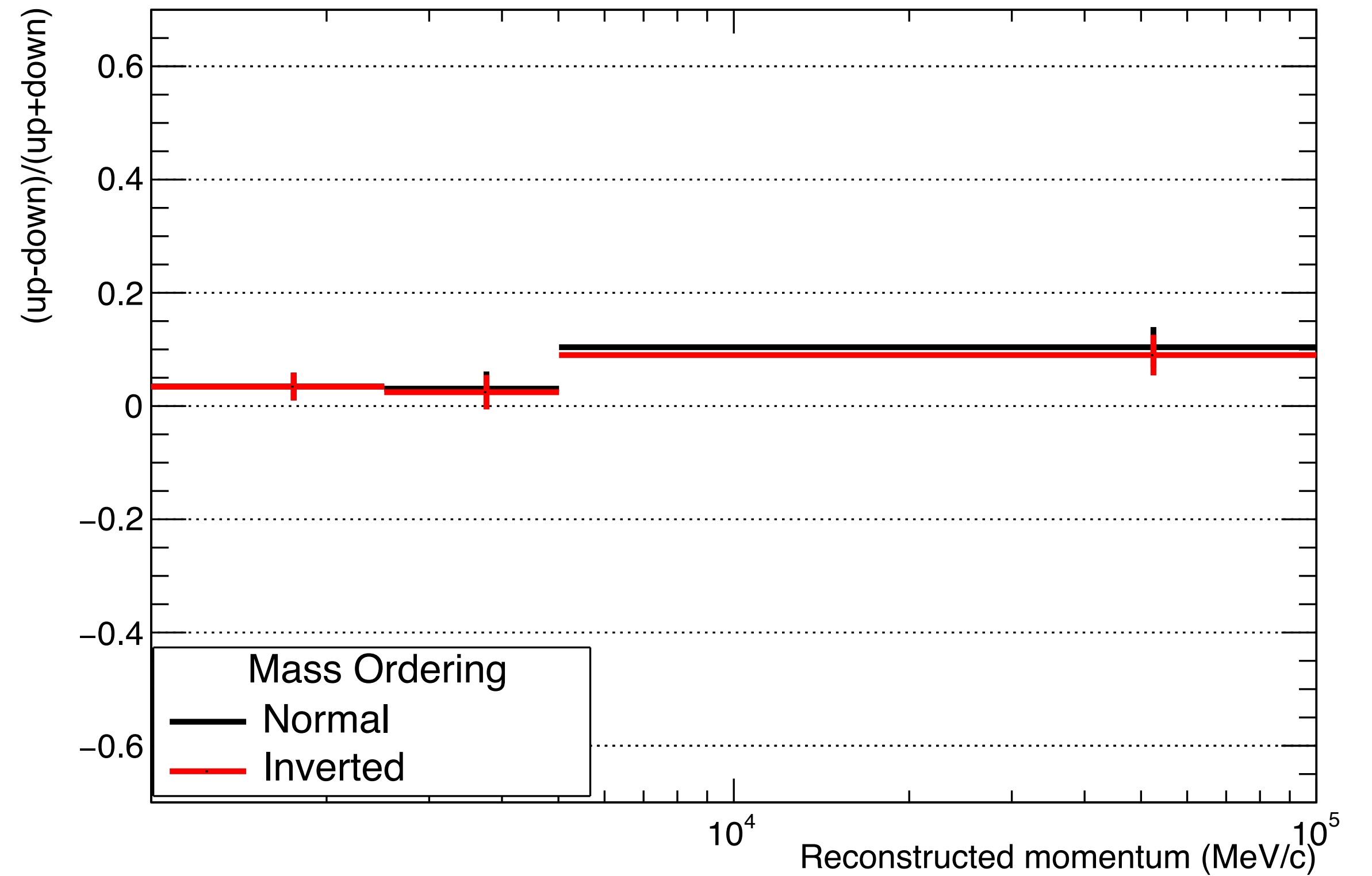

Purity in $\bar{\nu}_e$: 30%

HK sensitivity

Atmospheric sensitivity to MO

up := $\cos \theta < -0.4$

down := $\cos \theta > 0.4$

Wrong MO exclusion: $\sigma_{\text{MO}} = \sqrt{\chi^2(\text{wrong MO}) - \chi^2(\text{right MO})}$

Multi-GeV e-like ν_e

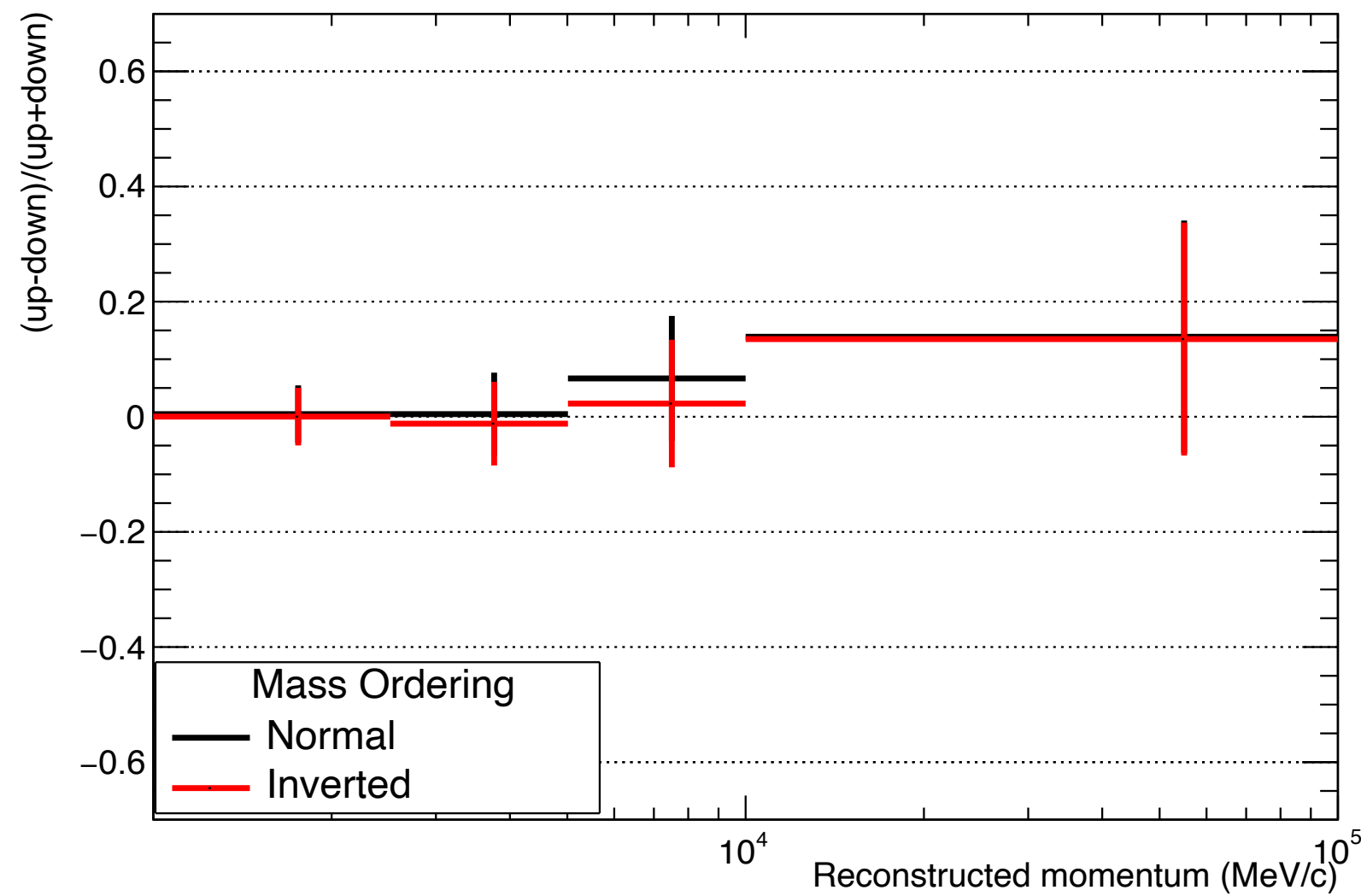

$$\sin^2 \theta_{23} = 0.4, \sigma_{\text{MO}} = 2.1$$

Multi-GeV e-like ν_e

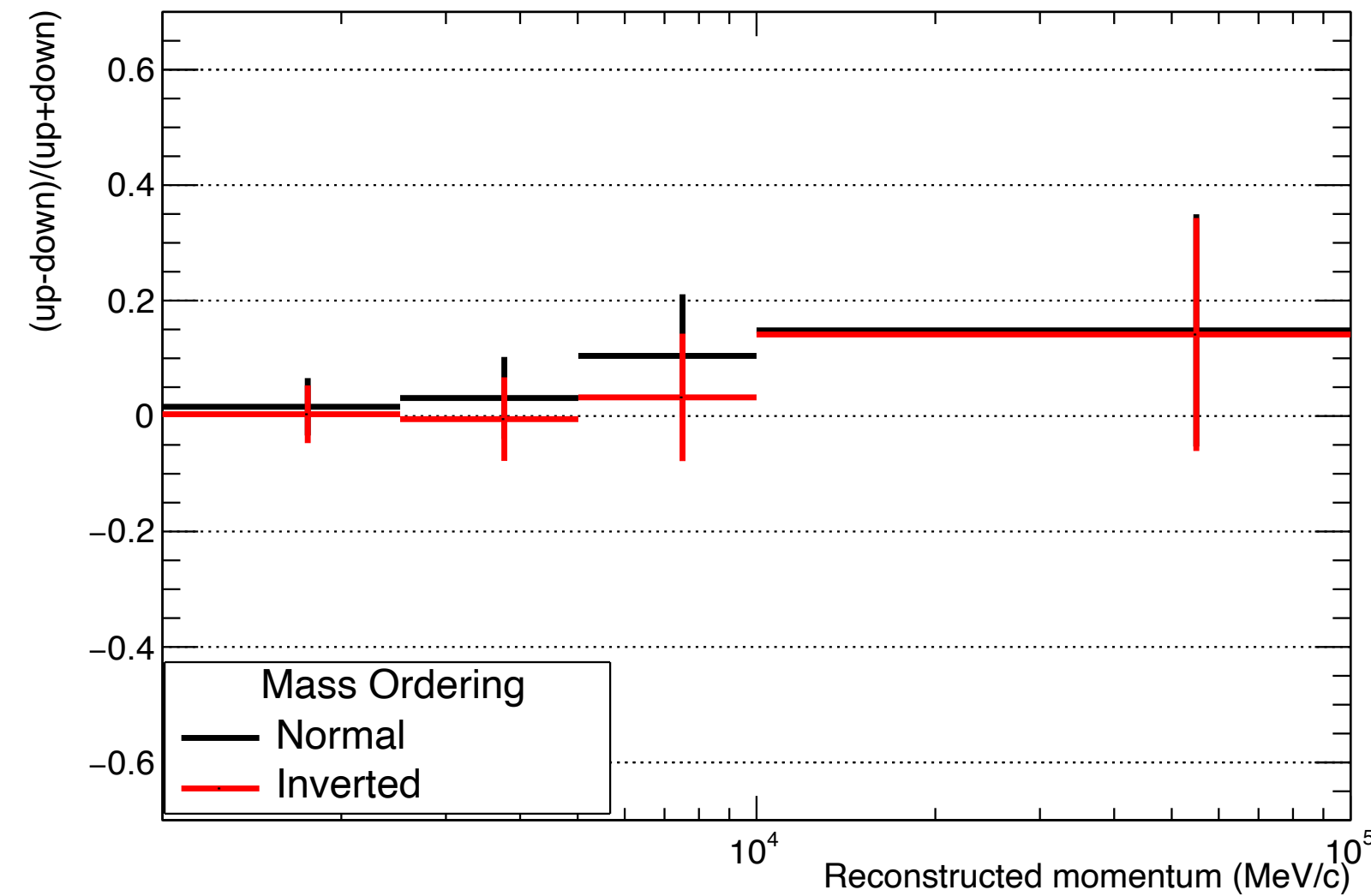

$$\sin^2 \theta_{23} = 0.5, \sigma_{\text{MO}} = 3.7$$

Multi-GeV e-like ν_e

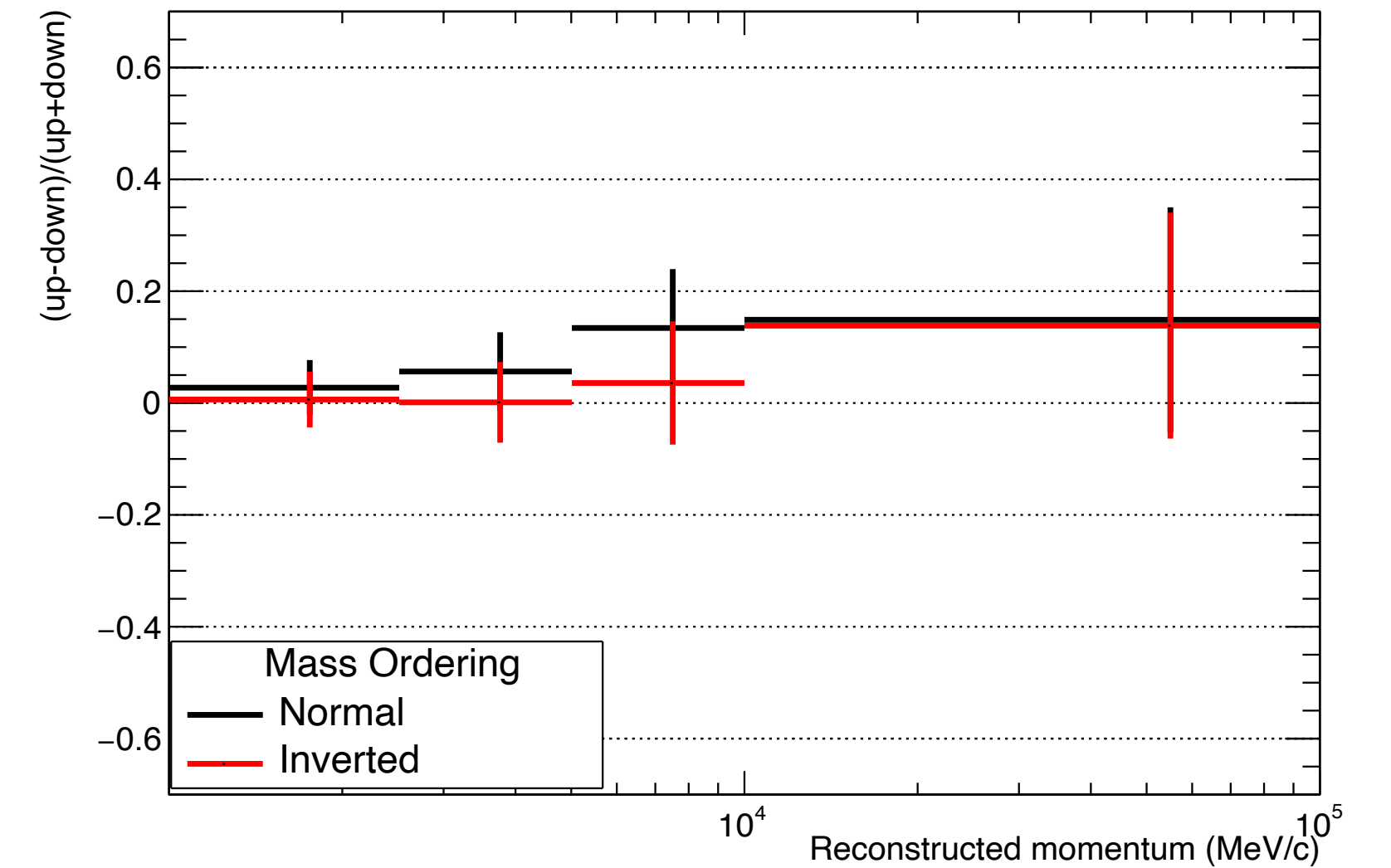

$$\sin^2 \theta_{23} = 0.6, \sigma_{\text{MO}} = 5.2$$

Matter effects are proportional to $\sin^2 \theta_{23}$

HK sensitivity

Atmospheric sensitivity to MO

Systematic uncertainties improved model:

- **T2K 2020 parameters:** same reduction as before
- **Atm parameters** (flux, xsec, detectors) + **T2K xsec high E:** 50% reduction of prior, except for
 - ▶ **xsec nu_tau:** prior at 5%
 - ▶ **NCPI0:** prior at 5%

25% prior error in SK model

Systematics included	NO
None	4.16
xsec sub-GeV	4.14
xsec multi-GeV	3.61
xsec nu_tau	3.72
Xsec all	3.47
Atmospherics flux	3.92
Atmospherics detector	3.97
All	3.23

Wrong MO exclusion in number of σ for 10 years exposure ($\sin^2 \theta_{23} = 0.528$) to atmospheric neutrinos (the T2K-SK model of systematic uncertainties was applied without prior improvements).

HK sensitivity

Atmospheric sensitivity to MO

Wrong MO exclusion: $\sqrt{\chi^2(\text{wrong MO}) - \chi^2(\text{right MO})}$

$\sin^2 \theta_{23}$	NO	IO
0.4	2.1	2.1
0.5	3.7	3.7
0.6	5.2	5.3

Wrong MO exclusion in number of σ for 10 years exposure and including only statistical uncertainties

Systematics included	NO
None	4.16
xsec sub-GeV	4.14
xsec multi-GeV	3.61
xsec nu_tau	3.72
Xsec all	3.47
Atmospherics flux	3.92
Atmospherics detector	3.97
All	3.23

Wrong MO exclusion in number of σ for 10 years exposure ($\sin^2 \theta_{23} = 0.528$)

25% prior error in SK model

HK sensitivity

Degeneracy with MO

- In previous slides, considered MO known (True NO)
- But there is a degeneracy between δ_{CP} and MO in beam samples
- **If MO is unknown**, sensitivity to CP violation is degraded in **degenerate** regions
- **Adding atmospheric samples** (recently started) help lift the degeneracy by better constraining the MO

Normal Ordering
(unknown)

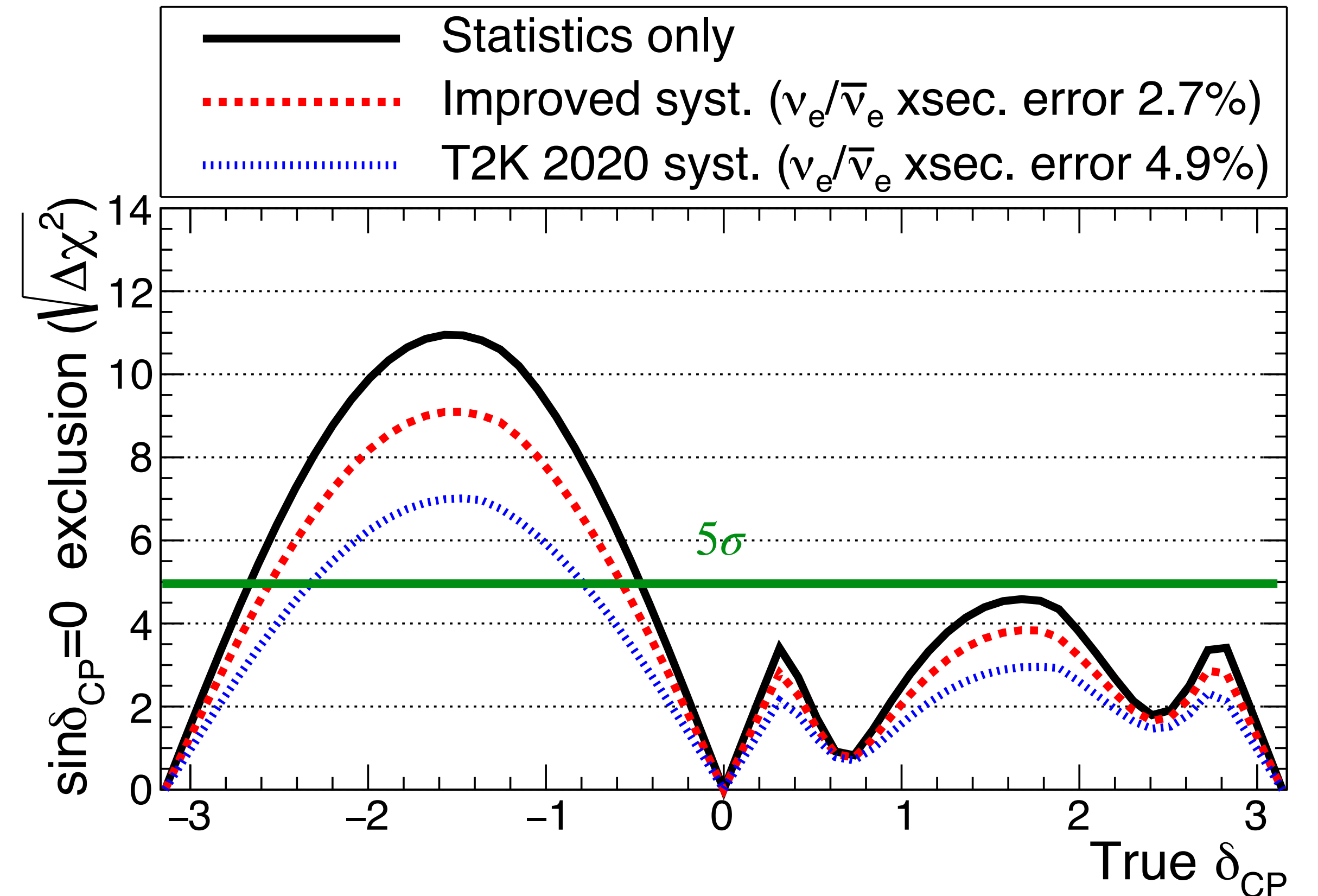

Hyper-K preliminary

True normal ordering (Unknown), 10 years (2.7×10^{22} POT 1:3 $\nu:\bar{\nu}$)

$\sin^2\theta_{13}=0.0218\pm 0.0007$, $\sin^2\theta_{23}=0.528$, $\Delta m_{32}^2=2.509\times 10^{-3}\text{eV}^2/c^4$

In improved systematics, prior errors of parameters measured at ND280 are scaled with statistics compared to the improved model at 10 years.

HK sensitivity

Joint fit sensitivity to CP violation

degenerate region

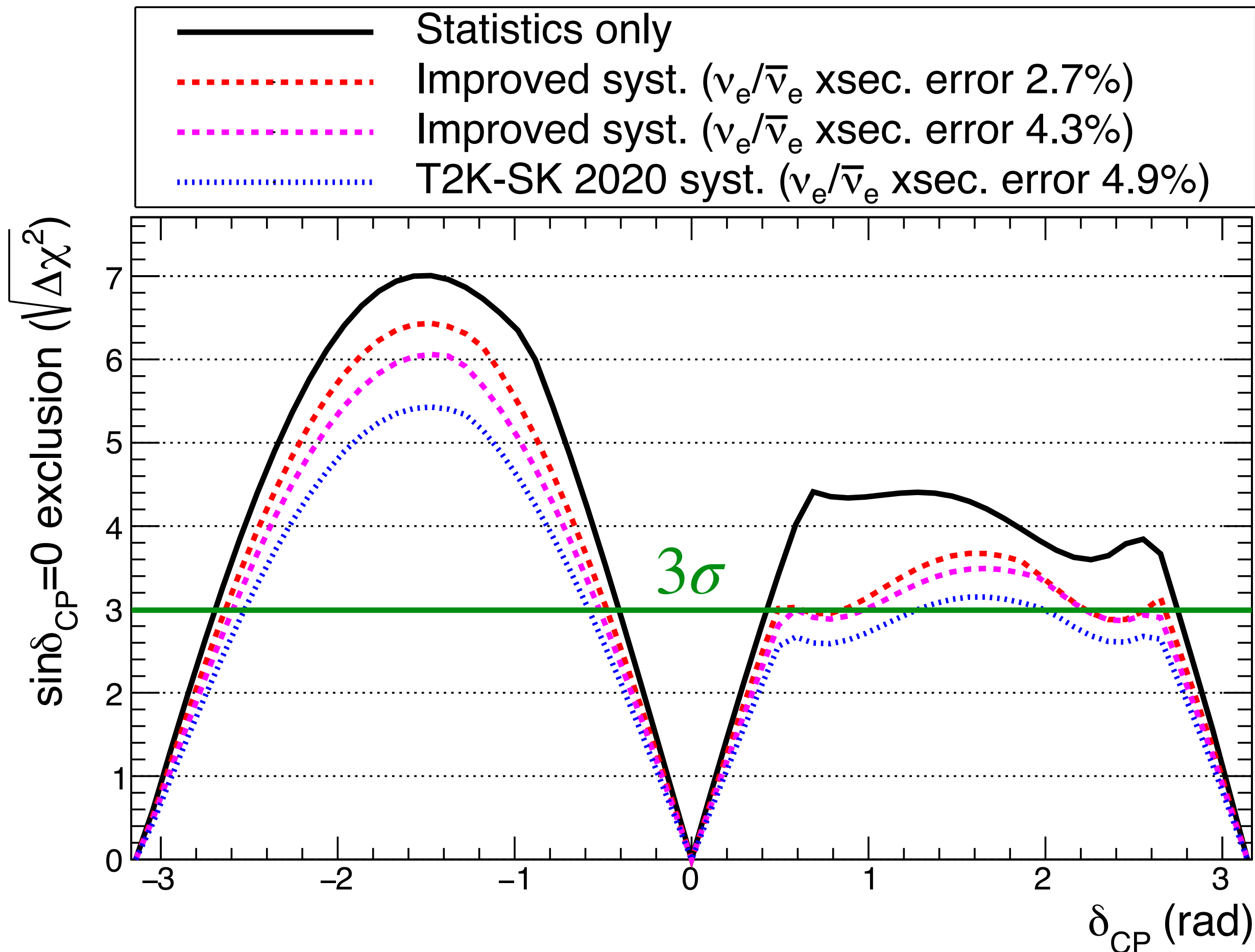

4 years exposure to beam + atmospheric

Error model	Sindcp<0	sindcp>0
Stat only	73 %	72 %
Imp (2.7%)	70 %	49 %
Imp (4.3%)	65 %	38 %
T2K-SK 2020	59 %	25 %

Number of values of δ_{CP} for which $\sin \delta_{CP} = 0$ can be excluded at 3σ

Exclusion of CP symmetry soon becomes limited by systematic effects, including in the degenerate region!

HK sensitivity

T2K detector systematics model

- **Detector effects** (PMTs imperfections, water transparency) can **bias the event reconstruction** (mis-identification, bias in energy/momentum reconstruction etc.)
- These effects are **measured in control samples** (data/MC ratio): atmospheric stopping muons, cosmic ray muons etc.
- In the T2K model, the uncertainties are encoded via **parameters that re-normalise the number of events** per sample, interaction type (CC or NC) and energy
- An additional parameter allows **migration from one energy bin to another**: the **energy scale** parameter