



**TYL FJPPN  
/ FKPPN  
2026  
Hamamatsu**

## **Characterization of the upgraded J-PARC neutrino beam for T2K-II and HK experiments**

Romain Gaïor on behalf of the NU\_09 project

**LPNHE**  
PARIS  
I L  N C E

# Context of NU\_09:

## Motivation:

- $\nu$  oscillation with long baseline
- Broad  $\nu$  physics program
- Search for CP violation

## Tools

- T2(H)K
  - Beam from JPARC
  - Near Detector
  - Far Detector (Super / Hyper Kamiokande)
- NA61/SHINE
  - CERN based experiment to study the beam condition of T2K

## Goal specific to NU-09:

- Improve the beam condition
- Characterize the beam
- Prepare future

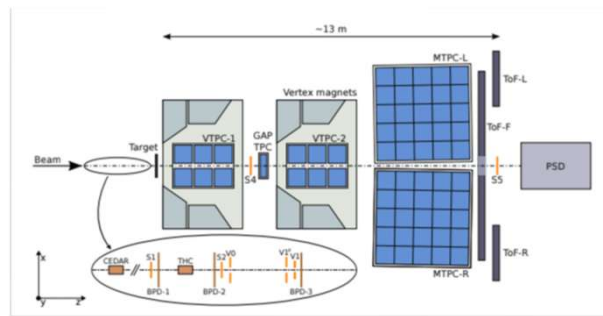
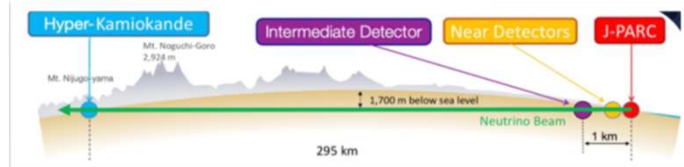

2

The scientific context of NU09 is the neutrino physics in particular with long baseline accelerator experiment  
 Large potential in the understanding of neutrino properties.  
 Strong focus on the search for CP violation in the neutrino sector  
 To do this, we use the T2K facility that comprises a neutrino beam produced at JPARC, a precise near detector and a far detector aka SK or HK in the near future.  
 Additionally, the cern based experiment NA61/SHINE allows for the precise characterization of the neutrino beam by replicating neutrino production part.

The NU09 project focuses on the improvement of the current beam condition and its characterization, and also to prepare the future with the development of hardware contribution and sensitivity studies for HK.

# France-Japan collaboration

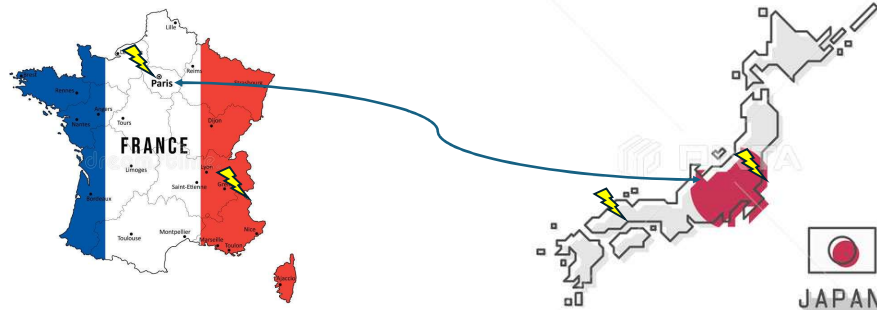

## LPNHE / CERN

- Boris POPOV
- Claudio GIGANTI
- Romain GAIOR
- Mathieu GUIGUE
- Lorenzo RESTREPO
- Maria Adriana SABIA
- Stefano RUSSO
- Vincent VOISIN
- Claire DALMAZZONE

## KEK / Okayama

- Ken SAKASHITA
- Yoshikazu NAGAI
- Yota HINO
- Megan FRIEND
- Yusuke KOSHIO
- Ayana ASAI
- Yuki SHIRAIISHI
- Takeshi NAKADAIRA
- Sakiko NISHIMORI

3

The effort has profited for a long time of the French Japan collaboration. In this project, the people involved, at LPNHE and CERN and in Japan KEK and Okayama University, have strong implication in the hardware and software development for the goals mentioned earlier.

**Q: just to know if I am asked : how was used the FJPPN budhet last year ?**

# Beam operation and characterization at JPARC

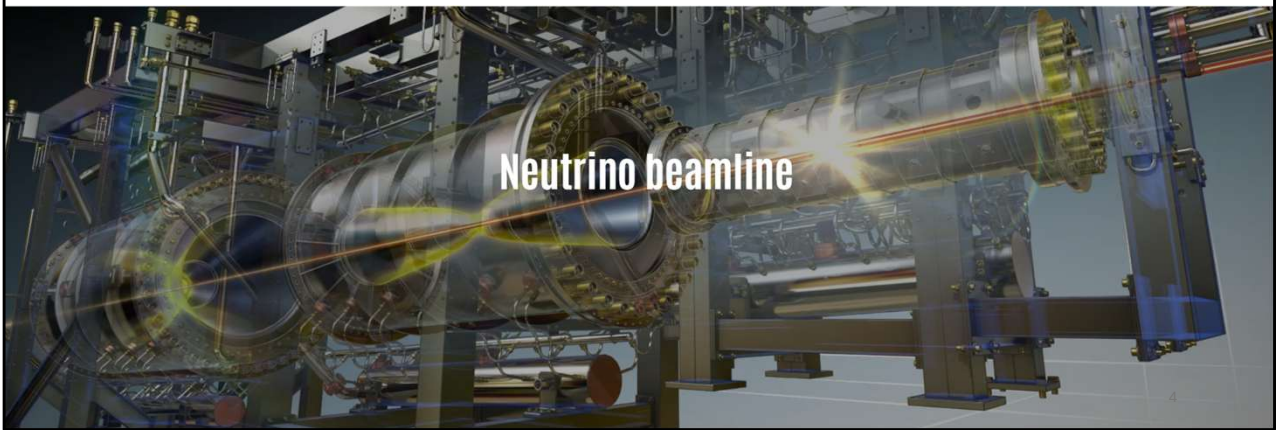

# Beam Operation at JPARC

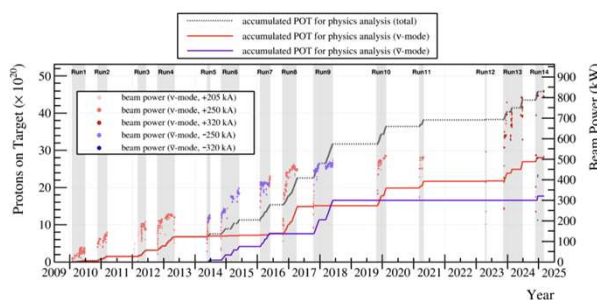

- Upgrade of JPARC MR  
Cycle time from 2.8s/spill to 1.3s/spill
- Operation of the magnetic horn at 320kA  
(instead of 250kA)
- Dedication of JPARC team

- ✓ 1MW beam ! On track to reach 1.3MW in 2028
- ✓ The statistics increases ?? POT

5

The recent upgrade on the beam line has allowed the accumulation of high POT statistic

The JPARC Main ring got upgraded to increase the rate from 2.8s/spill to 1.3s/spill

The magnetic horn is now operated at larger current and allow a more efficient focusing of the produced Pions, and in turn increased number of neutrinos

This is illustrated by the screen shot of the Beam status earlier this year that reach > 1000 kW !

**Q: what is the current statistics accumulated ?**

**Q: what is the status of the beam ? Official message ?**

# Beam Characterization

# $\nu$ flux estimation with NA61/SHINE



# History of the data-taking for T2K

## C target + proton@31 GeV/c run

	2007年	2009年	2010年	2022年
Thin:	$0.7 \times 10^6$ POT	$5.4 \times 10^6$ POT	-	-
Replica:	$0.2 \times 10^6$ POT	$2.8 \times 10^6$ POT	$10. \times 10^6$ POT	$180. \times 10^6$ POT

18 times →

<Thin target> (in use: 2009 data set)

- Target length: 2 cm
- Measured value:  $d^2\sigma/dpd\theta$
- The double differential production cross section is measured from the primary interactions.

<T2K replica target> (in use: 2010 data set)

- Target length: 90 cm (the same as T2K)
- Measured value:  $d^3N/dzdpd\theta$
- The hadron yields at the target surface are measured, and they can be used for the yield tuning directly.

Slide from S. Nishimori

1

8

The NA61/SHINE allows to reproduce the interaction happening at the T2K neutrino production site.  
 It replicates the beam and target condition.  
 Going from a thin target to a long one requires some change in the simulation and analysis because now you probe also multiple interaction inside the target.

# T2K replica target + proton@31 GeV/c run (2022)

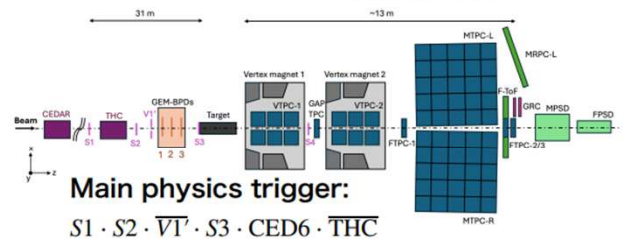
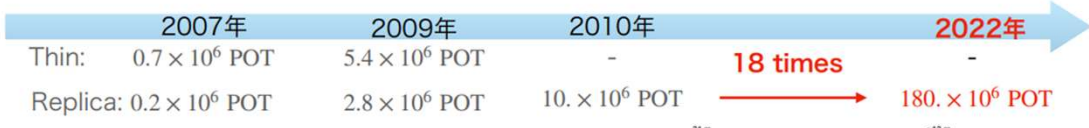

Particle	Thin (2 cm)	Replica (90 cm)	Plan with 2022 dataset
$\pi^+/\pi^-$	✓ (2009)	✓ (2010)	
$K^+/K^-$	✓ (2009)	△ (not enough)	Measurement of the high energy charged kaons
$p$	✓ (2009)	✓ (2010)	
$K_S^0$	✓ (2009)	✗	First measurements using a T2K replica target
$\Lambda$	✓ (2009)	✗	

- NA61/SHINE measures the differential production yield for each momentum and angle of  $K_S^0$ .
- The results are input to a T2K beam simulation to estimate  $K_L^0$  production at T2K.
- The analysis in NA61/SHINE is performed by reconstructing the trajectory for the process of  $K_S^0 \rightarrow \pi^+ + \pi^-$ .

Slide from S. Nishimori

The replica target is shown in the picture and the studies made previously with the thin one are being updated with a larger statistic acquired in 2022. In particular, the neutral baryon analysis and the measurement of  $K_0$  and Delta flux

The steps to estimate this contribution is:

- First measure the production yield of the  $K_0$ s with NA61/SHINE
- Then use it as input for the T2K beam simulation to estimate the  $K_0$ L for T2K

# The motivation of $K_S^0$ measurement (1)

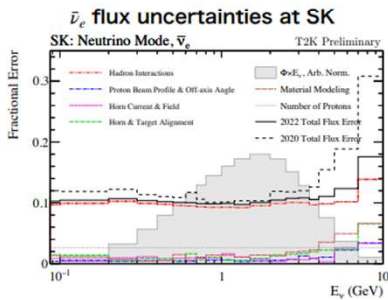
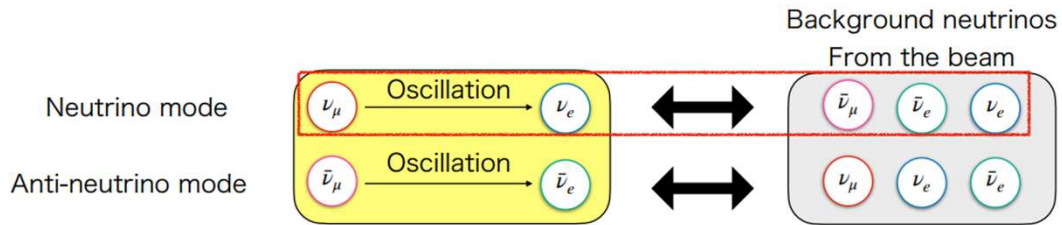

Main component

$K_L^0 \rightarrow \pi^+ + e^- + \bar{\nu}_e$

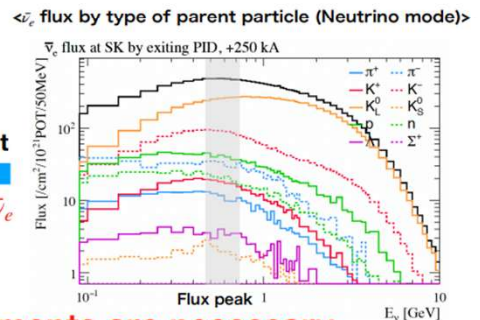

Additional NA61/SHINE measurements are necessary.

Slide from S. Nishimori

3

10

This is important for oscillation studies is because  $K_S^0$  is largest contribution in the  $\nu_e$  and  $\bar{\nu}_e$  beam contribution which is one of the main uncertainty on the flux expected at SK.

# $K_S^0$ analysis status

- The data analysis is currently under review within the NA61 collaboration, and results will be published soon.
- Invariant mass fits are performed well for each kinematic bin.

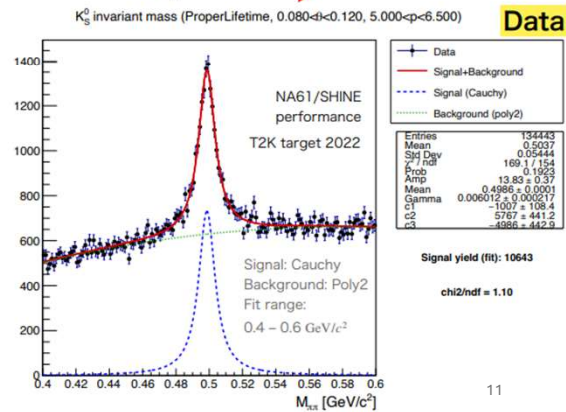
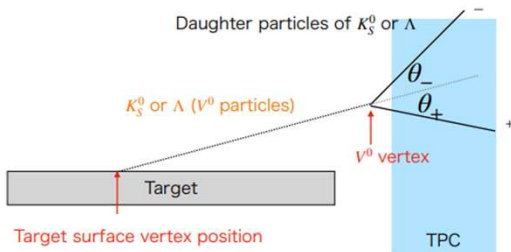
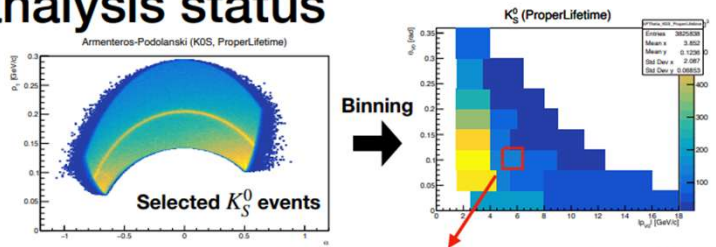

Slide from S. Nishimori

5

11

The data analysis was carried out by S. Nishimori and the results are under collaboration review before submission for publication. The top plot show the purity of the KOS sample, then the invariant mass is fitted for each bin in angle and momentum.

**Q: Is it correct that the Armenteros plot is here to show the purity of the data sample ?**

**Q: how the invariant mass information is used ? Is it just to subtract the the background and get the correct number of KOS for this particular angle and momentum ?**

# Hyper Kamiokande:

Sensitivity studies  
Timing system development

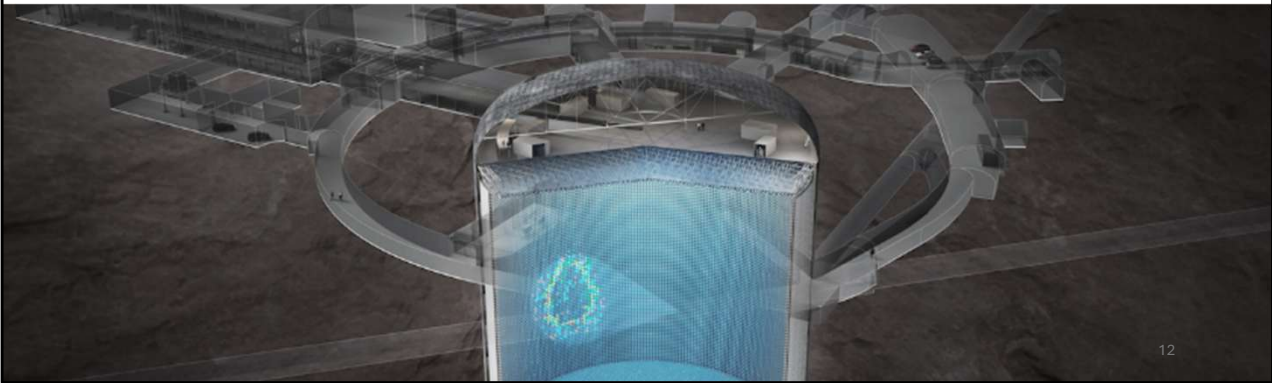

# Sensitivity studies

See the award winner talk !  
(Monday 18/05)



**Hyper-Kamiokande**

**Sensitivity studies for neutrino oscillation parameters measurement and time synchronisation system for the Hyper-Kamiokande experiment**

Claire Dalmazzone

LPNHE PARIS

SORBONNE UNIVERSITE

TYL/FJPPN Young Investigation Award Ceremony, Monday May 18th

# Timing system development for HK

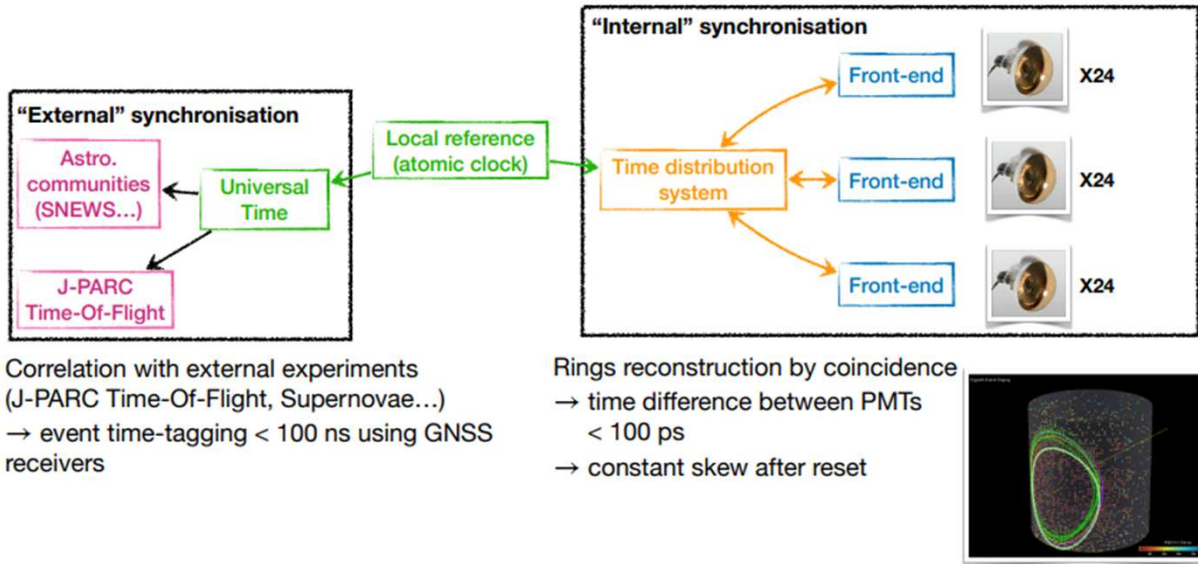

Slide stolen from M. Guigue (EPS2025)

The timing system of HK needs to respect two main requirements:

- An absolute time resolution lower than 100ns for external correlation, this is achieved thanks to a GNSS receiver system
- A synchronization of all the end point (Front end electronics attached to the 20 000 PMTs) better than 100ps. This is achieved using an atomic clock that fuels a time distribution system.

So the short term precision is kept with the atomic clock and the longer term is insured with the GNSS. In the mean time, online and offline correction can be implemented (see Claire's talk)

To precisely share the timing information across all the electronics vessels we need the Time distribute system developed partly at LPNHE.

- The TDM board is designed to:
  - Receive master clock and distribute it with jitter at the endpoint < requirement
  - Guarantee a constant channel to channel phase difference over each reset and power up compensating the differences introduced by different cable lengths
  - Guarantee a bidirectional data bandwidth > 100 Mbps
  - Communicate to the DAQ system to exchange slow control data.
  - Redundant optical fiber link to each FE to be activated by a software command

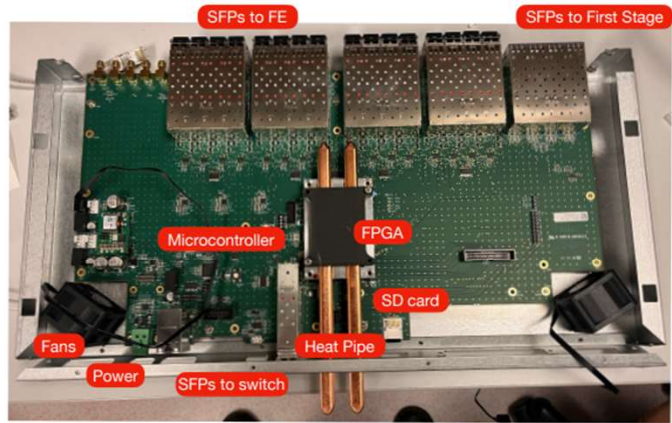

- Main element : a Xilinx XCZU9EG Zynq ultrascale+ SoC FPGA
  - FPGA comes pre-assembled on a electronics board hosting main power supply section, a double data rate (DDR) memory for the processor etc... no complex routing on the board
  - Link between the TDM and the system-on-module with 4 high-speed connectors with 160 pins each

Describe the main function of the TDM and the implementation



## Integration: assembly procedure



- Assembly and testing procedure ready to be handled to external company (OUESTRONIC)
  - Goal: screening of faulty components and bad solderings
  - Procedure:
    - Physical installation: populated board fixed on a dedicated support, external components are mounted (mezzanine module, SFPs, SD card and cables)
    - Automatic tests: board switched on, ID info collected and network configured. Board parameters checked (voltages, current, temperature). Bit error rate measurement is done on all links.
    - Physical disassembly: the operator checks that data is collected and removes the SD card.

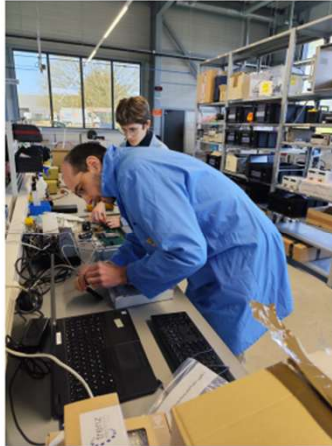

Demonstration @ OUESTRONIC



- At the end of the tests, the TDM is either ready to be used or declared faulty
- A report is posted on the github page of the tests.

Slide from M.A. Sabia

16

Describe the production situation:

Pre prod done, production to be done in 2026

Development of automatic test before integration at LPNHE



# Integration

- Fully equipped rack to mimic the configuration at Hyper-K
- 4 latest version TDMs up and running
- One TDK Lambda power supply
- One switch
- External fans for additional ventilation (exploits the heat pipe)
- Slow control via MIDAS to monitor temperature, voltages etc.

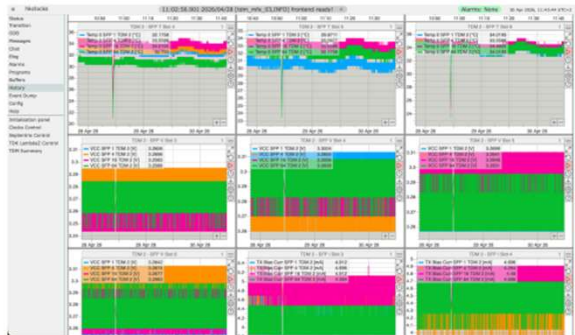

Slide from M.A. Sabia

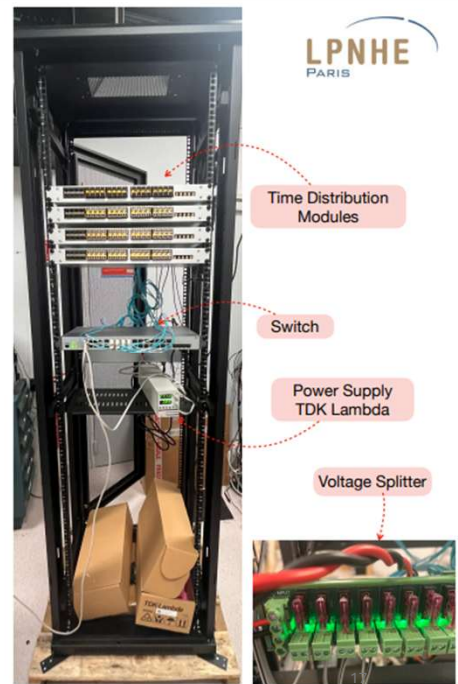

Integration work took place at LPNHE with final HW and Monitoring tools used at HK

Describe quickly the system

Prepare the shipment to Japan in 2027.

## Installation at JPARC

- Needs synchronization between the beam and far detector
  - Similar timing generation and distribution system needed at JPARC
  - Dedicated link between JPARC timing and TDM
- Antenna support designed at LPNHE
- Just shipped and Installed at JPARC
- Planned test (06/2026): integration of TDM board with the JPARC beam timing system

GNSS Antenna installed at JPARC Neutrino building



## Conclusion

- NU\_09 project focused on the oscillation studies with T2(H)K:
  - Beam characterization (JPARC) and calibration (NA61/SHINE)
  - Development of timing system for HK
  - Sensitivity studies for HK
- Exciting time for the project:
  - NA61/SHINE:
  - T2K Beam:
  - Timing system:
    - Production in 2026
    - Integration and installation site in 2027

19

**Q: what are the next steps for the NA61/SHINE analysis and T2K Beam ?**