

Early identification of optical tidal disruption events

progress towards Rubin data

S.Karpov

M. Llamas Lanza, E. Russeil, E. Quintin,
E. Ishida, M. Pruzhinskaya, A. Möller, J. Peloton



Co-funded by
the European Union



Ministry of Education,
Youth and Sports
of the Czech Republic



Fyzikální ústav
Akademie věd ČR, v. v. i.

Tidal Disruption Events

disruption -> collisions -> circularization

Disruption of a star on its passage near SMBH

- bound material returns in a \sim month
- fallback rate $\sim t^{5/3}$
- circularization after \sim year

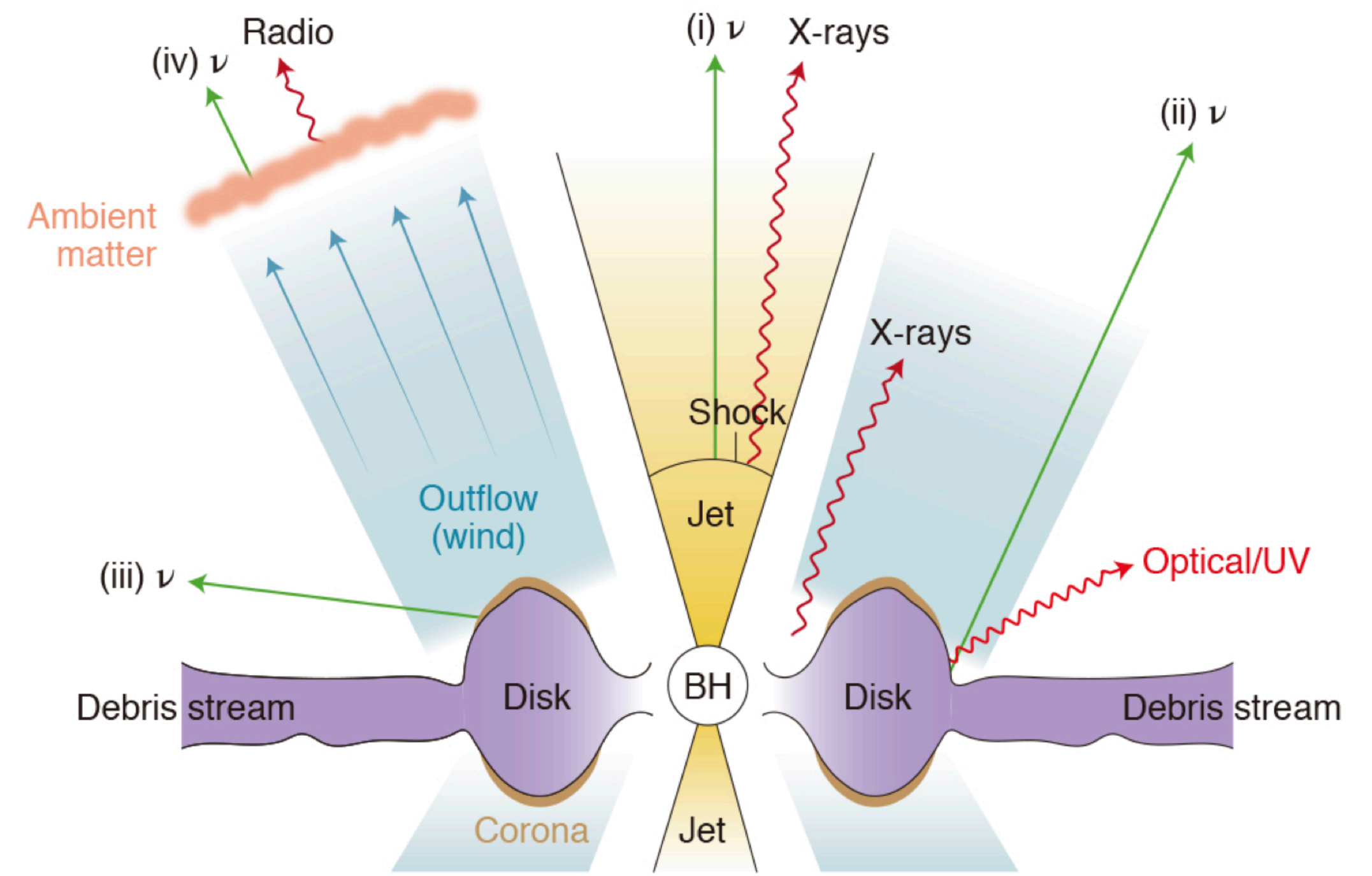
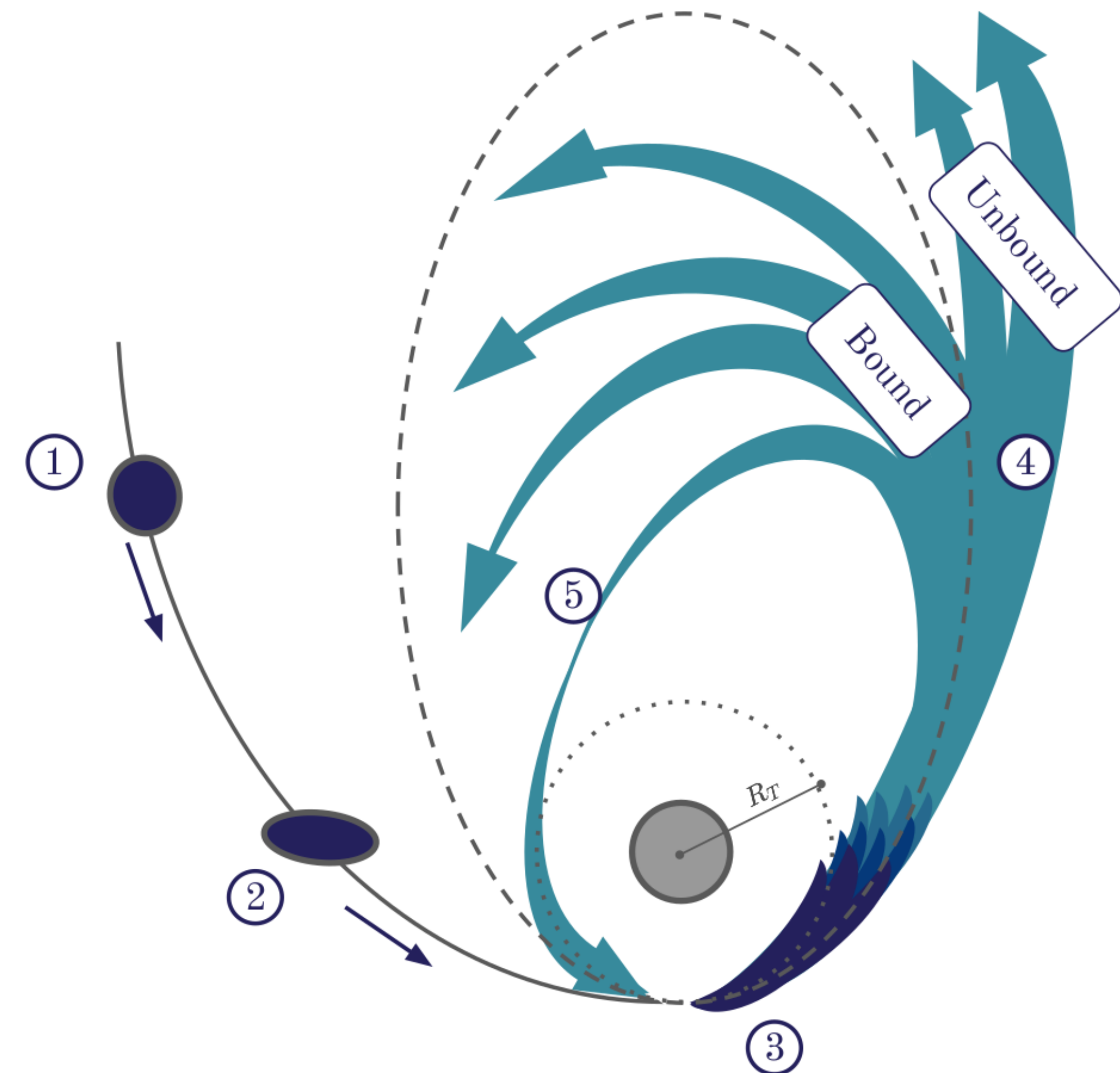

accretion -> X-rays -> reprocessing -> UV/optical

Tidal Disruption Events

Disruption of a star on its passage near SMBH

- peak in ~weeks
- post-peak brightness $\sim t^{5/3}$
- $M \sim -17..-20$

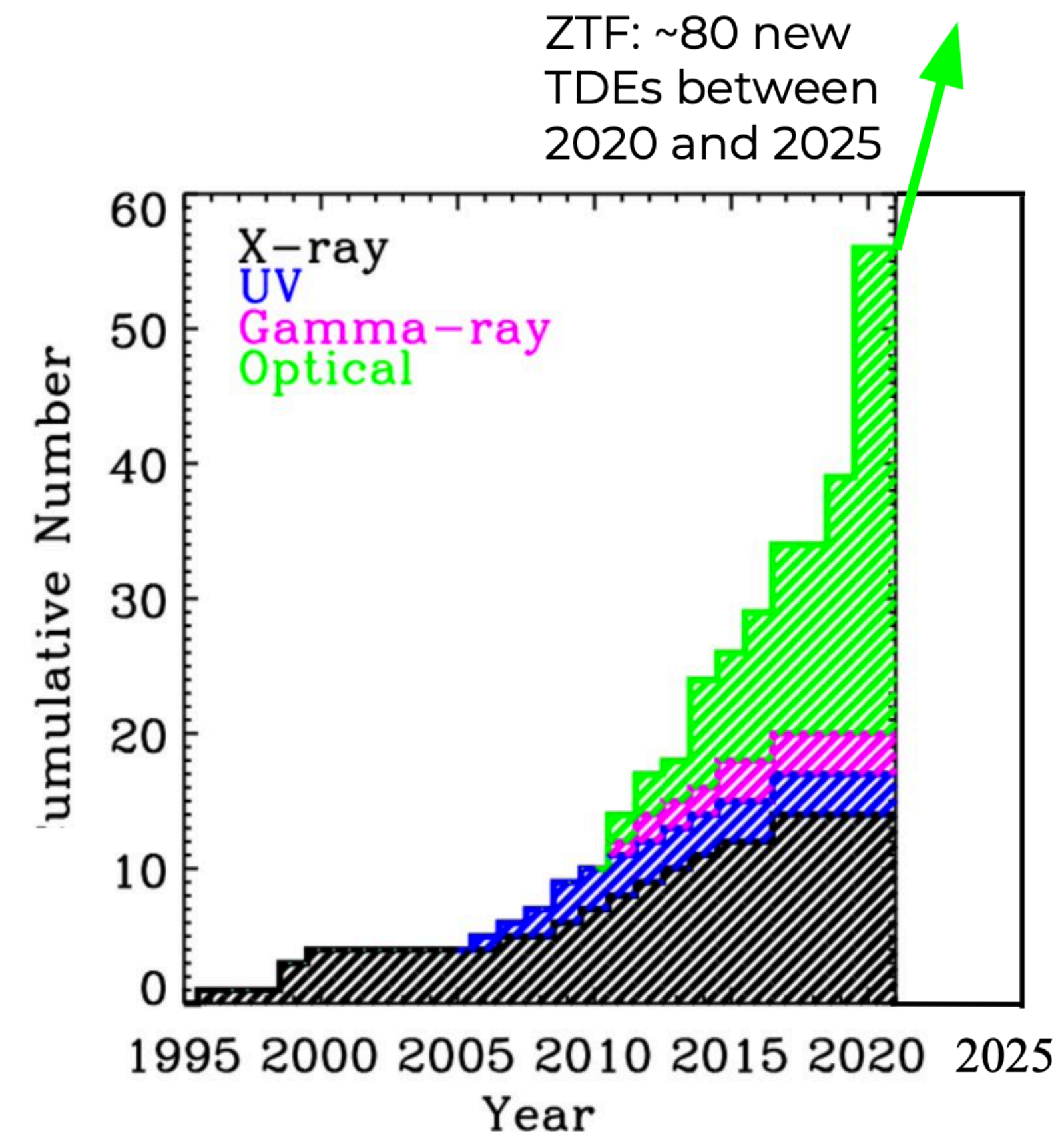
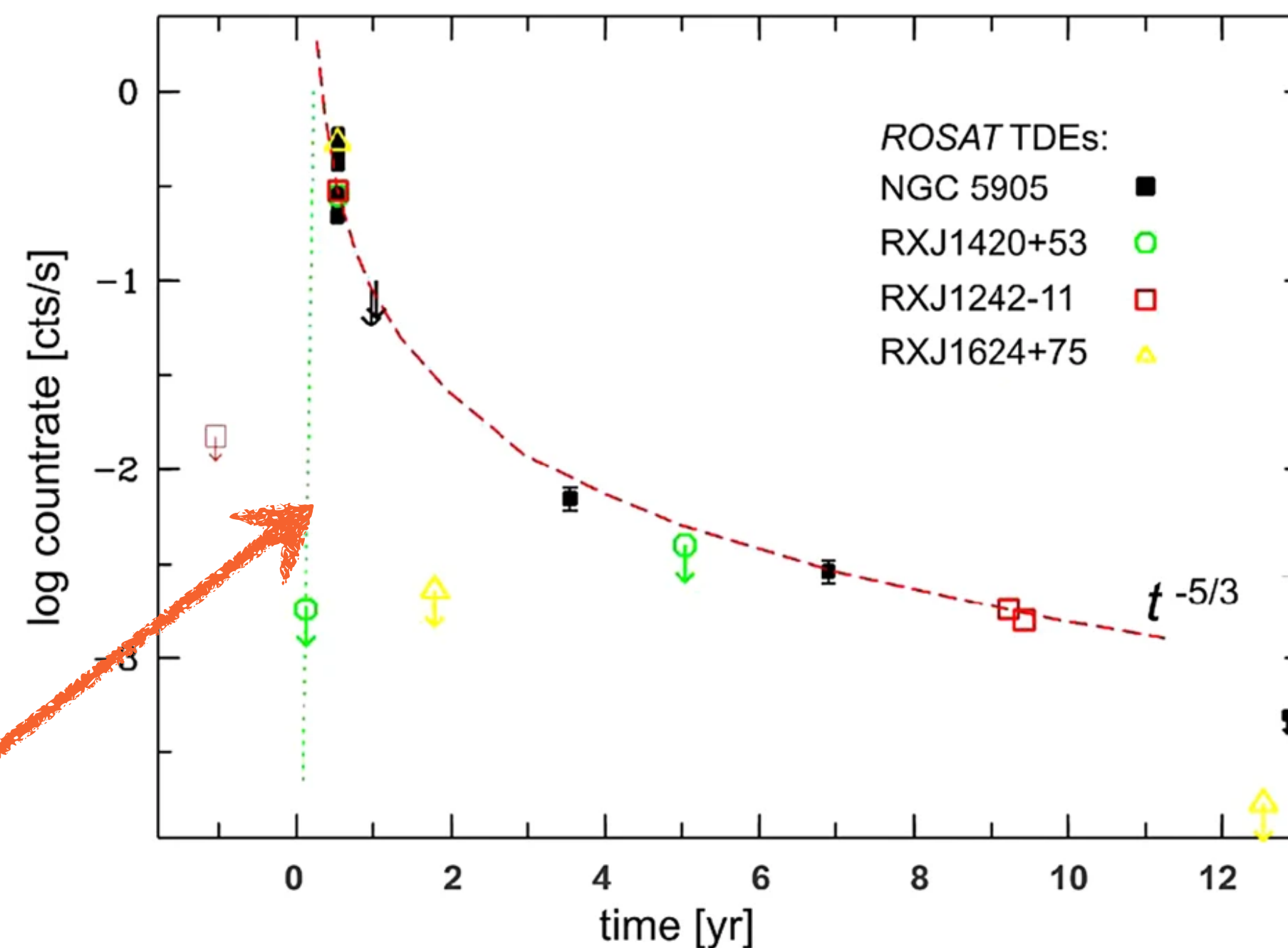
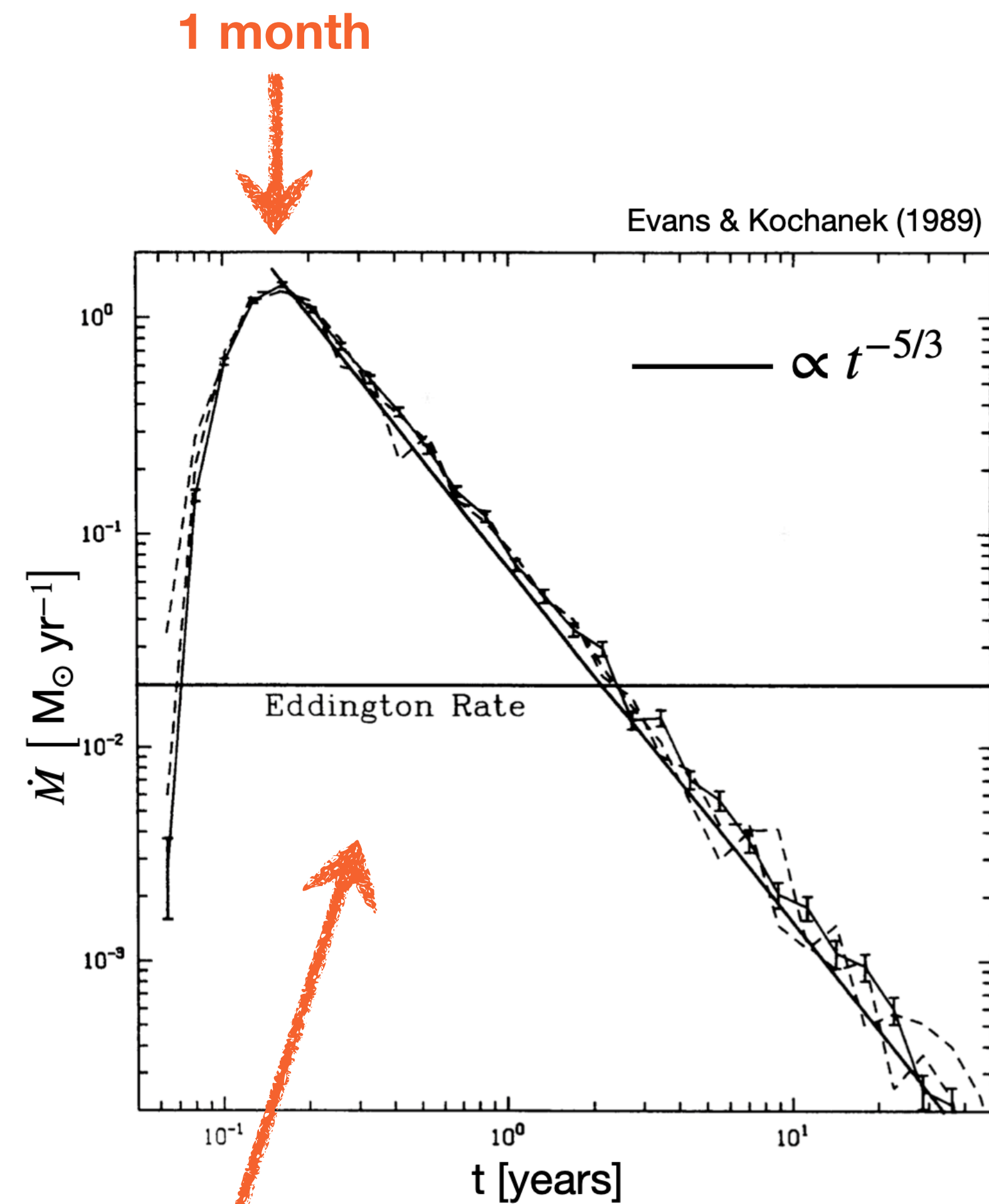

Tidal Disruption Events

Disruption of a star on its passage near SMBH

- mostly in quiescent post-starburst galaxies
- rate $\sim 10^{-4}$ / galaxy / year

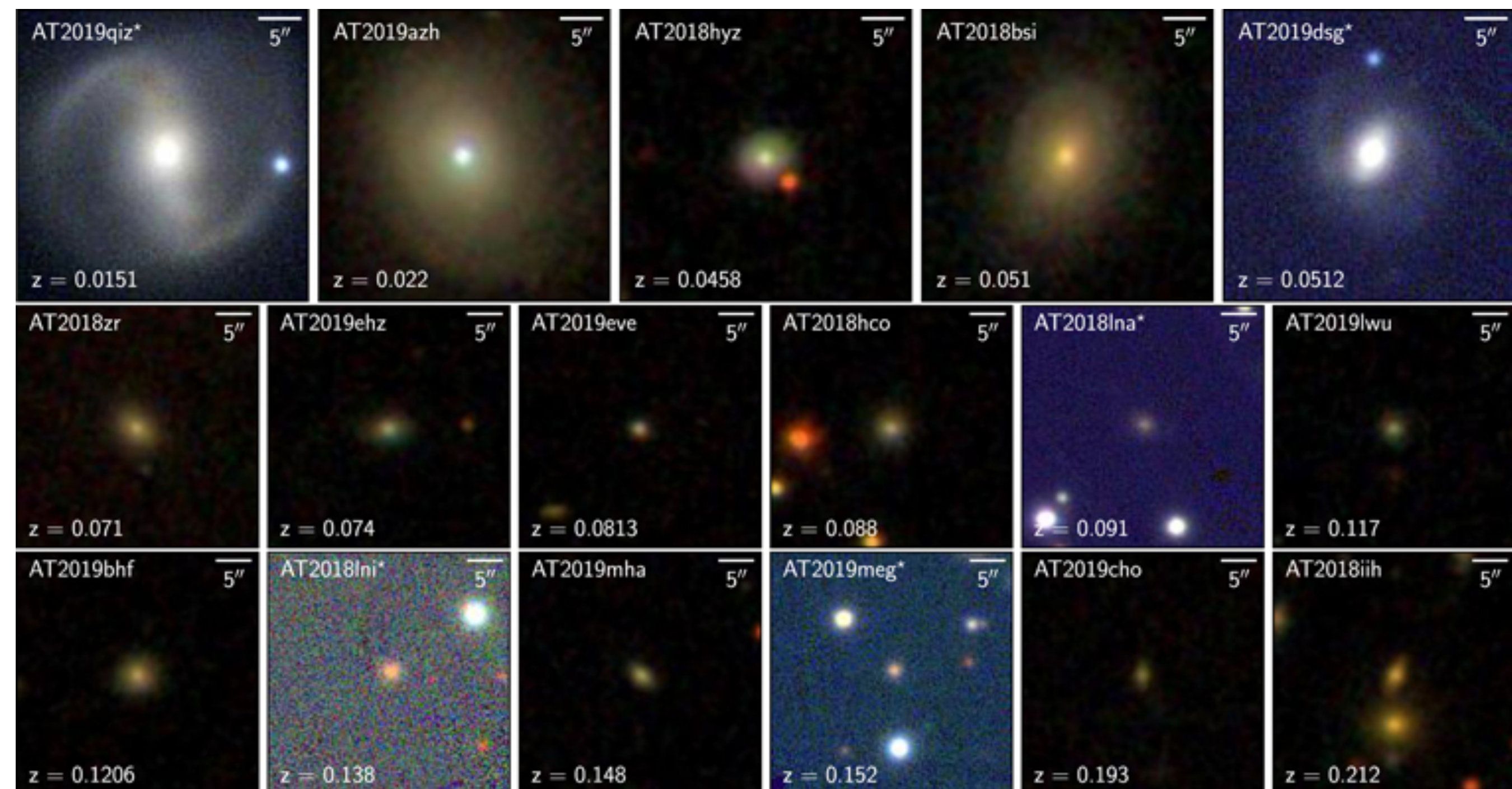
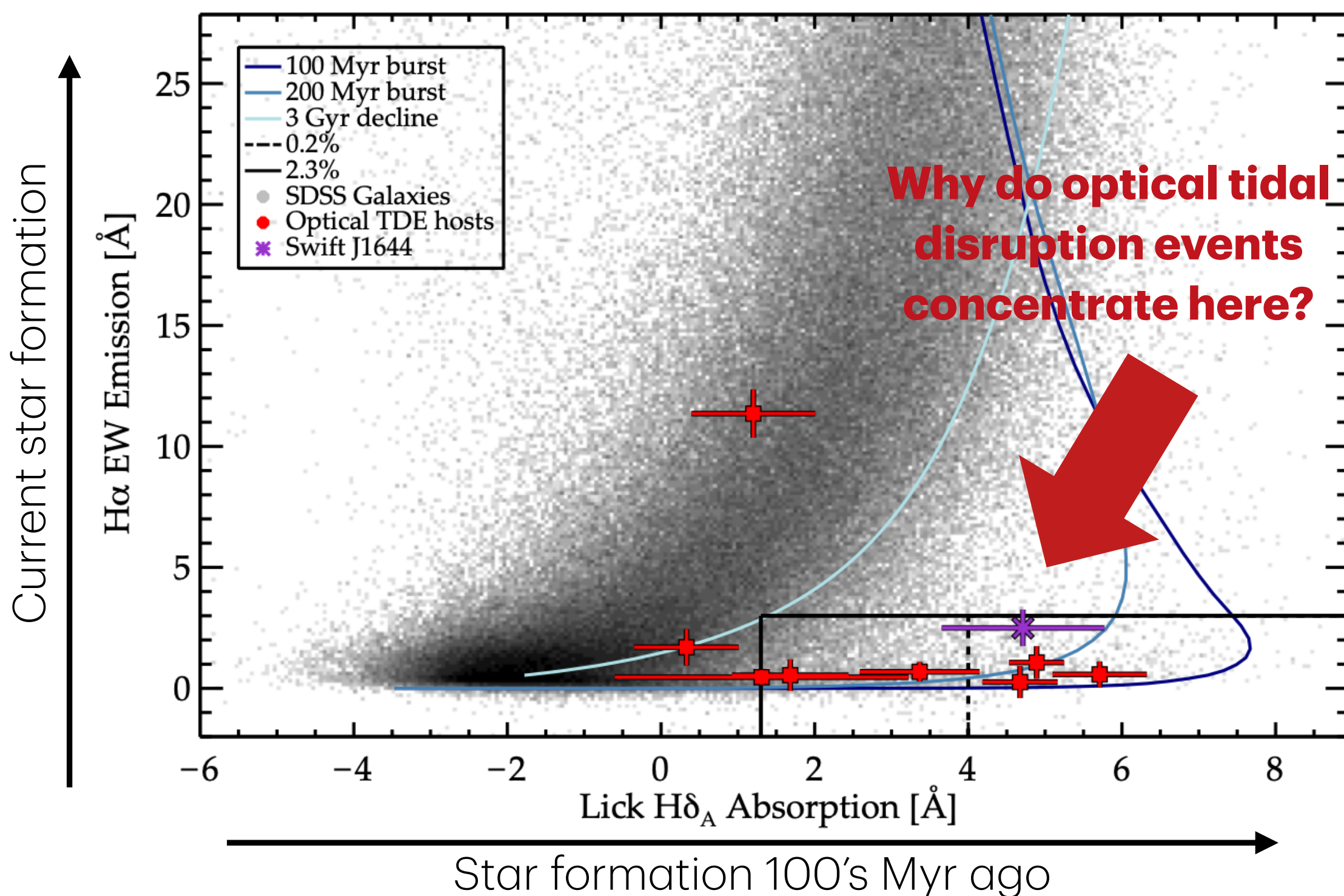

Tidal Disruption Events

(partial) Disruption of a star on its passage near SMBH

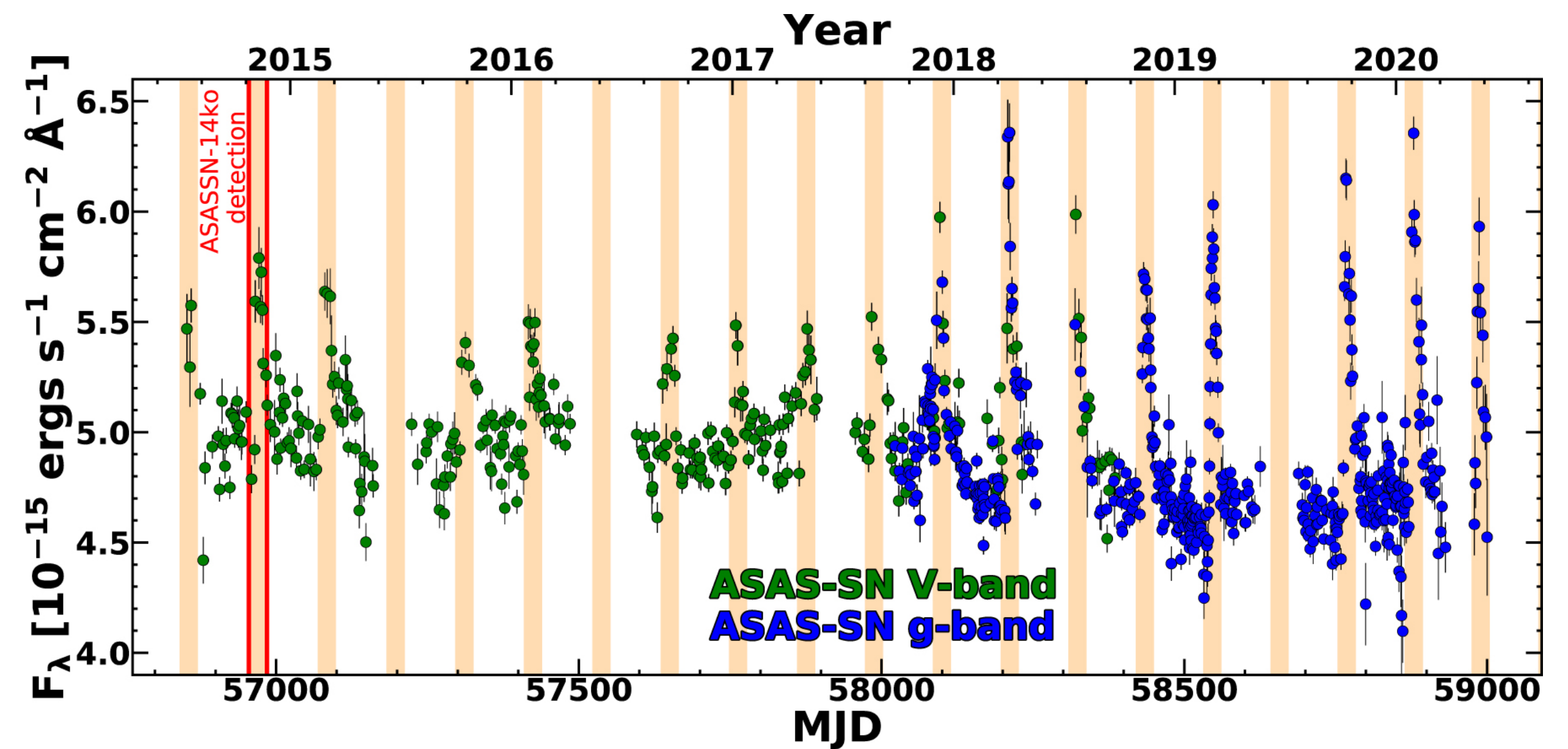
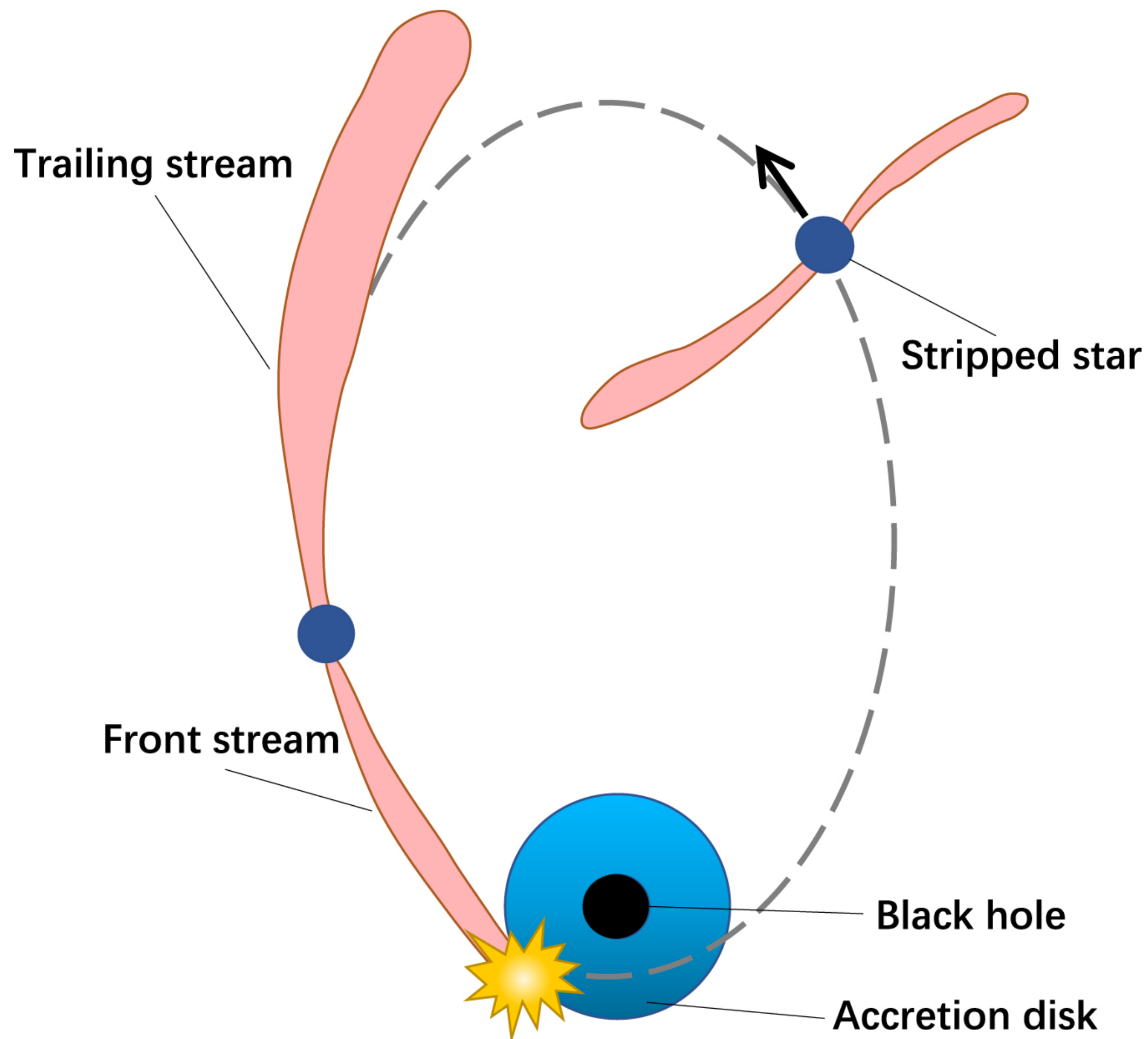

ASAS-SN 14ko: 114-day period, decreasing with time

Tidal Disruption Events

(partial) Disruption of a star on its passage near SMBH

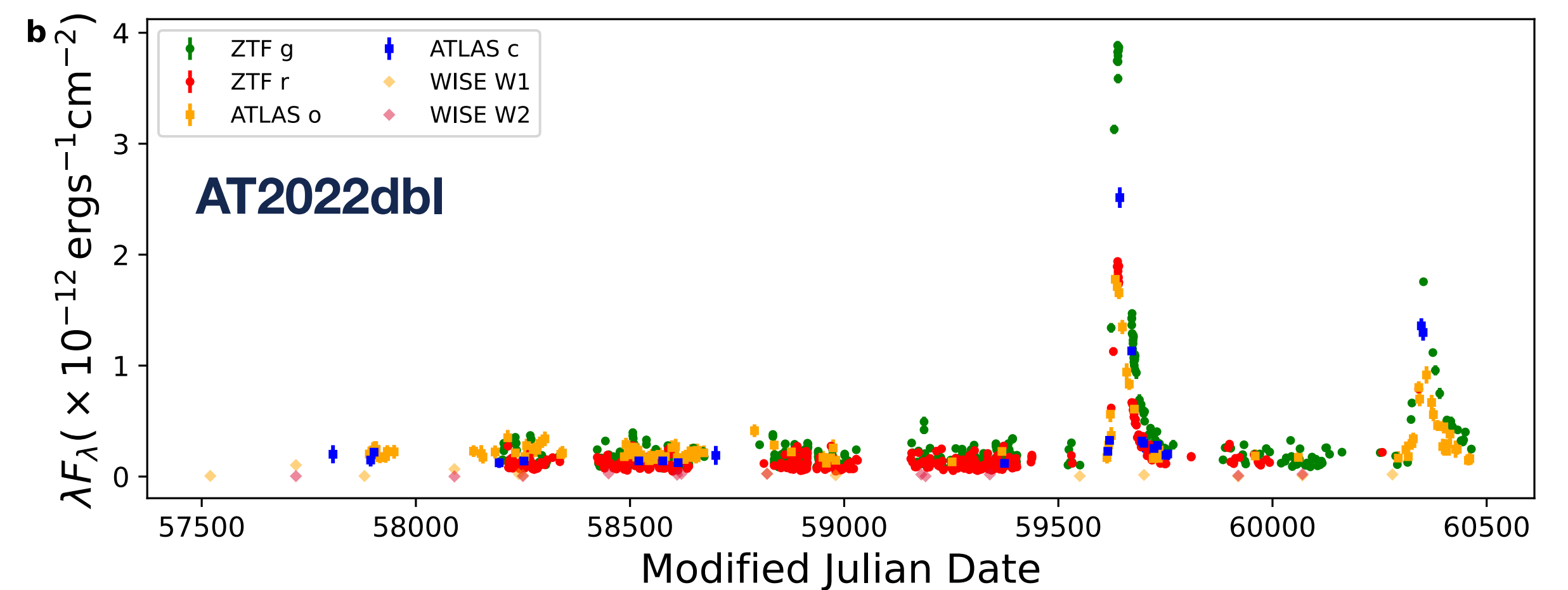
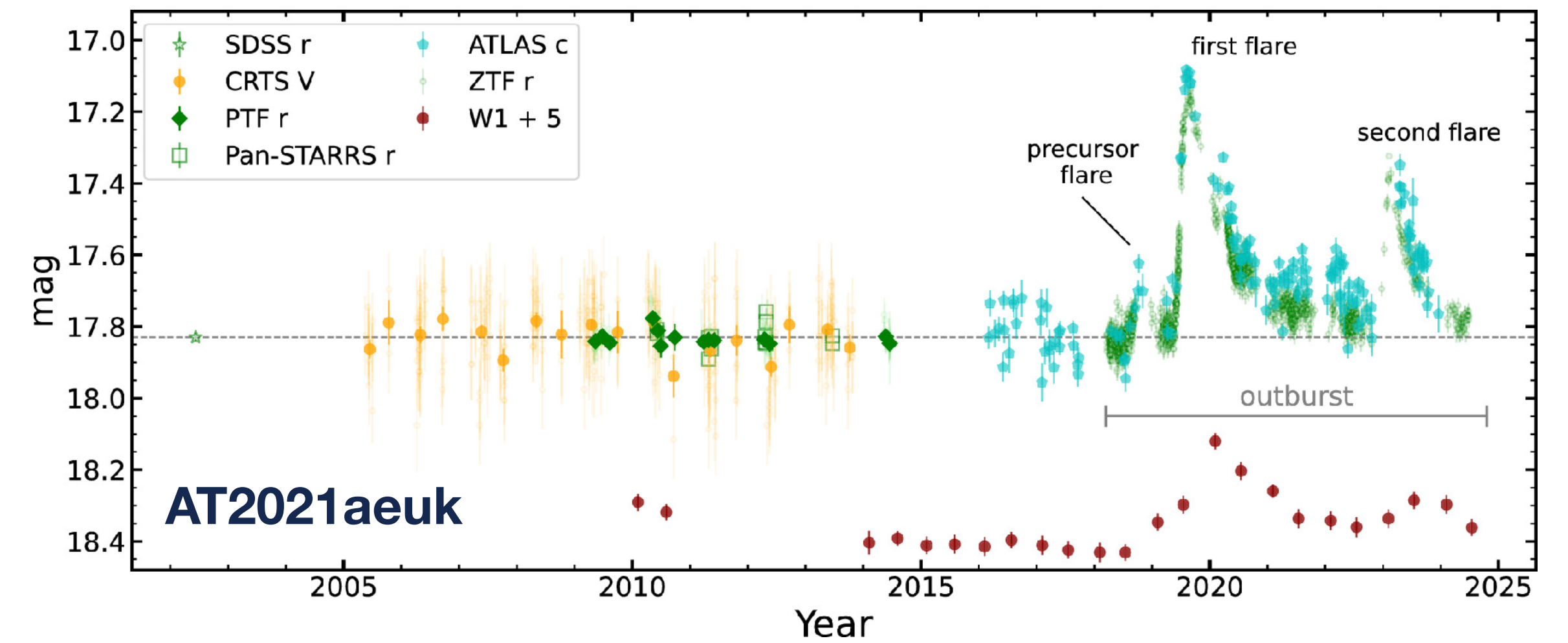
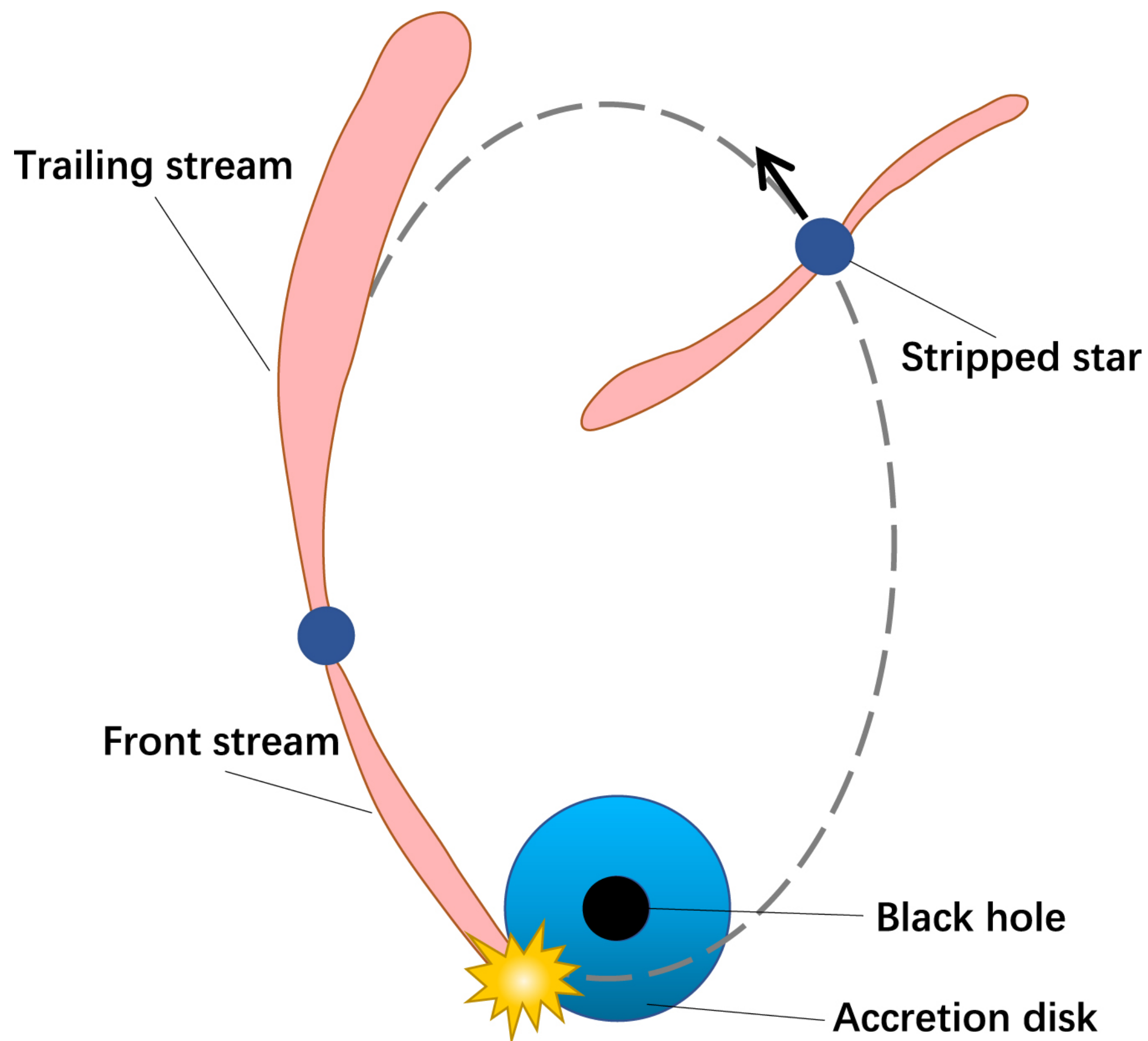

Tidal Disruption Events

(partial) Disruption of a star on its passage near massive BH

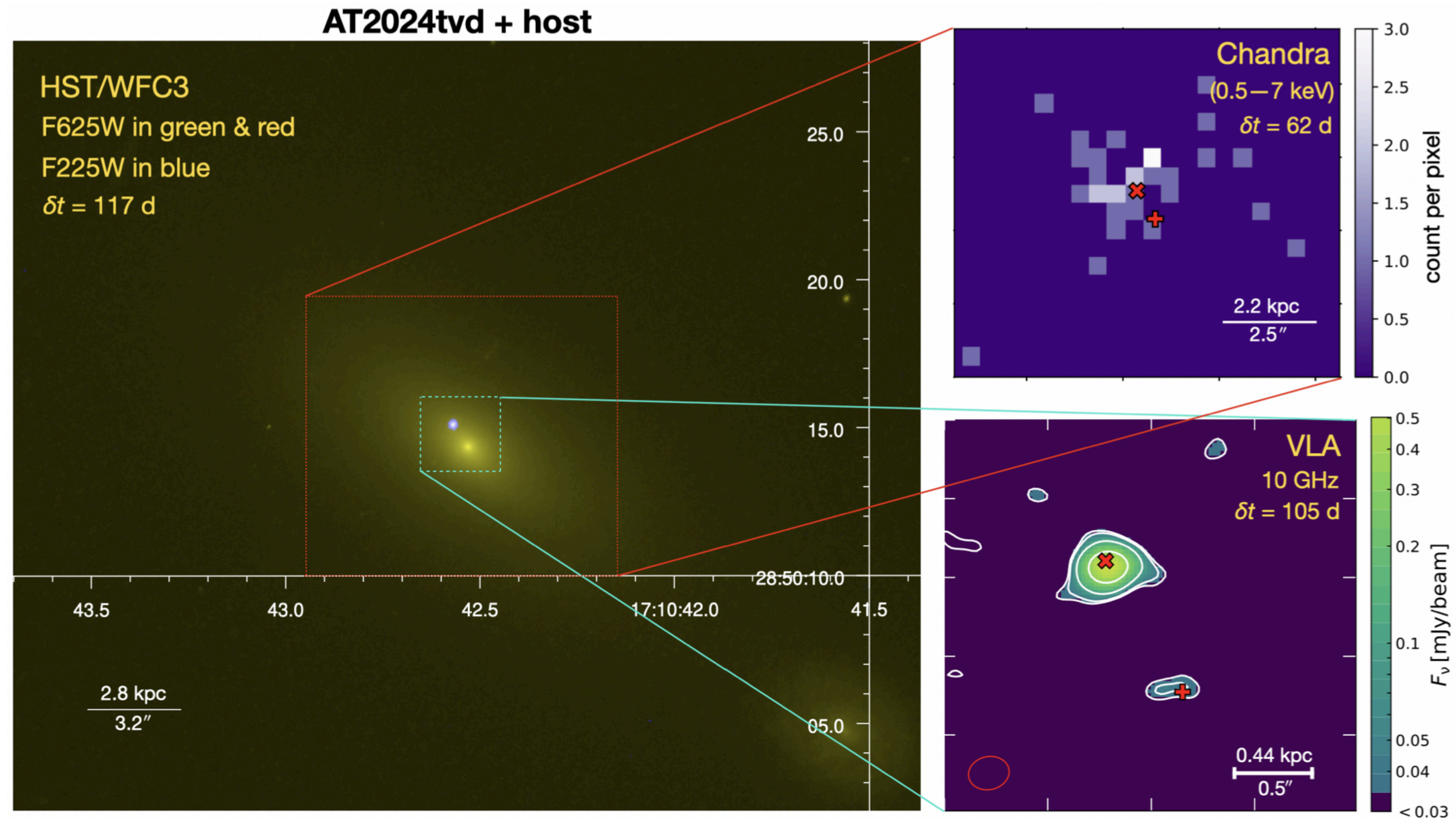
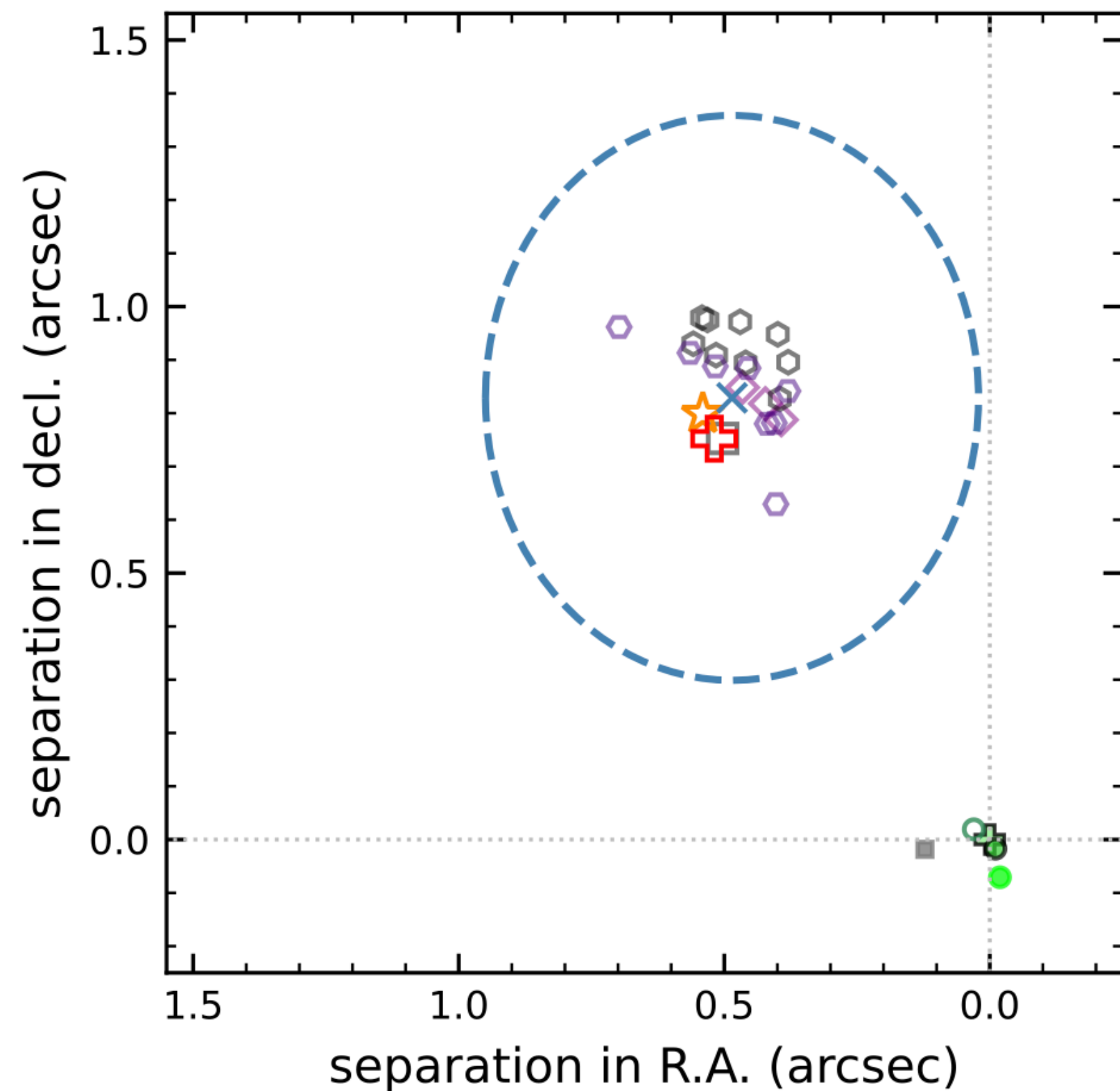
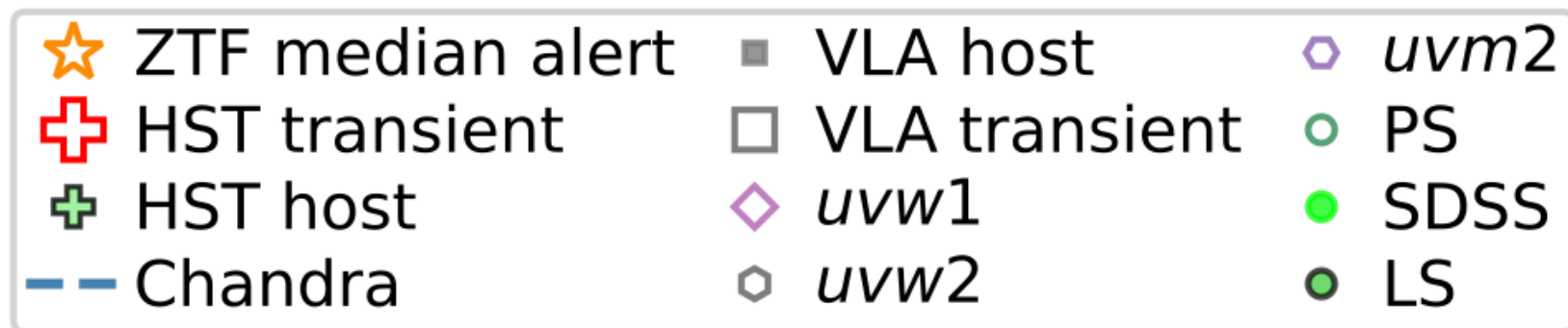

...also in active galaxies

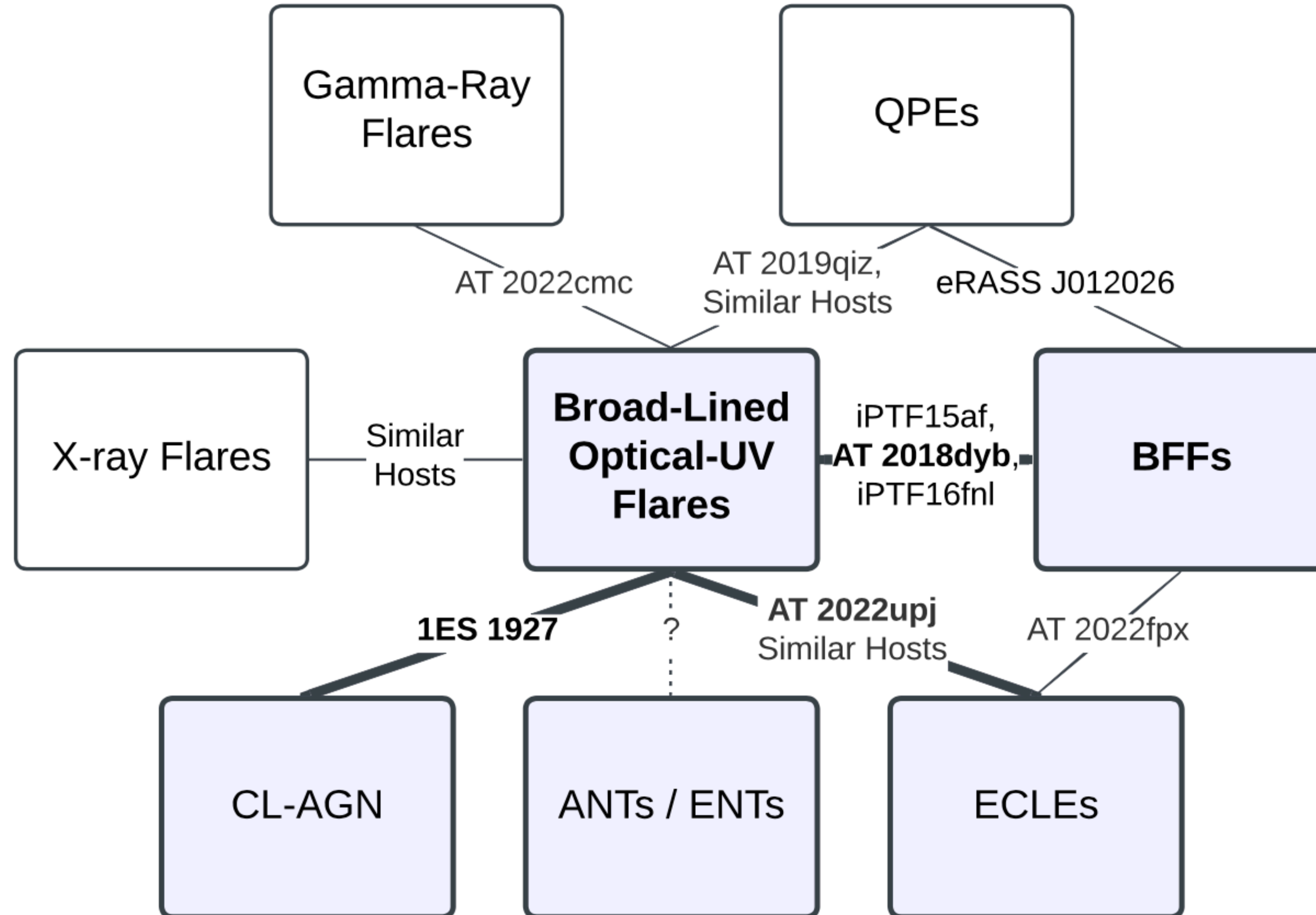

How to find TDEs?

1. Photometric properties

- Color
- Shape
- Amplitude

3. Context information

- Nuclear
- Green valley
- Low-mass passive host
- Multi-wavelength information

2. Spectroscopic properties

- Broad lines
- H/He/H+He/Featureless
- Possible: ECLE / Bowen

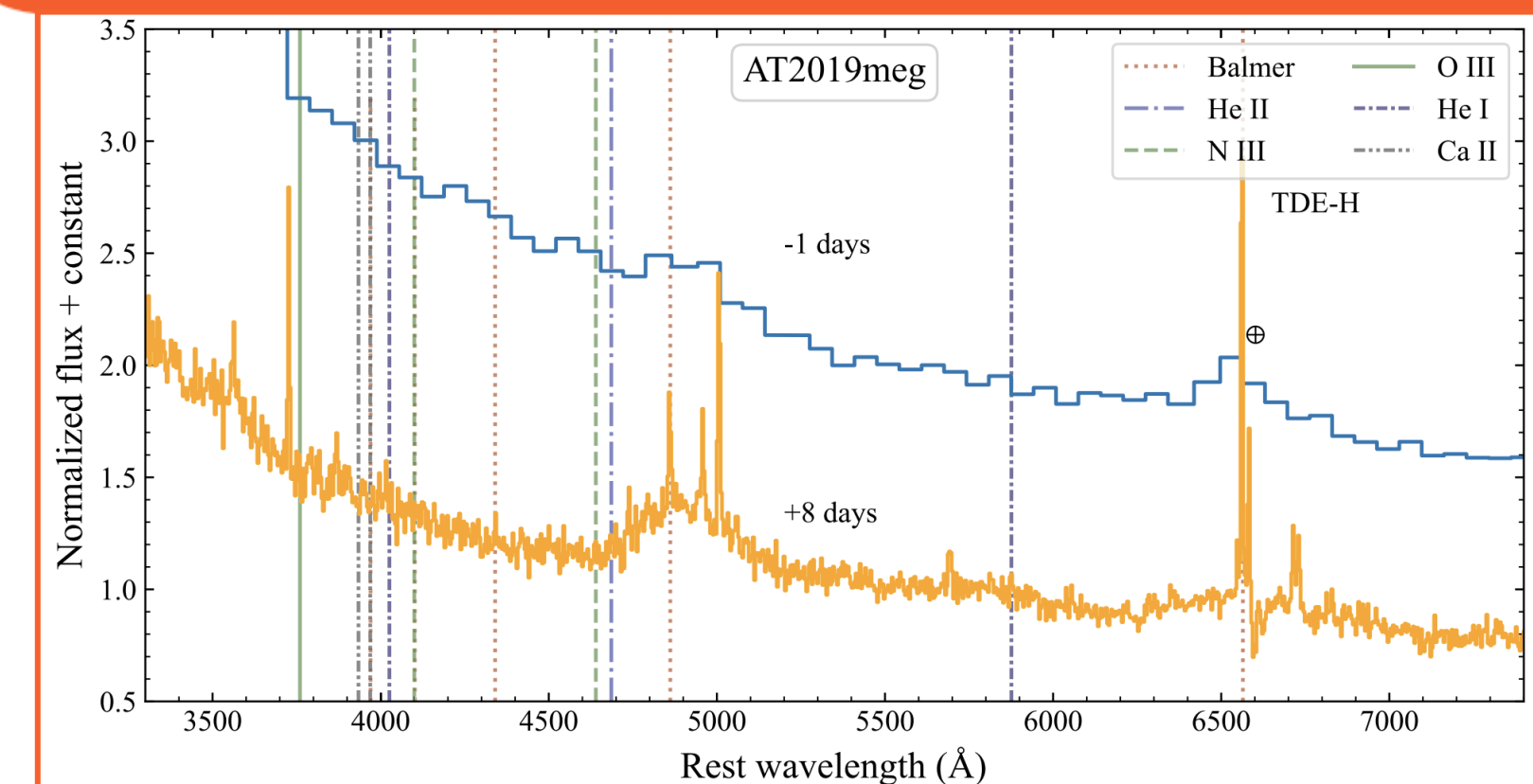

Photometric properties

~150 known TDEs

- Nuclear transients
- ~30 day rise
- $t^{-5/3}$ decay
- High temperature
- Constant temperature
- $M \sim -17$ to -20
- Possibly repeating

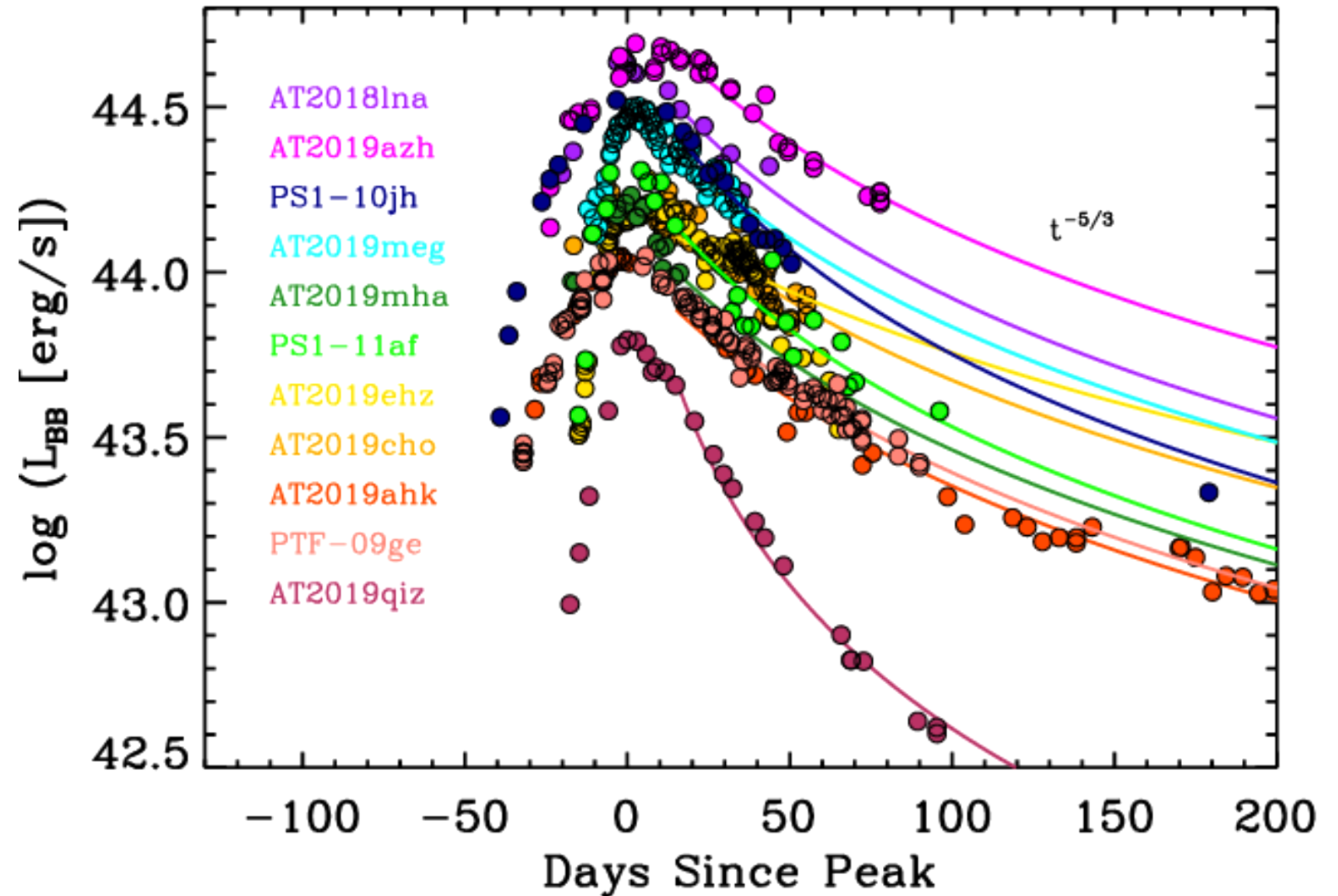

Photometric properties

~150 known TDEs

- Nuclear transients
- ~30 day rise
- ~~$t^{-5/3}$ decay~~
- High temperature
- ~~Constant temperature~~
- ~~$M \sim -17$ to -20~~
- Possibly repeating

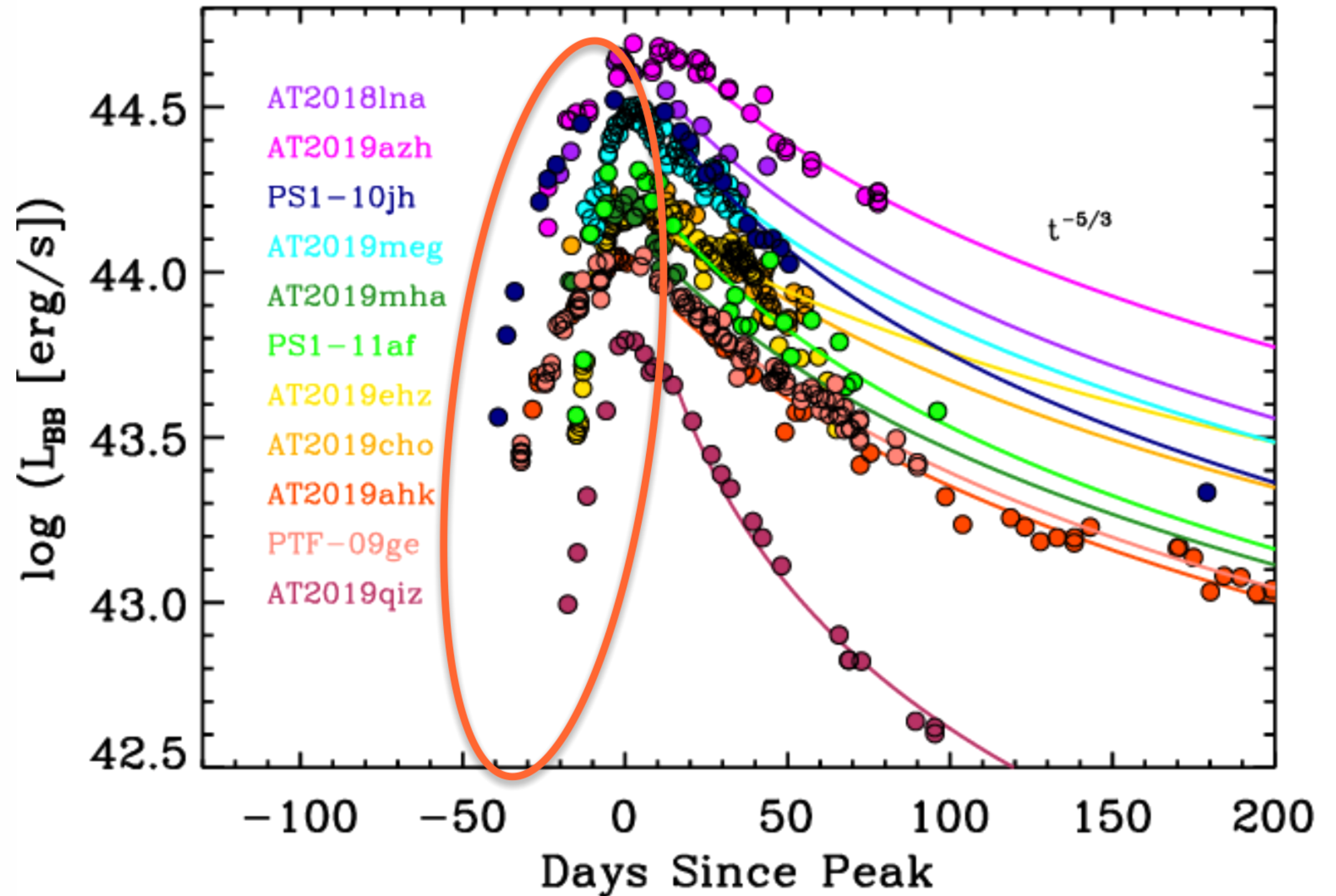

Early TDE module

- Rising parts of the light curves
- Parametric feature extraction
 - Rainbow fit: constant temperature, sigmoid shape
- Trained on historical ZTF data
 - 42 TDEs only, ~9k non-TDEs
- Deployed in late 2025
 - Slack and Telegram bots

A&A, 705, A144 (2026)
<https://doi.org/10.1051/0004-6361/202556558>
© The Authors 2026

**Astronomy
&
Astrophysics**

Early identification of optical tidal disruption events

A science module for the Fink broker

M. Llamas Lanza^{1,*,**}, S. Karpov^{2,*,**}, E. Russeil³, E. Quintin⁴, E. E. O. Ishida⁵, J. Peloton⁶,
M. V. Pruzhinskaya⁷, and A. Möller^{8,9}

¹ IRAP, Université de Toulouse, CNRS, CNES, UPS, Toulouse, France

² Institute of Physics of the Czech Academy of Sciences, Na Slovance 1999/2, 182 00 Prague 8, Czech Republic

³ The Oskar Klein Centre, Department of Astronomy, Stockholm University, AlbaNova, SE-10691 Stockholm, Sweden

⁴ European Space Agency (ESA), European Space Astronomy Centre (ESAC), Camino Bajo del Castillo s/n, 28692 Villanueva de la Cañada, Madrid, Spain

⁵ Université Clermont Auvergne, CNRS, LPCA, Clermont-Ferrand F-63000, France

⁶ Université Paris-Saclay, CNRS/IN2P3, IJCLab, Orsay, France

⁷ Lomonosov Moscow State University, Sternberg Astronomical Institute, Universitetsky 13, Moscow 119234, Russia

⁸ Centre for Astrophysics and Supercomputing, Swinburne University of Technology, Mail Number H29, PO Box 218, 31122 Hawthorn, VIC, Australia

⁹ ARC Centre of Excellence for Gravitational Wave Discovery (OzGrav), John St, Hawthorn, VIC 3122, Australia

Received 23 July 2025 / Accepted 20 November 2025

ABSTRACT

Context. The detection of tidal disruption events (TDEs) is one of the key science goals of large optical time-domain surveys such as the *Zwicky* Transient Facility (ZTF) and the upcoming *Vera C. Rubin* Observatory Legacy Survey of Space and Time. Automated and reliable classification pipelines that can select promising candidates in real time are required to identify TDEs in the vast alert streams produced by these surveys, however.

Aims. We developed a module within the FINK alert broker to identify TDEs during their rising phase. The module was built to autonomously operate within the ZTF alert stream and to produce a list of candidates every night, enabling spectral and multiwavelength follow-up near peak brightness.

Methods. All rising alerts were submitted to selection cuts and feature extraction using the RAINBOW multiband light-curve fit. Best-fit values were used as input to train an XGBoost classifier with the goal of identifying TDEs. The training set was constructed using ZTF observations for objects with available classification in the Transient Name Server. Finally, candidates for which the probability was high enough were inspected visually.

Results. The classifier achieved 76% recall, which indicates a strong performance in early-phase identification, despite the limited available information before the peak. Out of the known TDEs that passed the selection cuts, half were flagged as TDEs before they had risen half the way. This proves that an early classification is possible. Additionally, new candidates were identified by applying the classifier on archival data, including a likely repeated TDE and some potential TDEs that occurred in active galaxies. The module is implemented in the FINK alert-processing framework and each night reports a small number of candidates to dedicated communication channels through a user-friendly interface for manual vetting and potential follow-up.

Key words. black hole physics – methods: data analysis – techniques: photometric – surveys

Rising parts of light curves: selection and fitting

- 100 days long window for analysis
- at least 5 points, in both filters
- no detections in 100 days before
- no negative detections prior to that
- rising in both bands
 - last point is above minimum, or
 - significantly positive slope
- not fading in both bands
 - last point is not below maximum
 - every point is not below preceding one

Parametric Rainbow fit (Russeil et al. 2024)

sigmoid rise + constant temperature

4 parameters:

position, scale, amplitude, temperature

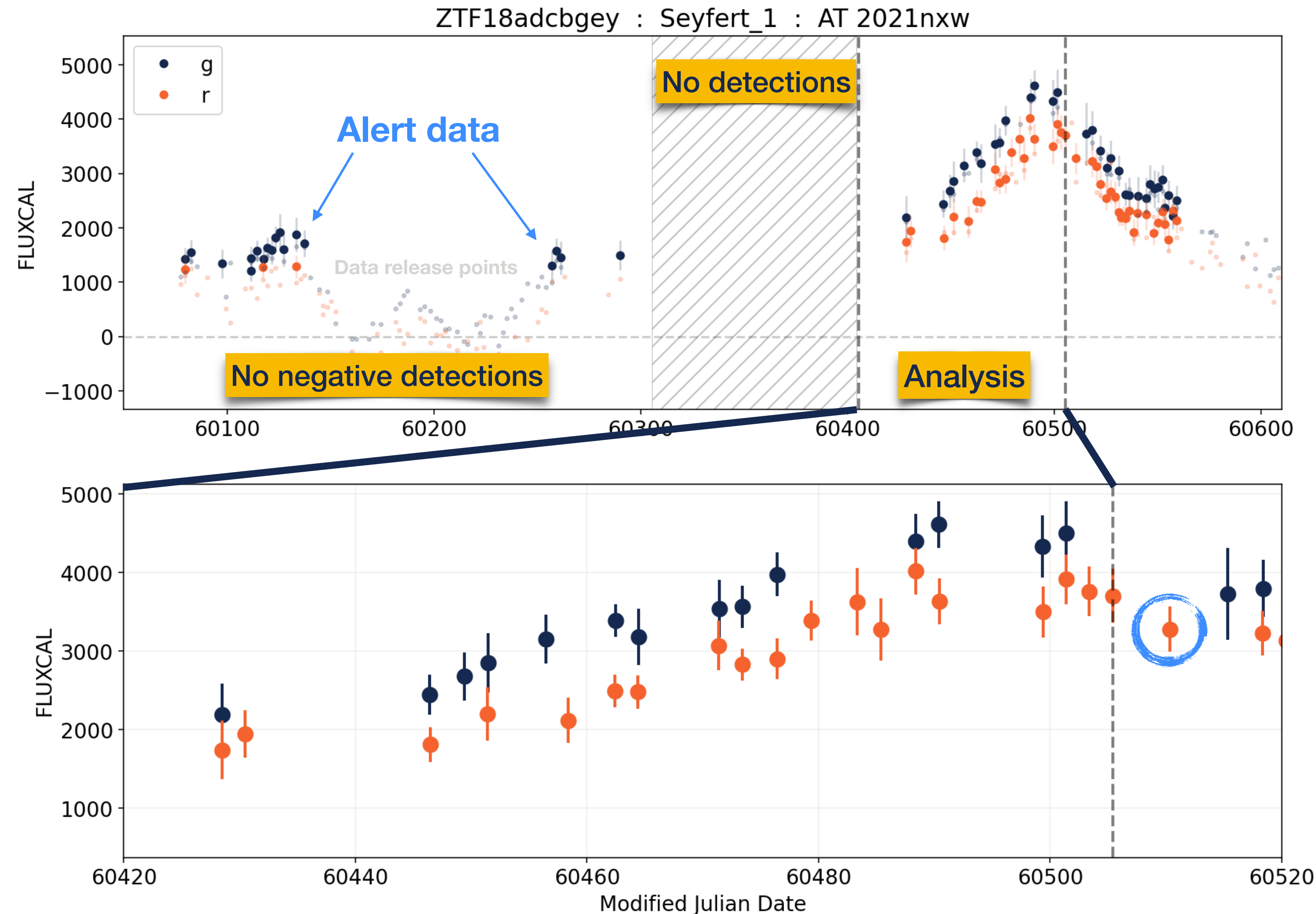

Training sample: ZTF + TNS

- **~600k** light curves → **40k** peaks in total
- **8863** TNS entries
- **3956** SNe
- **42** TDEs



42 positives
8821 negatives

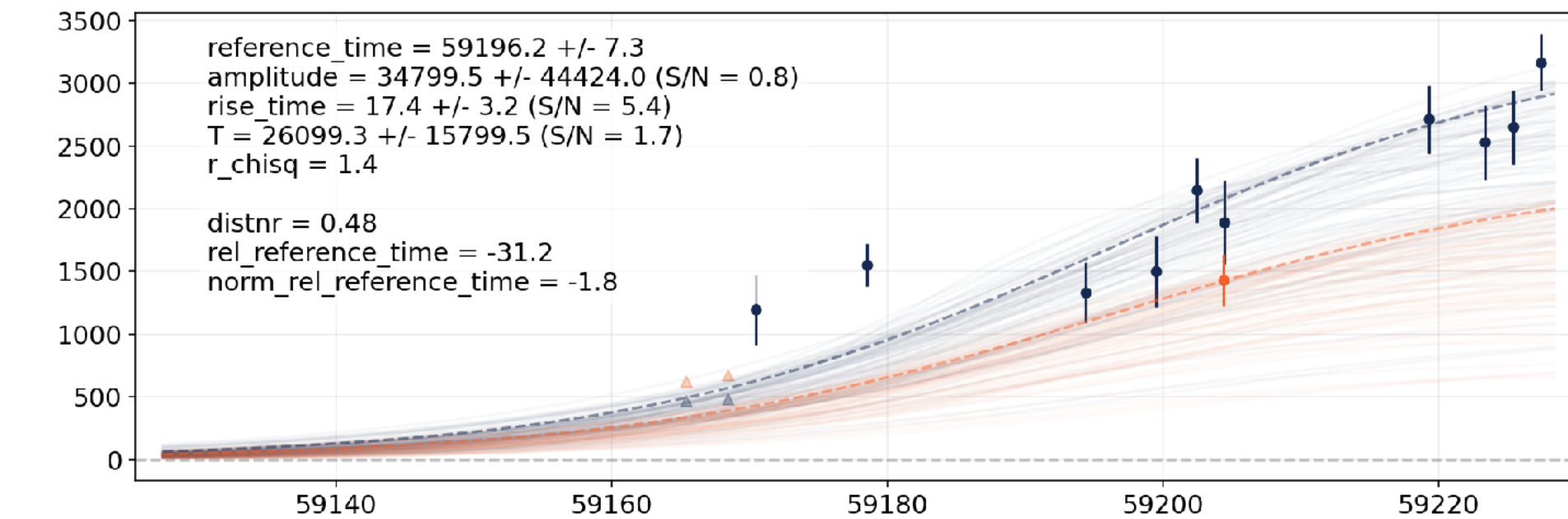
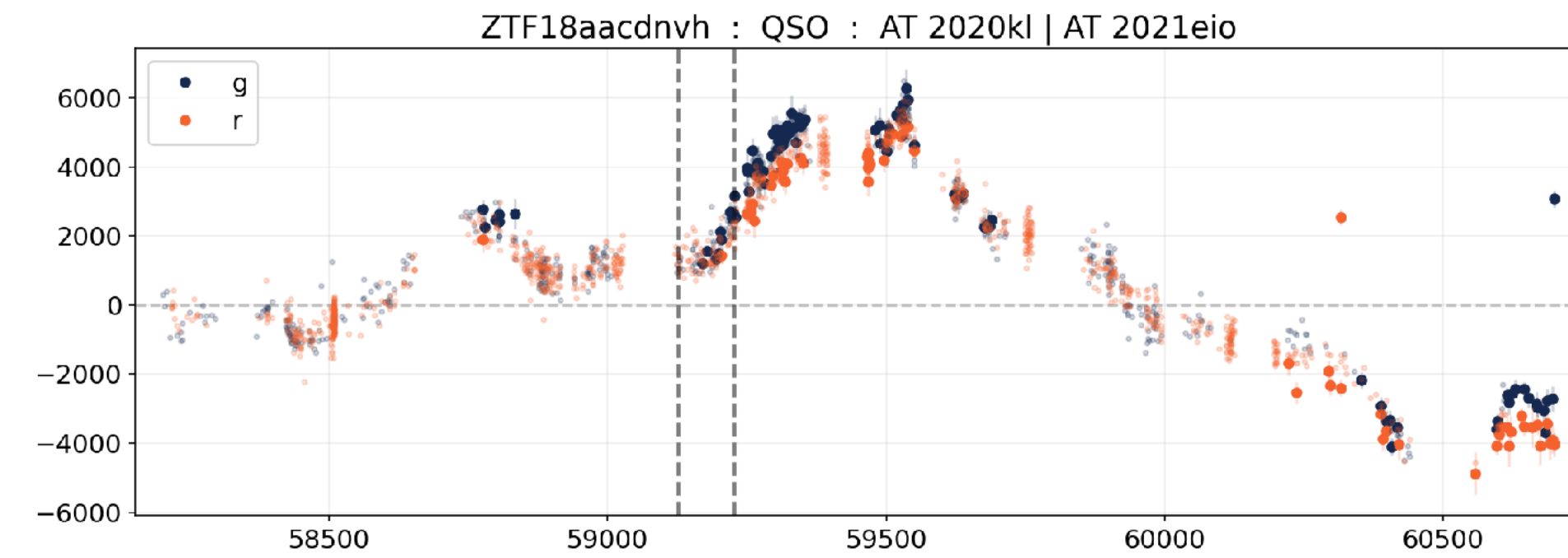
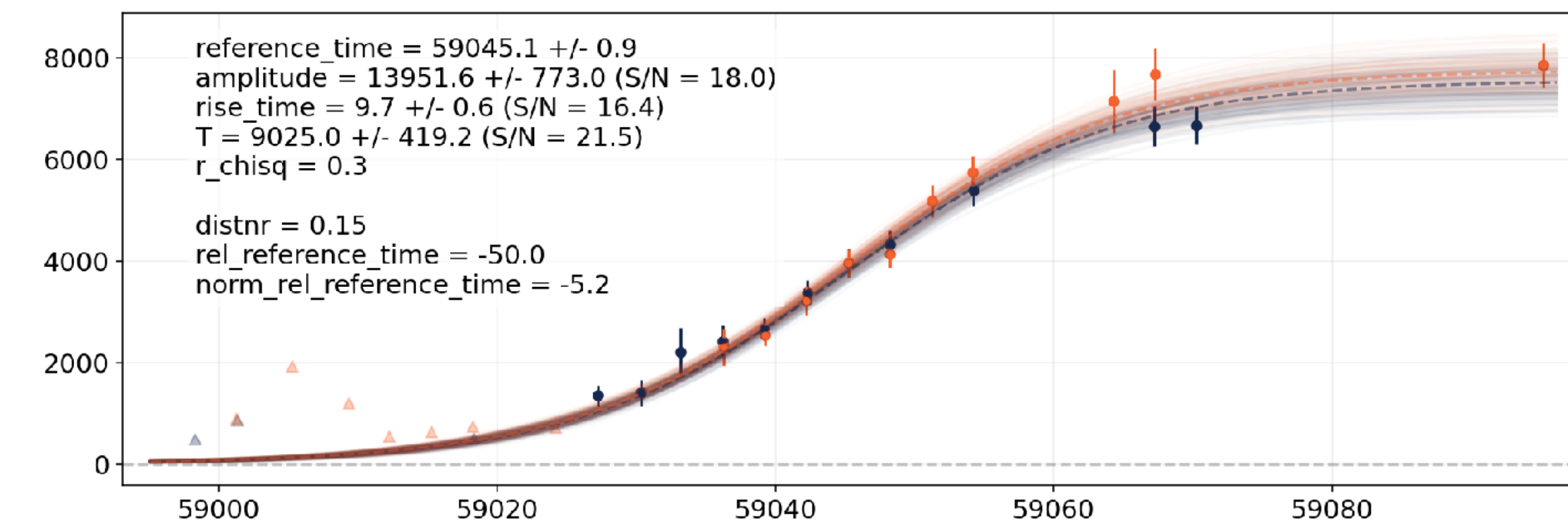
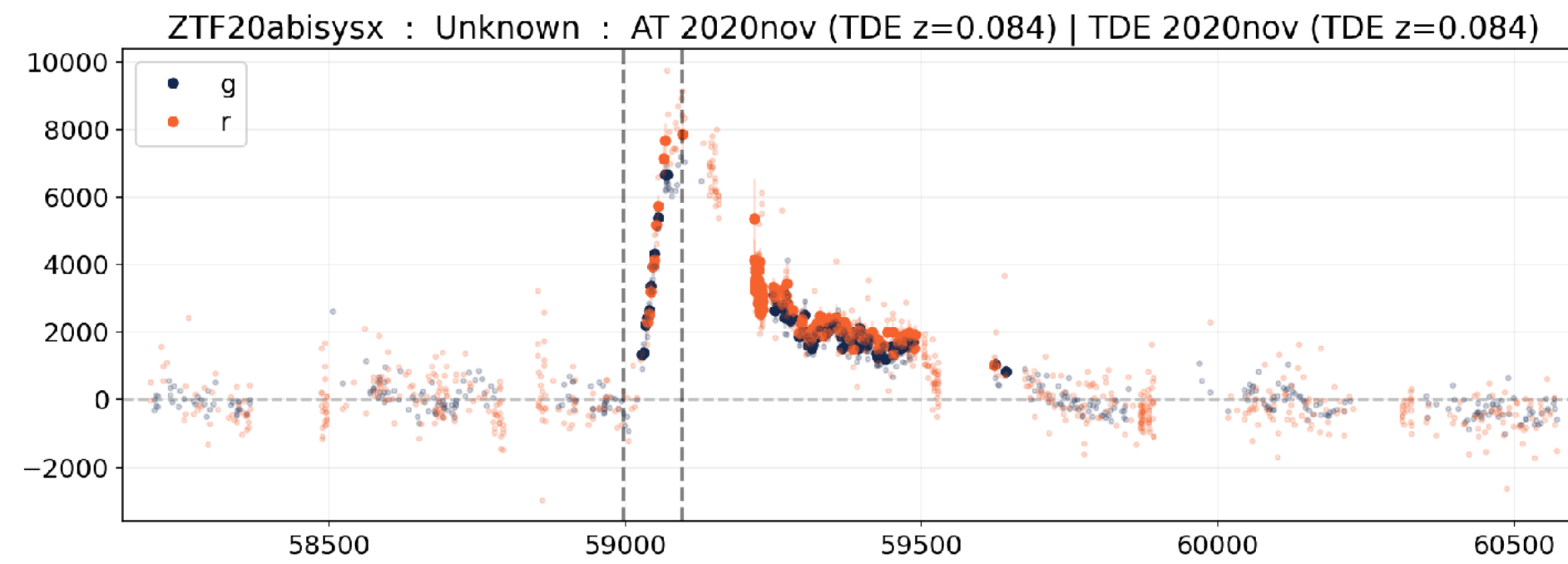
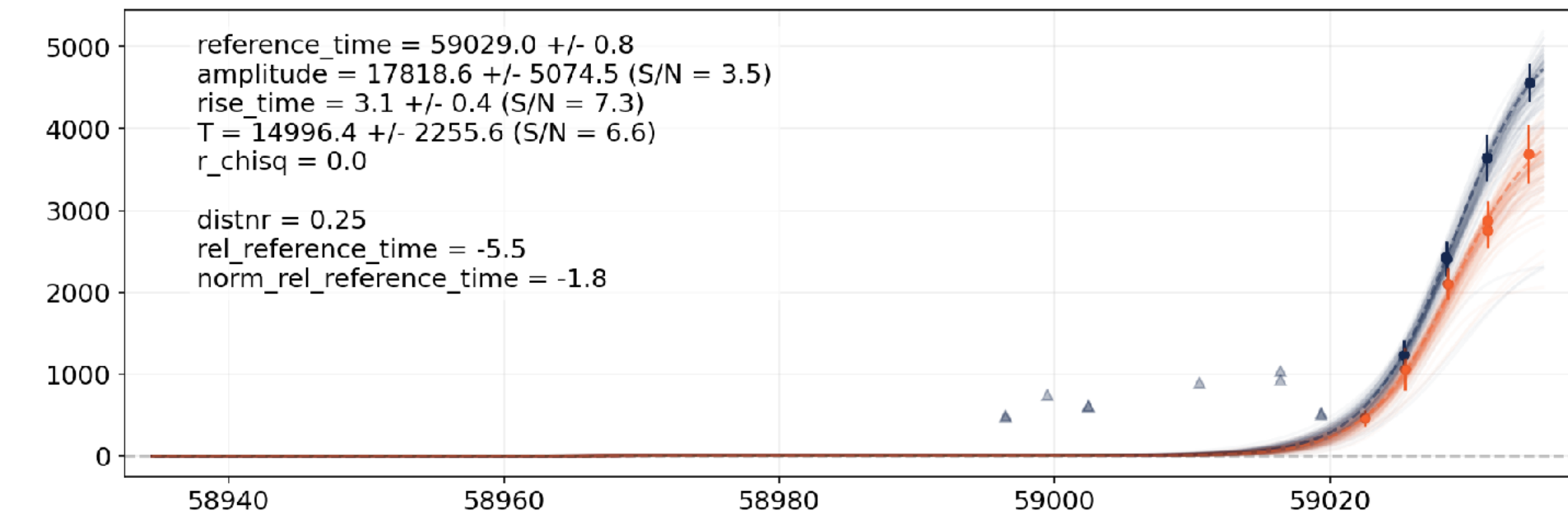
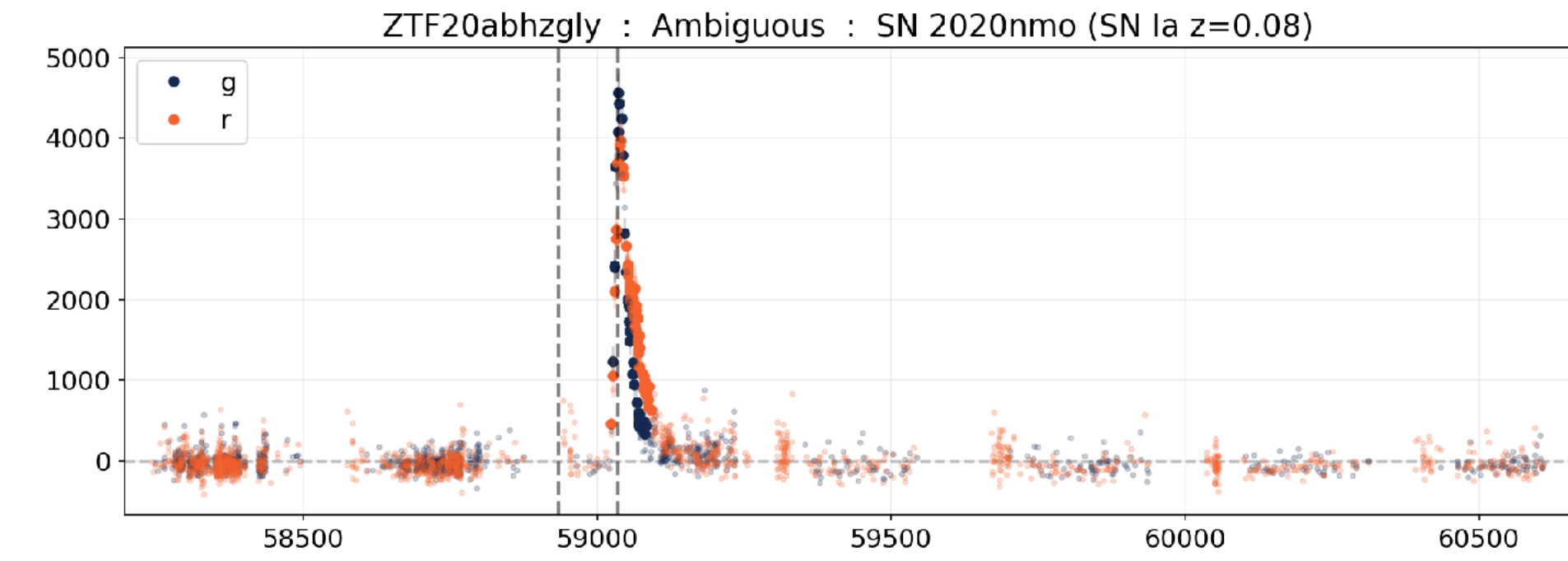

“Generalizing” classifier for heavily imbalanced data

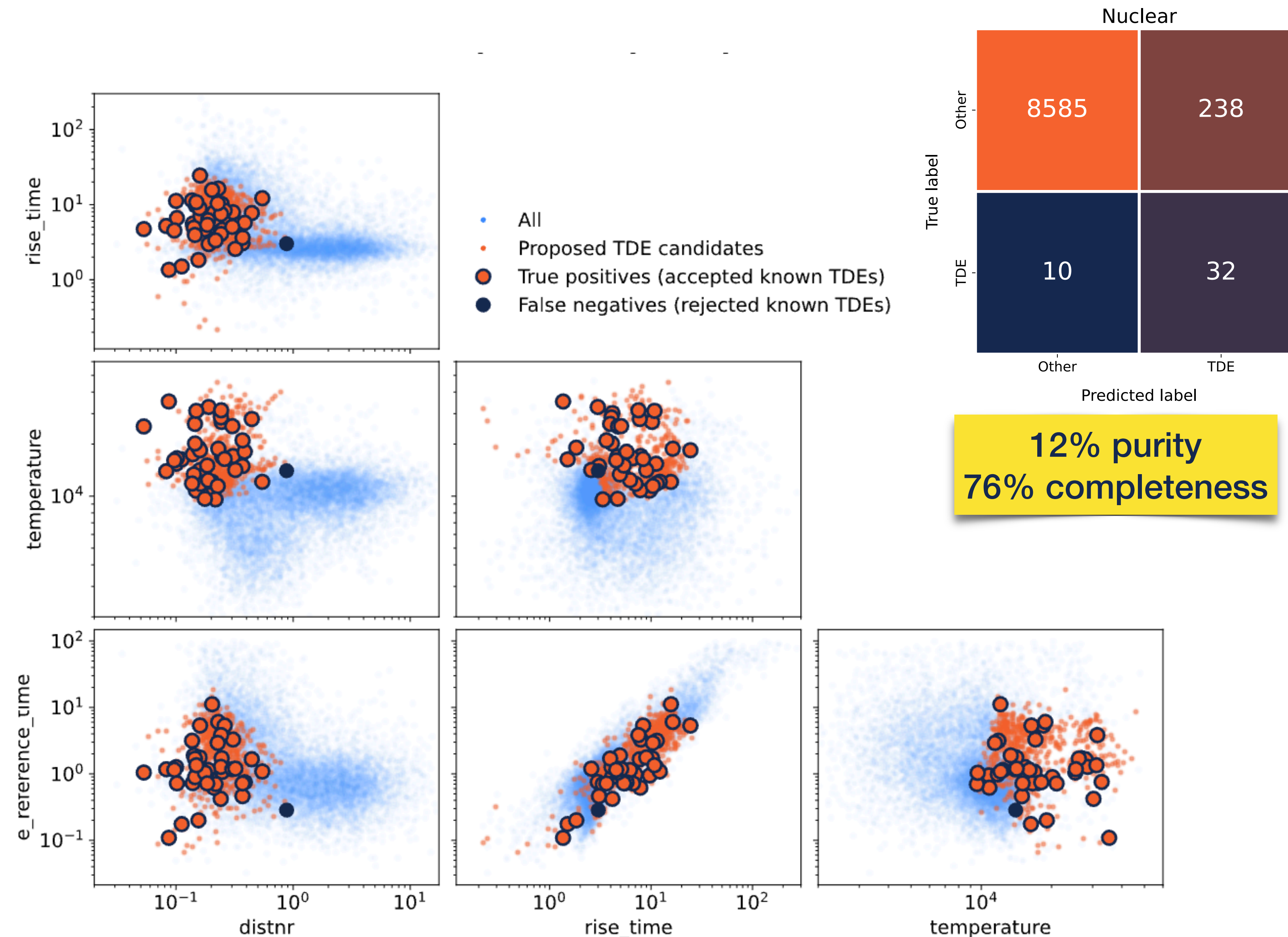

- XGBoost
- Balance by **two-step SMOTE**
- Force **shallow trees**
- Optimize hyperparameters for **recall**
 - use F2 score
- **Leave-One-Out** cross-validation

Name	Value	
	Nuclear	Broad
	Manually set	
max_depth	3	3
	Optimized for F2 score	
n_estimators	200	200
subsample	0.8	0.8
reg_lambda	1	1
reg_alpha	1	1
learning_rate	0.06	0.06
colsample_bytree	1.0	1.0
min_child_weight	5	5
	Final scores	
F2 score	0.37	0.25
F1 score	0.20	0.13
Precision	0.12	0.07
Recall	0.76	0.74

ZTF alert stream processing

- Processing of alerts after ZTF night ends
- Basic cuts on alert contents (up to 30 days)
- Cuts and Rainbow fits on complete light curves (~100 per night)
- Scores on best fits and random samples within fit covariances

~several candidates per night
not a proper Fink class!

- Fink Slack + public Telegram
- Light curve, Pan-STARRS cutout
- Classifier scores
- TNS / Fink classifications
- Links to Fink / TNS / SIMBAD / SNAD / VSX

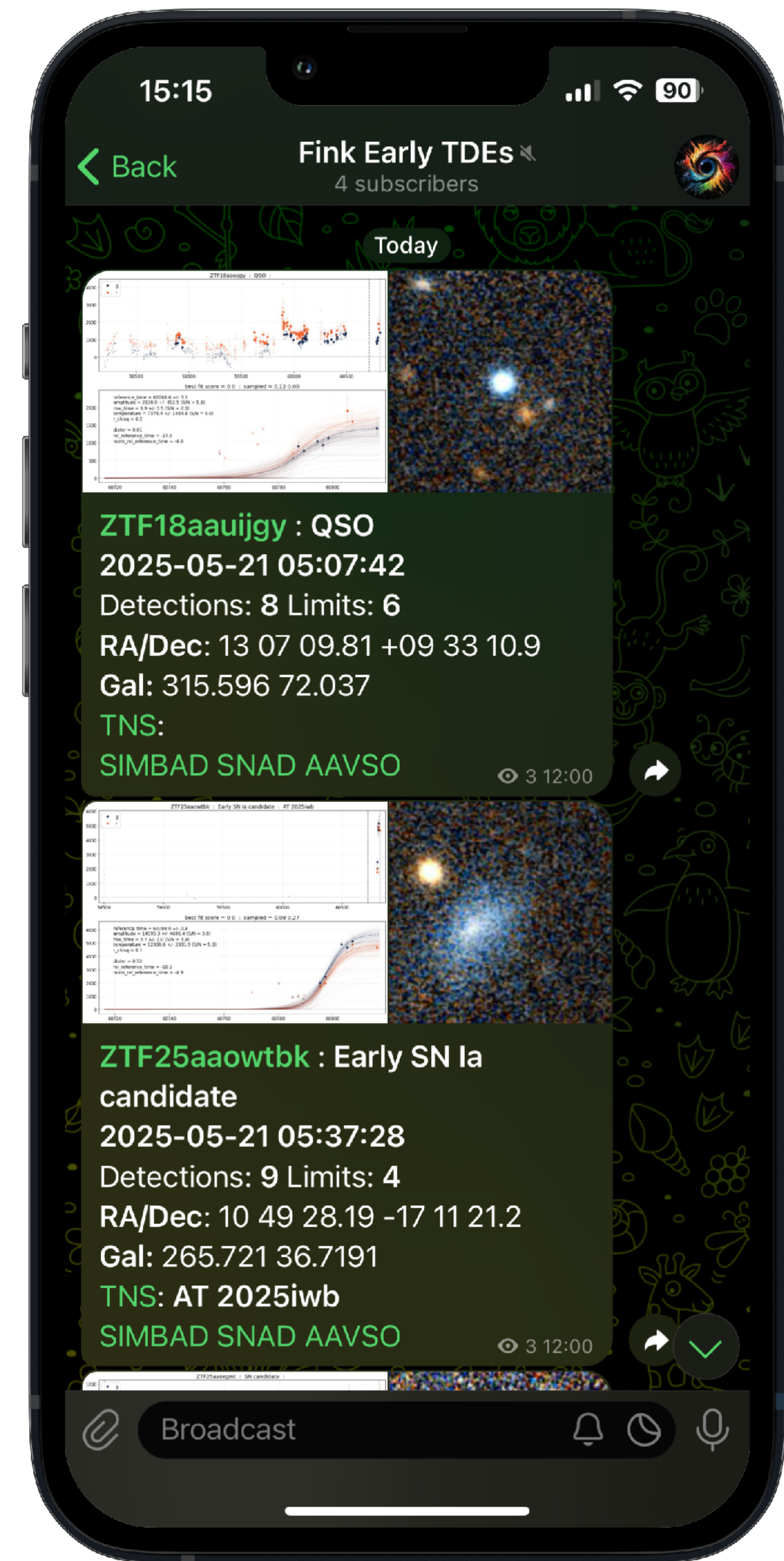
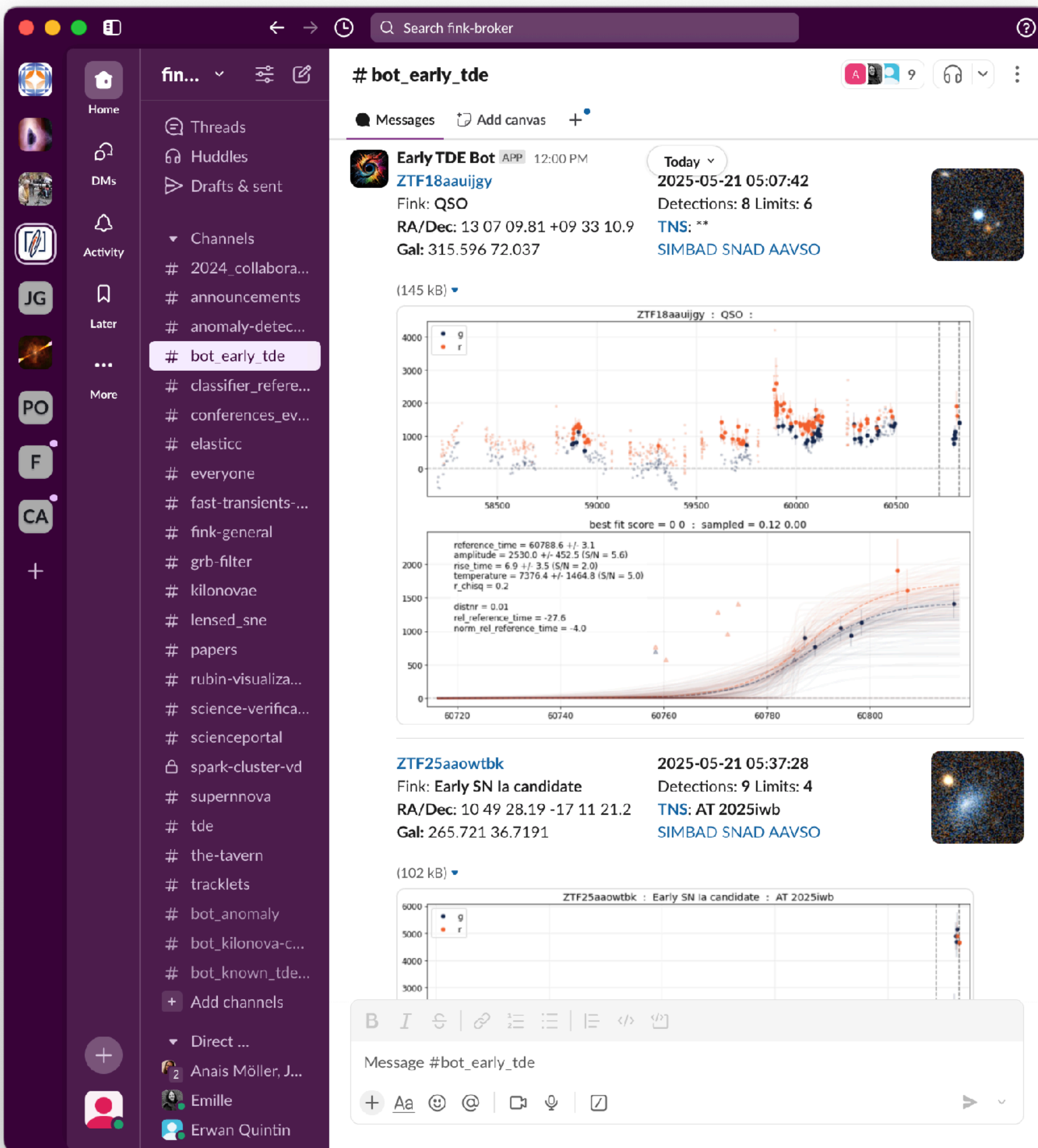

Looking for historical TDEs

Lost and found: A gallery of overlooked optical nuclear transients from the ZTF archive

E. Quintin¹, E. Russeil², M. Llamas Lanza³, S. Karpov⁴, E. E. O. Ishida⁵, J. Peloton⁶, M. V. Pruzhinskaya⁷, A. Möller^{8,9}, M. Giustini¹⁰, G. Miniutti¹⁰, R.S. Saxton¹¹, P. Sánchez-Sáez¹², S. Zheltoukhov⁷, A. Dodin⁷, and A. Belinski⁷

¹ European Space Agency (ESA), European Space Astronomy Centre (ESAC), Camino Bajo del Castillo s/n, 28692 Villanueva de la Cañada, Madrid, Spain
e-mail: erwan.quintin@esa.int

² The Oskar Klein Centre, Department of Astronomy, Stockholm University, AlbaNova, SE-10691 Stockholm, Sweden

³ IRAP, Université de Toulouse, CNRS, CNES, UPS, Toulouse, France.

⁴ Institute of Physics of the Czech Academy of Sciences, Na Slovance 1999/2, 182 00 Prague 8, Czech Republic

- All ZTF data, 2019-2025
- (mostly) the same selection and analysis, all rising segments
- visual vetting of ~2k candidates
- 89 final candidates
- 19 new TDE-like events
 - 9 in passive galaxies
 - 8 in active galaxies
 - 2 unclear activity
 - 4 interesting SNe

Name	RA	Dec	Redshift	$M_{\text{abs,g}}^{\text{peak}}$ [mag]	IR echo	Comments	Still active
Candidates TDE							
AT2020ukj / ZTF20accxwrk	07:31:34.20	+57:16:29.04	0.089 ± 0.016 (P)	-19.0 ± 0.2	No	Very slow flare in passive galaxy	Yes
AT2023adr / ZTF22abzajwl	14:36:19.83	+32:23:16.46	0.131 (S)	-20.7±0.1/-19.3±0.1	Hints	Repeated flares in passive galaxy	Maybe
AT2023npi / ZTF18acfhomp	00:12:15.73	+22:19:18.34	0.0256 (S)	-16.8 ± 0.1	Yes	Very faint flare	No
AT2020pno / ZTF20abjwqqq	16:46:37.04	+55:36:26.81	0.279 (S)	-21.5 ± 0.1	Yes	Hints of late-time plateau	No
AT2020aexc / ZTF21aabgicz	12:07:13.45	+44:10:15.60	0.43 ± 0.03 (P)	-22.6 ± 0.3	Hints		No
ZTF20aatpzog	11:18:54.34	+21:49:42.44	0.38 ± 0.06 (P)	-21.8 ± 0.5	Yes		No
AT2020afap / ZTF18aasvknh	11:36:33.82	+61:43:39.00	0.099 (S)	-18.5 ± 0.1	Yes		No
AT2023jag / ZTF23aajsmul	16:09:12.09	+46:33:42.4	0.13 ± 0.05 (P)	-19.2 ± 0.1	No		No
AT2021ovg / ZTF21aazenvp	17:48:05.01	+40:14:17.42	0.24 ± 0.06 (P)	-20.4 ± 0.1	No		No
Candidates ANT							
ZTF23abjvojoy	02:34:39.04	+01:07:40.14	0.27 (S)	-21.2 ± 0.1	Yes	Repeated flares in active galaxy	Unclear
AT2022yhf / ZTF19aayijkh	21:46:06.85	-11:58:01.02	0.56 ± 0.03 (P)	-24.2 ± 0.2	Yes	ENT candidate	Yes
AT2024nxp / ZTF24aamfius	17:31:27.23	+57:36:58.09	1.7 ± 0.8 (P)	-25.5±1.5	No	ENT candidate – Rebrightening?	Yes
AT2023rav / ZTF23aaxaehw	23:51:14.69	+25:41:50.65	0.504 (S)	-24.2 ± 0.05	Yes	ENT candidate	Below quiescence
AT2020actc / ZTF20acxtaau	10:03:16.37	+21:05:45.85	0.145 (S)	-20.2 ± 0.1	Yes		No
AT2021wxd / ZTF21abvydim	15:58:19.21	+07:28:24.59	0.231 (S)	-21.0 ± 0.3	No		No
AT2024hhj / ZTF24aaimfrw	08:48:37.12	+33:50:15.01	0.217 (S)	-21.5 ± 0.5	No		No
AT2024gzn / ZTF24aafvgzk	17:55:16.11	+38:58:41.44	0.23 ± 0.03 (P)	-20.5 ± 0.2	No	Likely AGN burst	Rebrightening?
Ambiguous							
AT2023zaj / ZTF23abowyjf	00:37:34.44	-13:33:51.5	0.4 ± 0.1 (P)	-22.5±0.6	Yes	ANT or TDE	Yes
AT2023szj / ZTF23aajnfna	14:46:28.16	+08:41:36.7	0.57 ± 0.16 (P)	-23±0.75	Yes	Likely AGN burst	Rebrightening?
Candidates SNe							
AT2021lnu / ZTF21aazrgtw	15:32:18.68	-00:00:00.74	0.15 ± 0.07 (P)	-20.2±1.2	No	SLSN candidate	No
AT2020mvg / ZTF20aazyvre	12:05:26.53	+28:54:34.36	0.31 ± 0.11 (P)	-22.4±0.9	Unclear	SLSN candidate	No
AT2019agc / ZTF19aafmytc	14:06:45.32	+13:55:04.7	0.15 ± 0.05 (P)	-19.7±0.7/-19.7±0.7	No	Multiple SNe	No
AT2024ljd / ZTF20aacdmi	21:13:39.44	+02:29:36.59	0.046 (S)	-19 ± 0.05	No	Confirmed SN Ia	No

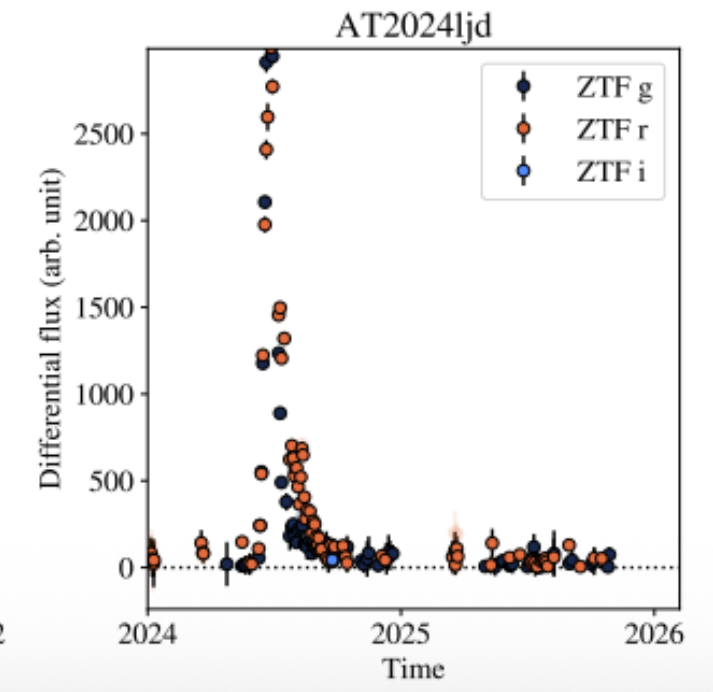
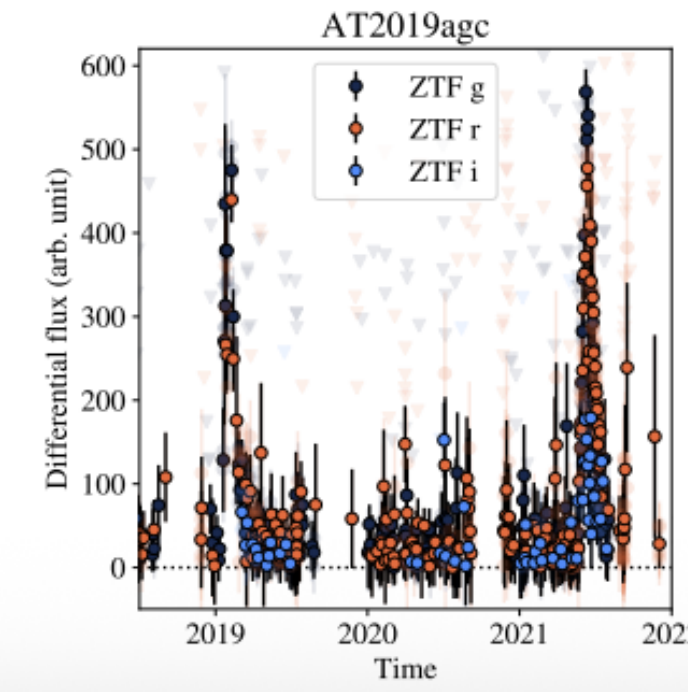
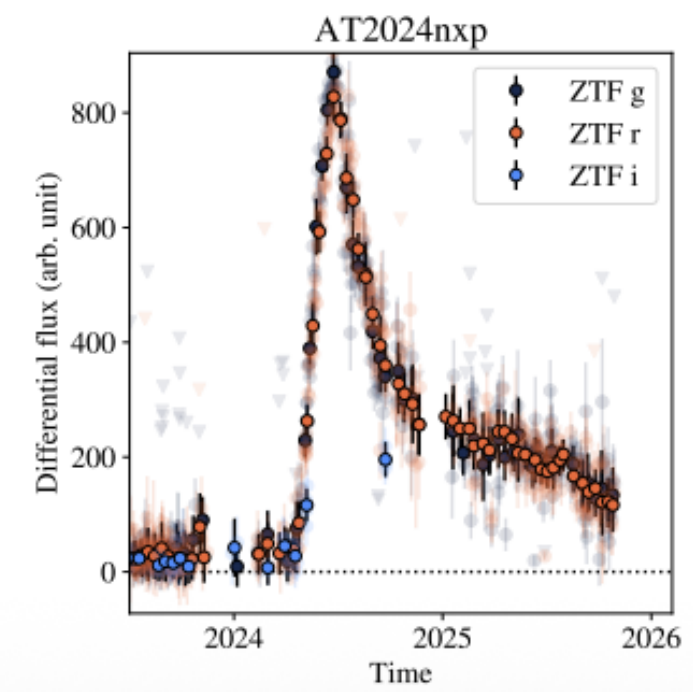
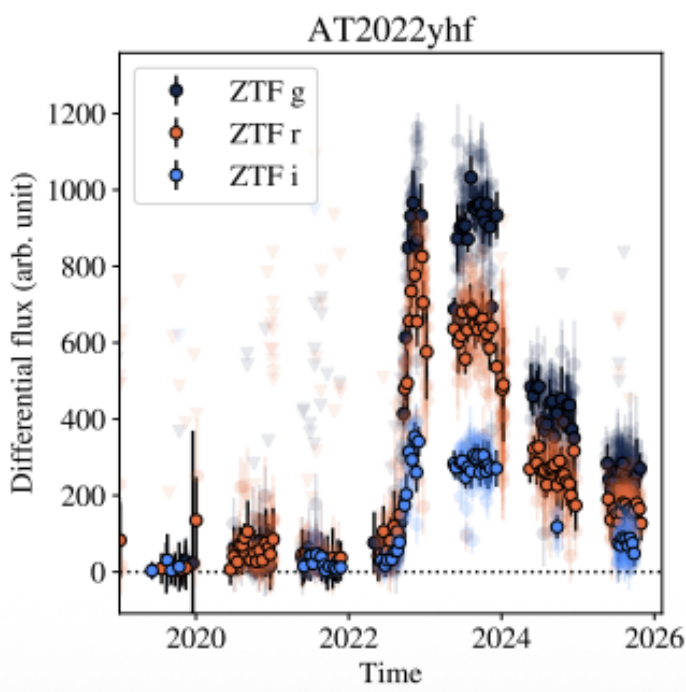
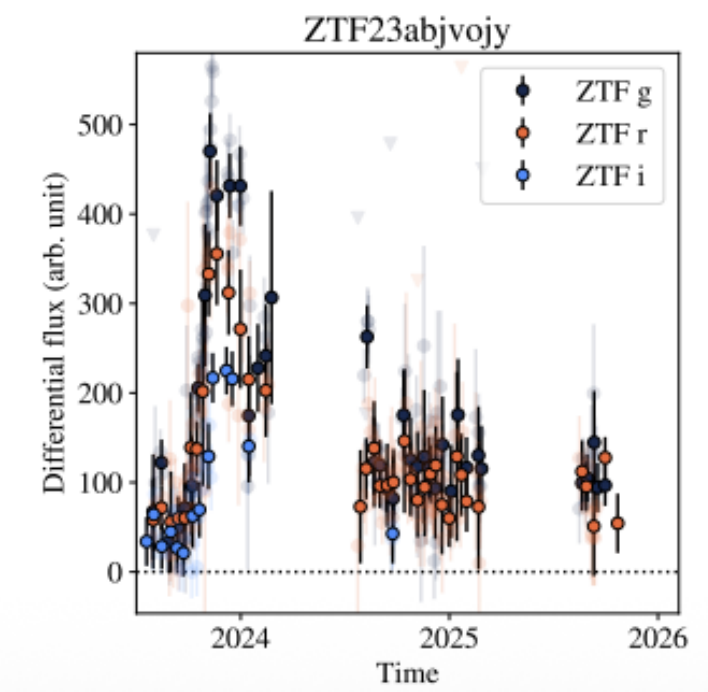
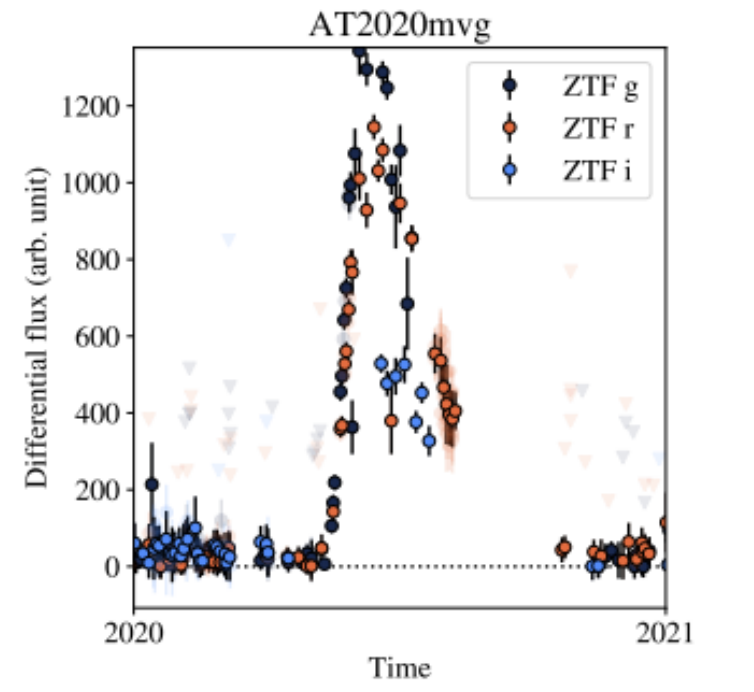
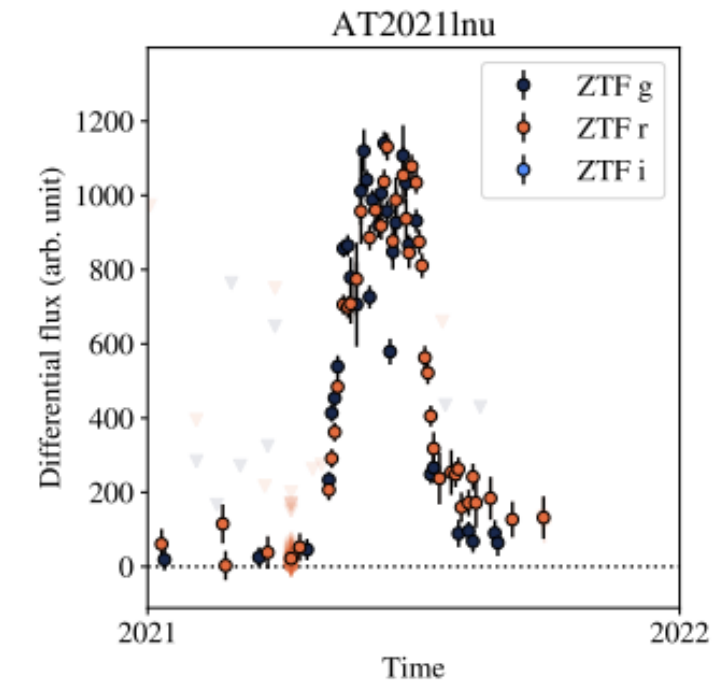
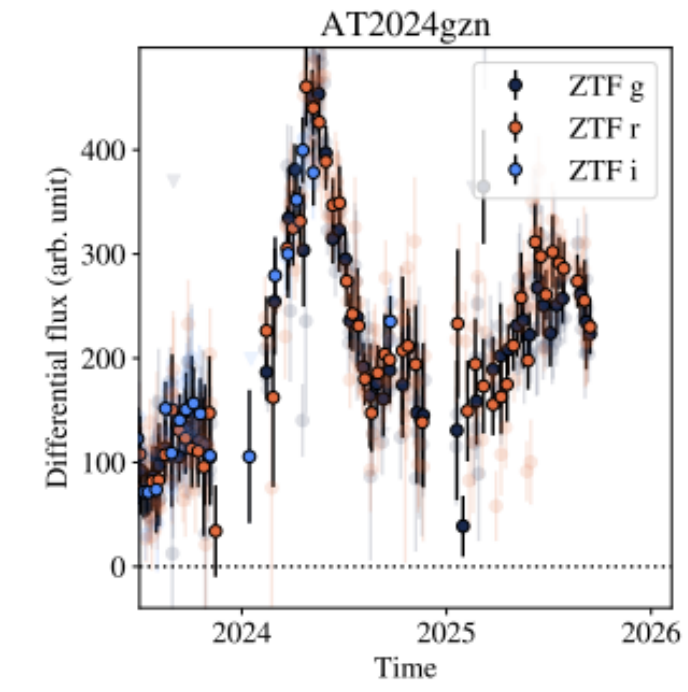
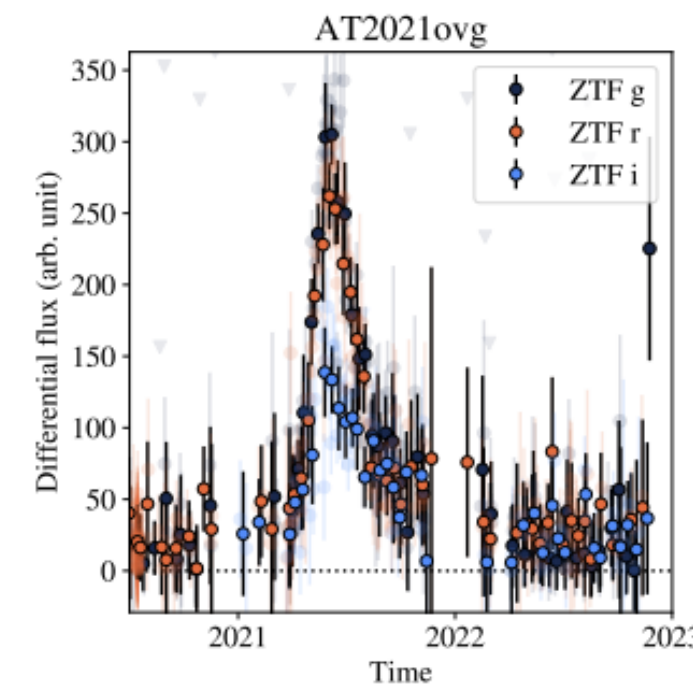
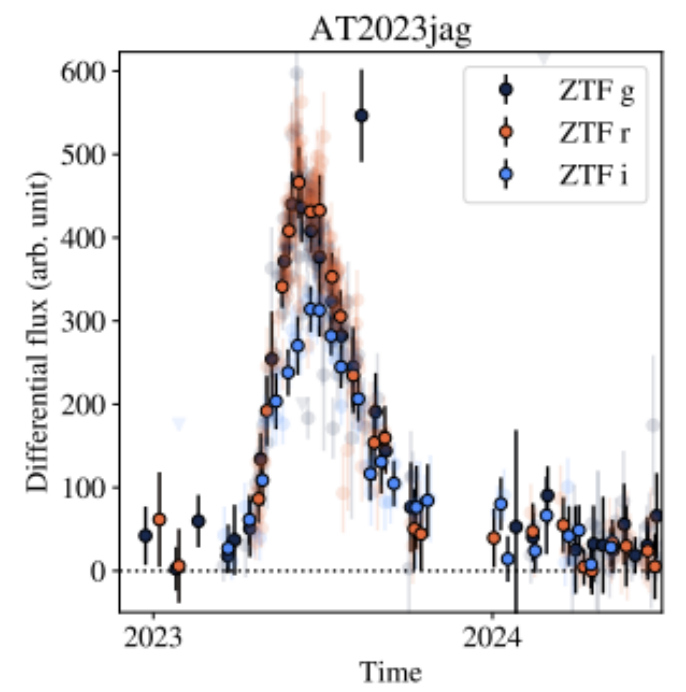
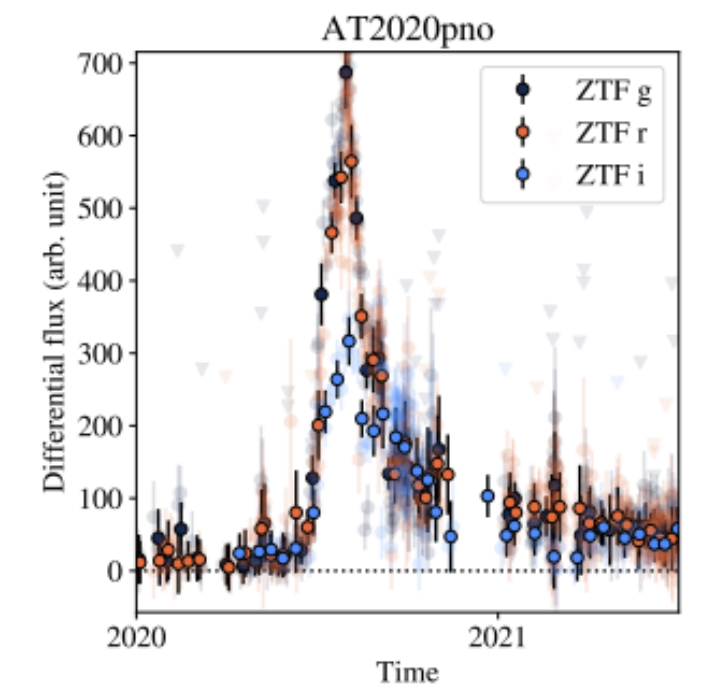
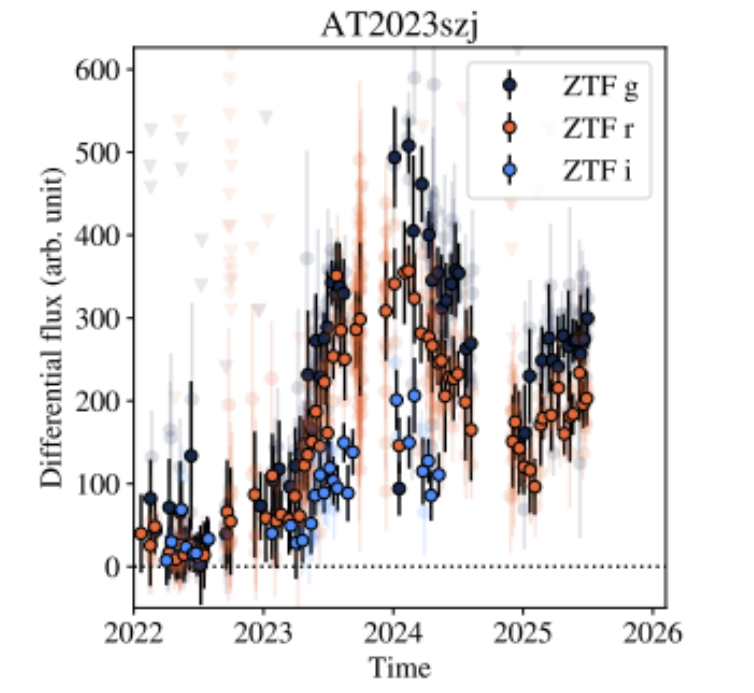
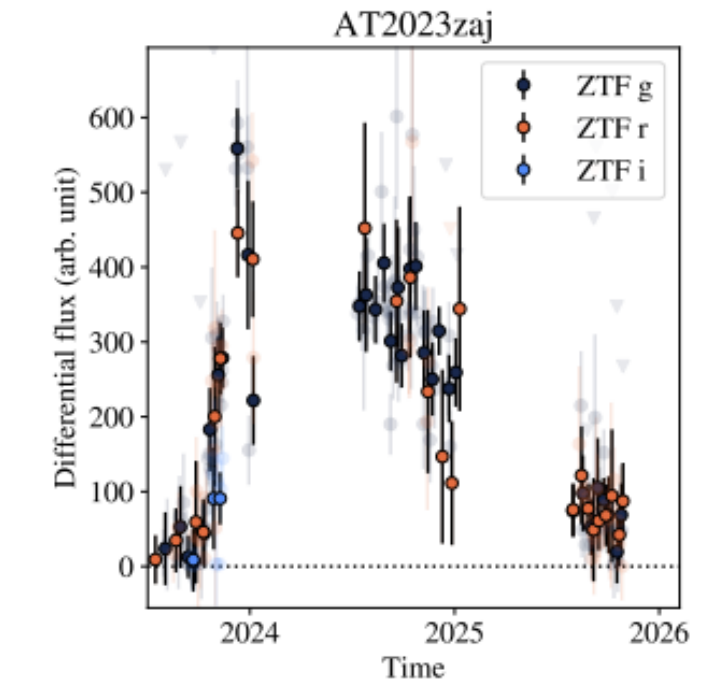
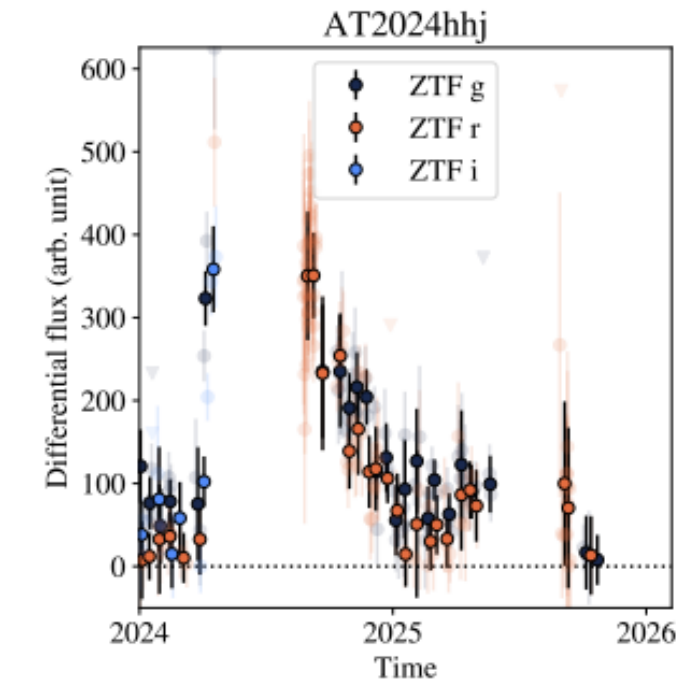
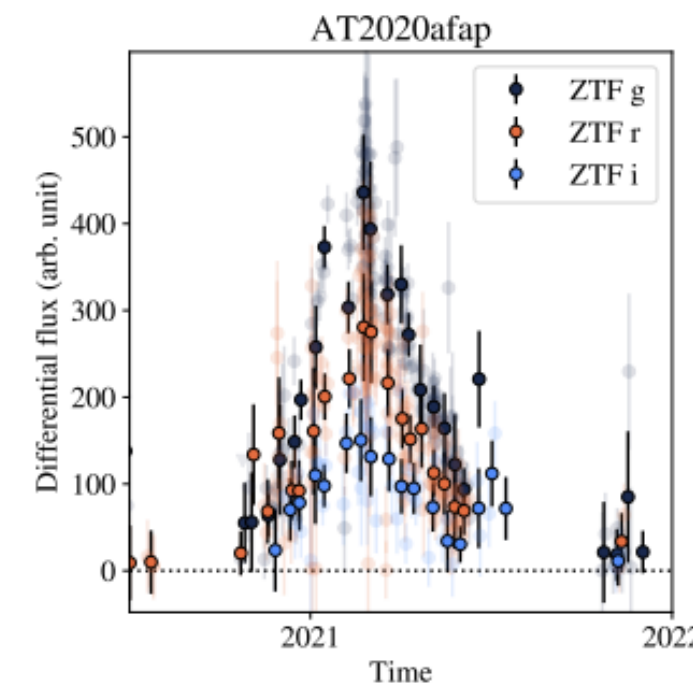
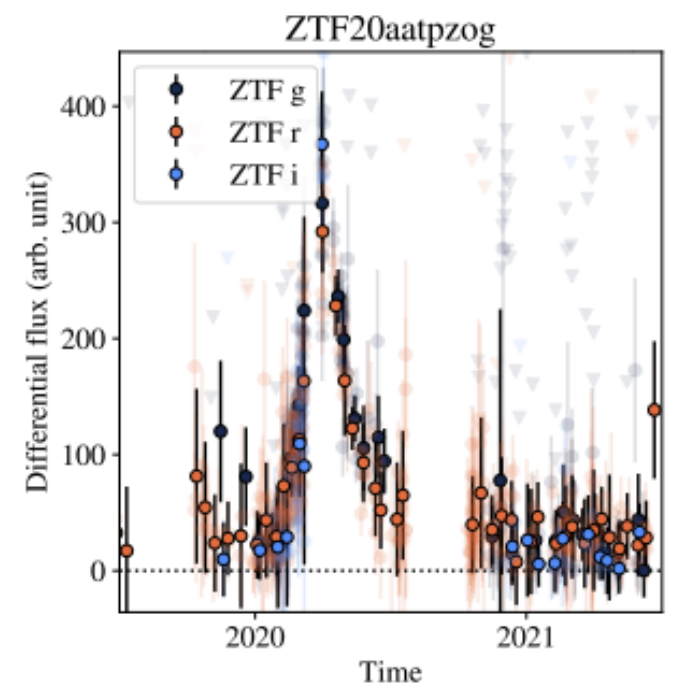
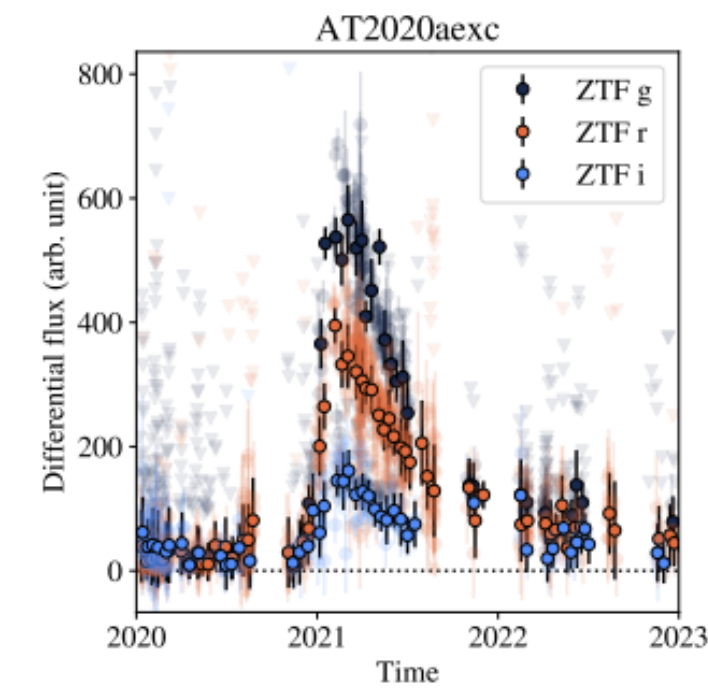
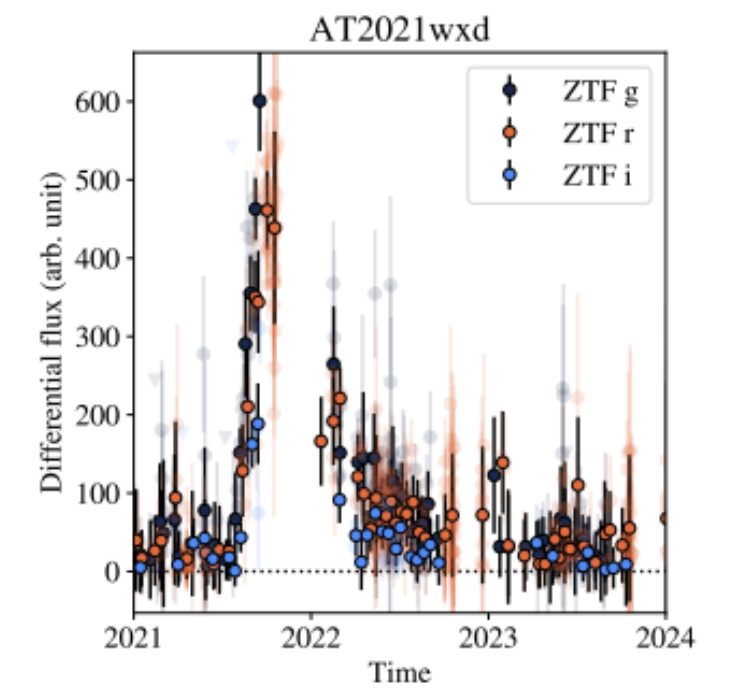
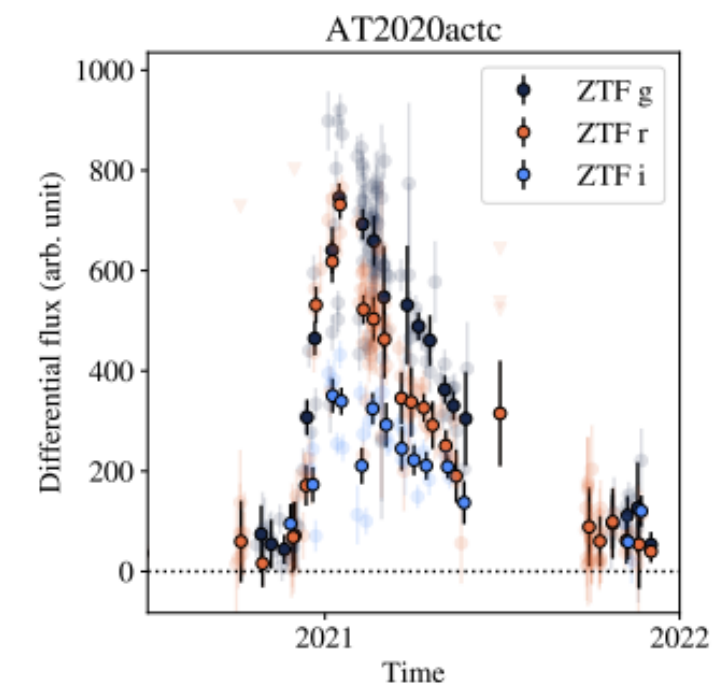
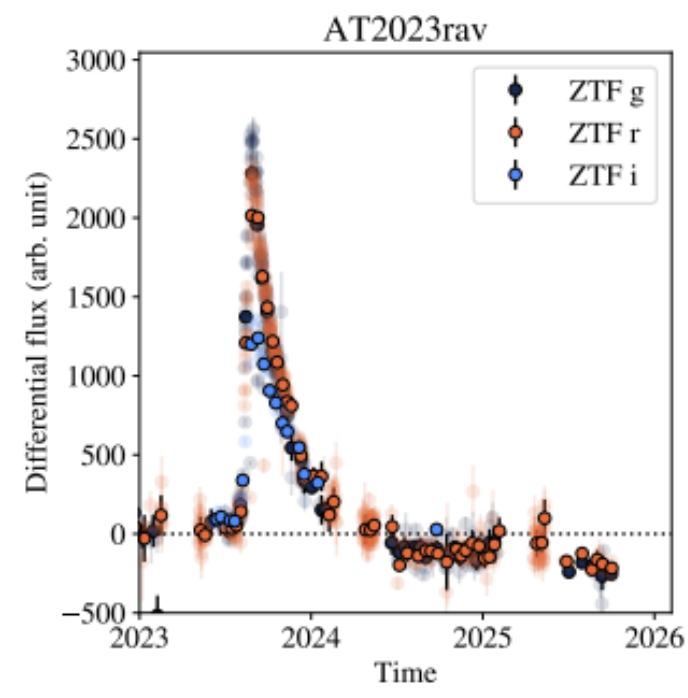
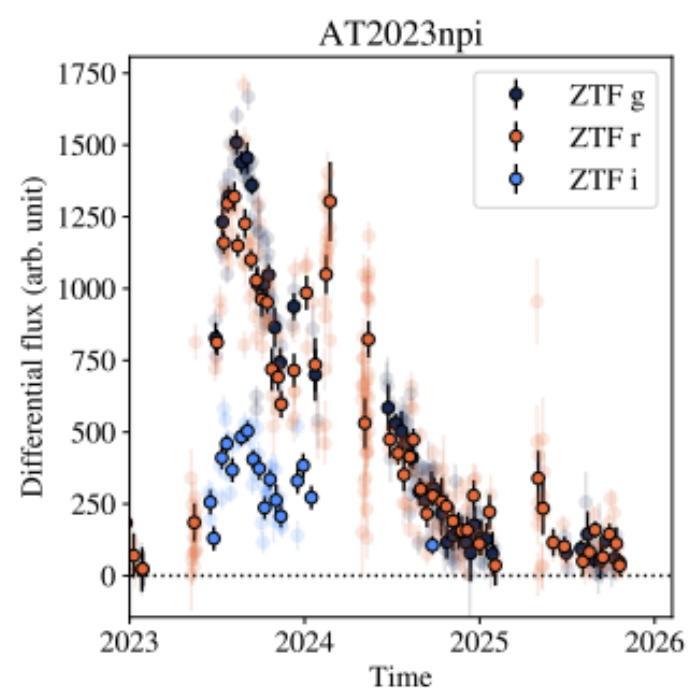
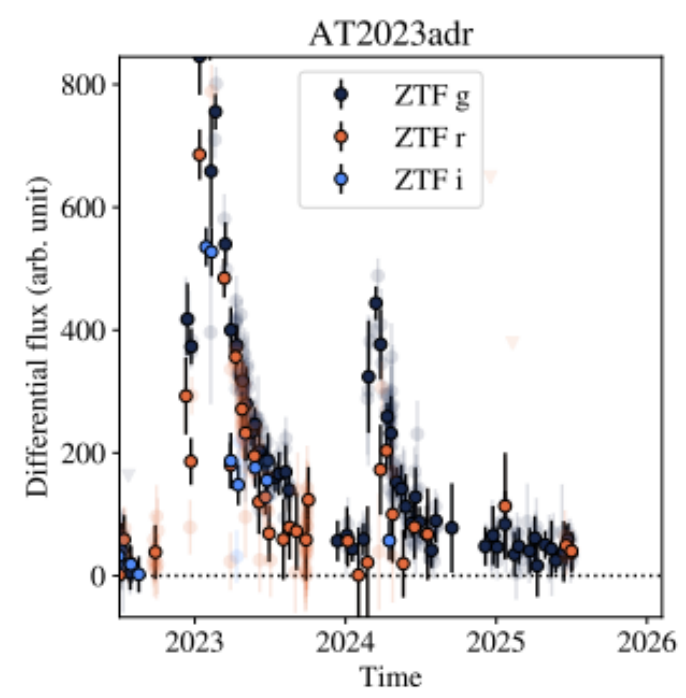
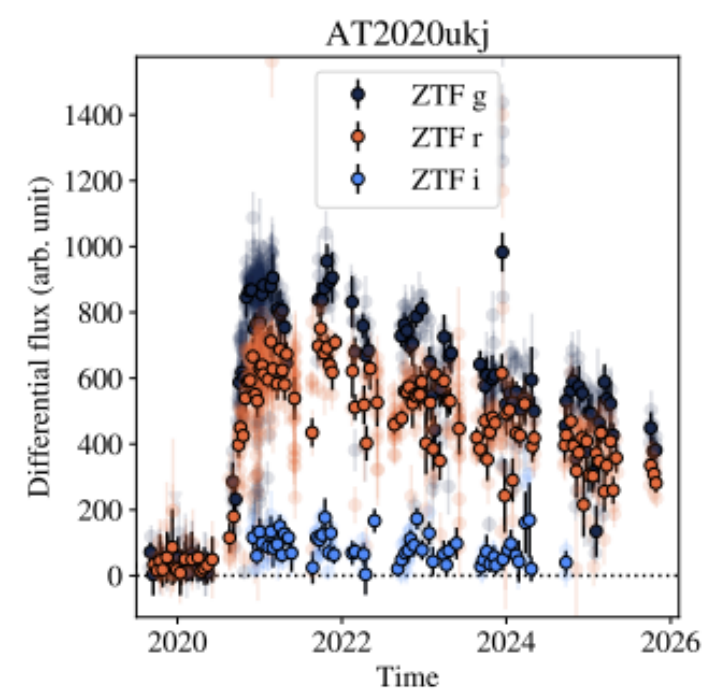

From ZTF to Rubin



Palomar 48-inch Samuel Oschin Telescope



VERA C. RUBIN
OBSERVATORY

8.4-m Simonyi Survey Telescope

ZTF (2018 - 2027?..)

- Sky coverage once per 1-2 nights
 - *g* and *r* filters (*i* very rarely)
 - northern sky mostly
 - limit ~20.5 mag
- Public alerts for transients
 - differential photometry
 - 30-day history

Rubin / LSST (2026 - 2036???)

- *ugrizy* filters, southern sky
- limit ~24.5 mag ???
- forced photometry 30 days to a year



Rainbow fitting

Russeil et al. (2024)

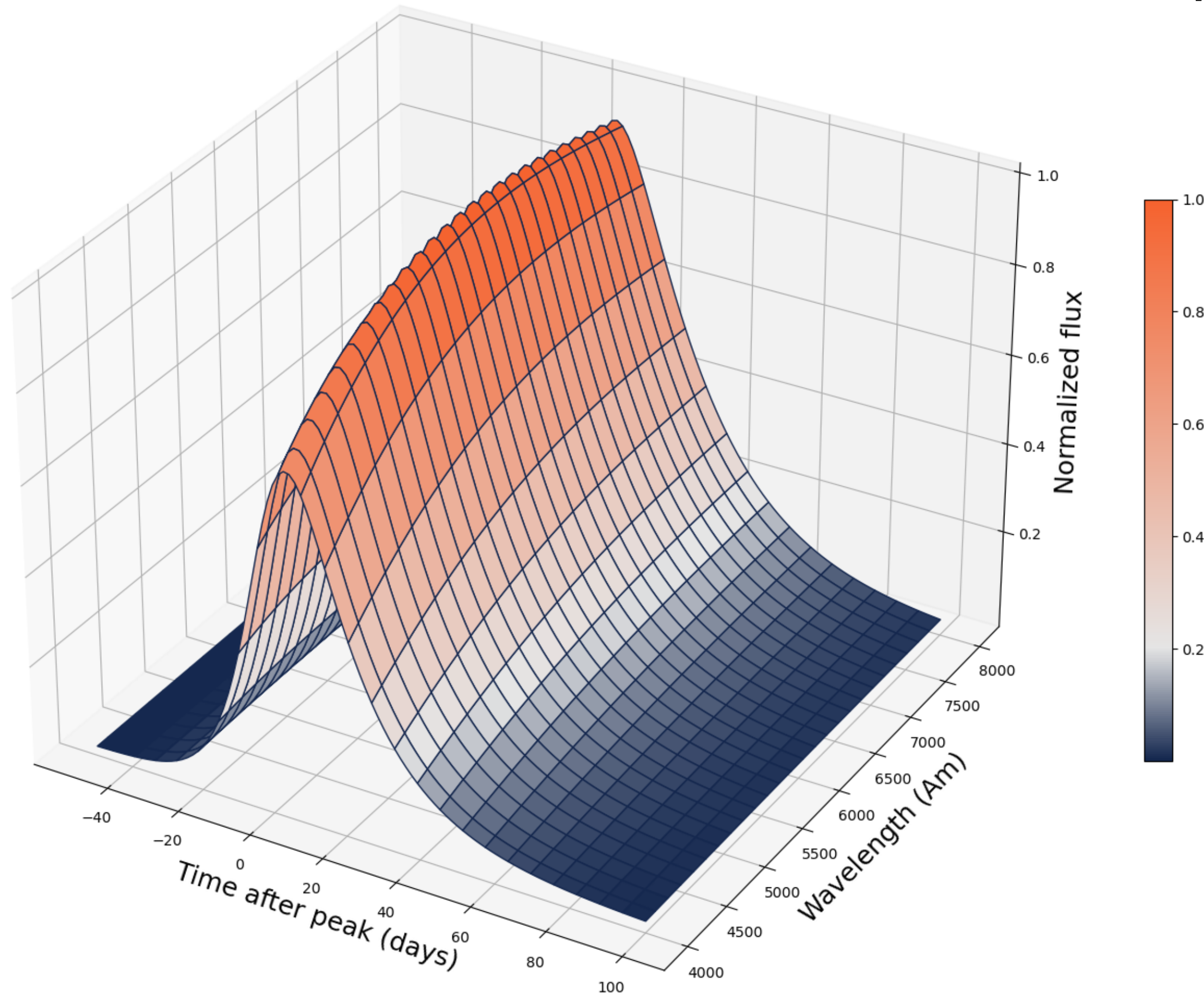

Simple analytic decomposition of observed multi-color light curves into temperature and bolometric luminosity terms, assuming blackbody spectrum

$$F_{\nu}(t, \nu) = \frac{\pi}{\sigma_{SB}} \times \frac{B_{\nu}(T, \nu)}{T(t)^4} \times F_{bol}(t)$$

$$T(t) = T_{min} + \frac{T_{max} - T_{min}}{1 + e^{-\frac{t-t_0}{\tau}}}$$

sigmoid

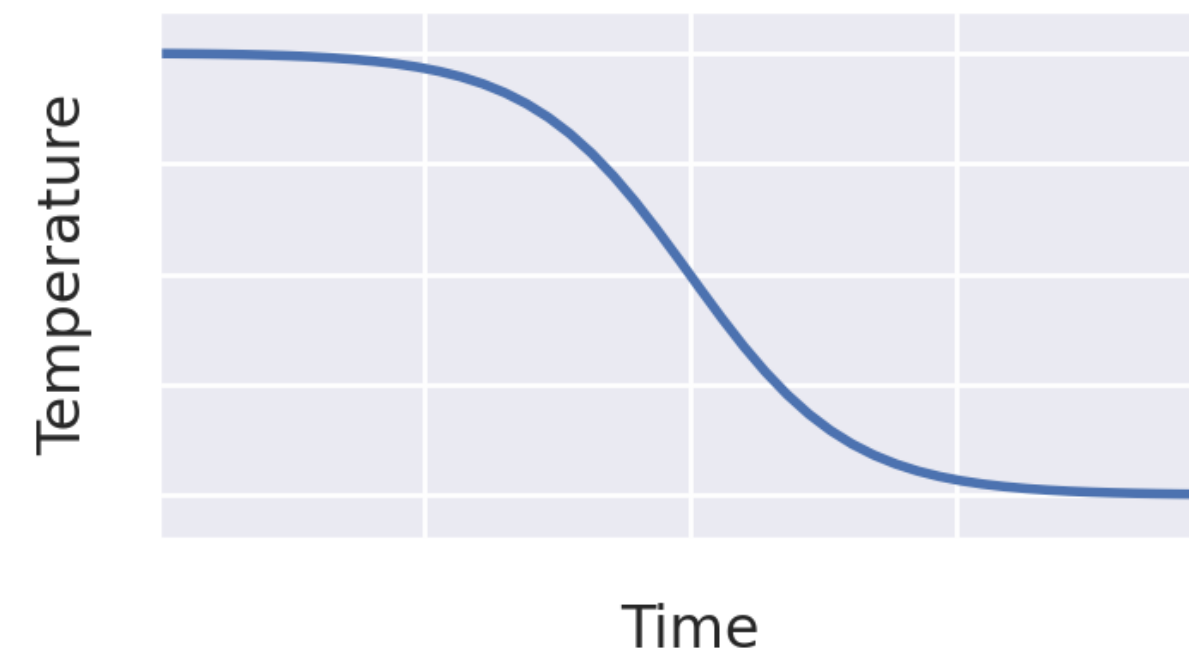

$$F_{bol}(t) = \frac{A}{e^{-\frac{t-t_0}{\tau_{rise}}} + e^{\frac{t-t_0}{\tau_{fall}}}}$$

Bazin

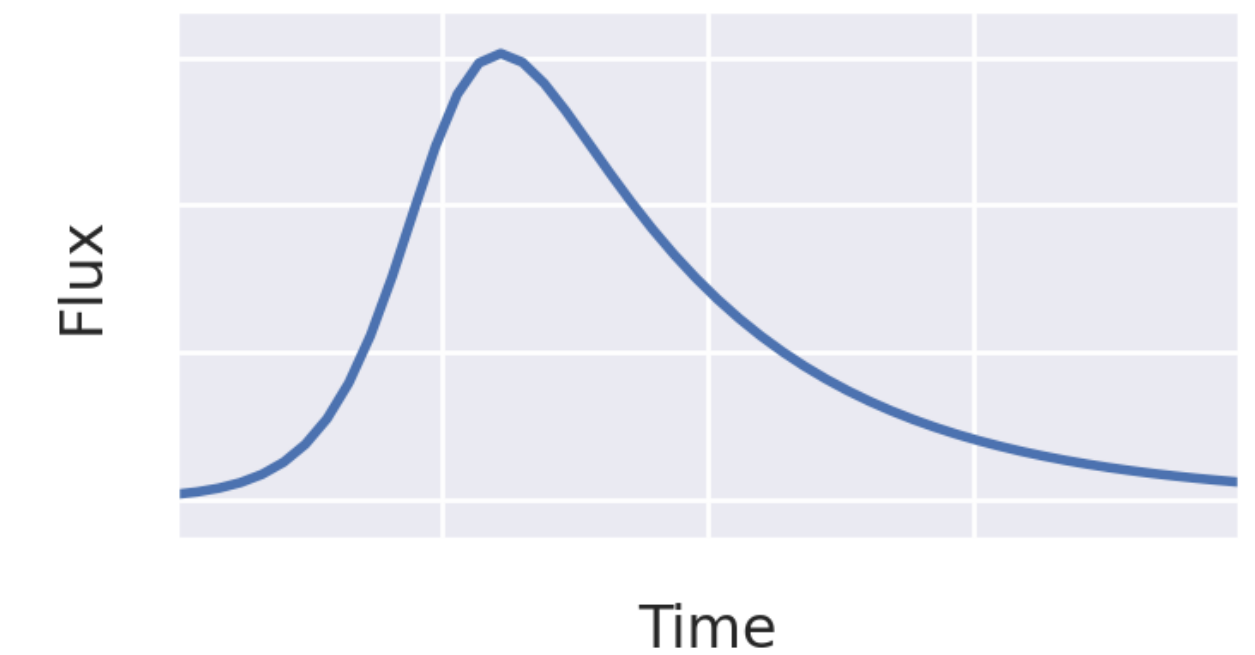

Supernova-like light curves - 6 to 8 parameters

Rainbow fitting

Russeil et al. (2024)

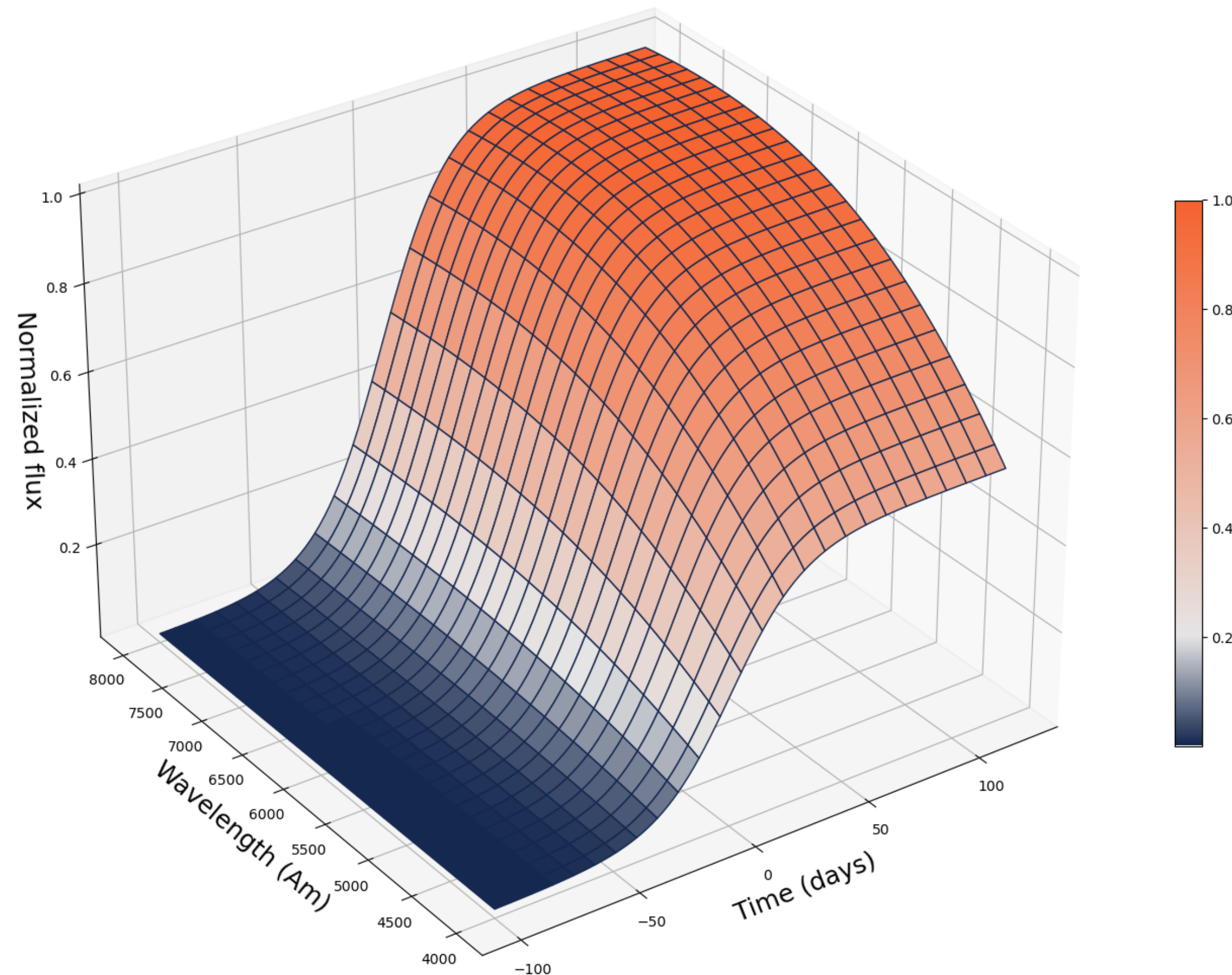

Simple analytic decomposition of observed multi-color light curves into temperature and bolometric luminosity terms, assuming blackbody spectrum

$$F_{\nu}(t, \nu) = \frac{\pi}{\sigma_{SB}} \times \frac{B_{\nu}(T, \nu)}{T(t)^4} \times F_{bol}(t)$$

$$T(t) = \text{const}$$

constant

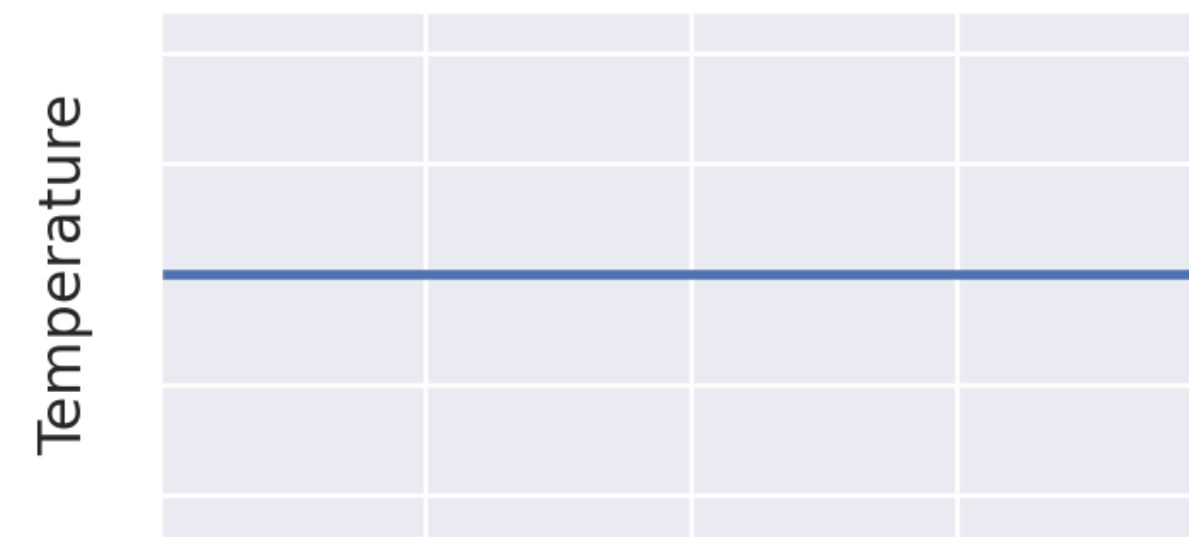

$$F_{bol}(t) = \frac{A}{1 + e^{-\frac{t-t_0}{\tau}}}$$

sigmoid

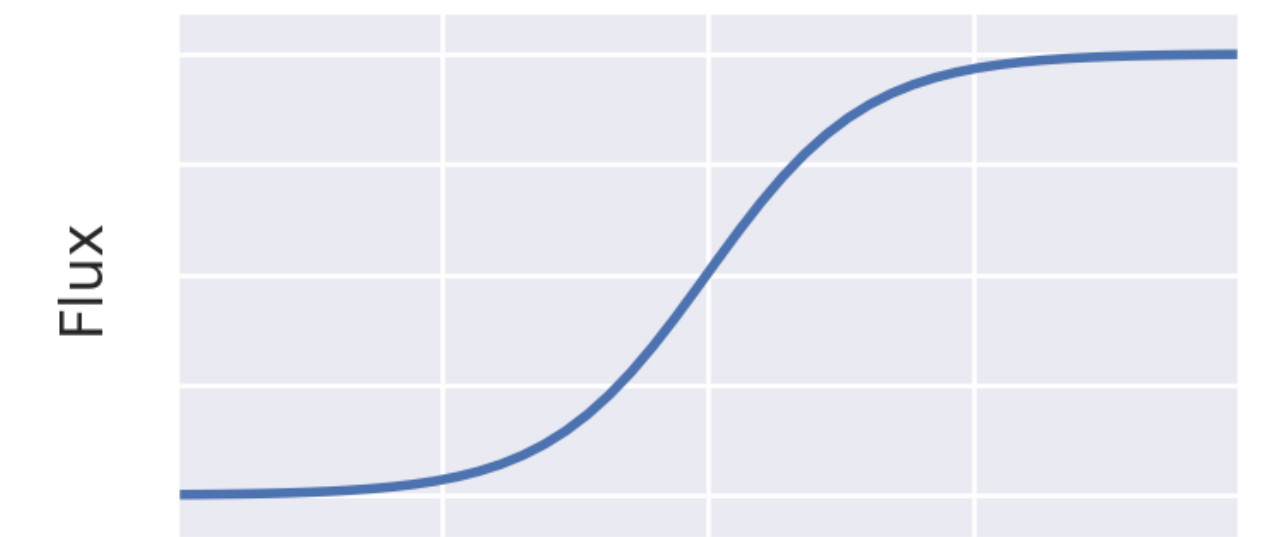

Early TDE-like light curves - 4 parameters

Rainbow for Rubin - blanketing

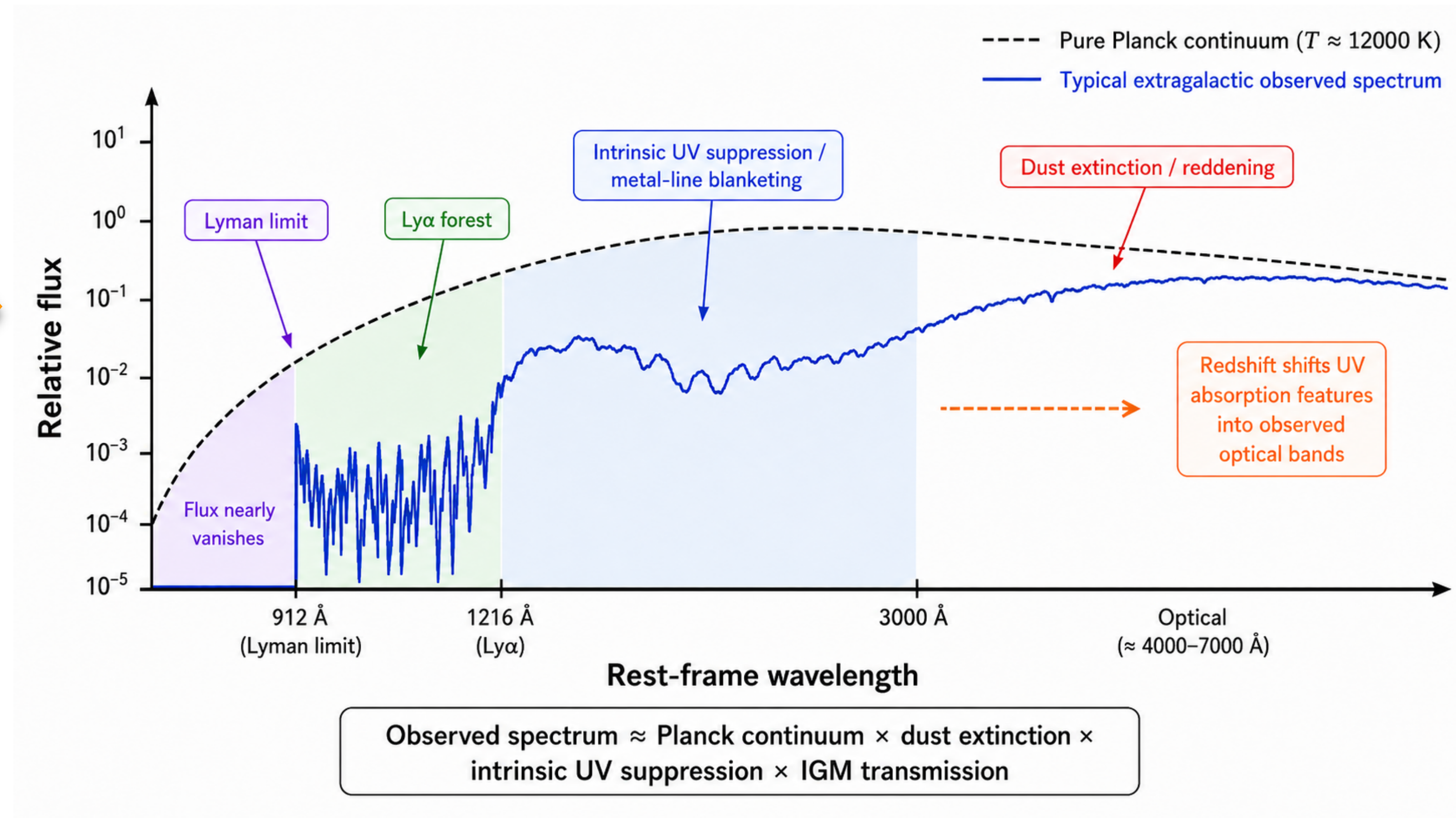
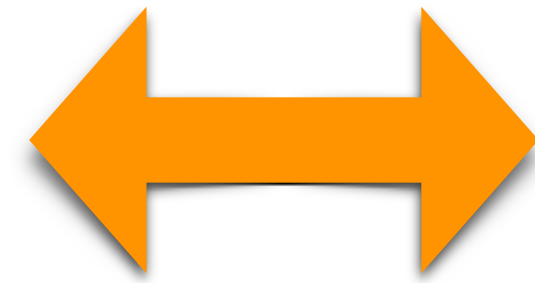
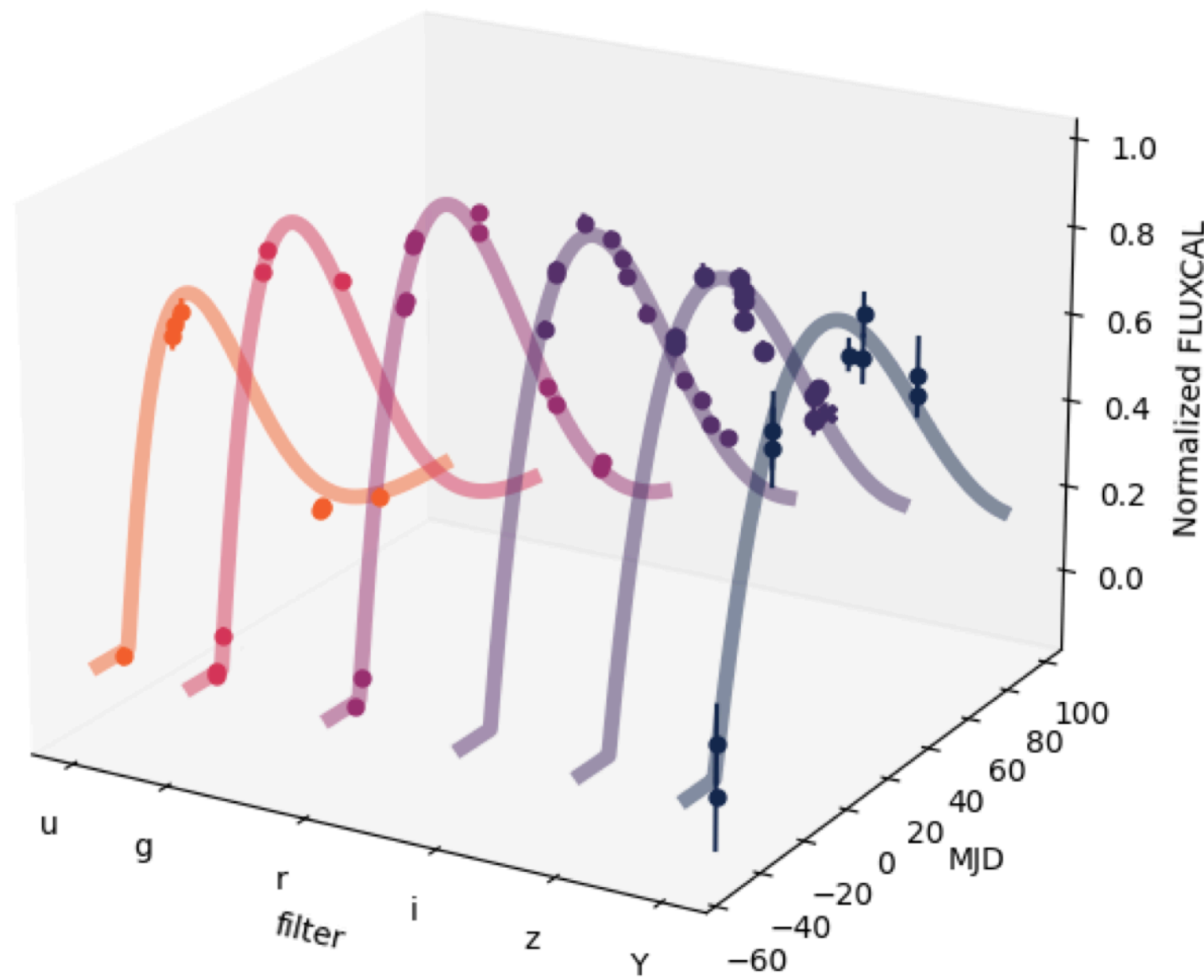

Russeil et al. 2024

(originally) purely Planck spectrum

blanketed

$$F_\lambda = B_\nu(\lambda, T) e^{-\tau}, \quad \tau = I e^{-\lambda/\lambda_s}, \quad \lambda_s \propto \lambda_{\text{scale}}/T_{\text{ref}}$$

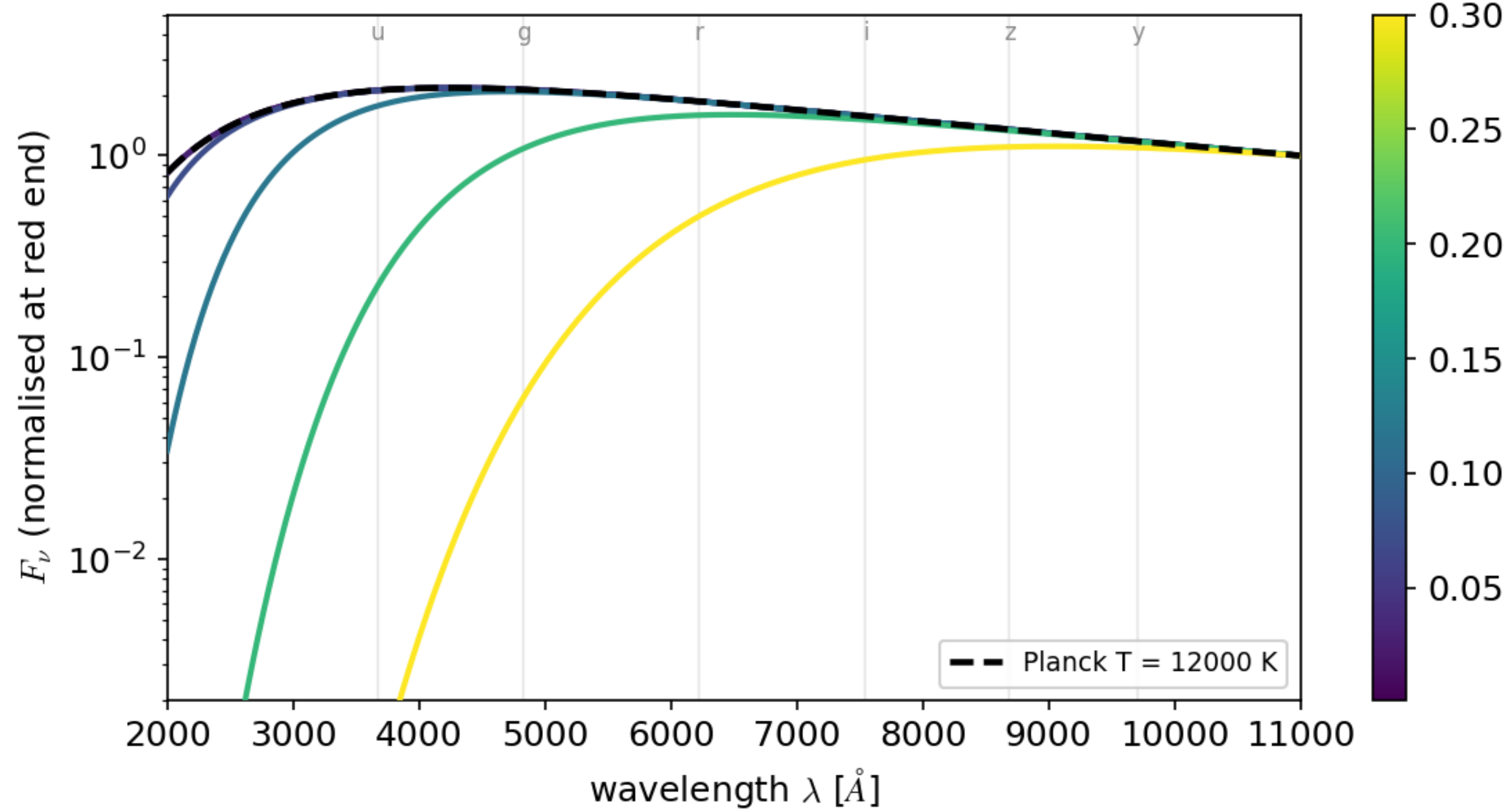

genwien

$$B_\nu \propto \nu^3 e^{-x^k}, \quad x = h\nu/k_B T$$

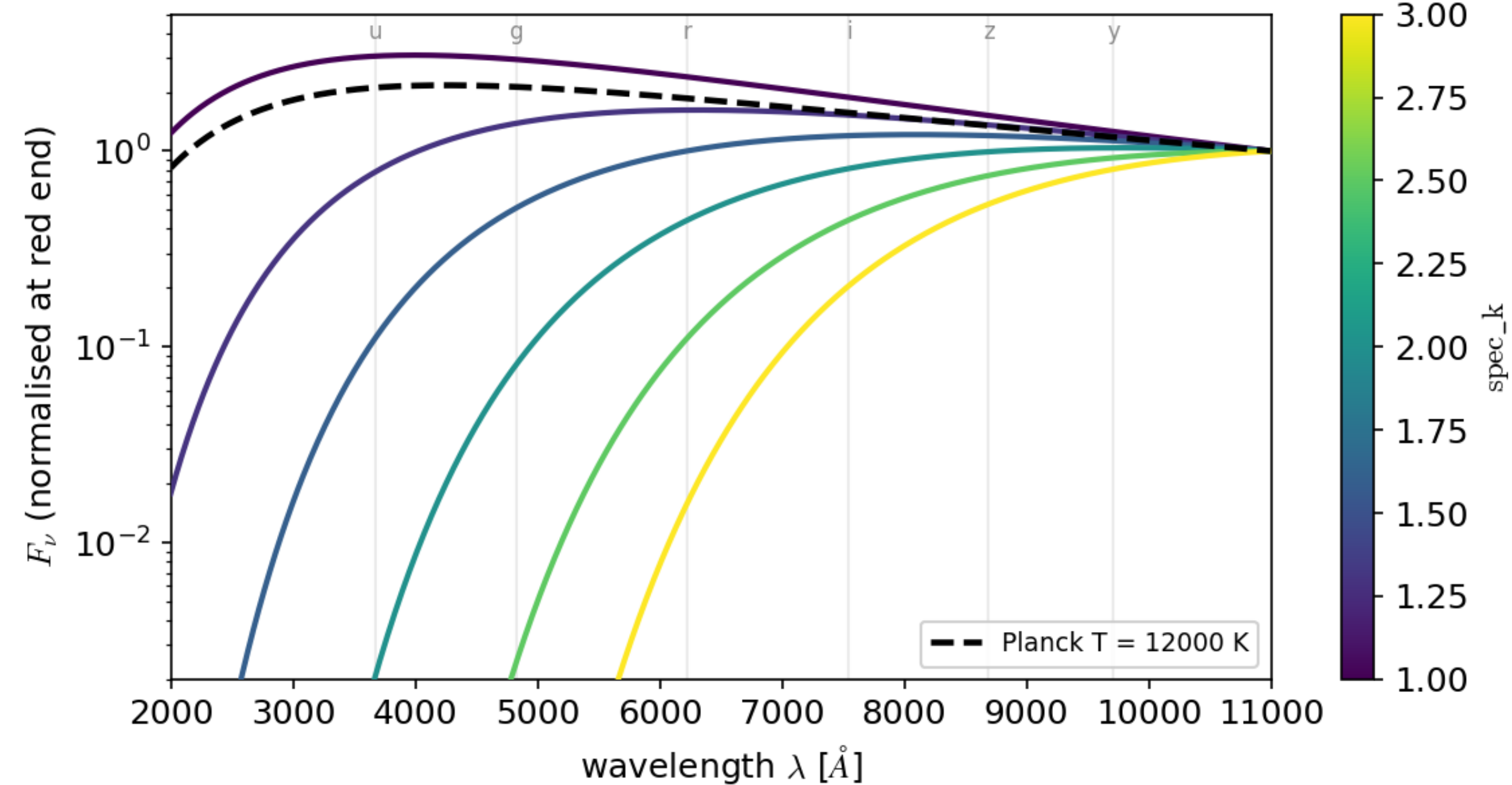

modified_bb

$$F_\lambda = B_\nu(\lambda, T) (\lambda/\lambda_{\text{ref}})^\beta$$

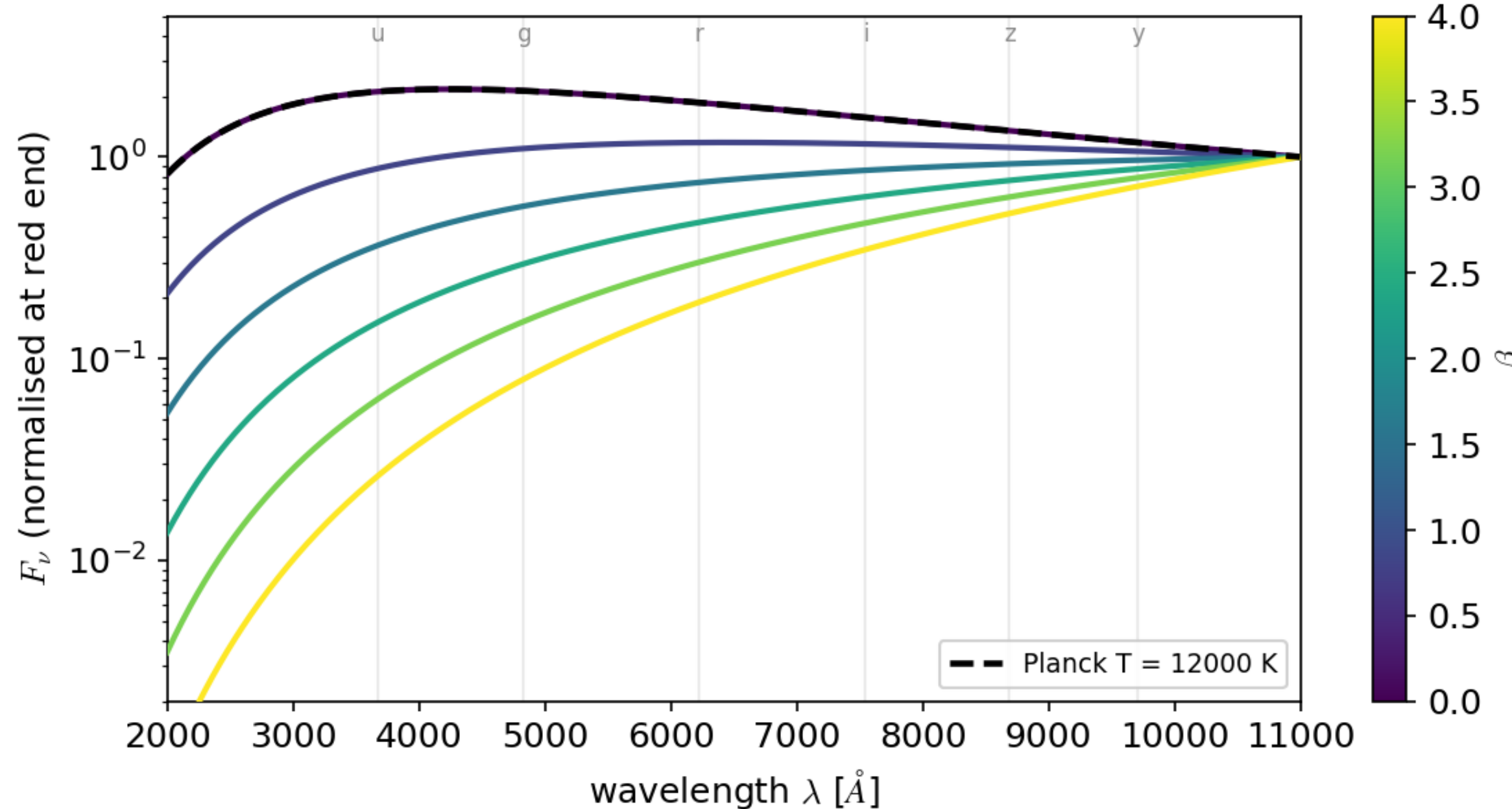

logparabola

$$F_\lambda = B_\nu(\lambda, T) e^{aL + bL^2}, \quad L = \ln(\lambda/\lambda_{\text{ref}})$$

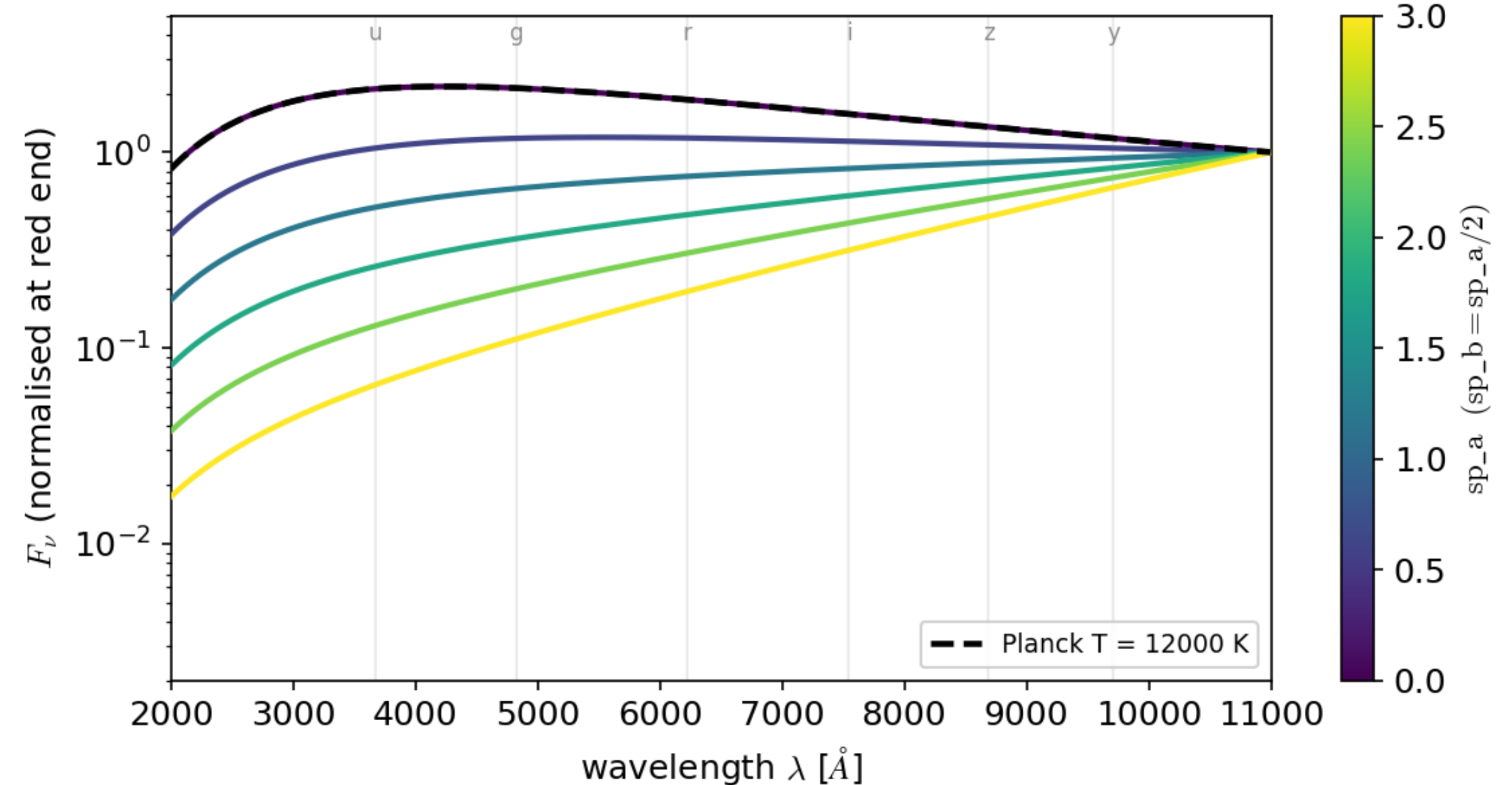

“Rubin TDE dataset”

- 2025 data challenge & Kaggle competition
- **Data-driven simulation:**
starts from 64 spectroscopically confirmed TDEs + 727 nuclear SNe + 1,407 AGN observed by ZTF (2017–2023)
- Each ZTF light curve → **GP fit** → propagated to LSST cadence (baseline v5.0), depth, and all six bands (u, g, r, i, z, y) via SNCosmo SED templates
- **~10,000** simulated LSST light curves released; 30/70 train/test split

MALLORN: many artificial LSST light curves based on observations of real nuclear transients

Dylan Magill ¹★, M. Nicholl ¹, V. Anilkumar ², S. van Velzen ², X. Sheng ¹, T. S. Mai ³,
H. V. Tran ³, N. P. Doan ³, T. Moore ^{1,4}, S. Srivastav ⁵, D. R. Young ¹, C. R. Angus ¹ and
J. Weston ¹

¹Astrophysics Research Centre, School of Mathematics and Physics, Queen's University Belfast, Belfast BT7 1NN, UK

²Leiden Observatory, Leiden University, Postbus 9513, NL-2300 RA Leiden, the Netherlands

³School of Electronics, Electrical Engineering and Computer Science, Queen's University Belfast, Belfast BT9 5BN, UK

⁴Space Telescope Science Institute, 3700 San Martin Dr, Baltimore, MD 21218, USA

⁵Astrophysics sub-Department, Department of Physics, University of Oxford, Keble Road, Oxford OX1 3RH, UK

Accepted 2026 March 3. Received 2026 January 21; in original form 2025 December 4



Rainbow for Rubin - supernovae

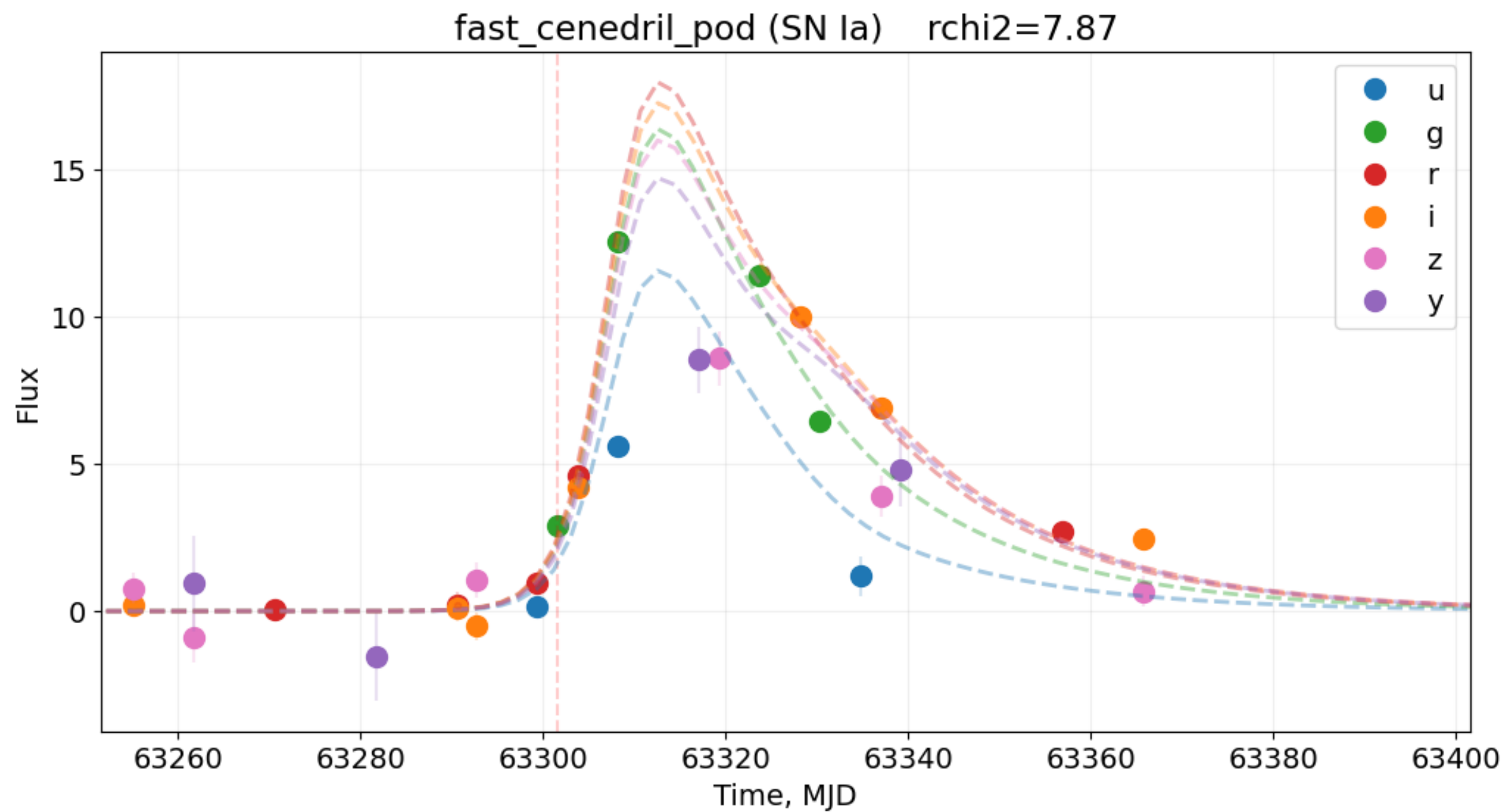

Planck spectrum

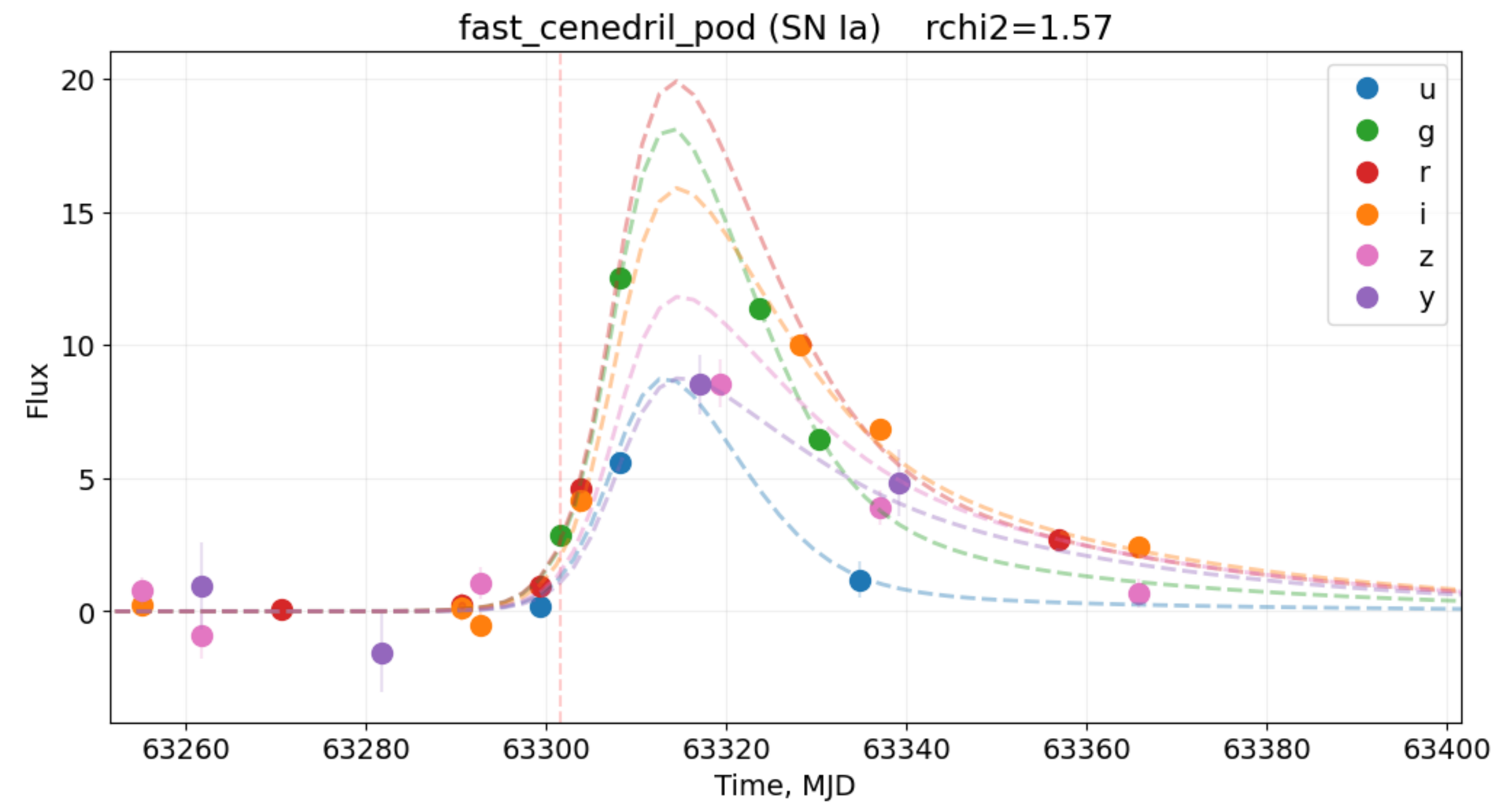

Modified Blackbody spectrum

beta = -4.3

$$F_{\lambda} = B_{\nu}(\lambda, T) (\lambda/\lambda_{\text{ref}})^{\beta}$$

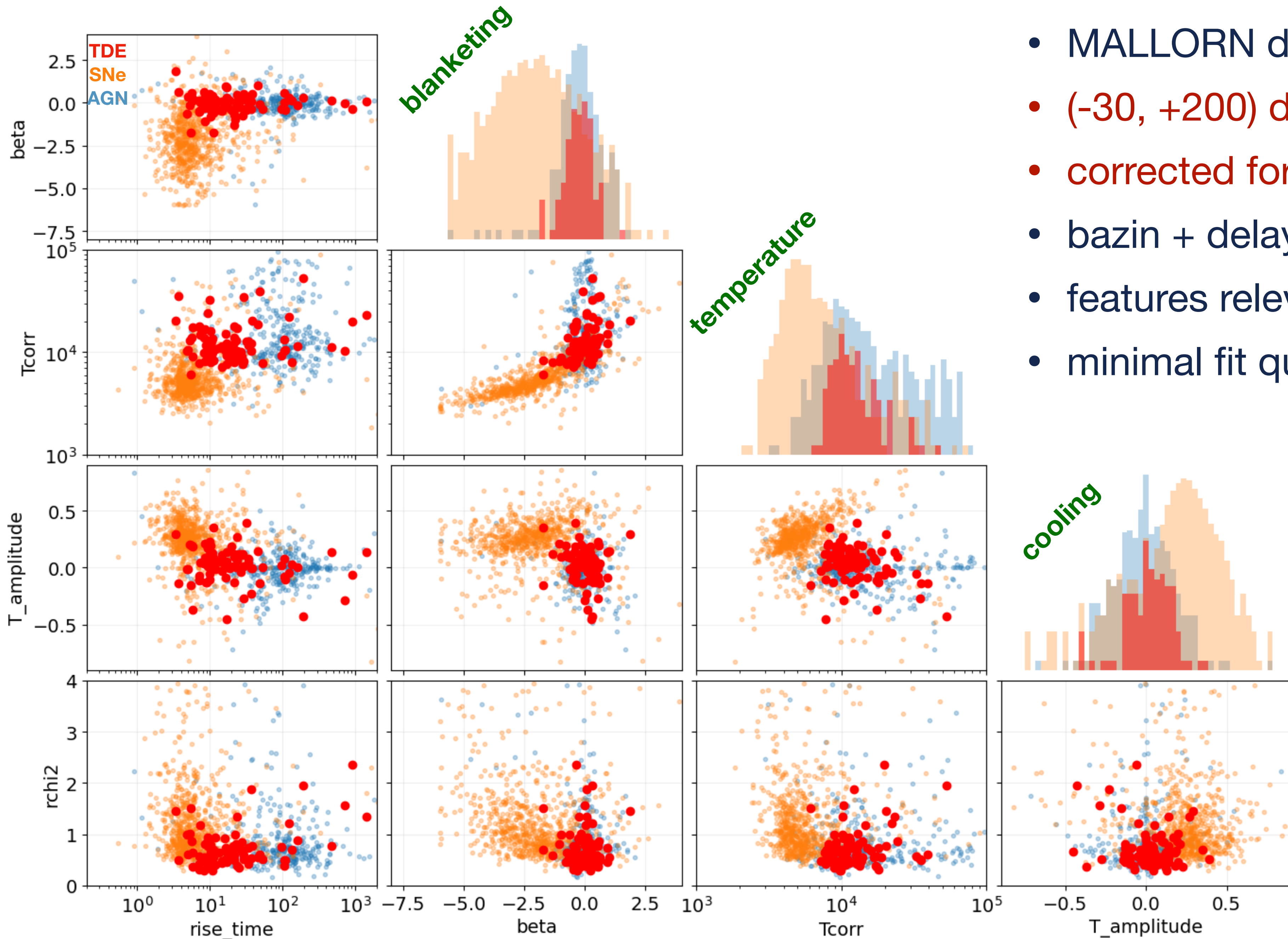

- MALLORN dataset, labelled test set
- (-30, +200) days around first trigger
- corrected for redshift (cheating!)
- bazin + delayed_sigmoid + modbb
- features relevant for early detection
- minimal fit quality checks

both blanketing
temperature and cooling
features are
promising discriminators!

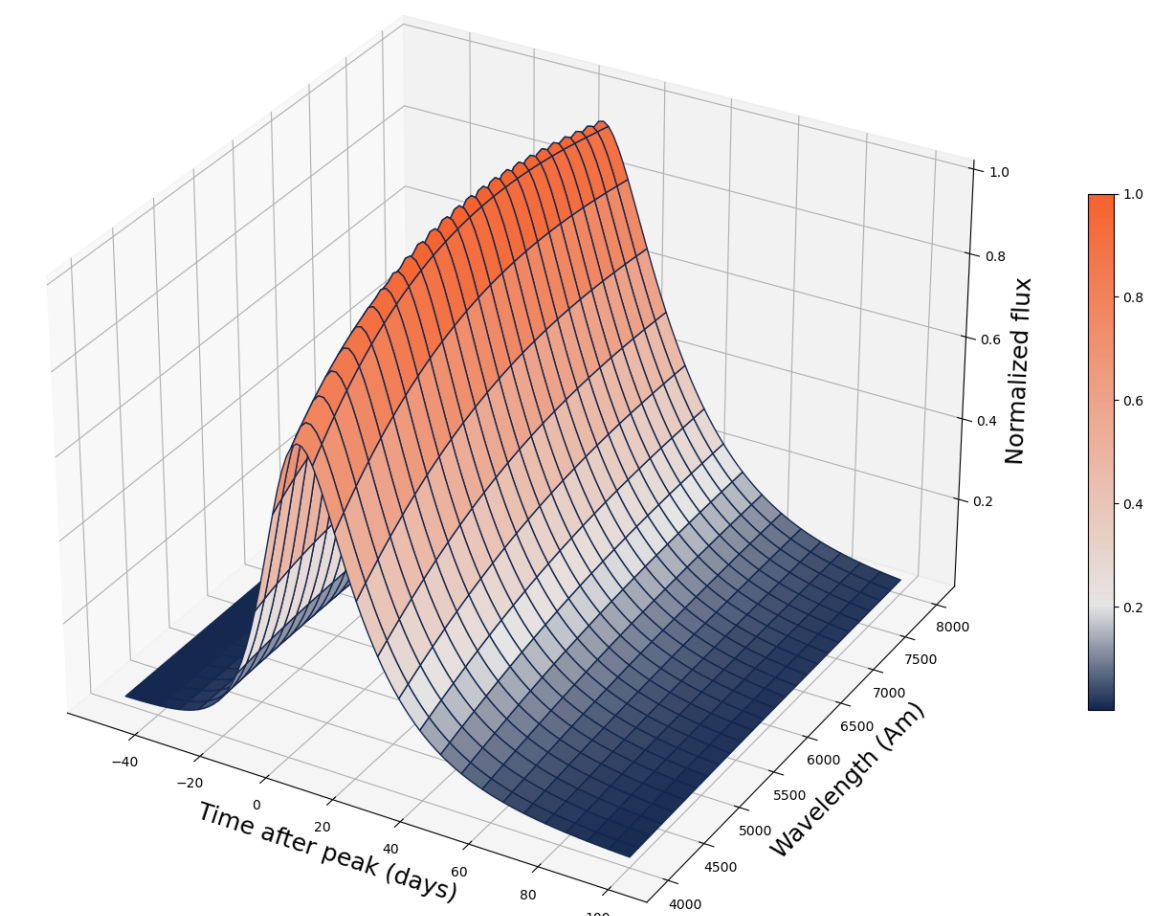

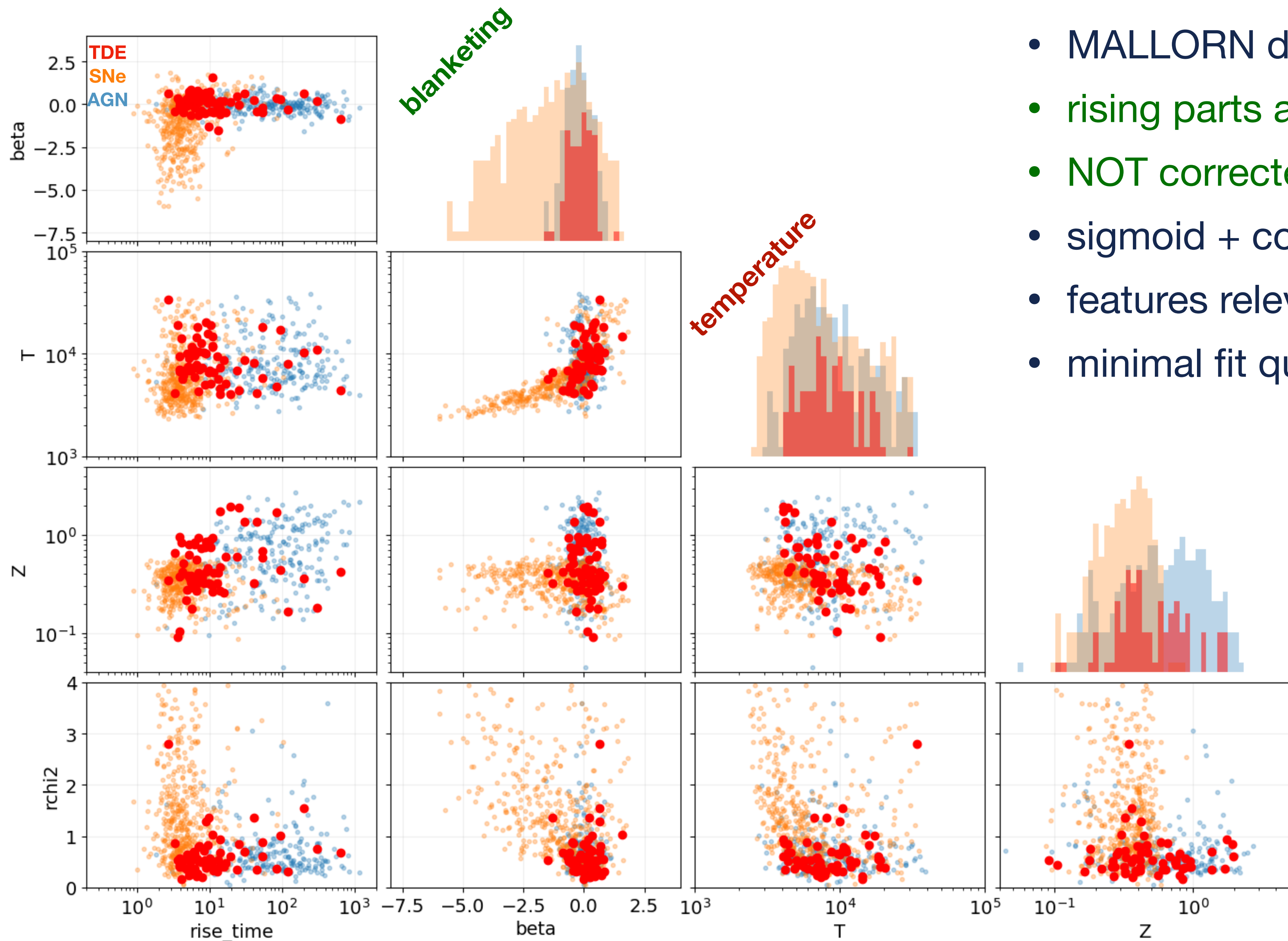

- MALLORN dataset, labelled test set
- rising parts after trigger + 30 days back
- NOT corrected for redshift!
- sigmoid + constant + modbb
- features relevant for early detection
- minimal fit quality checks

only blanketing
is discriminating?

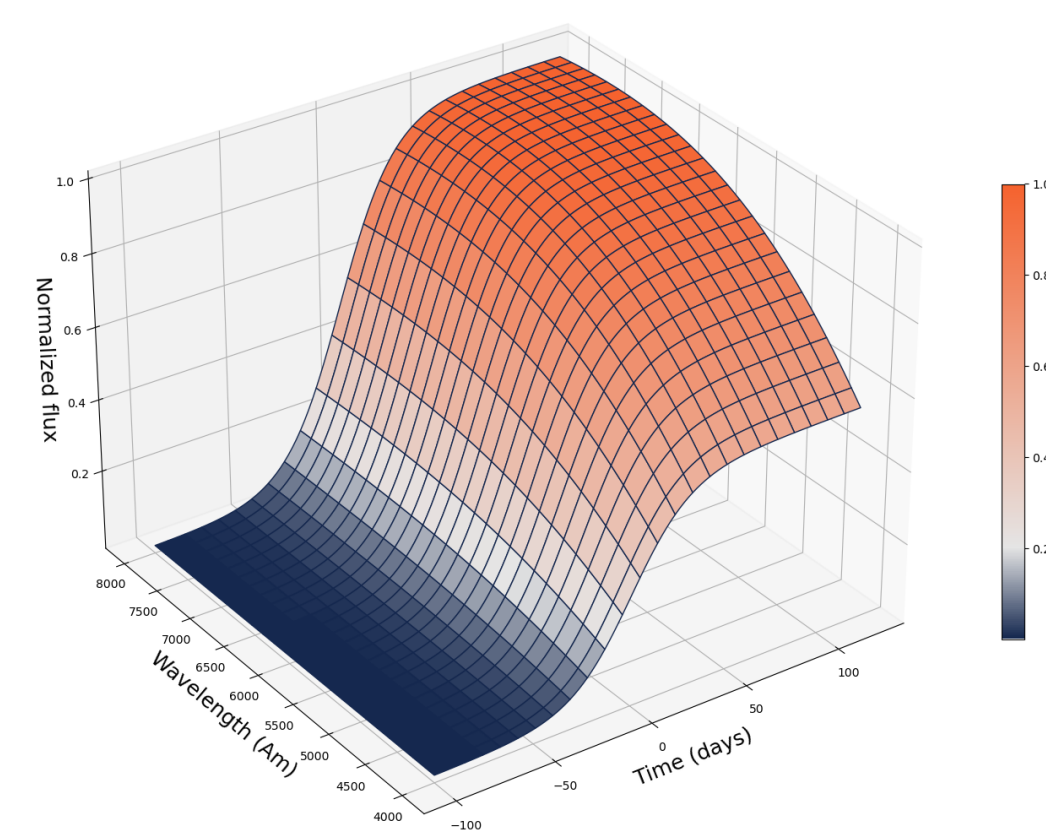

Adapting for Rubin / LSST

- Six bands instead of two
 - we need better SED models
 - being implemented in Rainbow now
 - ...gives strange results yet
- Rainbow fitting is still a good approach
 - 5 parameters for sigmoid / rising / blanketed
 - 9 parameters for bazin / full / blanketed
- The classes are still separable
 - blanketing instead of temperature?..
- Slower cadence, both in general and per-filter
 - different pre-filtering criteria?
 - different history / forced phot handling?

