

What is the 650 GeV resonance made of ?



IRN Terascale @ IJCLab Orsay

20-22 april 2026
Auditorium P. Lhemann
Building 200

 **IJCLab**
Irène Joliot-Curie
Laboratoire de Physique
des 2 Infinis

 **CNRS** NUCLEAIRE
& PARTICULES

 **université
PARIS-SACLAY**
Université
Paris Cité

INTRODUCTION

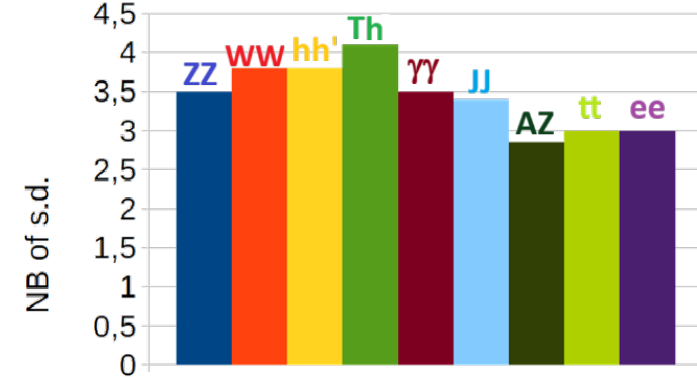

- For many years there has been growing evidence for indications around 650 GeV both in ATLAS and CMS
- Presently there are **9 such indications, each reaching ~3 sd**. When statistically combined they give a **global evidence ~6 sd** ! RUN3 should allow to reach individually 5 sd for some of them
- Coming after the 750 GeV episode, they provoke, at best, polite skepticism
- Today we come to the conclusion that the alleged 750 GeV in 2 photons first seen by ATLAS belongs to the same family, the shift in mass being presumably due to a **mis-calibrated detector + an initial positive fluctuation** in the ATLAS sample

What is it ?

- Interpretations of this effect went through different phases but, at present, the best interpretation of these indications is given by the **Randall Sundrum** model

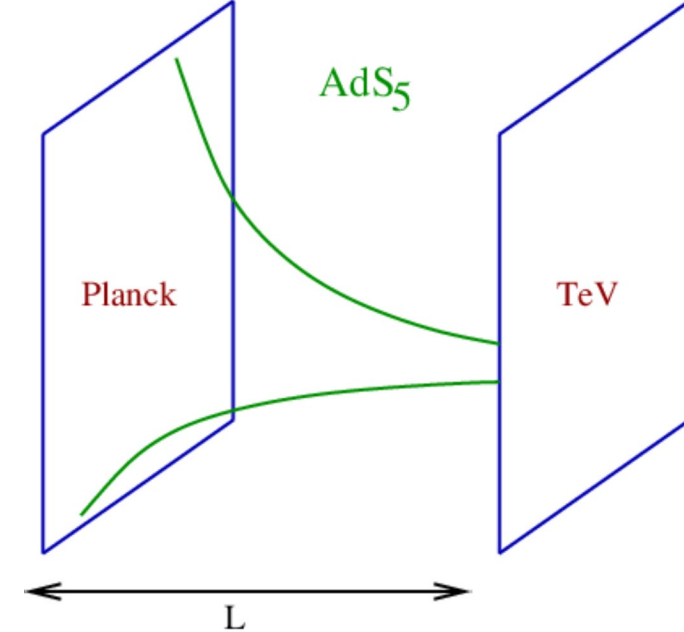

- However it is fair to add that various observations do not coincide with the strict predictions of this model, in particular the **absence of coupling to gluons** which considerably reduces the production rate for this resonance and explains that it takes so long to reach a full confirmation in spite of its low mass
- We understand the reason for this absence, invoking the classical **dual picture** where the RS 5D is dual to a 4D world where resonances are **composite objects**. In this picture the SM Higgs is itself made of colorless partons which therefore do not couple directly to gluons. The same would be true for KK gravitons which can only couple to gluons through top loops

References

[1] New resonances at LHC

Alain Le Yaouanc (IJCLab, Orsay), François Richard (IJCLab, Orsay) (Jun 11, 2025)

e-Print: 2506.09490

[2] $X_{650} \rightarrow ZZ/WW/H_{125}H_{95}/A_{450Z}$ -- scalar, tensor or both ?

Alain Le Yaouanc (IJCLab, Orsay), (IJCLab, Orsay), François Richard (IJCLab, Orsay) (Aug 22, 2024)

Contribution to: 3rd ECFA workshop on e+e- Higgs, Electroweak and Top Factories

e-Print: 2408.12178

[3] Triple Higgs coupling

Alain Le Yaouanc (IJCLab, Orsay), (IJCLab, Orsay), François Richard (IJCLab, Orsay) (Apr 15, 2024)

Contribution to LCWS24

e-Print: 2404.09827

[4] As a consequence of $H(650) \rightarrow W+W-/ZZ$, one predicts $H_{++} \rightarrow W+W+$ and $H_{+-} \rightarrow ZW+$, as indicated by LHC data

Alain Le Yaouanc (IJCLab, Orsay), François Richard (IJCLab, Orsay) (Aug 23, 2023)

Contribution to: 2nd ECFA Workshop on e+e- Higgs/EW/Top Factories

e-Print: 2308.12180

[5] Searches for scalars at LHC and interpretation of the findings Anirban Kundu (Calcutta U.),

Alain Le Yaouanc (IJCLab, Orsay), Poulami Mondal (Calcutta U.), François Richard (IJCLab, Orsay)

Contribution to 2022 ECFA Workshop on e+e- Higgs/EW/TOP factories

e-Print: 2211.11723

The two photon story

Yesterday: 750 GeV wide

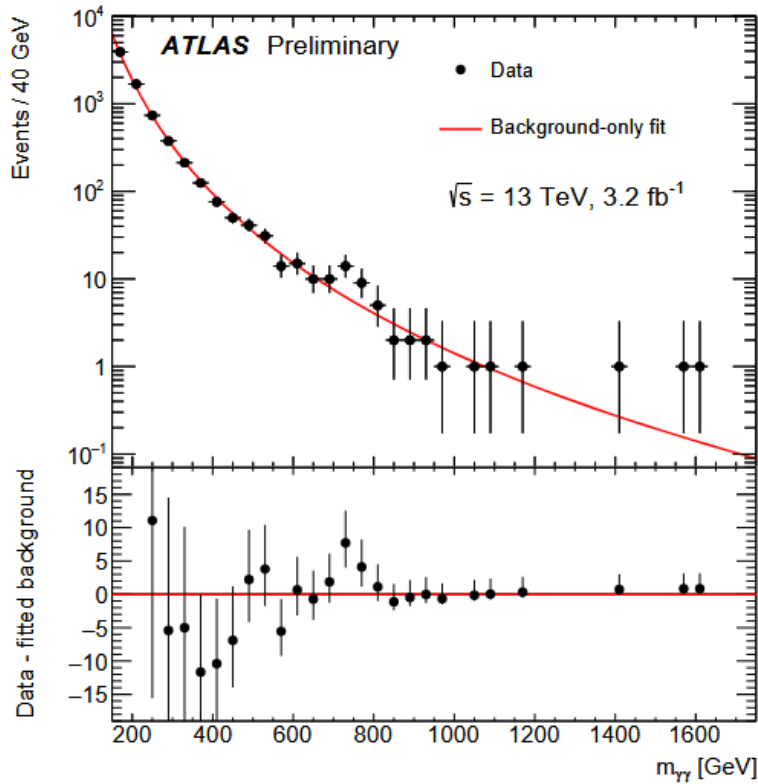

[ATLAS-CONF-2015-081](#)

Today: 690 GeV narrow

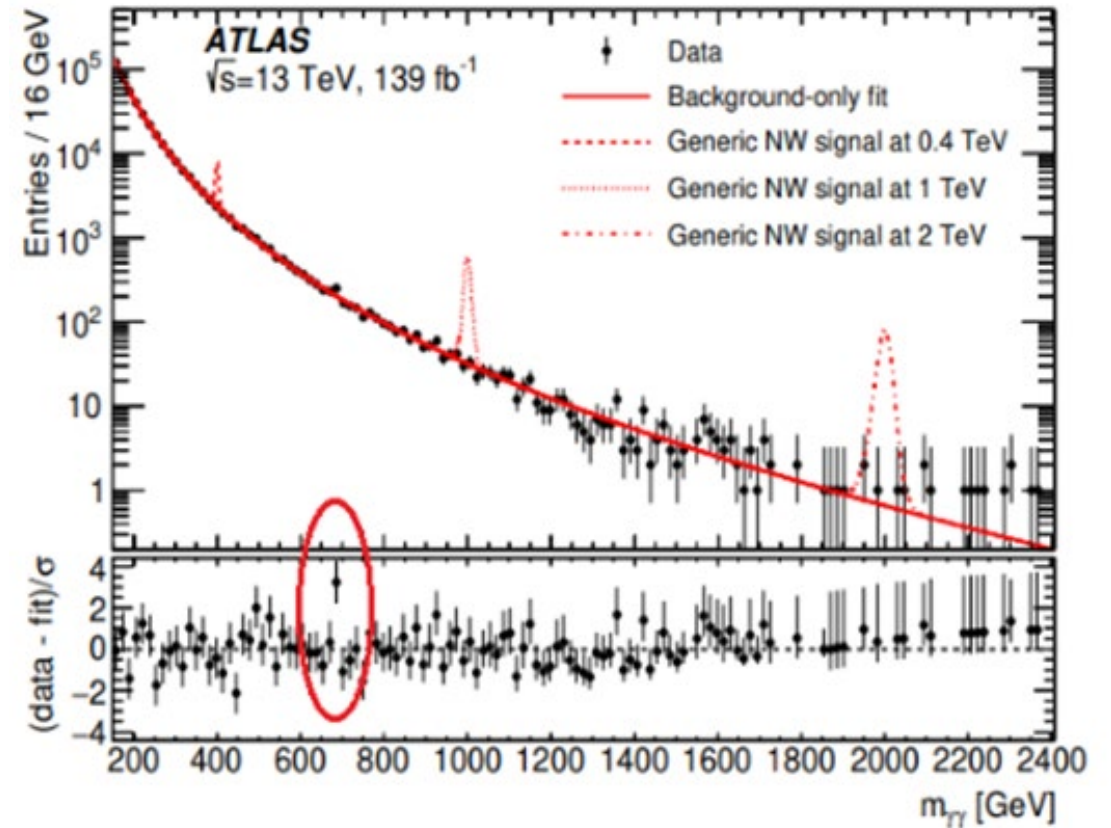

F. Richard IJCLAB April 2026

[2102.13405](#)

X650 \rightarrow ZZ \rightarrow $e^+e^-e'^+e'^-$ J=2 or J=0 ?

- Naive cut based analysis

- Selecting a scalar against DY

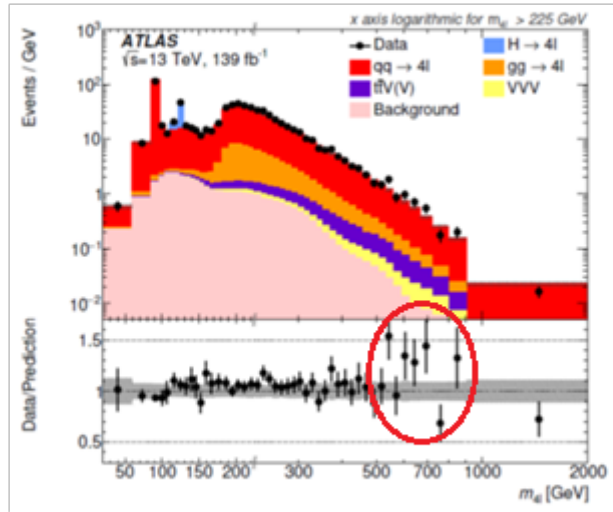

ggF+VBF

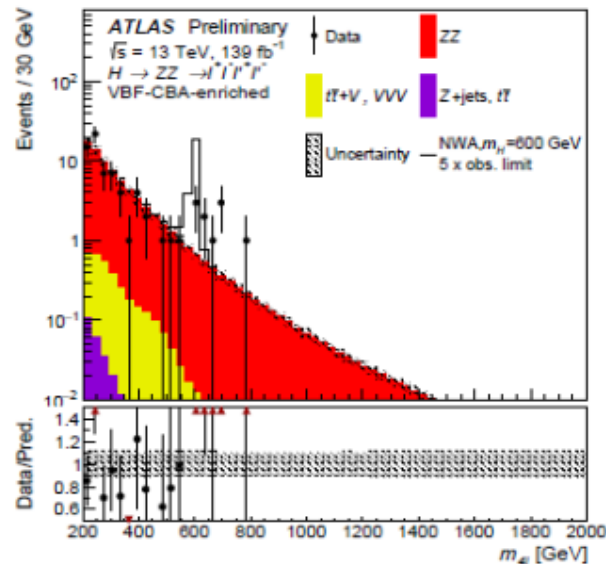
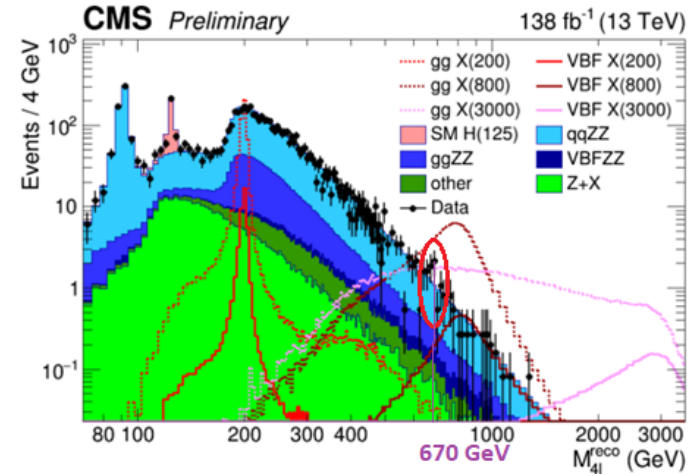

VBF

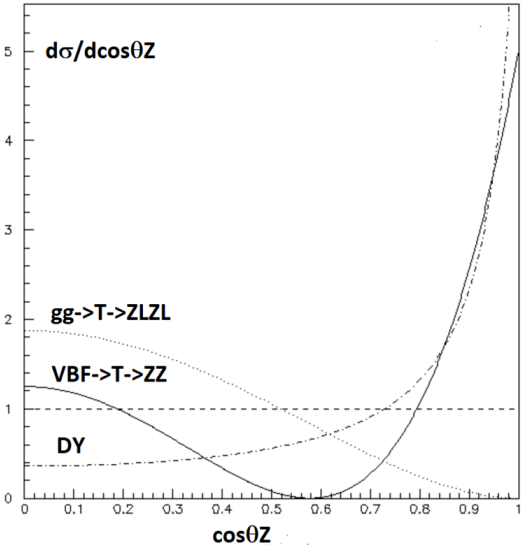
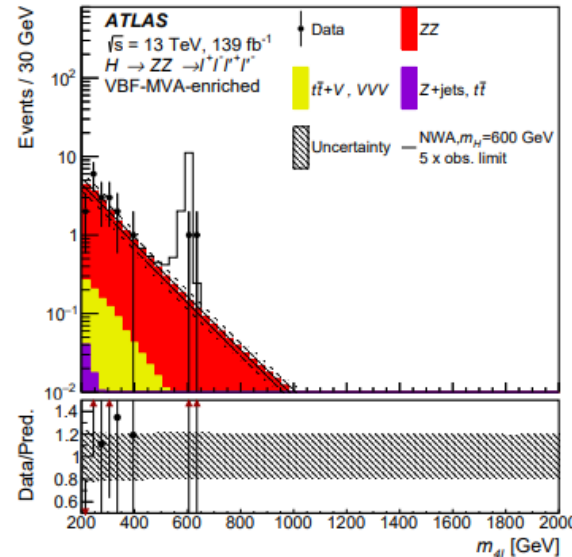

Only produced through VBF

- Both ATLAS and CMS loose the **ZZ channel** with scalar selections even w/o the VBF selection
- ggF should not suffer from a scalar selection !
- Same observation in the **WW channel** by CMS which concludes that this signal comes mainly from VBF and not from ggF
- Goes against RS standard predictions !
- Invalidates mass limit from ATLAS
- Explains why we need so much luminosity to observe a sub-TeV resonance

[2009.14791](#)

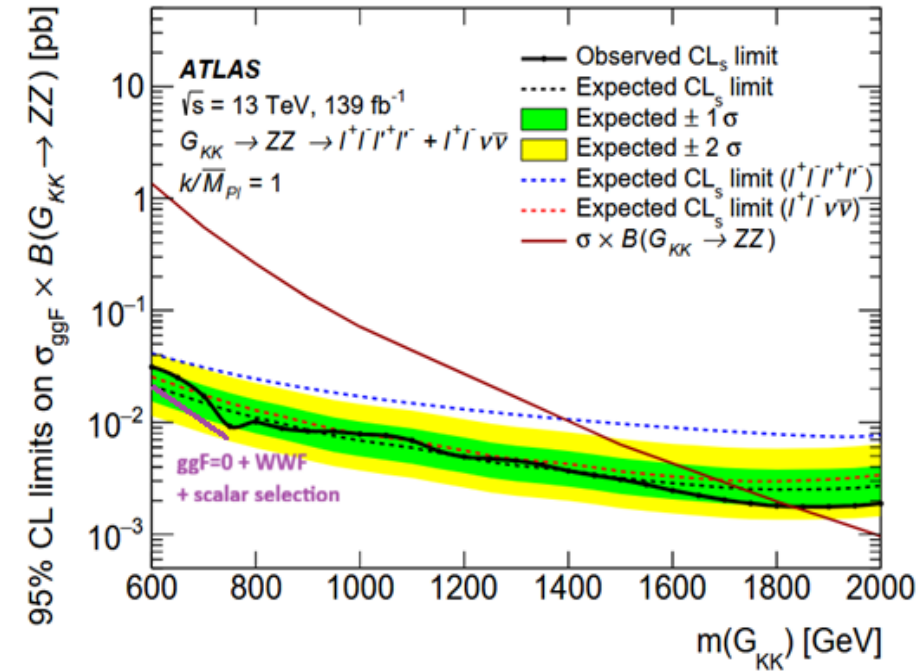

RS predictions

- RS predicts: **T376 T690 T1100 GeV** given by zeros of **Bessel function** (geometry)
- We have 5 indications compatible with T376 hence a significance of ~ 4 s.d.
- Explains the **width of T690 ~ 20 GeV** instead of ~ 3 GeV for T376
- Indication in **hh at 1000 GeV** from ATLAS
- **Perturbative unitarity** predicts that there could be **W^+W^+ and ZW** resonances to avoid early violation which seems true for the first sequence **T376**

$$g^2(4m_W^2 - 3m_Z^2 c_W^2)^{\rho \approx 1} \simeq g^2 m_W^2 = \sum_k g_{W^+W^-H_k^0}^2 - \sum_l g_{W^+W^+H_l^-}^2$$

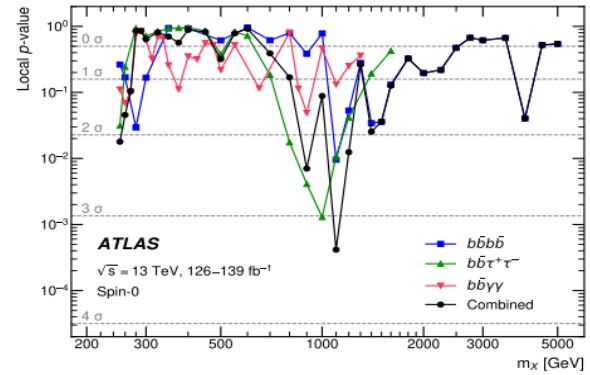
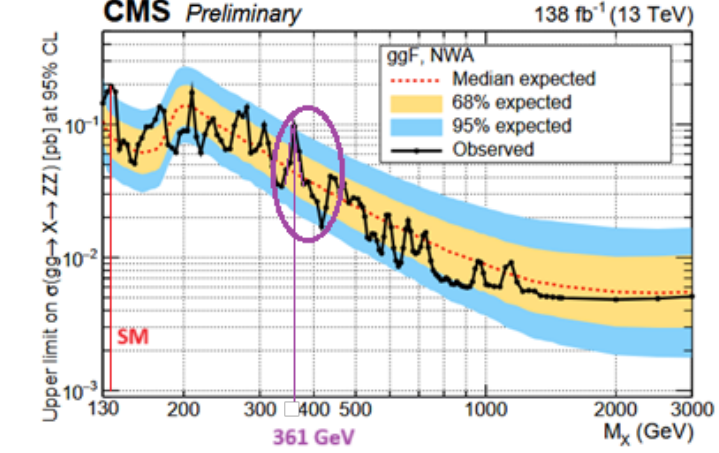

Phys. Rev. Lett. 132 (2024) 231801

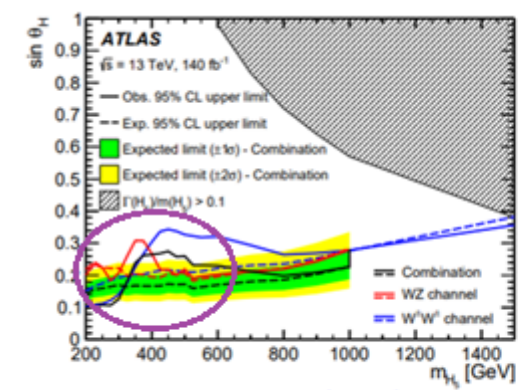
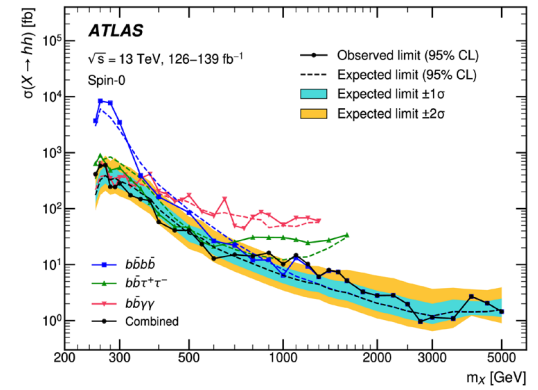

Phys. Lett. B 860 (2025) 139137

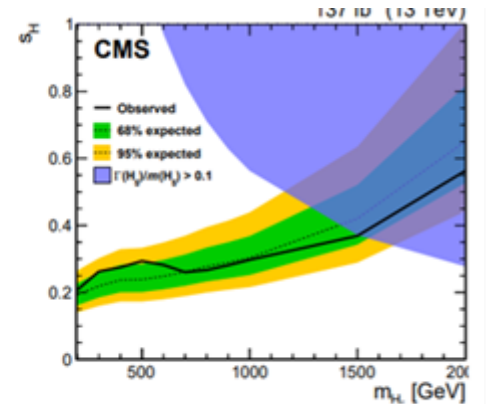

Eur. Phys. J. C 81 (2021) 723

Other evidences for 650 GeV

[2509.01219](#)

CERN-EP-2025-194, in submission

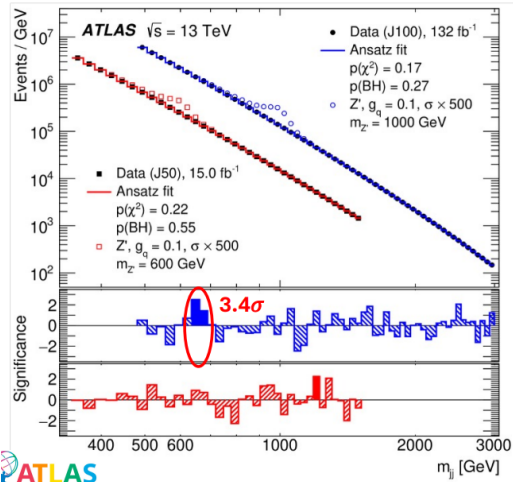

X650->2 Jets

[CMS-PAS-HIG-20-012](#)

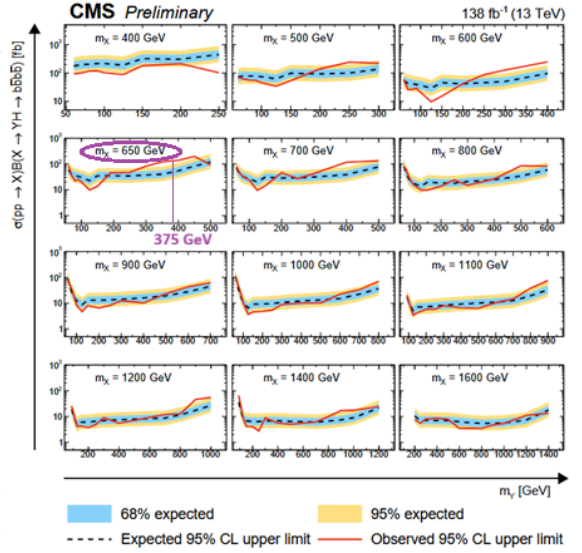

X650->Y375+h125->bb+bb

[2310.01643](#)

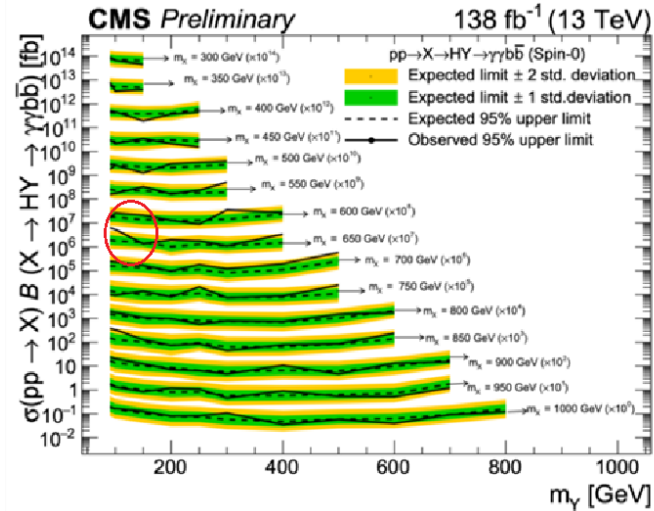

X650-> h125h95 -> $\gamma\gamma$ + bb

[2505.23012](#)

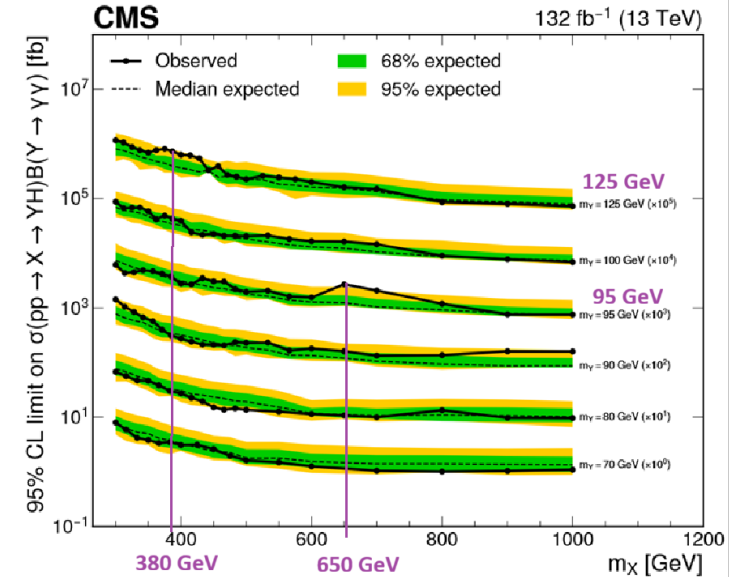

X650-> h125h95 -> $\gamma\gamma$ + $\tau\tau$

T376-> h125h125-> $\gamma\gamma$ + $\tau\tau$

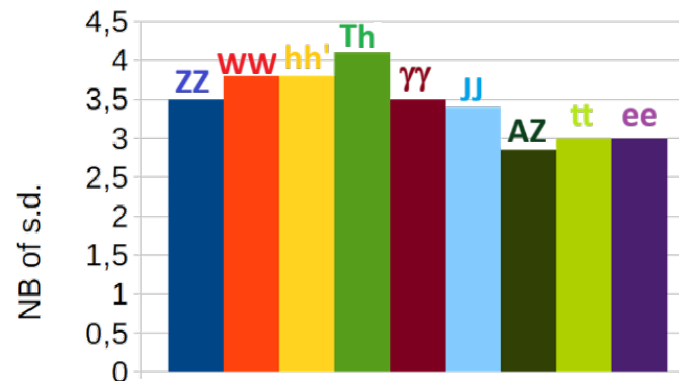

Open questions

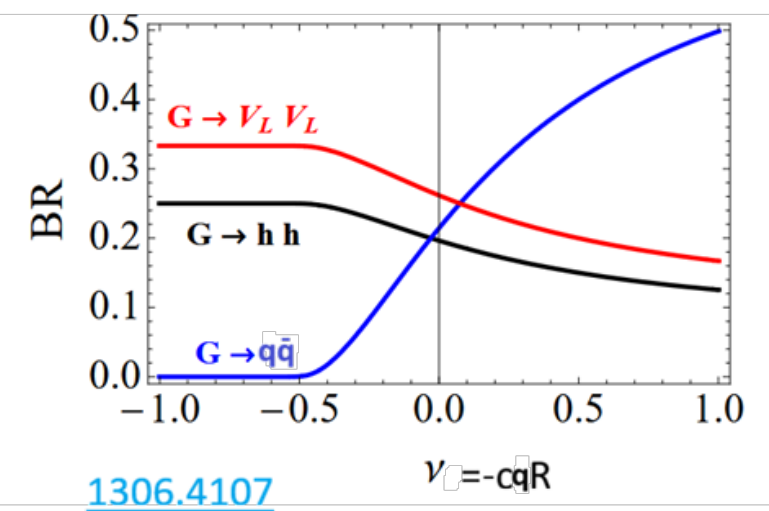
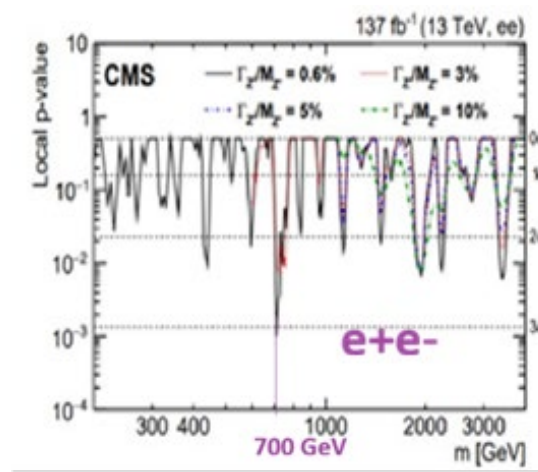

- Where are the other KK states like Z_{KK} etc... ?
- Two mechanisms are proposed to explain why G_{KK} could be the lightest KK state [1603.06980](#) [2506.09490](#)
- Is it coupled to e+e- ? $BR(G_{KK} \rightarrow ee) = 0.25\%$ from ATLAS/CMS is compatible with $\sin^2\theta_{eff}$ from LEP/SLD if Z_{KK} is much heavier than G_{KK}
- Essential point: $BR(ee) \sim 0.25\%$ would predict **Giga graviton factories** at e+e- colliders

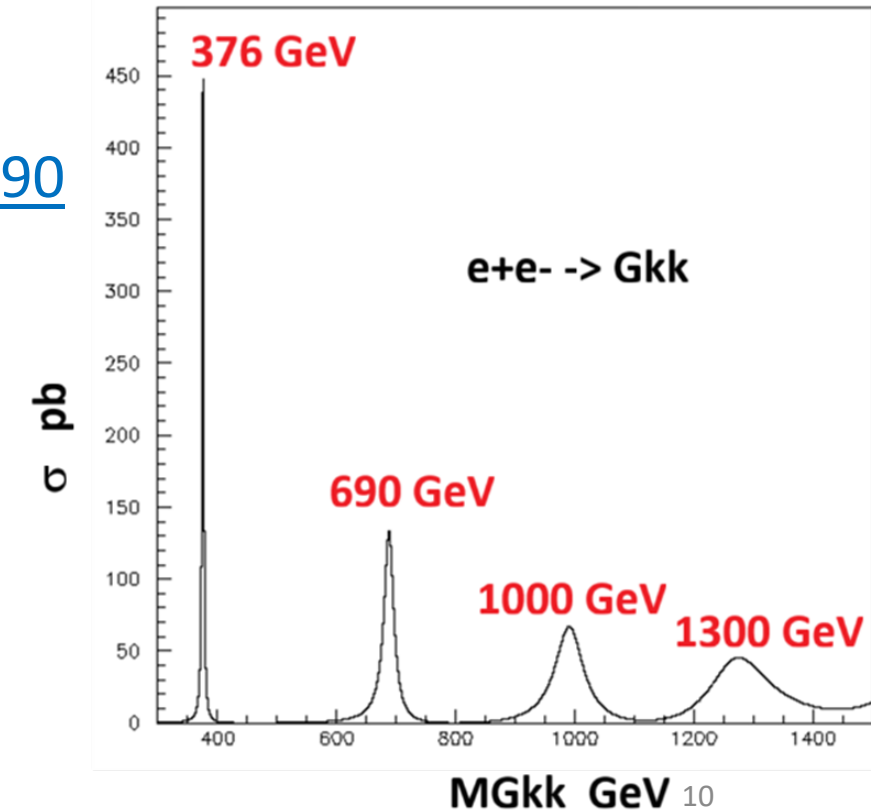

SUMMARY

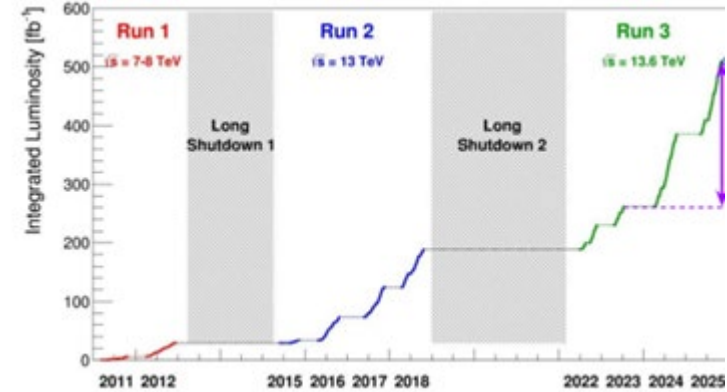

- '650' and '750' are probably not distinct !
- ZZ and WW suggest a **J=2 state** produced by **VBF** with seven more indications
- This resonance is accompanied by two other indications which suggest the **RS sequence T376 T690 T1000** which provides an explanation for the width and strengthen our interpretation
- Absence of coupling to **gluons** suggest G_{KK} is a **composite particle** made of **colorless partons** similarly to the Higgs boson
- T376, accompanied by T++ and T+, allows to push **perturbative unitarity limit > 29 TeV**
- To interpret LEP precision measurements and **BR(ee)~0.25%** KK gravitons should be much lighter than KK Z
- Implies **Gigafactories for e+e- colliders with ECM>400 GeV**
- **RUN2+RUN3** should provide enough data to confirm/reject this signal and its interpretations

Acknowledgements

- Thanks to **Andreas Höcker** and **Gautier Hamel de Monchenault** for their encouragements in this task
- Useful and pleasant exchanges with **Abdelhak Djouadi**, **Ulrich Ellwanger**, **Adam Falkowski** and **Gilbert Moulta** are gratefully acknowledged
- Thanks to **Roman Poeschl**, **Guillaume Unal** and **Louis Fayard** for useful exchanges
- Thanks to **Kaustub Agashe** and **Severin Lüst** experts on the RS model

Additional slides

LEP precision measurements

- In the RS model Z_{KK} can influence LEP PM
- AFB_b, ALR show signs of deviations which can be fixed within a LR extension of the RS model
- So far a KK mass of **0.3TeV/sinθ'** was assumed, with $\sin\theta' > 0.1$, see [0610173](#), hence **ceR=0.56** which gives a negligible BR($G_{KK} \rightarrow ee$)
- If this mass is of order 2.5TeV/sinθ', ALR implies that **ceR=0.45**
- This implies **BR(ee)~0.25%** compatible with ATLAS and CMS as suggested by the figure from [1306.4107](#)

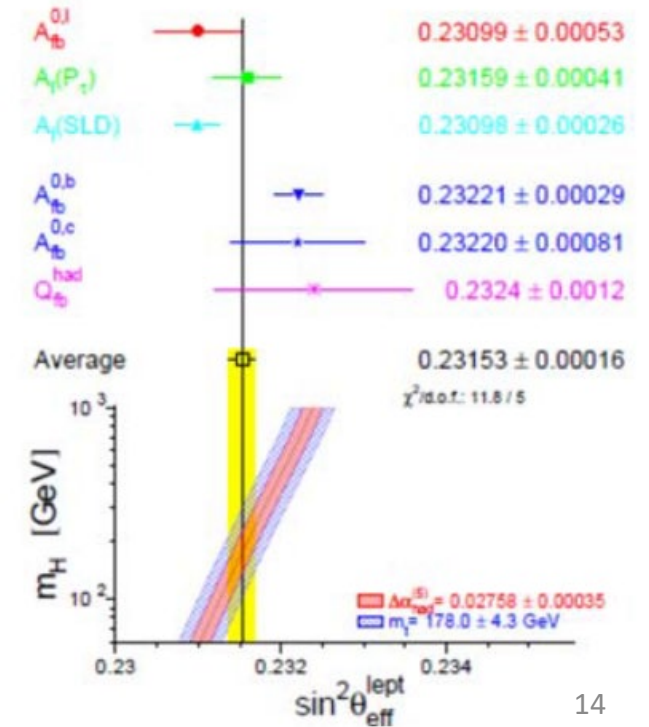
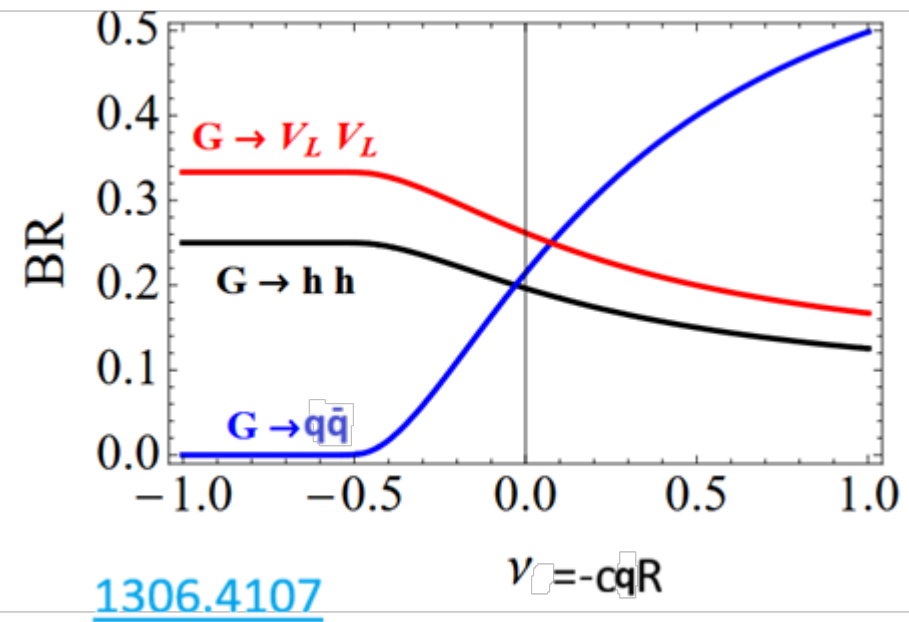

Why is G_{KK} much lighter than Z_{KK} ?

- In [1603.06980](#) a mechanism is recalled where bulk fields develop localized corrections to the **kinetic terms** which can modify the phenomenological predictions
- **Large brane kinetic terms** allows to create a hierarchy between the diverse KK families
- A more radical way out is to invoke an **analogue of the Higgs mechanism**. As longitudinal degrees of freedom of Z and W come from the SM Higgs doublet, the additional degrees of freedom for the massive graviton KK modes (5 in the massive vs 2 in the massless case) would come from one vector and one scalar KK mode. Experimentally, these “eaten” vectors and scalar degrees of freedom are not visible as individual particles. The same thing could also happen for the fermionic KK modes in a SUSY theory. They can become the missing degrees of freedom of the massive gravitino KK modes.
- We are indebted towards Severin Lüst for suggesting this mechanism.

CMS on $G_{KK} \rightarrow 2\gamma$

- ATLAS has found a xsection of ~ 2 fb at ~ 700 GeV
- This result is not incompatible with the limit given by CMS in EXO-22-024

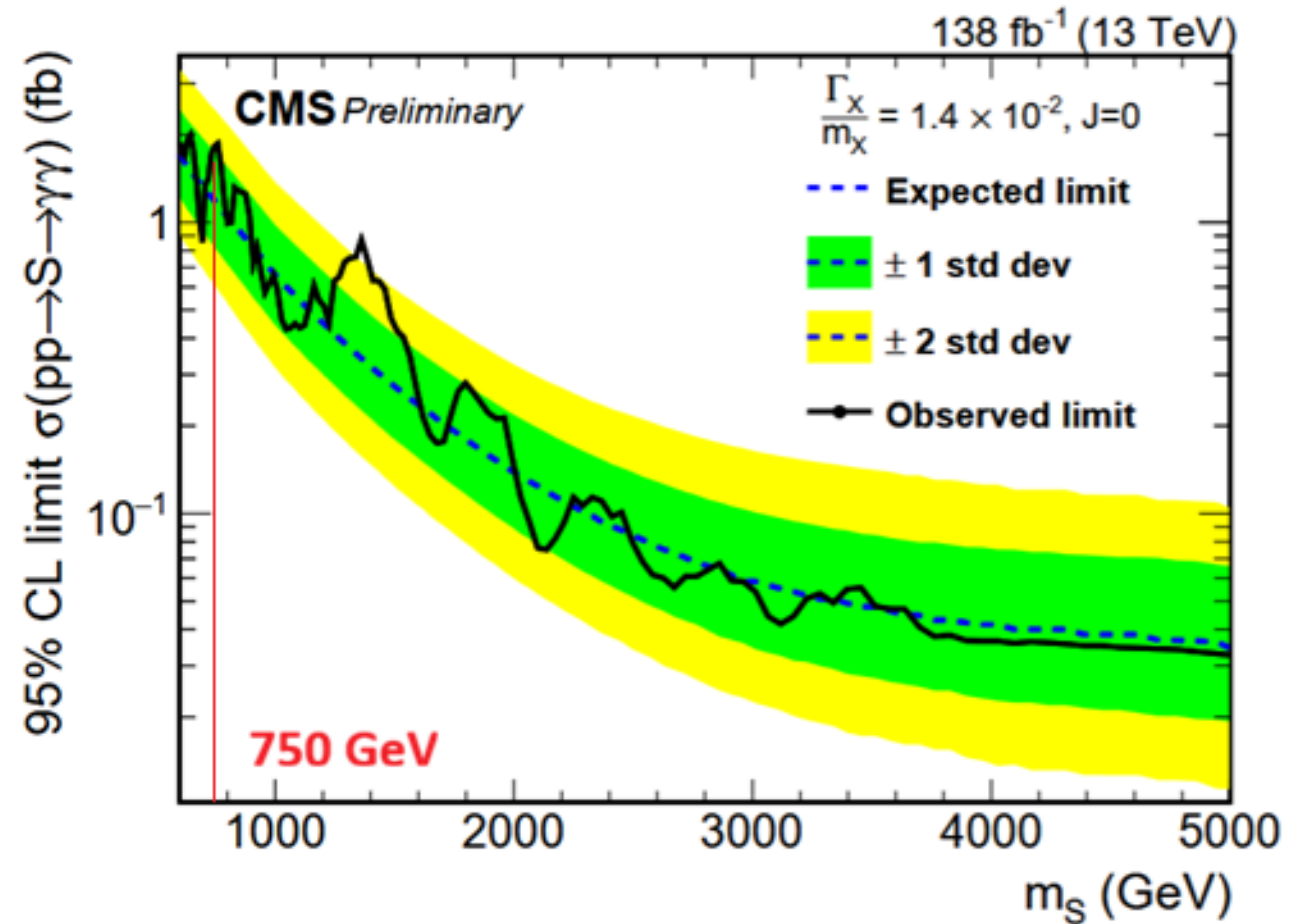

Sum Rules

- **Perturbative Unitarity** requirements predict sum rules for **scalar couplings**
- $W_L^+ W_L^- \rightarrow W_L^+ W_L^-$ Haber et al. in *P.R.D* 43 (1991) 904-912
- They are satisfied by the SM and heavy scalar doublet (decoupling) contributions
- In the Georgi Machacek model one has compensation due to H^{++} (u exchange term)

$$g^2(4m_W^2 - 3m_Z^2 c_W^2)^{\rho \simeq 1} \simeq g^2 m_W^2 = \sum_k g_{W^+ W^- H_k^0}^2 - \sum_l g_{W^+ W^+ H_l^{--}}^2$$

- KK J=2 gravitons have a **different angular distribution** but could be compensated by doubly charged tensors $T^{++} \rightarrow W^+ W^+$ giving u exchange contributions
- In the same way $ZZ \rightarrow WW$ forces us to expect $T \rightarrow ZW$
- They are indicated by LHC data for the first KK recurrence at 376 GeV
- They could also appear at 690 GeV for the second KK recurrence

Summary diagram

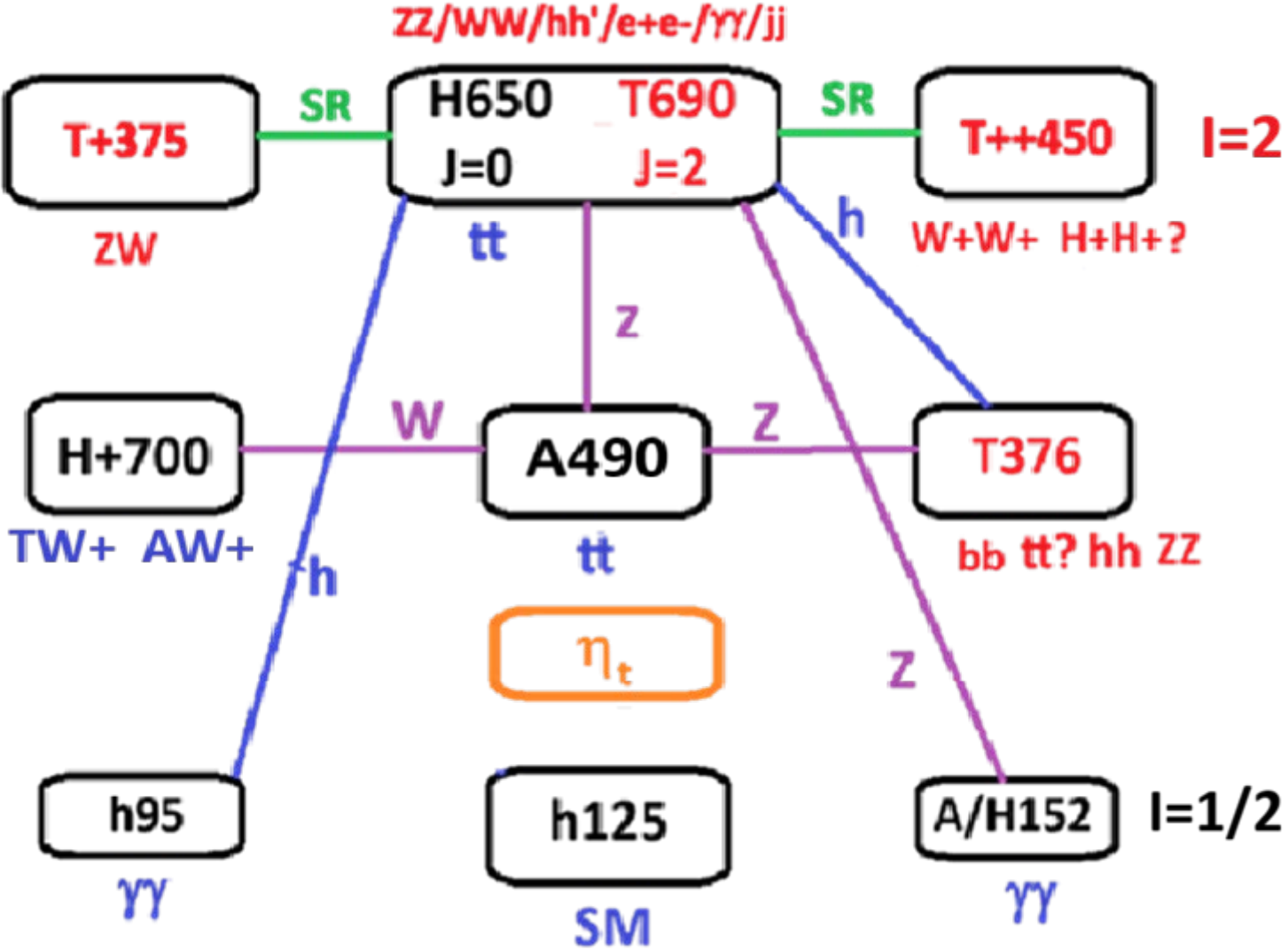

Evidences for ~ 650 GeV resonance(s)



~ 6 sd global significance

| Channel | Significance s.d. | Reference |
|---------------------------------------|---------------------|---------------------------------|
| ZZ 4 leptons | 3.8 ggF+VBF 2.8 VBF | ATLAS 2009.14791 |
| WW 2leptons | 3.8 VBF | CMS-PAS-HIG-20-016 |
| h95h125 bb/ $\tau\tau$ $\gamma\gamma$ | 3.8 | CMS 2310.01643 CMS 2506.23012 |
| T376h125 bbbb | 4.1 | CMS-PAS-HIG-20-012 |
| $\gamma\gamma$ | 3.5 | ATLAS 2102.13405 |
| JJ | 3.4 | ATLAS 2509.01219 |
| AZ tt 2leptons | 2.85 | ATLAS 2311 |
| e+e- | 3 | ATLAS 1903.06248 CMS 2103.02708 |
| tt | 3 | ATLAS 2404.18986 CMS 2507.05119 |

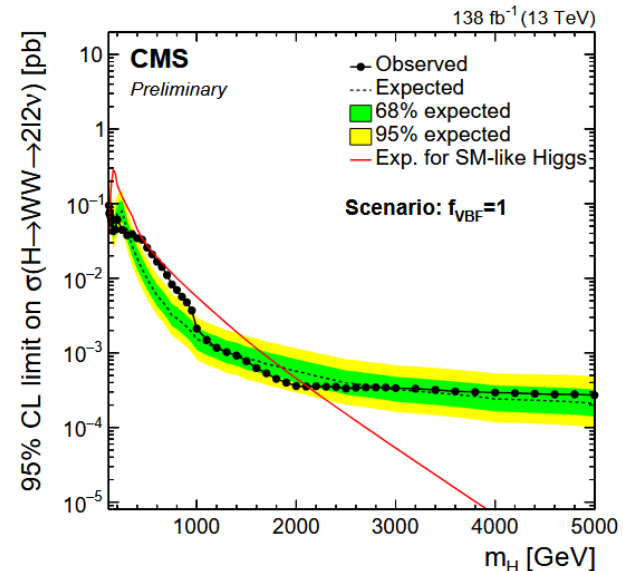
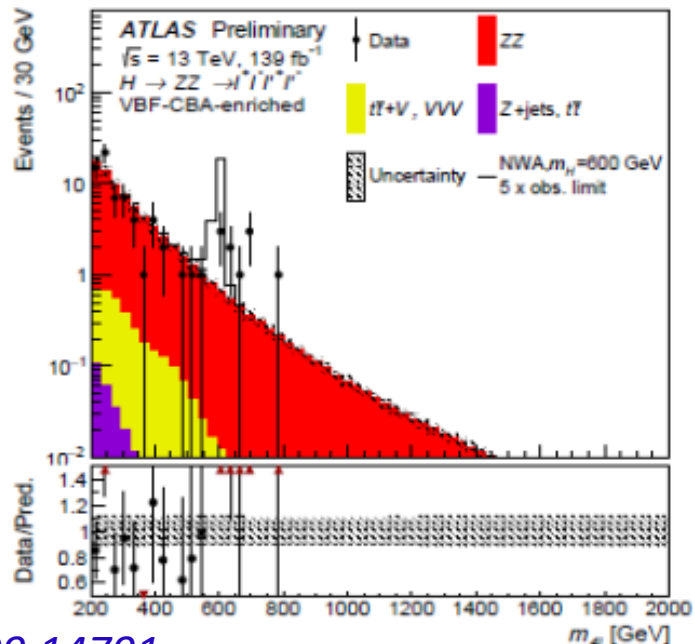
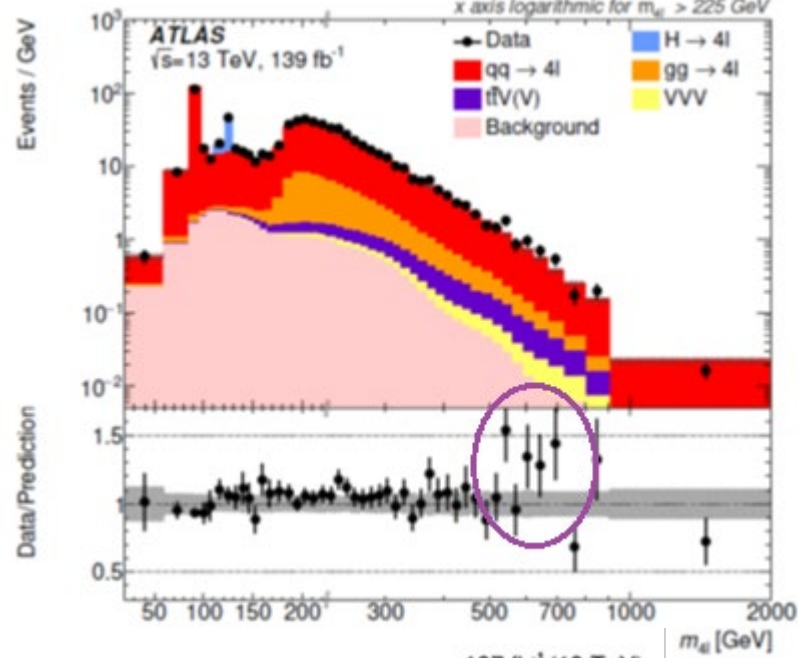

CMS-PAS-HIG-20-016

2009.14791

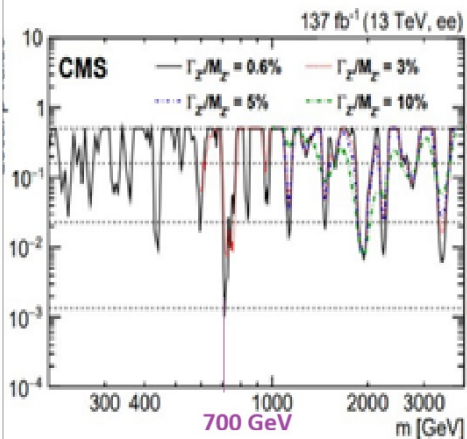
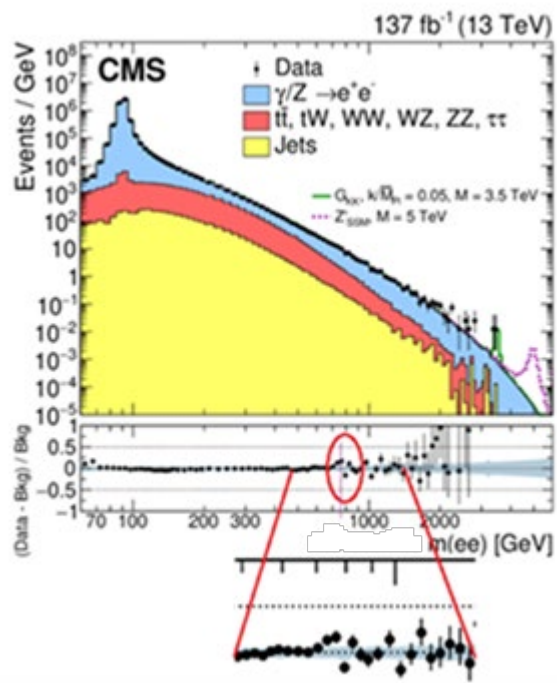

2103.02708

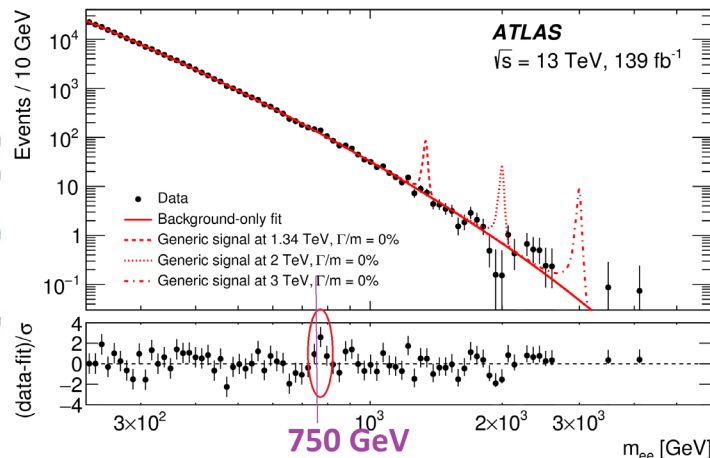

1903.06248

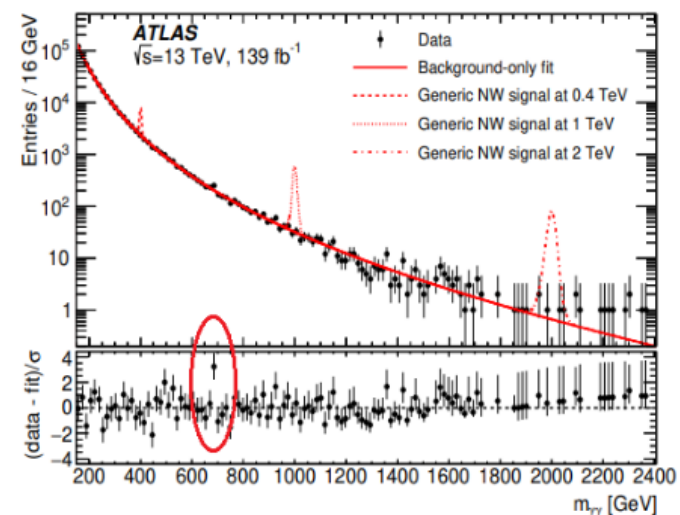

2102.13405

Complex modes

2509.01219

CERN-EP-2025-194, in submission

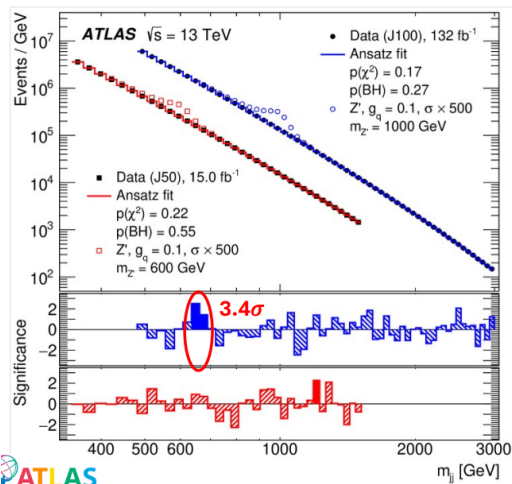

X650->2 Jets

CMS-PAS-HIG-20-012

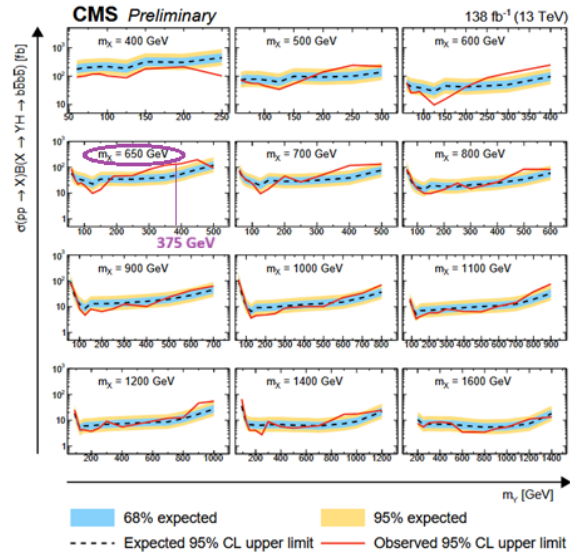

X650->Y375+h125->bb+bb

2310.01643

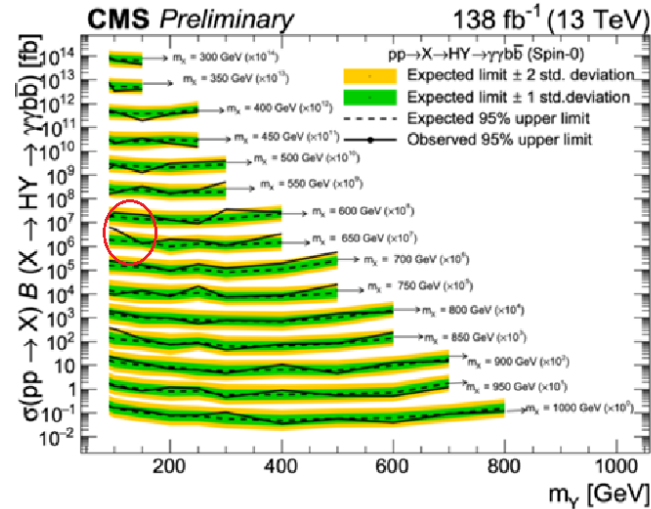

X650-> h125h95 -> $\gamma\gamma$ + bb

2505.23012

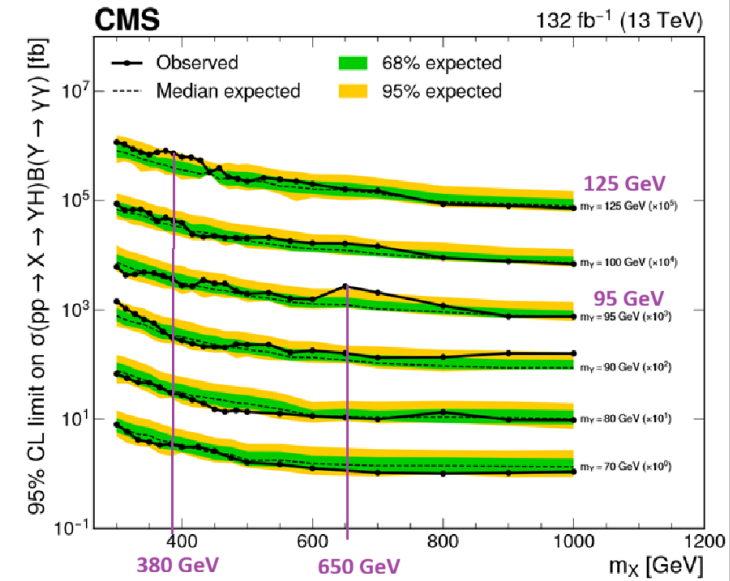

X650-> h125h95 -> $\gamma\gamma$ + $\tau\tau$

T376-> h125h125-> $\gamma\gamma$ + $\tau\tau$

Next best candidate to T690 ?

[CMS 2506.23012](#)

[2210.05415](#)

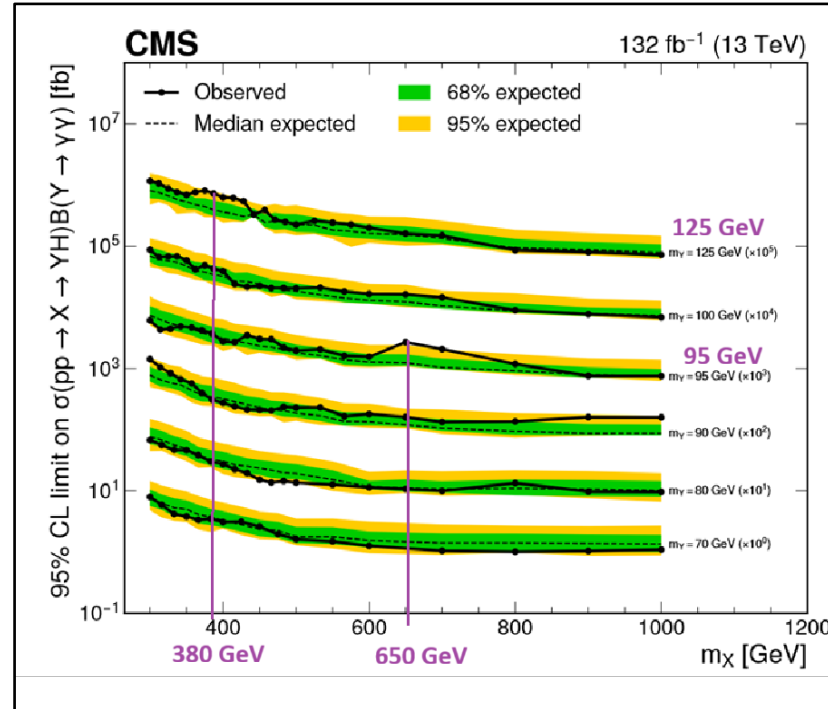
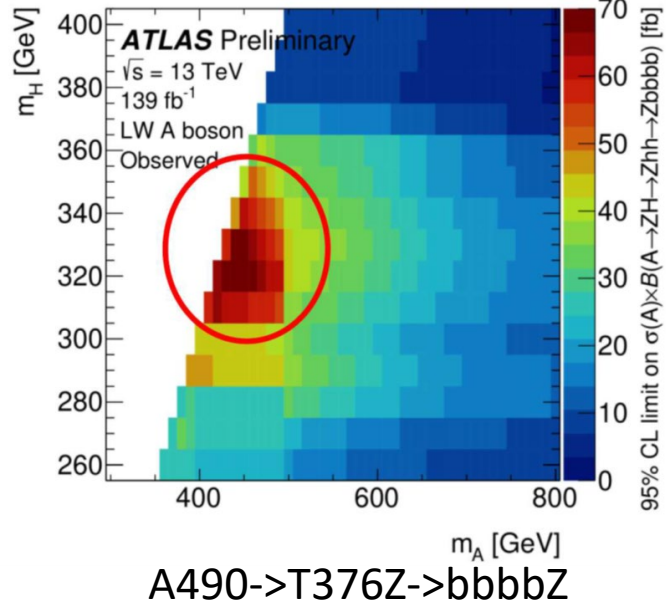

T376 \rightarrow hh \rightarrow $\tau^+ \tau^- + \gamma\gamma$

T690 \rightarrow T375h \rightarrow bb+bb

[CMS-PAS-HIG-20-012](#)

[2210.05415](#)

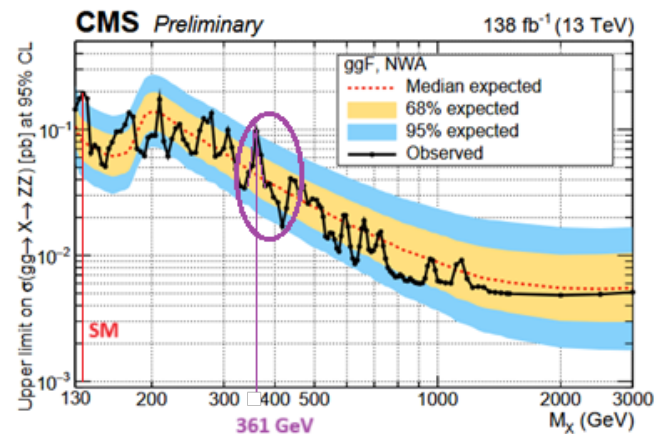
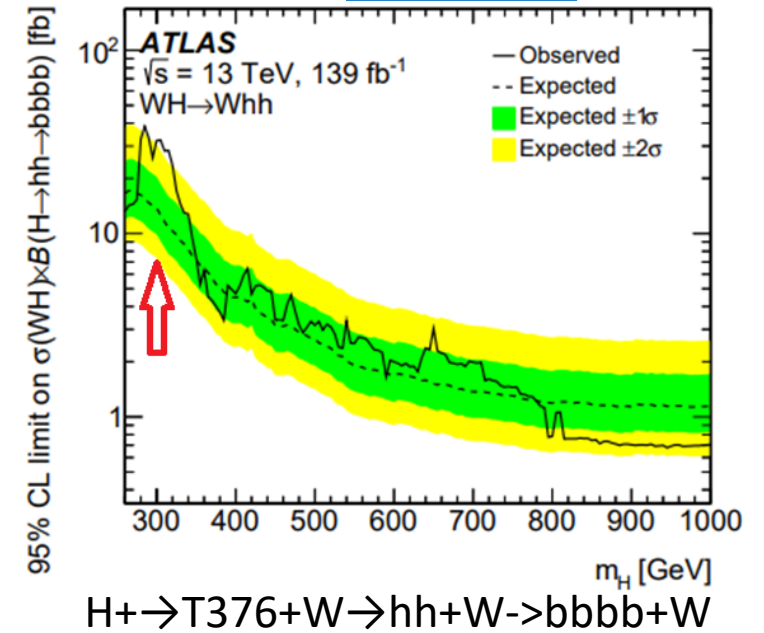

T376 \rightarrow ZZ \rightarrow $l^+ l^- l' + l'^-$

[CMS-PAS-HIG-24-002](#)

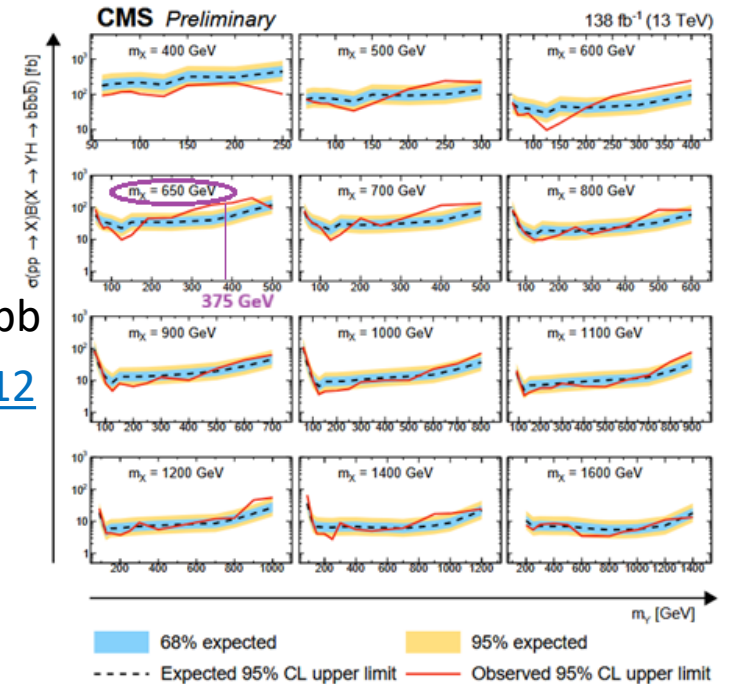

CMS results

<https://cds.cern.ch/record/2114808/files/EXO-15-004-pas.pdf>

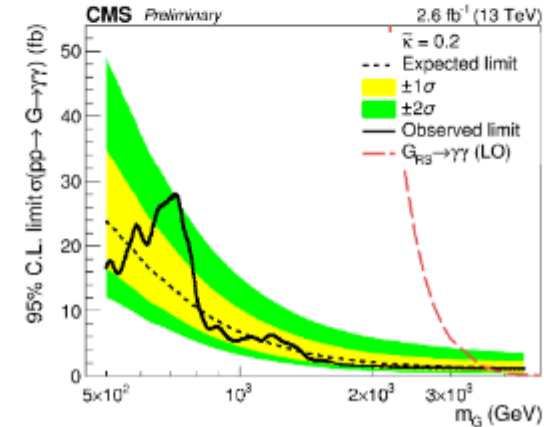
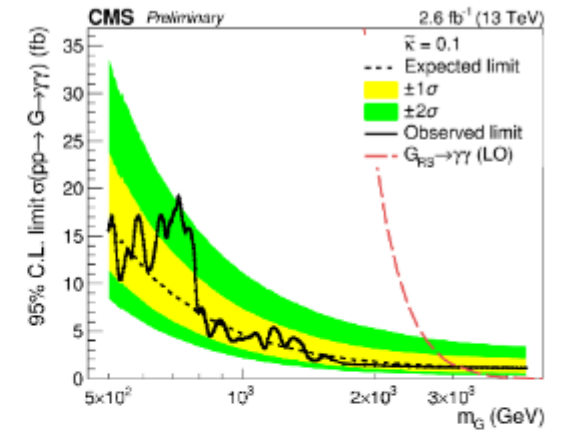
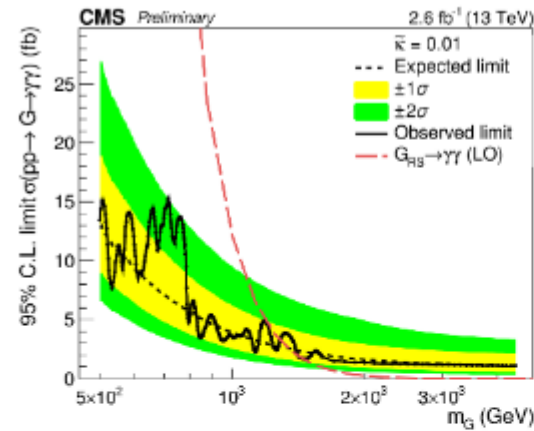
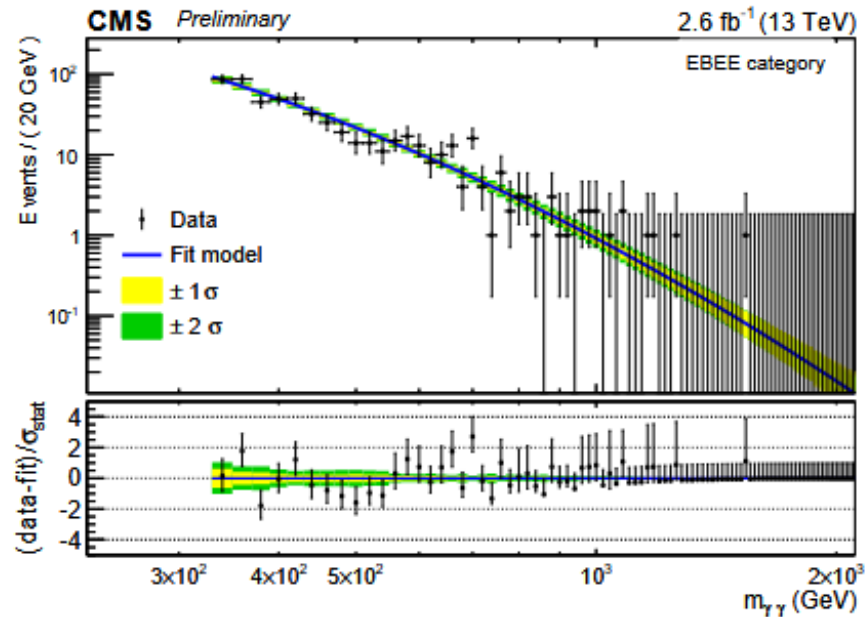
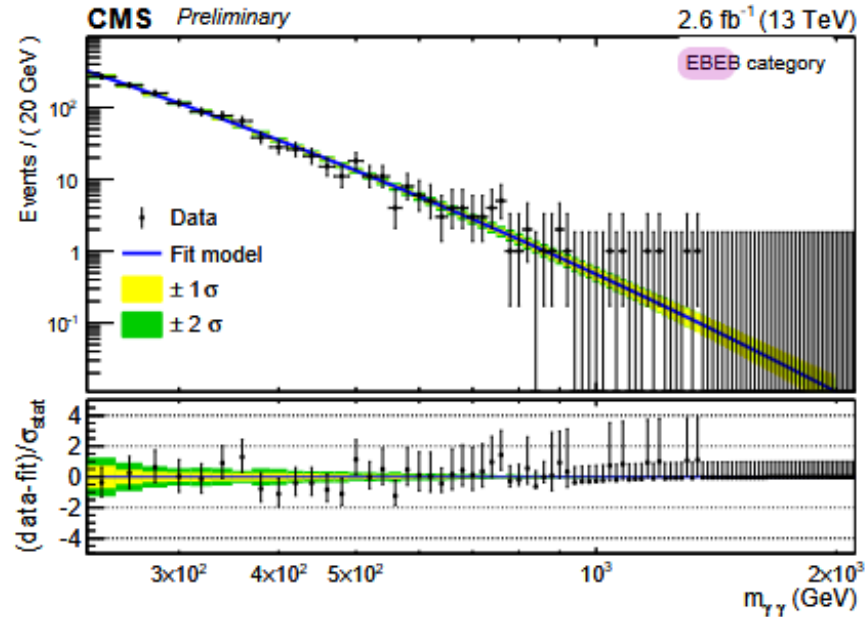

Graviton recurrences ?

- T690 seems a valid tensor candidate
- In the Randall Sundrum (RS) model, graviton KK resonances G_{iKK} have masses which go like $m_i \sim 100x_i^G$ in GeV, where $x_i^G = 3.8, 7.0, 10.2, 13.3 \dots$ and widths which go like $\Gamma \sim 0.06(x_i^G)^3$
- These numbers which govern the RS model are of **geometric origin**, simply given by the zeros of the Bessel function $J_1(x)$
- Assuming that **T690 is the second KK resonance**, one predicts **T376** as the first one, as observed and the third one **T1000**, which seems indicated by ATLAS searches for $h_{125}h_{125}$
- The next one should be T1300

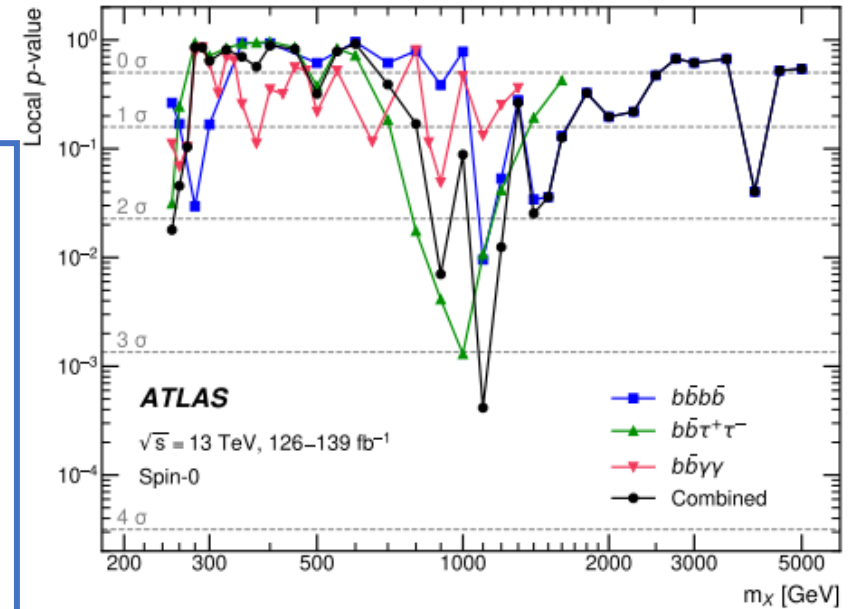

Phys. Rev. Lett. 132 (2024) 231801

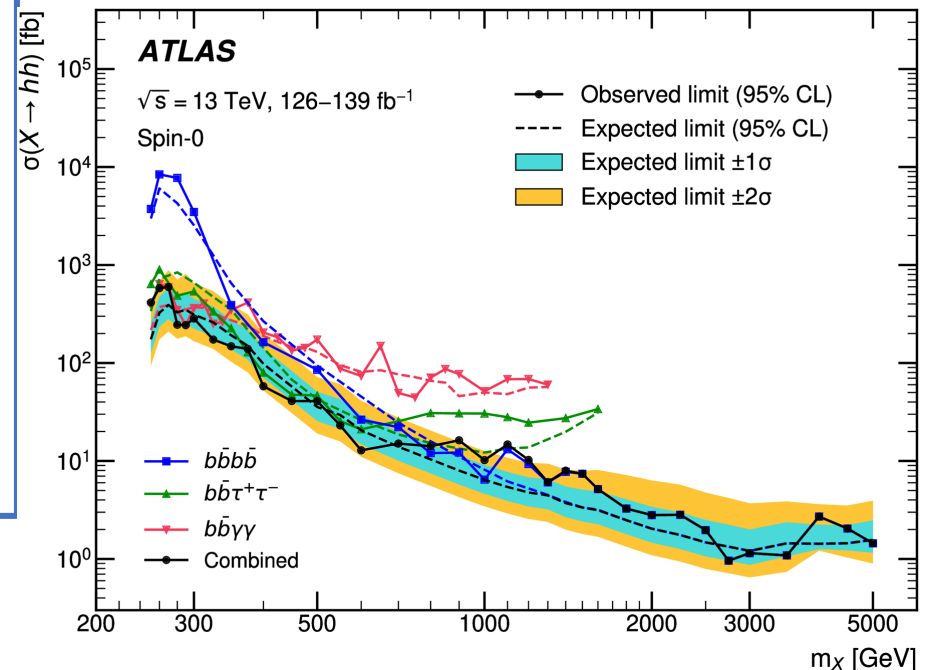

A preliminary interpretation of these indications

J=0
I=1/2

J=2
I=2

| HD1 | h125 → SM | WL | ZL |
|------------|---|--|---|
| HD2 | h95 → 2 γ | t → H⁺130 b → bcb | A152 → 2 γ +Z/W |
| HD3 | H650 → A490Z → ttZ | H⁺700 → A490W⁺ | A490 → T376Z → hhZ |
| TQ1 | T⁺⁺450 → W⁺W⁺ | T⁺375 → ZW⁺ | T376 → hh,bb,tt |
| TQ2 | T690 → ZZ/WW/h125h95/tt/2γ/e+e- | | |
| TQ3 | T1000 → ZZ/WW/h125h125 | | |

Weinberg Model
Gauge Theory of CP violation, Phys. Rev. Lett, 37 (1976) 657.

Randall Sundrum
MTQ1=376
MTQ2=690
MTQ3=1000

Effective Field Theory: Why and why not?

- No signs for NP at LHC thus far

- Most likely: $\Lambda_{NP} \gtrsim 1 \text{ TeV}$

- Expansion in: $v^2/\Lambda_{NP}^2 \ll 1$

- Effective Field Theory (EFT):**

- Model independent

- Valid at energies E below Λ_{NP}

- But:**

- How small does E/Λ_{NP} need to be?
Validity for (non-)resonant processes?

- Huge number of free parameters
⇒ Analysis with all couplings
unfeasible

- ⇒ EFTs: powerful but complicated

$H^{++} \rightarrow W+W+$

$X \rightarrow WZ$

ATL-PHYS-PUB-2023-008

ATLAS Heavy Particle Searches* - 95% CL Upper Exclusion Limits

Status: March 2023

ATLAS Preliminary
 $\sqrt{s} = 13 \text{ TeV}$
 $\int \mathcal{L} dt = (3.6 - 139) \text{ fb}^{-1}$

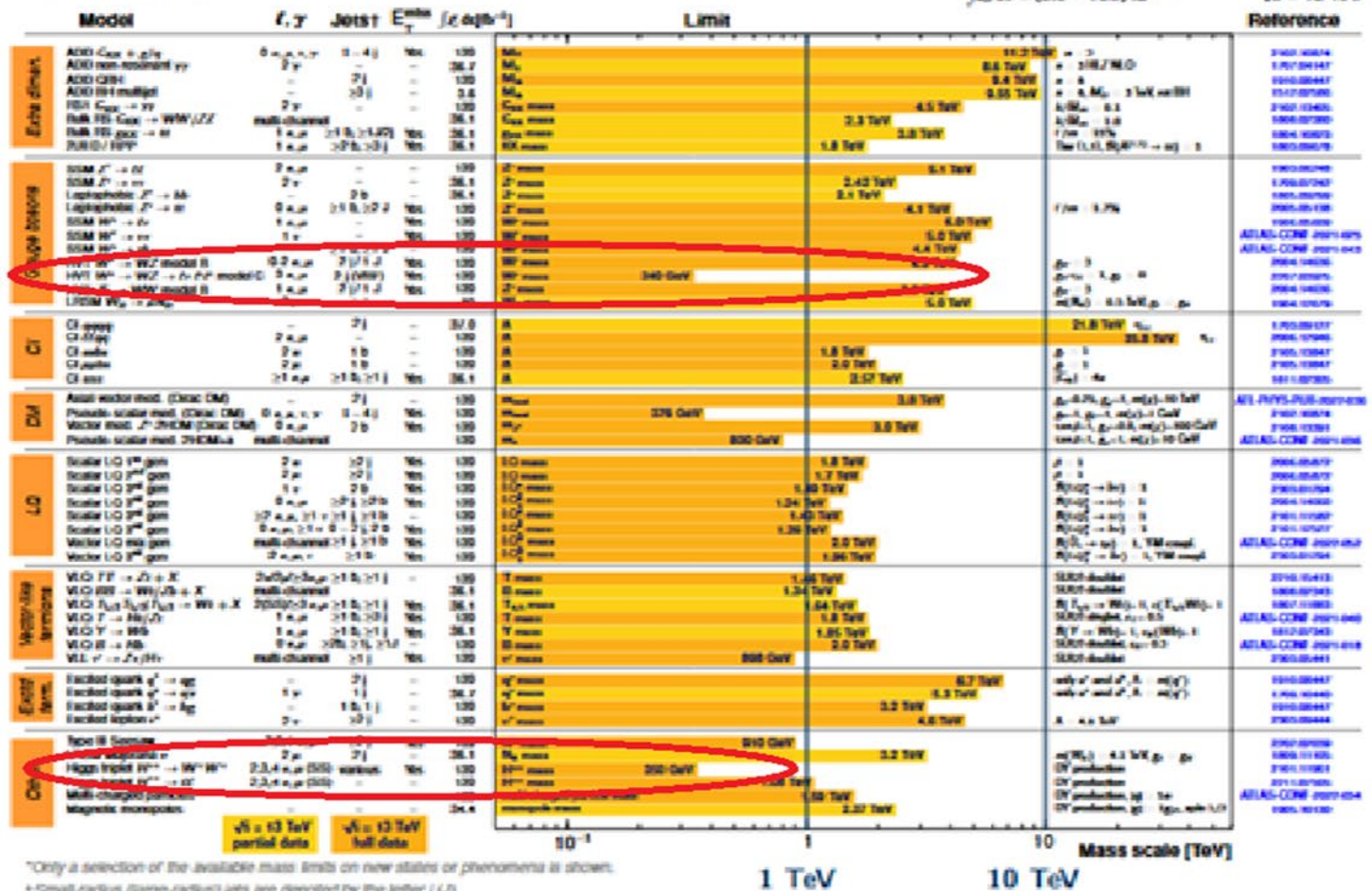

entering the attobarn era

Michi Hostettler Moriond 2026

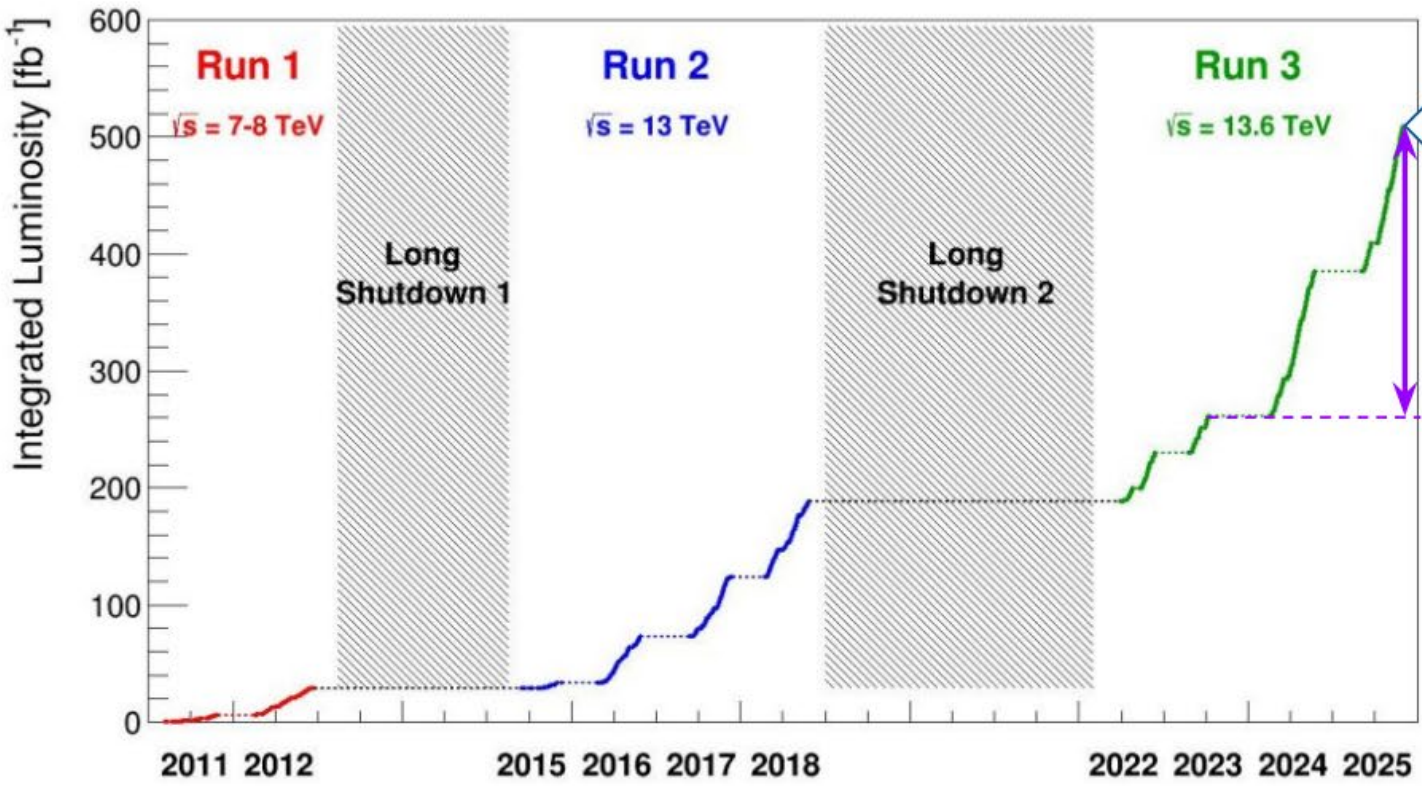

0.51 ab⁻¹
("x2" for ATLAS + CMS)

~50% of which delivered in the past 2 years...



+30 fb⁻¹ in 2026