



Franck LEGRAND

New member of the mechanical team

Biennale 2026



**189 permanent staff**  
137 researchers, 52 ITA

**Arrived in 2009**

**5 years**

**Nanosciences field - Lyon 1 – INP**



**189 permanent staff**  
137 researchers, 52 ITA

**Arrived in 2009**

**5 years**

**Nanosciences field - Lyon 1 – INP**



**82 permanent staff**  
56 researchers, 26 ITA

**7 years**

**Mechanical field - INSA de Lyon – INSIS**



**189 permanent staff**  
137 researchers, 52 ITA

**Arrived in 2009**

**5 years**

**Nanosciences field - Lyon 1 – INP**



**600 permanent staff**  
260 researchers, 340 ITA

**3 years**

**Paris Saclay - IN2P3**



**82 permanent staff**  
56 researchers, 26 ITA

**7 years**

**Mechanical field - INSA de Lyon – INSIS**



**High-pressure team**

**and**

**Microfluidic team**

# High-pressure diamond anvil cell - piezo vibrator under transmission microscope

Prof. Alfonso San Miguel

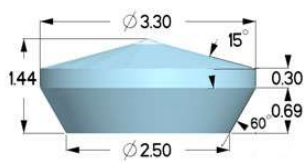
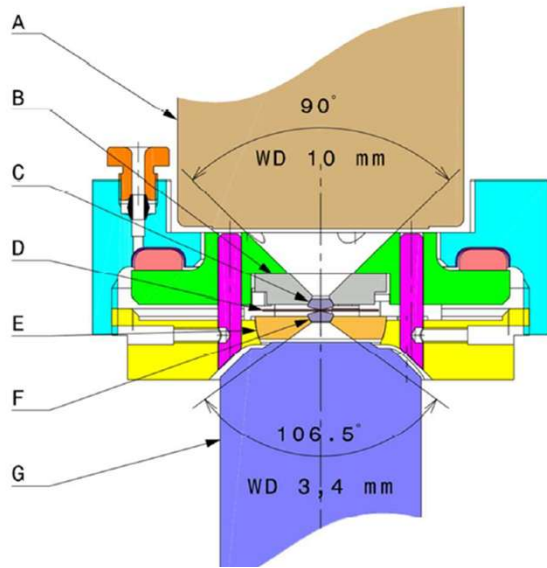

Diamond

2014

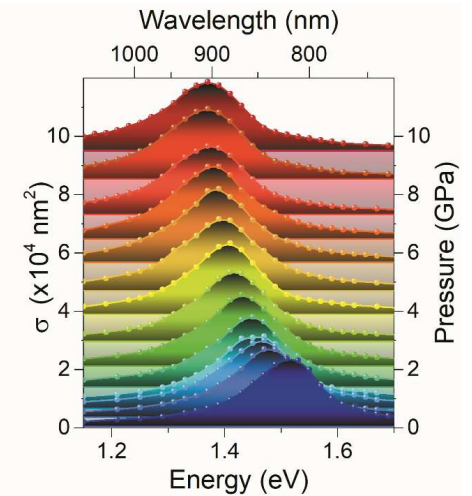
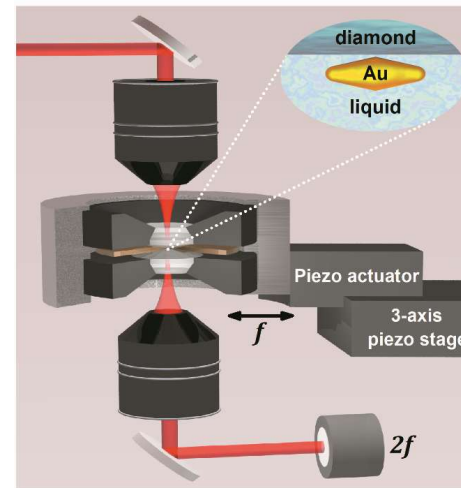
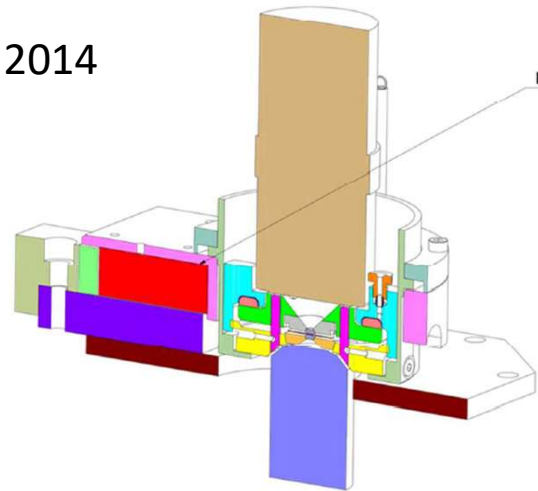

High-pressure Effect on the Optical Extinction  
of a Single Gold Nanoparticle

2018

Fabio Medeghini, Mike Hettich, Romain Rouxel, Silvio D. Silva Santos, Sylvain Hermelin, Etienne Pertreux, Abraao Torres Dias, Franck Legrand, Paolo Maioli, Aurélien Crut, Fabrice Vallée, Alfonso San Miguel and Natalia Del Fatti\*

Université de Lyon, CNRS, Université Claude Bernard Lyon 1, Institut Lumière Matière, 69622 Villeurbanne cedex, France

# High-pressure diamond anvil cell - piezo vibrator under transmission microscope

Key to the drawing :  
 (D) : diamond  
 (G) : gasket  
 (L) : light path

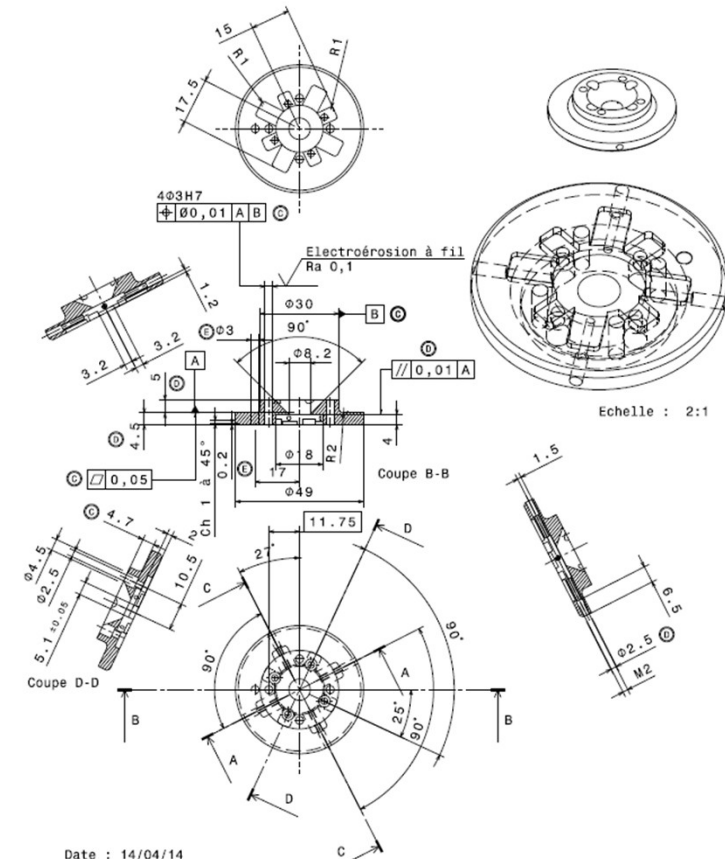
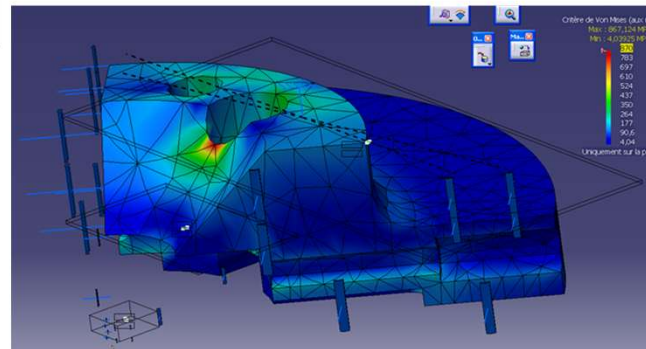
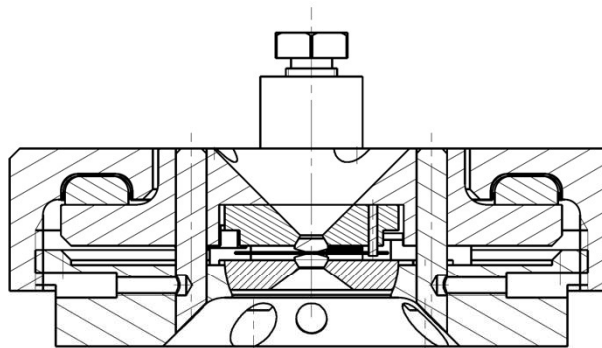
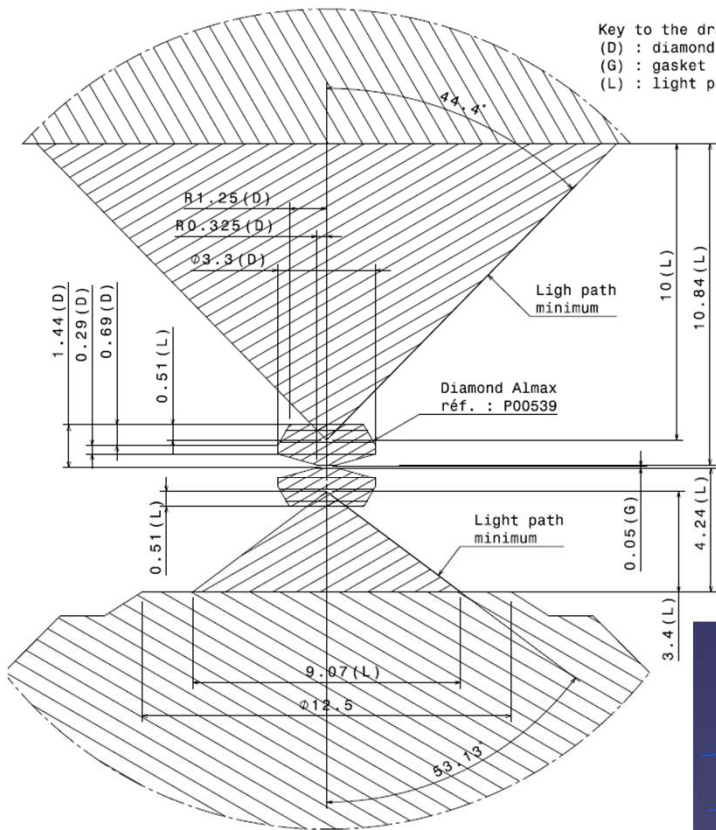

Date : 14/04/14  
 Echelle : 1/1 au format A3  
 N° de plan : 04 11 034 E  
 Tolérances générales ISO 2768 - fH  
 Matière : Acier inoxydable 100 kg  
 Nom pièce : PISTON COTE X Y (CED Nano)  
 Dessiné par F. LEGRAND  
 Institut Lumière Matière ILM



**Dynamic team**

**and**

**Material team**

# Hydrodynamic bearing rotor on a 6-axis shaker

Thesis Yvon Briend  
2020

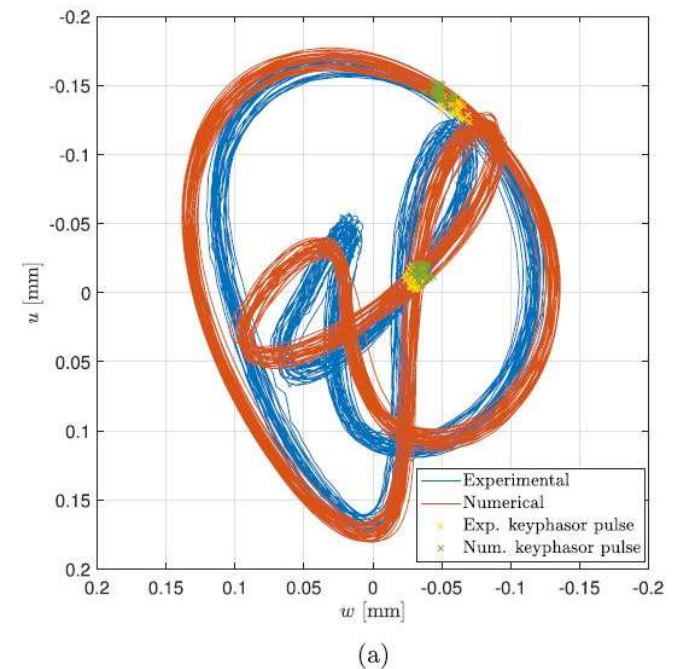
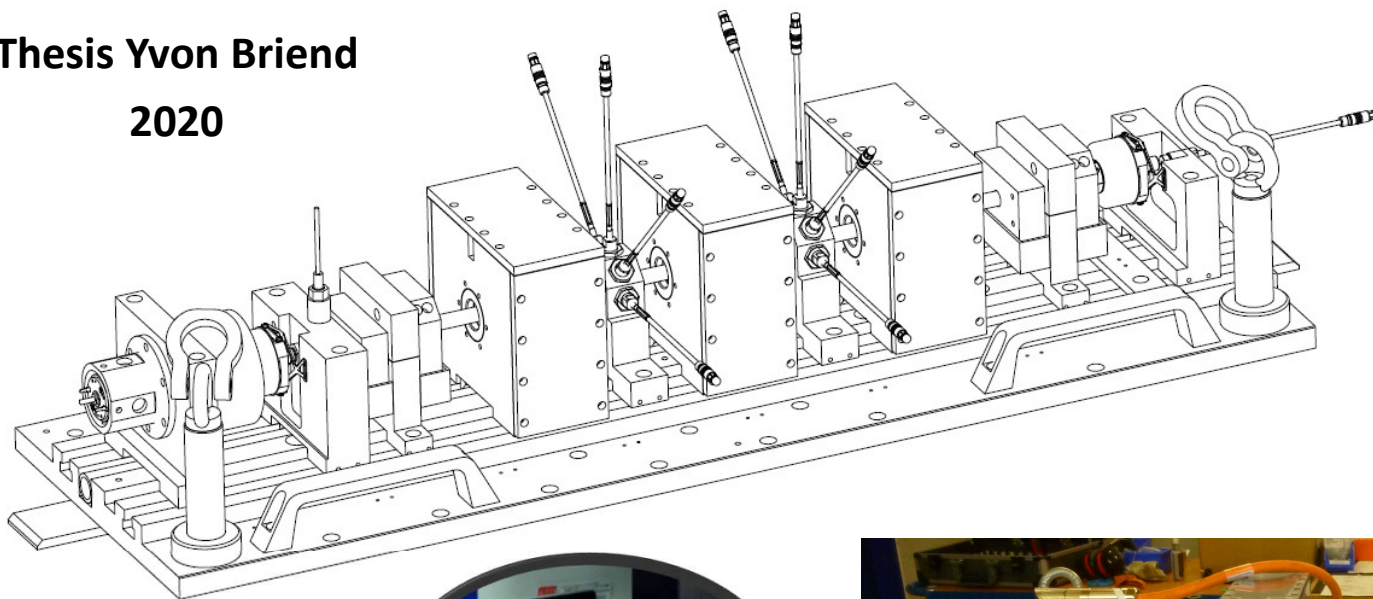
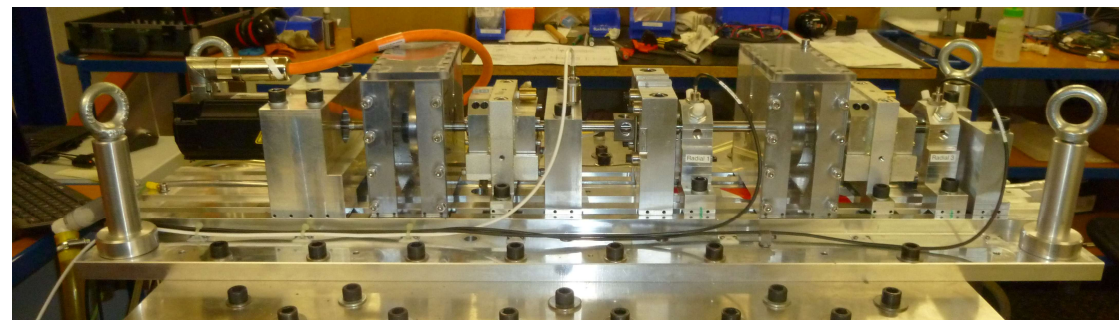
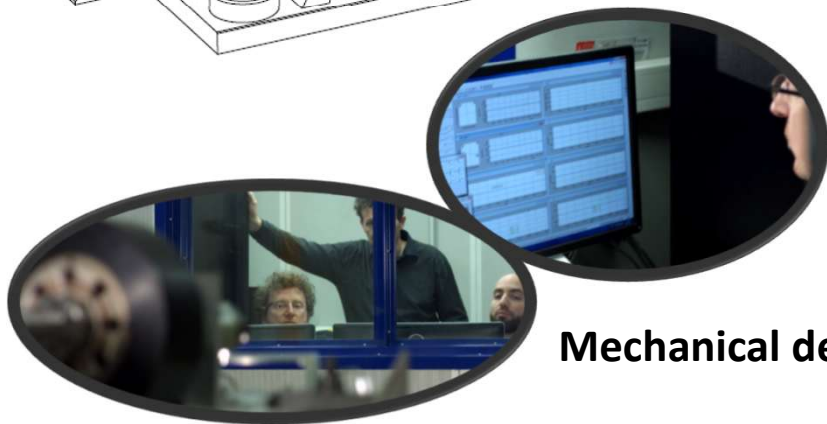
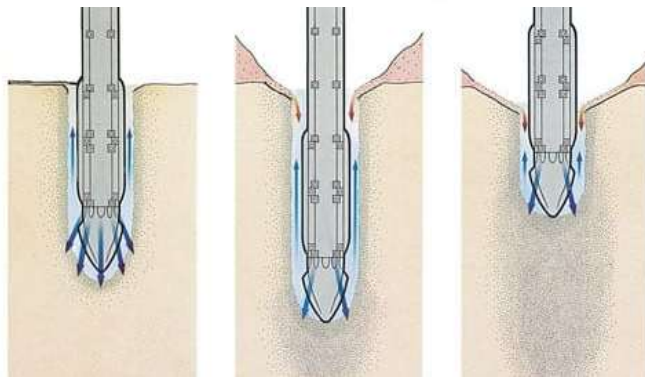
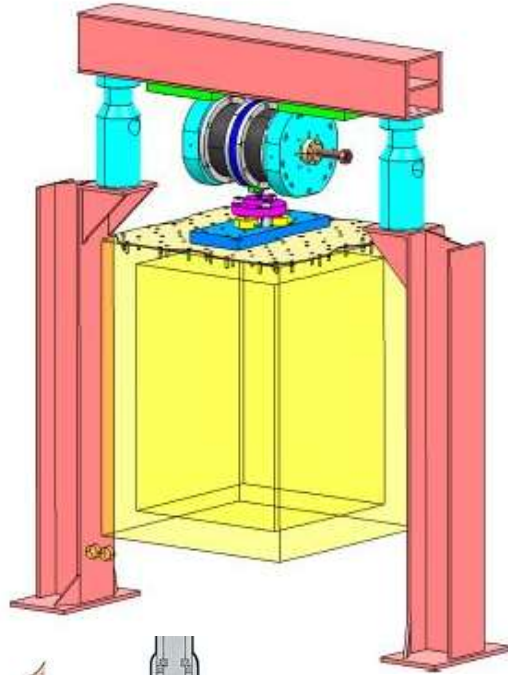
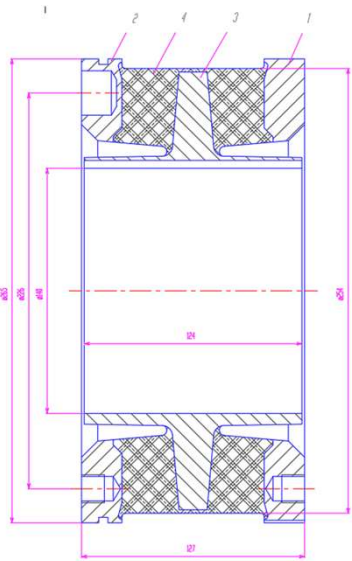

Fig. 5. Experimental-numerical comparison of shaft orbits in resp and  $\bar{Z}_0$  within a time interval of 2 s ( $\approx 57$  full shaft rotations): (a)



Mechanical design, instrumental techniques, tests engineer  
vibration and tensile testing

# Characterization of flexible elements in construction



Thesis Florian Thezenas  
2024

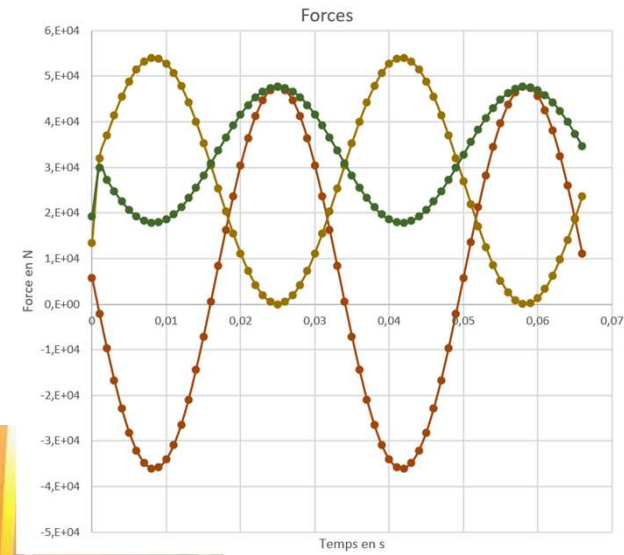

- force inertielle (avec gravité) jupe en z N FIJz FIJz=(m\*az)+(m\*g)
- force théorique en déflexion max rubber coupling en z N FRCz FRCz=-FRC\*(z/Acz)
- force totale (inertiel+ rubber C) en z N FTz FIJz+FRCz



**Mechanical design team**

# CLOUD - AM-Otech project

Anatael Cabrera – Christian Bourgeois – Arnaud Cadiou – Théo Bigourdan - Philippe Rosier

2022

the Ardennes mountains

the Meuse river

neutrino emission:  $\sim 10^{21}$   $\nu$ /s per core

**CLOUD** Detector

- **Liquido** technology
- Mass:  $\sim 5-10$  (!!!) ton
- Overburden:  $\leq 3$  m
- Baseline:  $\leq 30$  m (**UND**)
- Rate:  $\geq 10,000$   $\nu$  per day
- $\Rightarrow \delta[\phi_{\text{reactor}}] \leq 1\%$  each day — world's best precision [DC]

**Chooz-B: Reactor Cores**

## CLOUD experimental setup...

**CLOUD = "Chooz Liquido Ultraneur Detector"**

2

Anatael Cabrera (CNRS-IN2P3) — IJCLab / Université Paris-Saclay (Orsay)

# CLOUD - AM-Otech project

Anatael Cabrera – Christian Bourgeois – Arnaud Cadiou – Théo Bigourdan - Philippe Rosier

2022

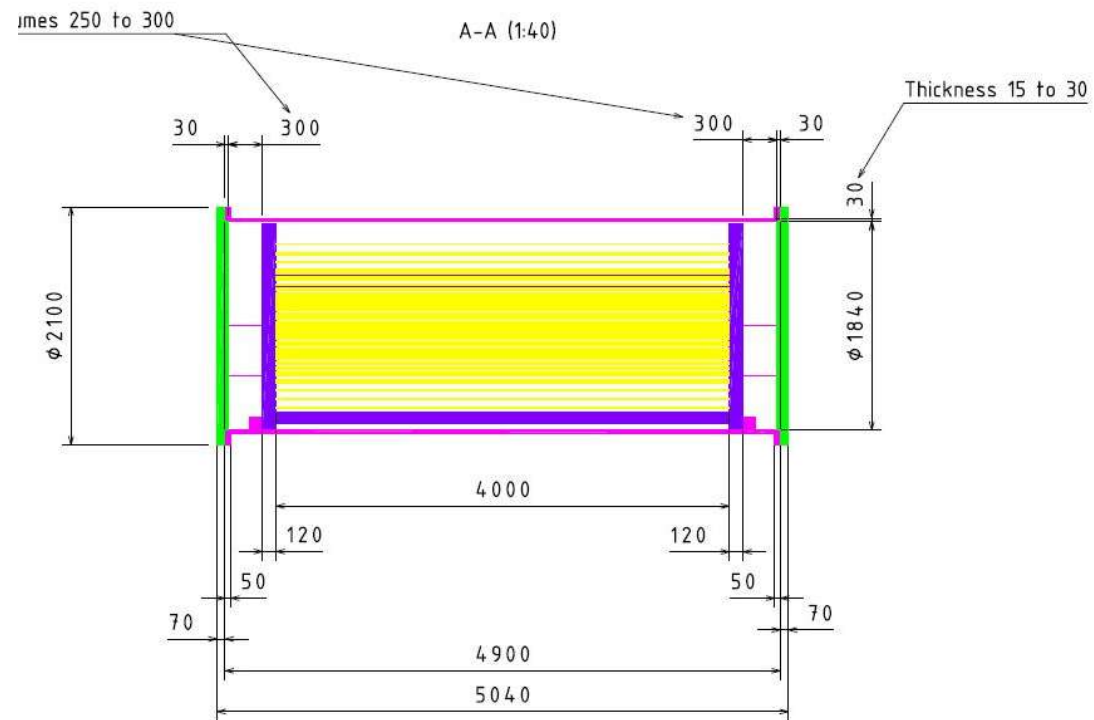
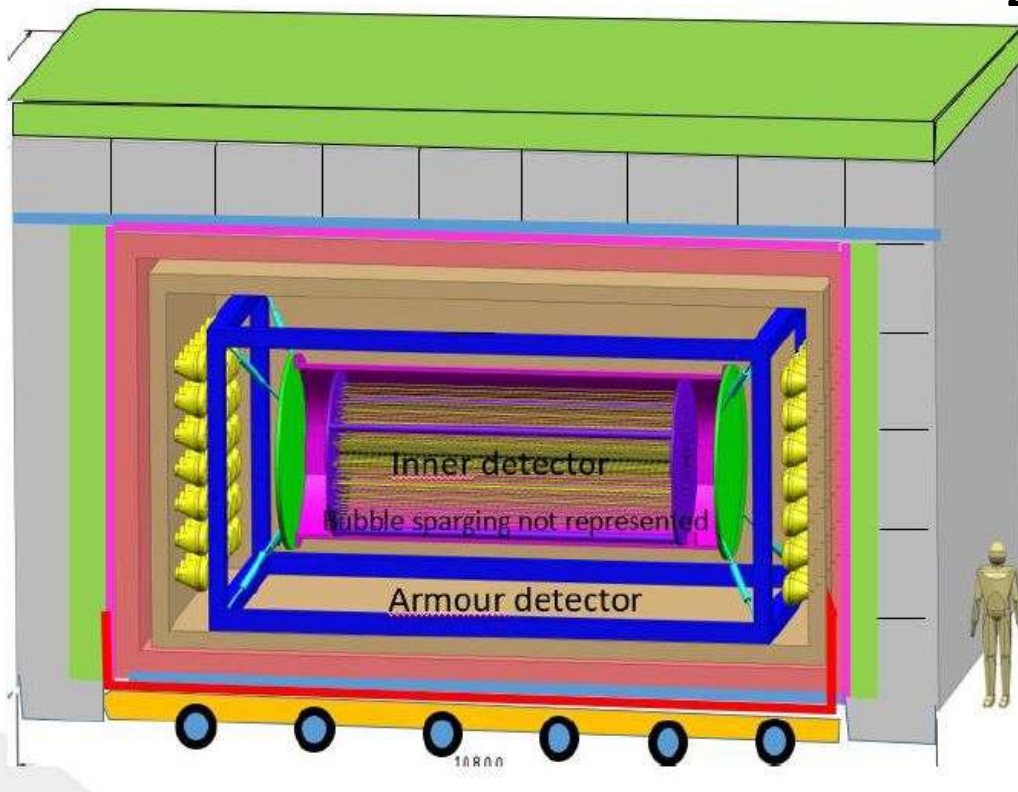

# Nitrogen cryostat V2 – MYRRHA project

Nicolas Gandolfo

Platform Manager SUPRAtech

2024

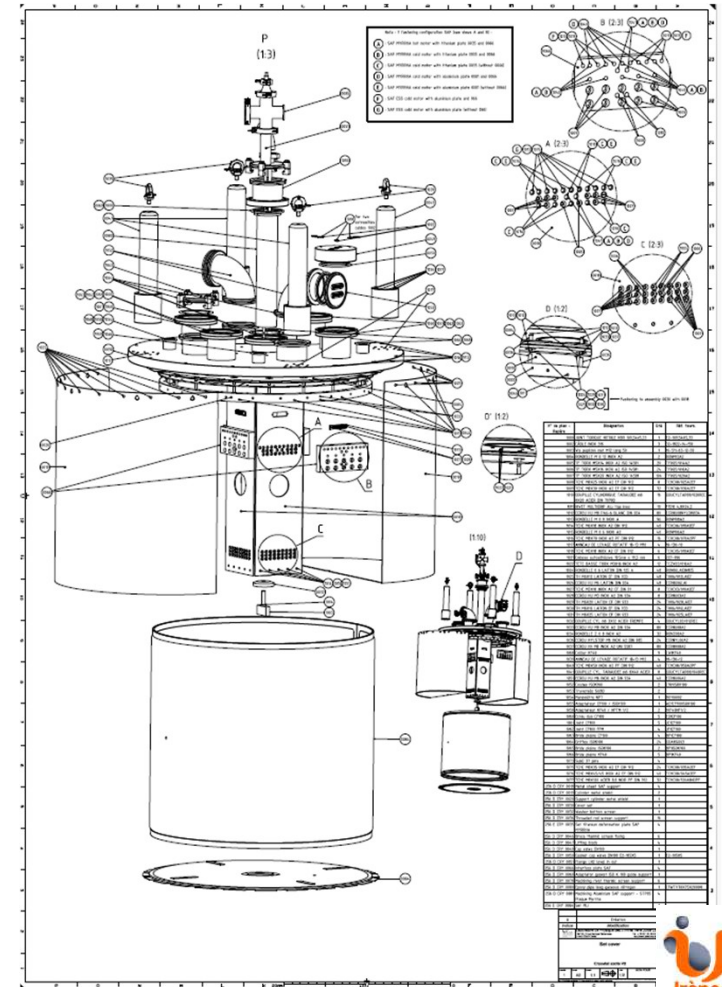
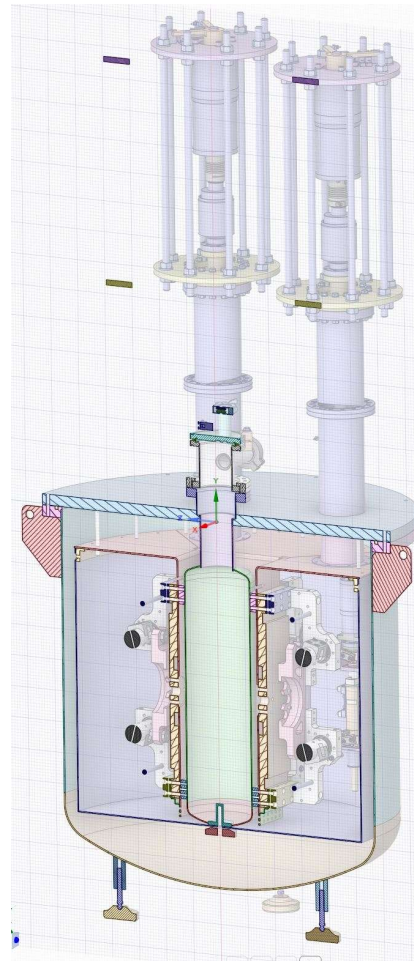
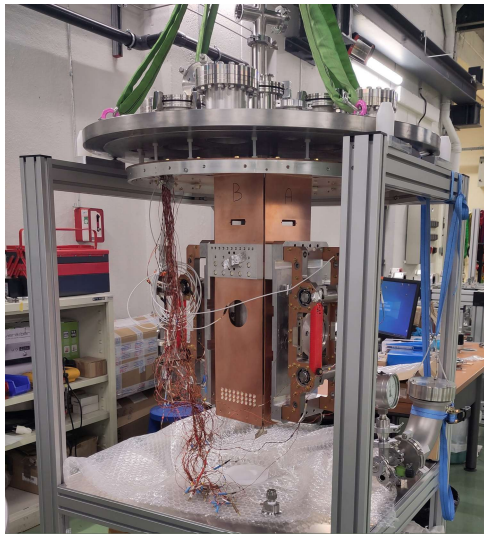

sck cen

# APC

## Initial activities in mechanical design team

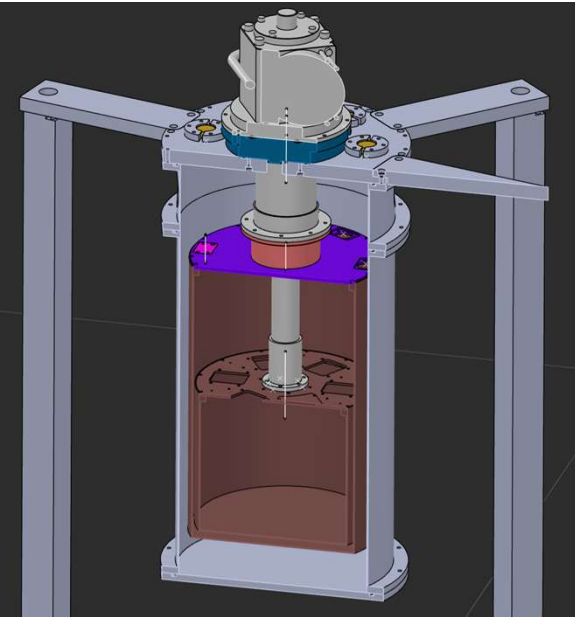

CRYOMat  
NGCRYO

**Gwendal D.**

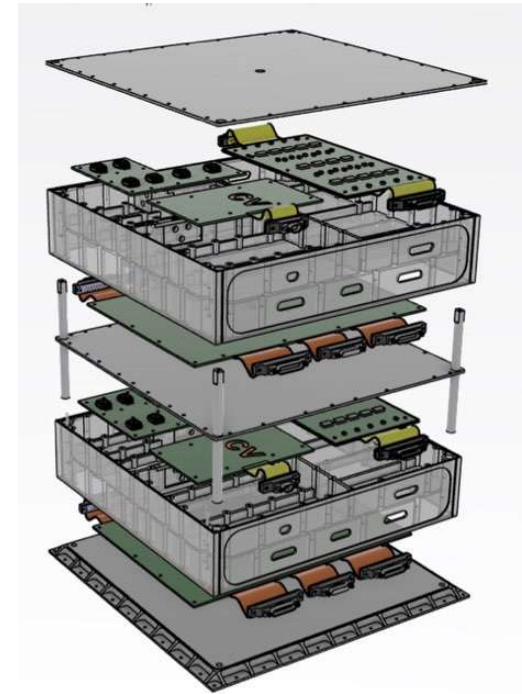

ATHENA  
X-IFU

WFEE box

Cryostat  
Frigo 1K  
continu

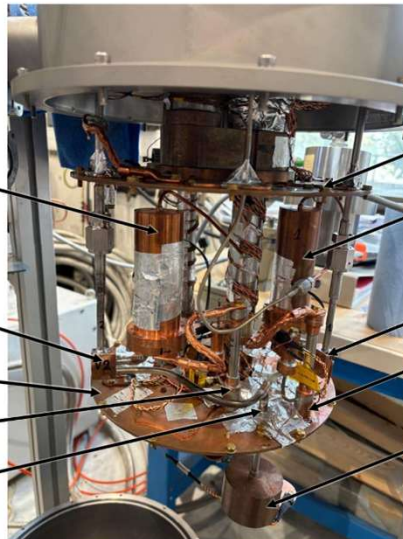

Cryopompe Frigo 1K n°2

Vanne cryogénique n°2

Étage 4K

Interrupteur thermique conductif n°2

Condenseur Frigo 1K

Étage 40K

Cryopompe Frigo 1K n°1

Vanne cryogénique n°1

Interrupteur thermique conductif n°1

Évaporateur Frigo 1K



Demonstrator  
Model 2023



Thanks

Do you have any questions?





Shape 1 all modules with different colors

# EIC – Detector Roman Pots

Raphaël Dupré – Christine Le Galliard

2026

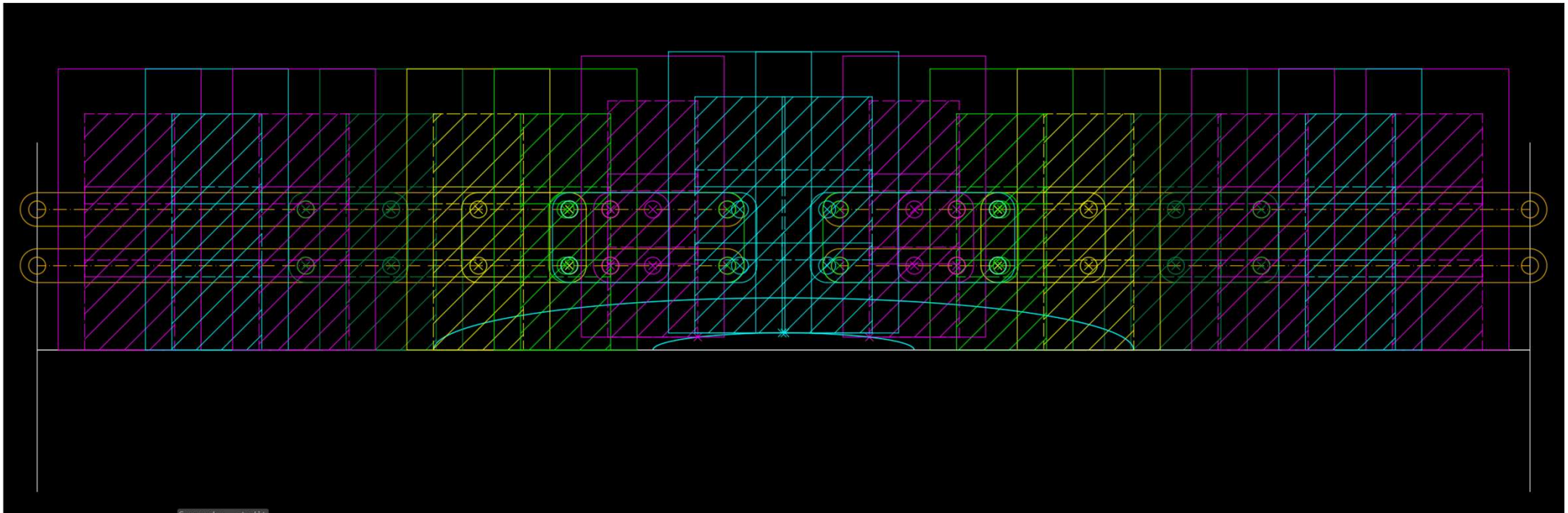



Shape 2 all modules with different colors

# EIC – Detector Roman Pots

Raphaël Dupré – Christine Le Galliard

2026

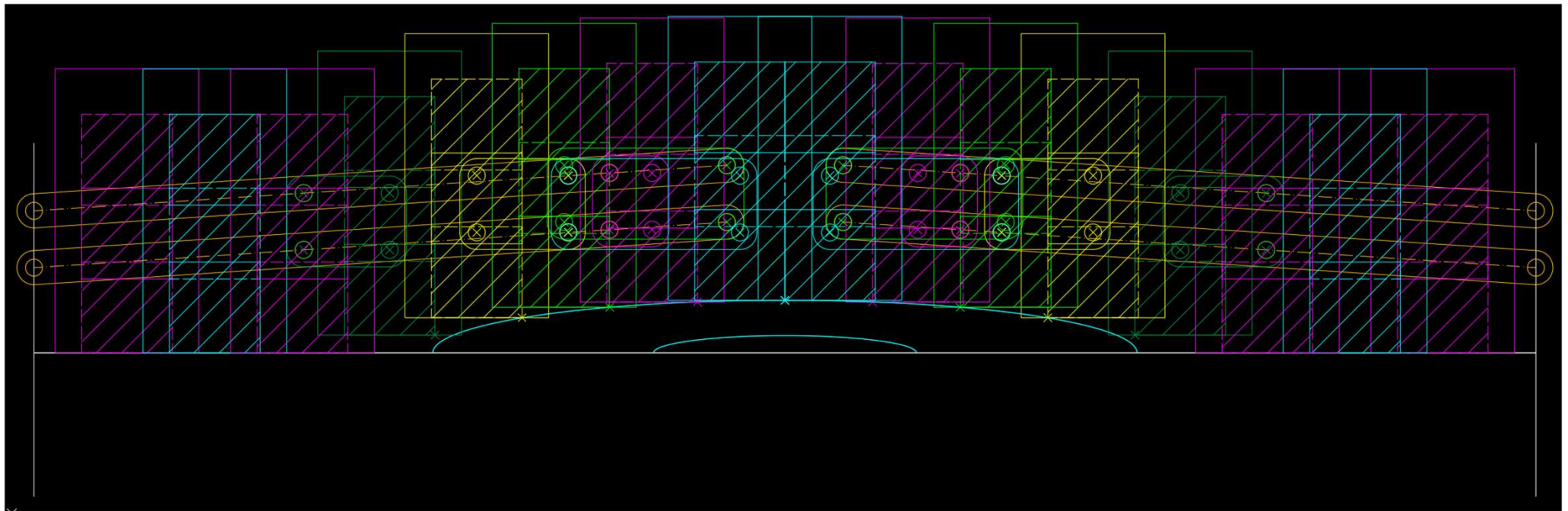

# 5. Conclusion | Résumé

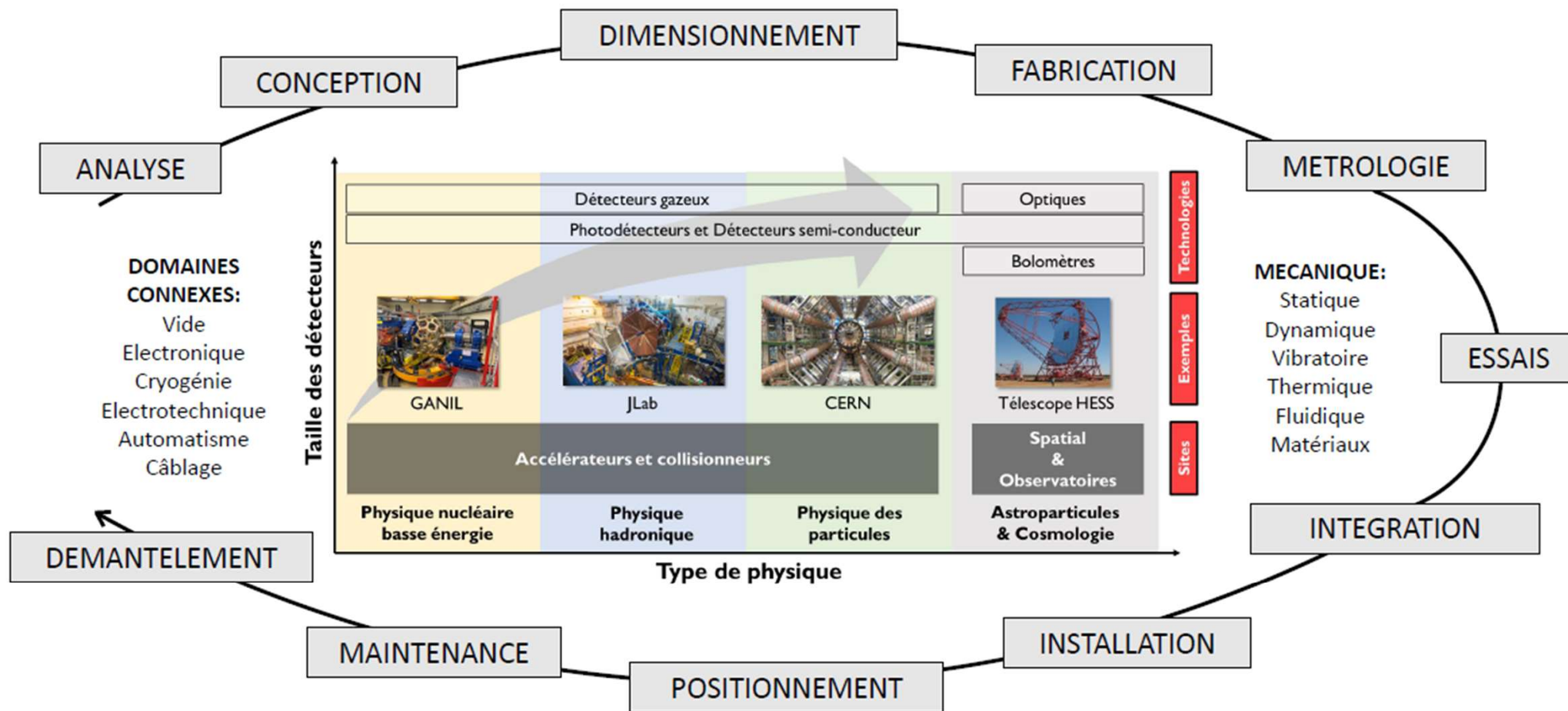



## INNER – Variations de longueur

- Déformations biscuits, liées à l'usinage, l'immersion dans le temps dans le liquide
- Intervalles de tolérance de fabrication (la coupe à longueur de la fibres, le système piston, les colonnes, les épaisseurs de biscuit, le système de reprise d'effort fixé au biscuit)
- Fluage

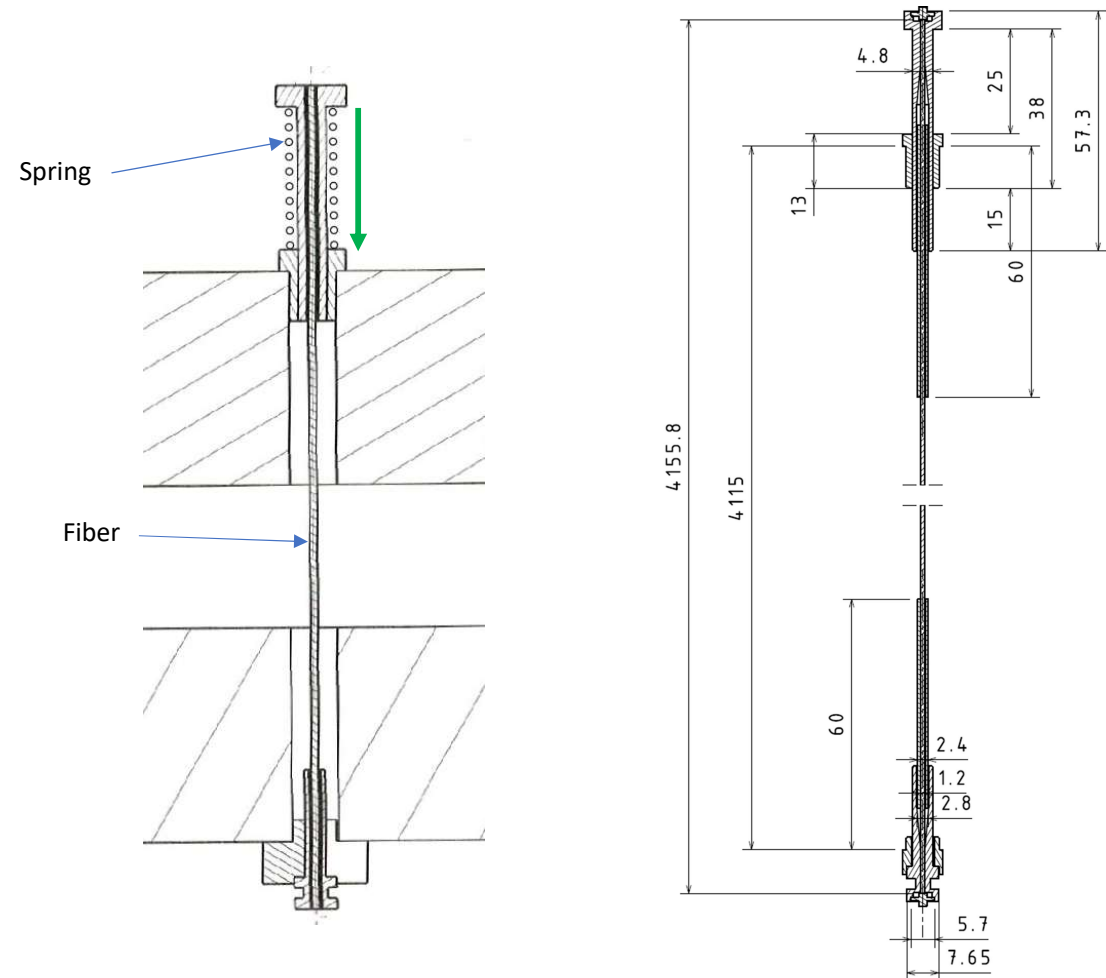



# INNER – Sag fibers – LiquidO effect : analytic calculation with « la Chainette »

Densité LiquidO	0,9
Densité fibre (PS)	1,06

Gravité – poussée d'Archimède

Poids minoré dans les calculs = **15,1% de la gravité** =  $1 - (0,9 / 1,06)$

## Le poids $\vec{P}$

- ▶ Force verticale
- ▶  $\vec{P} = -P\vec{j} = -\mu \cdot dl \cdot g \cdot \vec{j}$
- ▶  $\mu$  est la masse linéique
- ▶ masse de notre petit bout est  $\mu \cdot dl$
- ▶  $g \approx 9,81 \text{ m/s}^2$

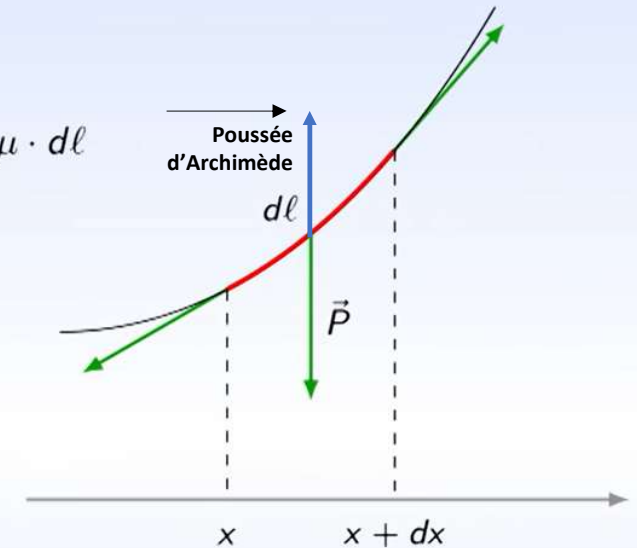

Découpage infinitésimal de la chaînette

1 / 10

Flèche en fonction de la force dans l'air  
Fibre Ø1 longueur 4 m à l'horizontale

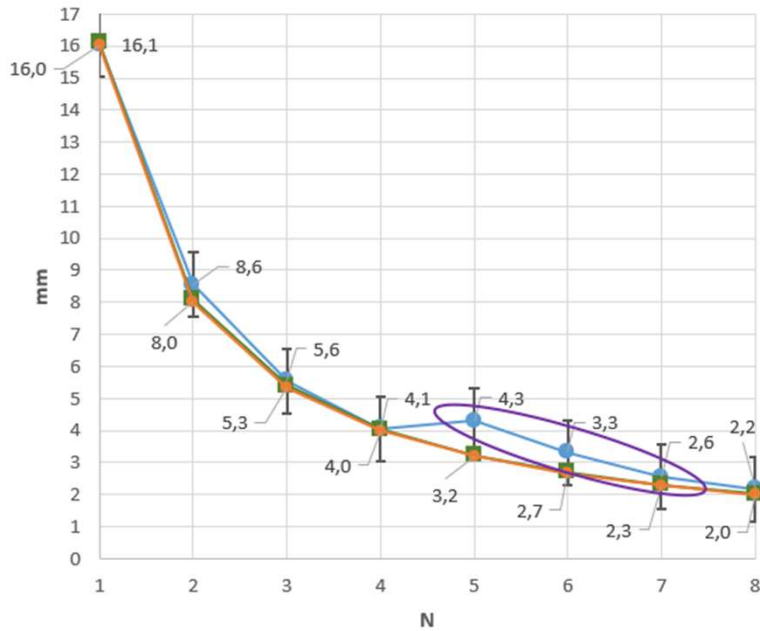

● Essais   
 ■ Calculs EF (Philippe R.)   
 ▲ Calculs analytiques Chainette (Arnaud C.)



Flèche en fonction de la force dans le liquidO  
Fibre Ø1 longueur 4 m à l'horizontale

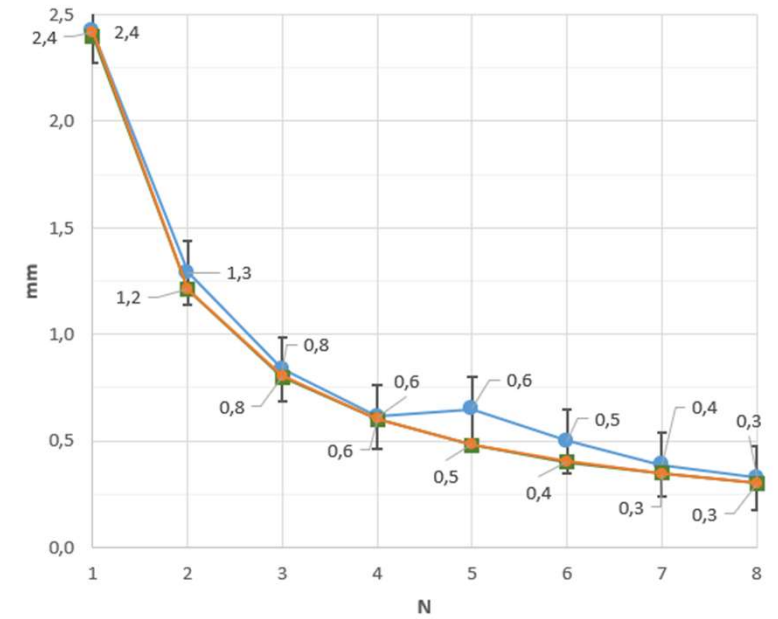

● Essais avec poids minoré   
 ■ Calculs EF (Philippe R.)   
 ▲ Calculs analytiques (Arnaud C.)