

# Neutrino Physics at the SHiP experiment

Antonio Iuliano<sup>1</sup>, on behalf of the SHiP Collaboration

<sup>1</sup>Università di Napoli and INFN



# The Standard Model and Beyond

- **The Standard Model:** Complete, renormalisable theory and fully consistent with all experimental data so far
- With some unanswered questions....
  - ...Gauge hierarchy?
  - ...Baryogenesis and CP violation?
  - ...Dark Matter and Dark Energy?
- The hunt for new Physics is continuously on!

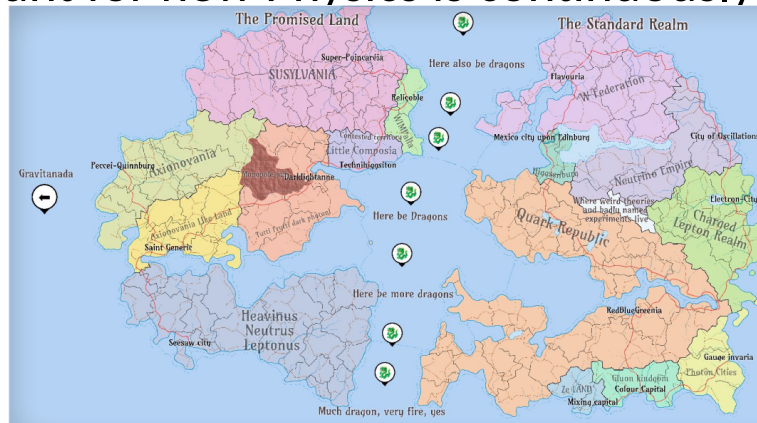

M.Climescu,  
Blois 2026

# Frontiers towards new Physics

- Looking for particles not reachable by current detectors
- Exploring signals from
  - ....heavy particles: high energy colliders
  - ....weaky interacting particles: **high intensity**

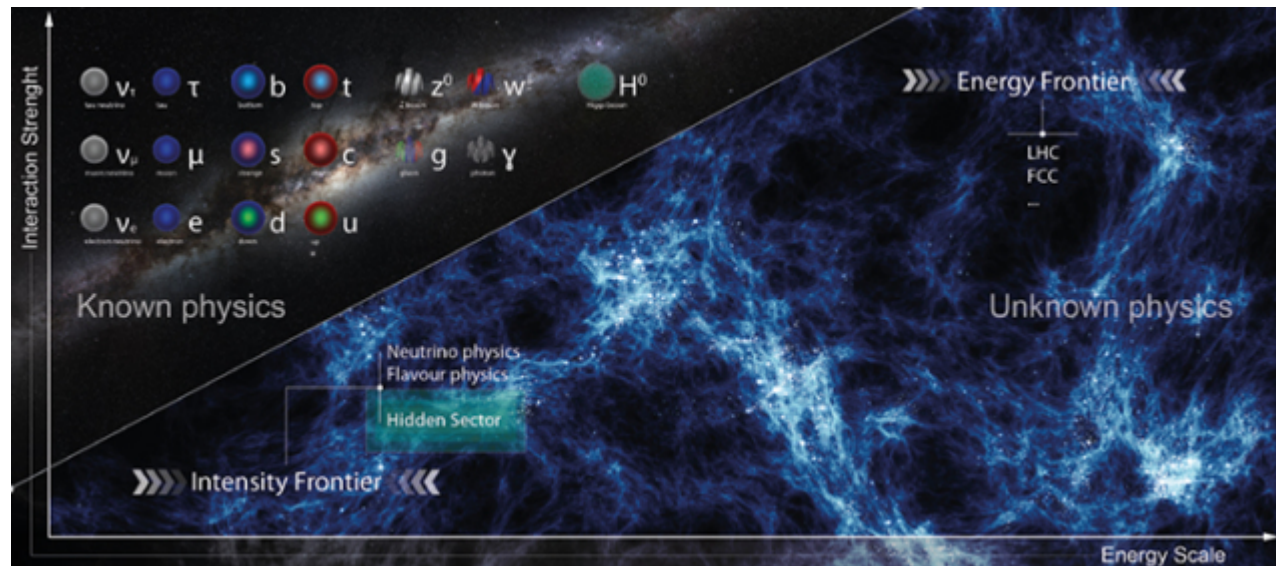

# SHiP@The Beam Dump Facility

- 400 GeV/c protons from the **CERN SPS** accelerator
- Dedicated beamline towards ECN3
- **$10^6$  spills of 1 s duration, each  $4 \times 10^{13}$  p.o.t., per year**

**CERN COURIER** Reporting on international high-energy physics

Physics ▾ Technology ▾ Community ▾ In focus Magazine

SEARCHES FOR NEW PHYSICS | NEWS  
**SHiP to chart hidden sector**  
3 May 2024

**Full speed ahead** Layout of the SHiP experiment, with the target on the left and the experiment in the ECN3 hall. Credit: SHiP collab.

In March, CERN selected a new experiment called SHiP to search for hidden particles using high-intensity proton beams from the SPS. First proposed in 2013, SHiP is scheduled to operate in the North Area's ECN3 hall from 2031, where it will enable searches for new physics at the "coupling frontier" complementary to those at high-energy and precision-flavour experiments.

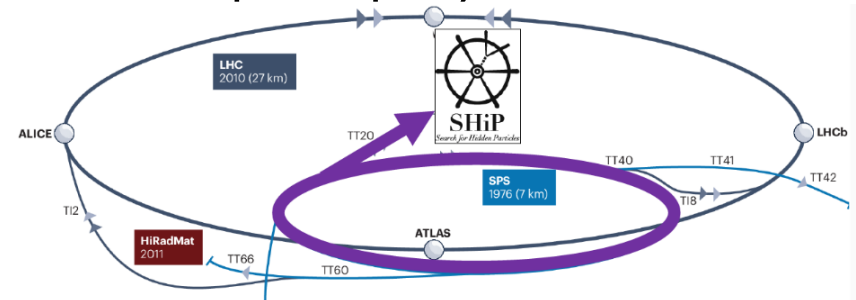

• Ideal facility for a fixed target experiment in the intensity frontier -> the SHiP experiment

• **Approved** by CERN Research Board in March 2024



# The SHiP experiment

- Experimental design main components
  - Proton Target
  - Muon Shield
  - Scattering and Neutrino Detector
  - Decay Vessel
  - Hidden Sector Detector

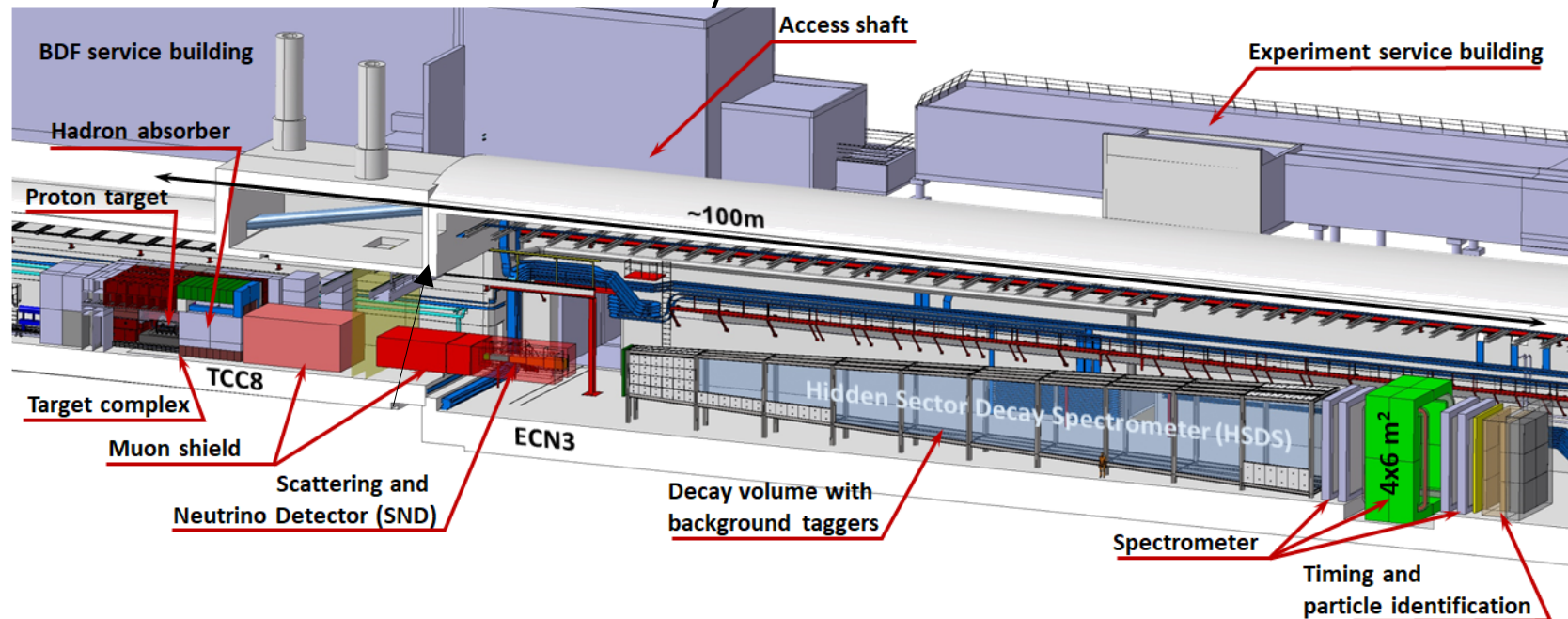

# The proton target

- Pure tungsten as passive material
- Produce also hadrons with charm and beauty quarks → explore  $O(\text{GeV})$  mass region
- Hadron stopper: absorb pions and kaons before their decay

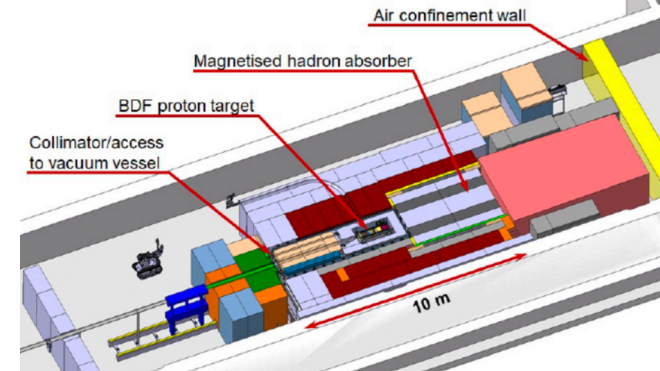
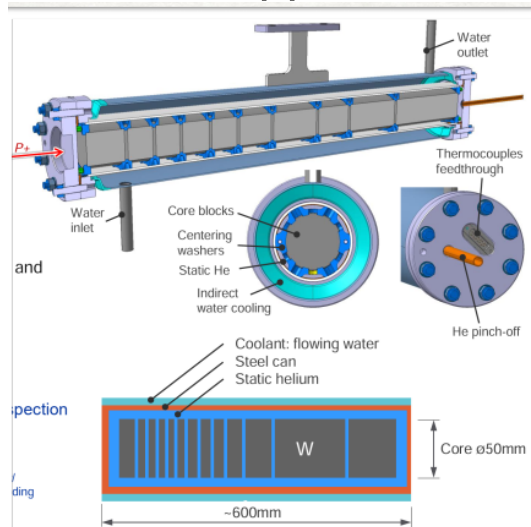

# Muon Magnetic Shield

- From each spill,  $O(10^{11})$  muons produced, background for SHiP
- Need to suppress them  $\rightarrow$  sweep them away with a set of magnets
- Different magnets and polarities to cover all angles and energies
- Modular design, multiple versions and performance comparisons

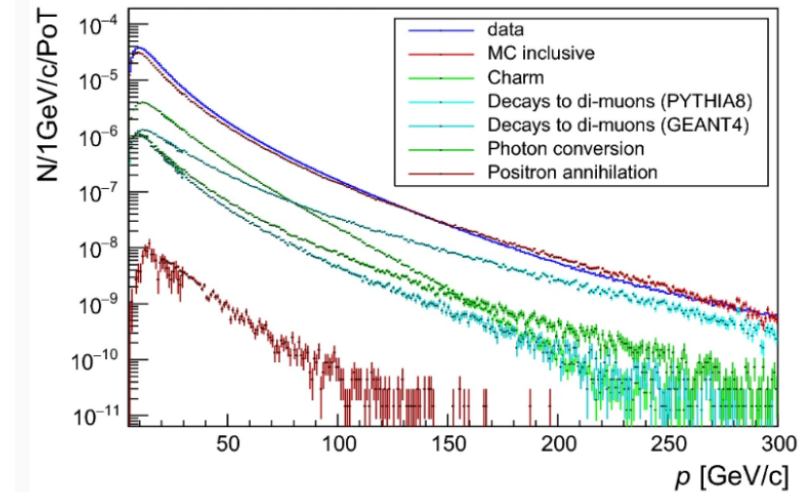
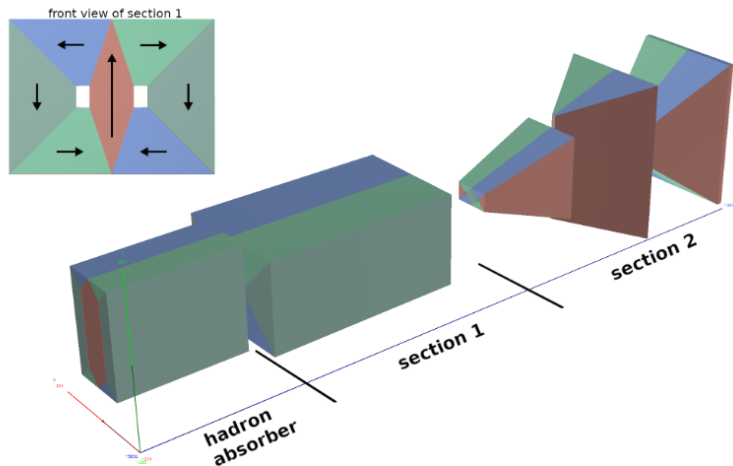

# Muon flux measurement

- Data taken in 2018 with a SHiP target replica followed by a magnetic spectrometer
- Measured muon flux
- Validation of momentum distribution from Monte Carlo simulations

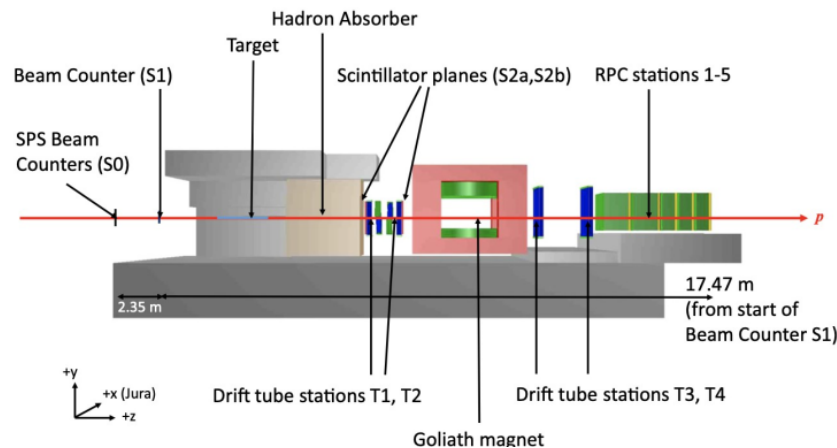

EPJ C80 (2020) 84

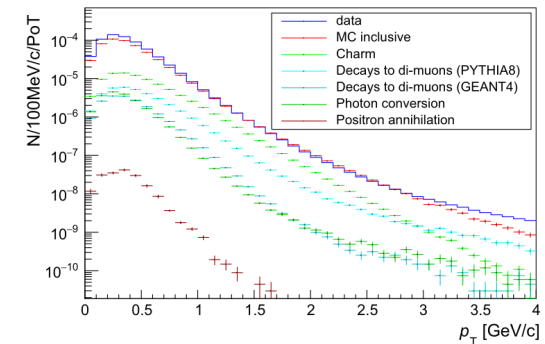
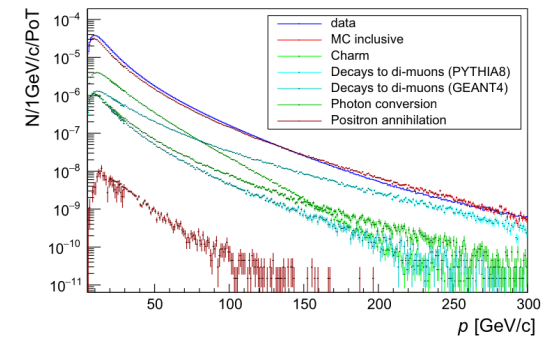

# Muon Magnetic Shield - performance

- Studied with detailed MC simulation tuned with real data
- Reduction to less than  $10^5$  muons per spill, via magnetic deflection
- At the end, also suitable for the insertion of a neutrino detector
- Advanced stage of design → TDR planned in 2027

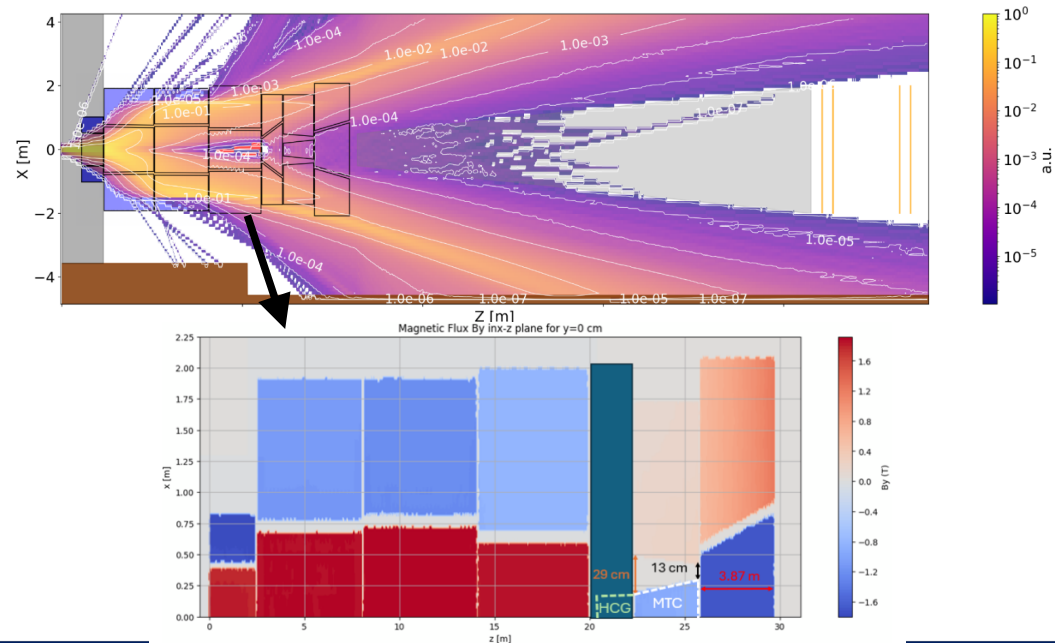

# The Hidden Sector Detector

- Decay vessel filled with He for the production of Hidden Sector particles
- Surrounding Background Tagger detecting incoming particles from outside
- Timing resolution  $\sim 1$  ns,

spatial resolution  $\sim 10$  cm

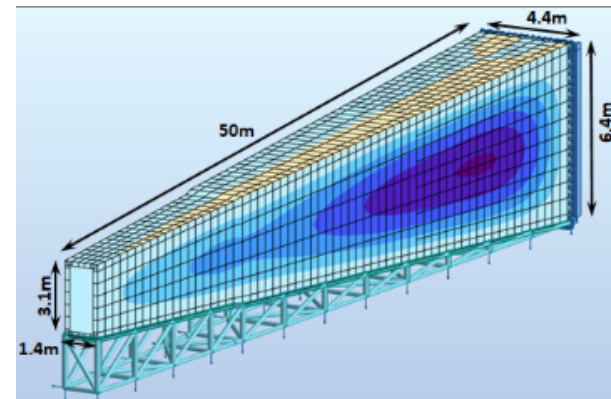
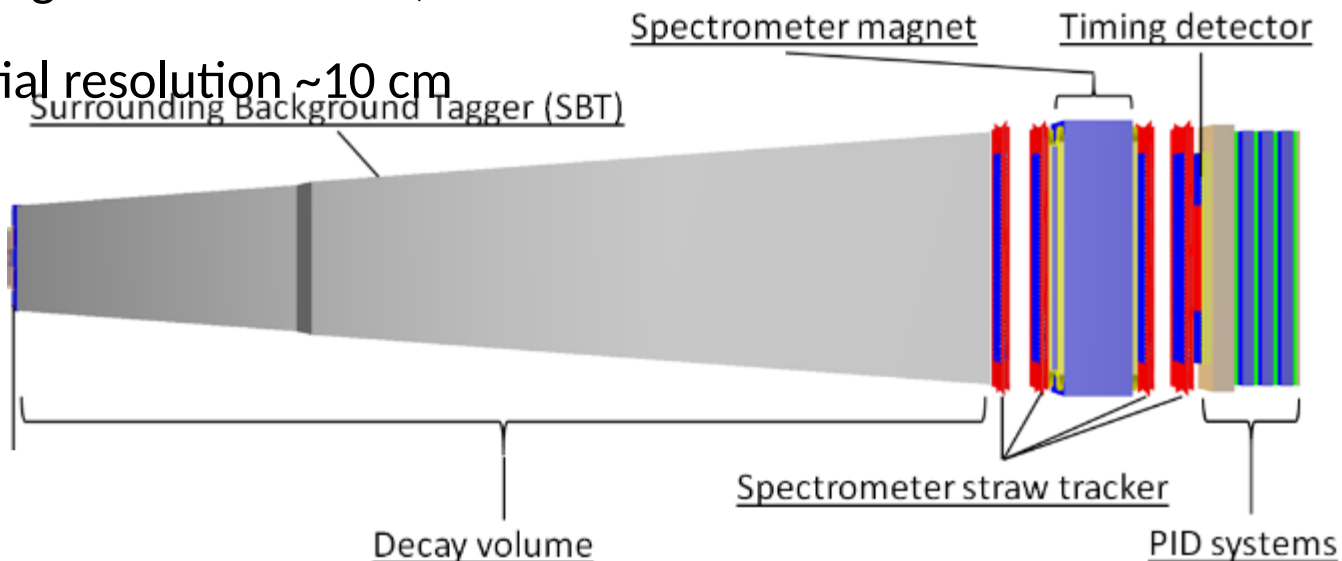

# Magnetic Spectrometer

- Within the Hidden Sector Detector
  - Magnetic Spectrometer
  - Timing Detector
  - Tracking System (Straw Tubes)
- Currently ongoing tests on prototypes

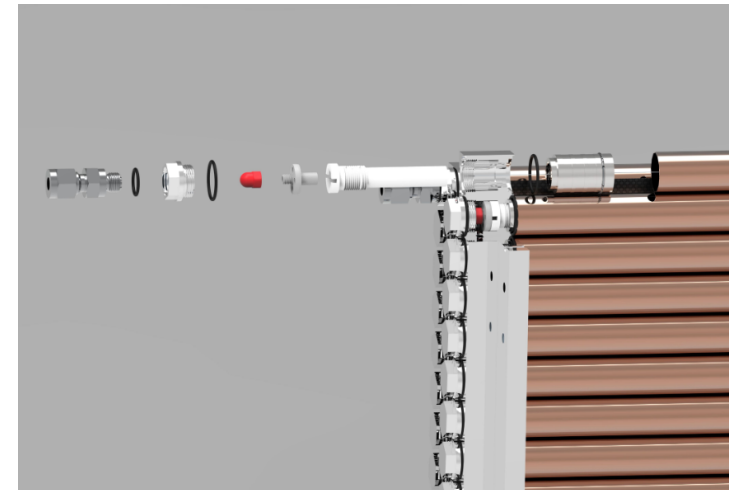
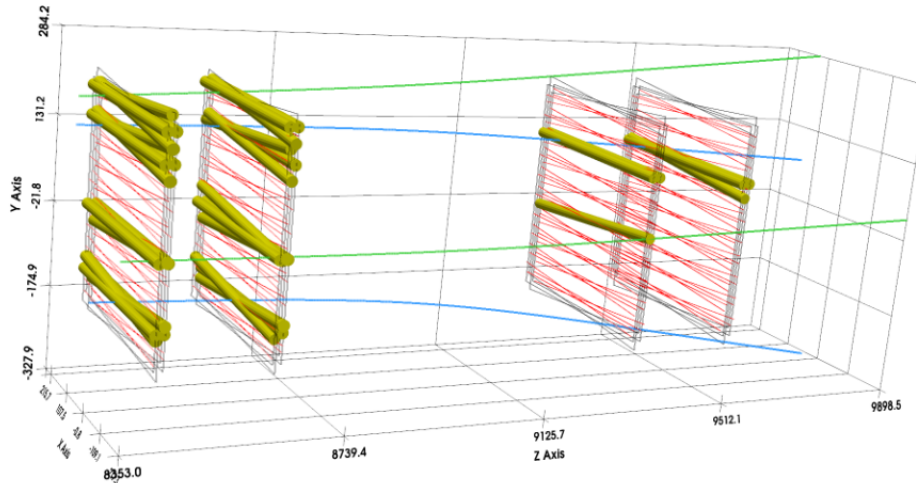
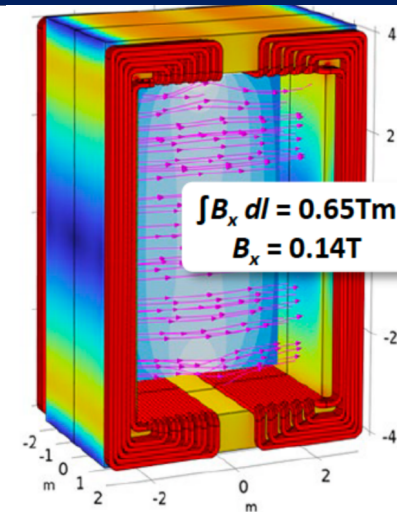

# Calorimeter System

- Electromagnetic and Hadronic calorimeter
- PID performance essential for background rejection
- SplitCal concept :
  - Scintillator bars and SiPMs → energy reconstruction
  - High Precision Layers → shower directionality

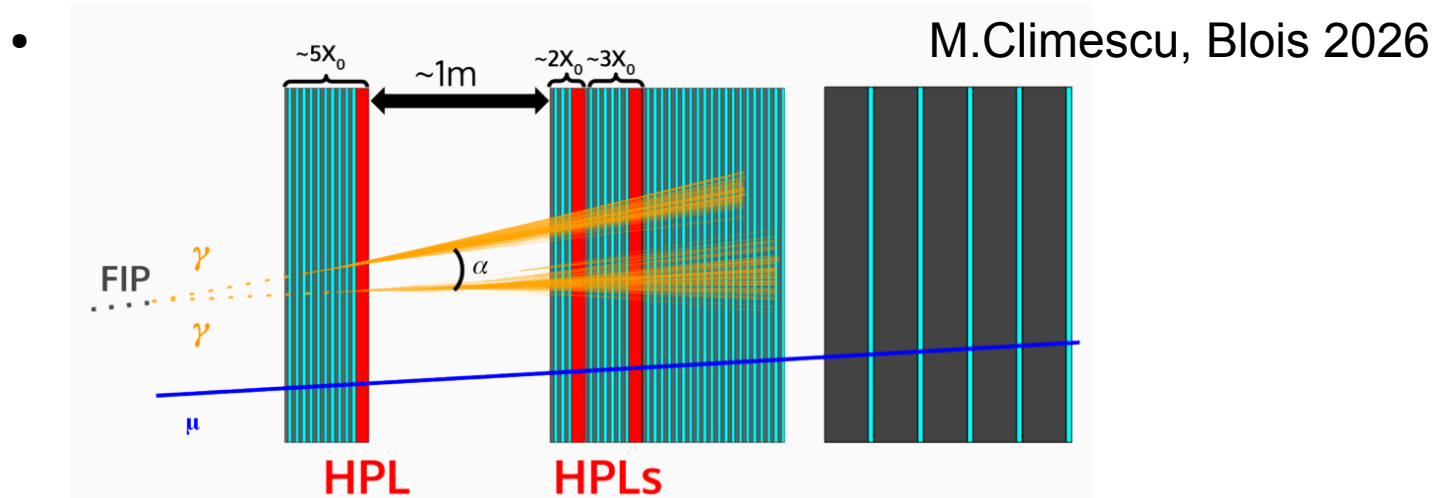

# Detection technique

- Standard Model background exclusion with a redundancy of preliminary filters and event selection criteria
- Topology: Hidden Sector Particle Decays in Standard Model Particles
- Independent from single reference theory models

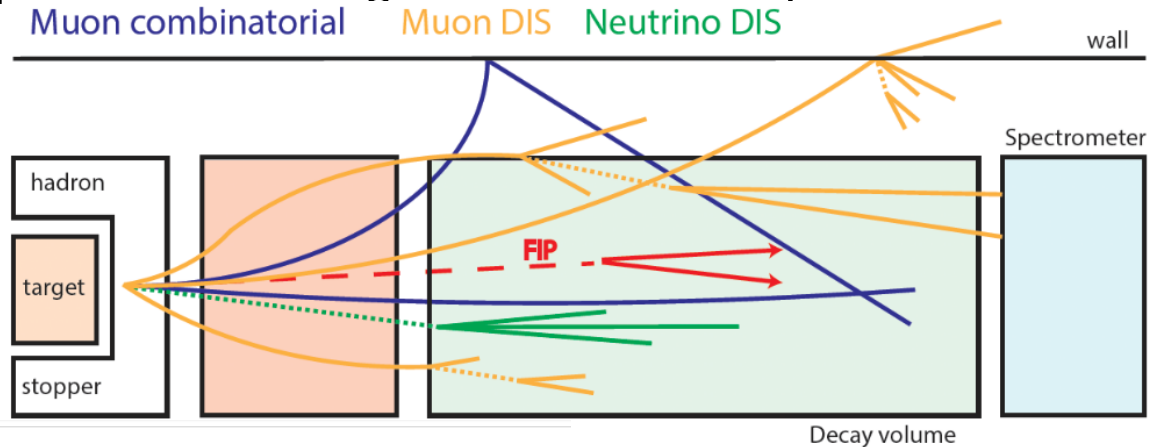

## Selection

Track momentum	$> 1.0 \text{ GeV}/c$
Track pair distance of closest approach	$< 1 \text{ cm}$
Track pair vertex position in decay volume	$> 5 \text{ cm}$ from inner wall $> 100 \text{ cm}$ from entrance (partially)
Impact parameter w.r.t. target (fully reconstructed)	$< 10 \text{ cm}$
Impact parameter w.r.t. target (partially reconstructed)	$< 250 \text{ cm}$

## Background source

Background source	Expected events
Neutrino DIS	$< 0.1$ (fully) / $< 0.3$ (partially)
Muon DIS (factorisation)	$< 5 \times 10^{-3}$ (fully) / $< 0.2$ (partially)
Muon combinatorial	$(1.3 \pm 2.1) \times 10^{-4}$

Time coincidence + UBT/SBT



# Sensibility towards new physics portals

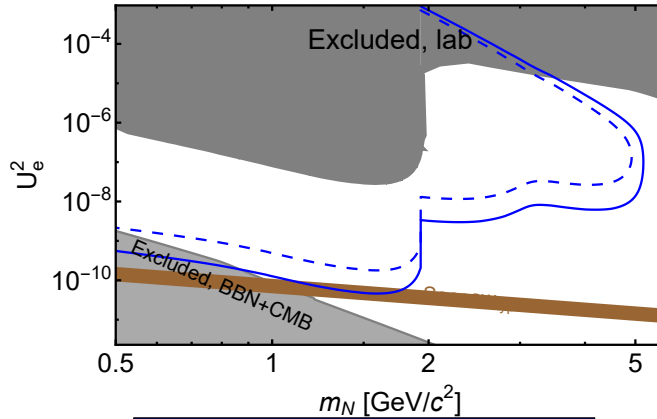

Neutrino Portal

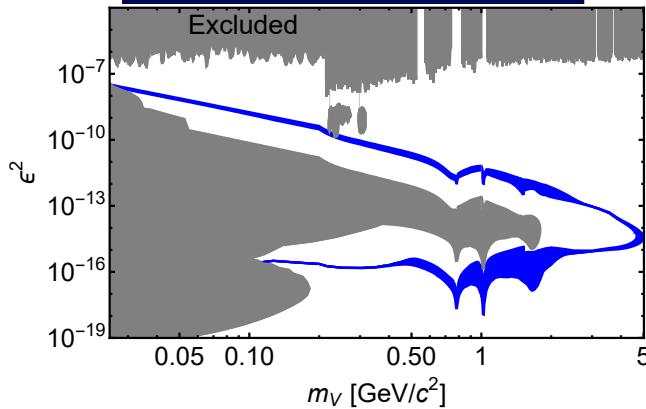

Vector Portal

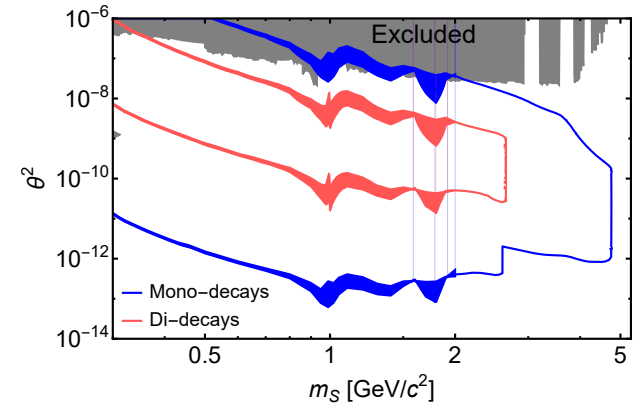

Scalar Portal

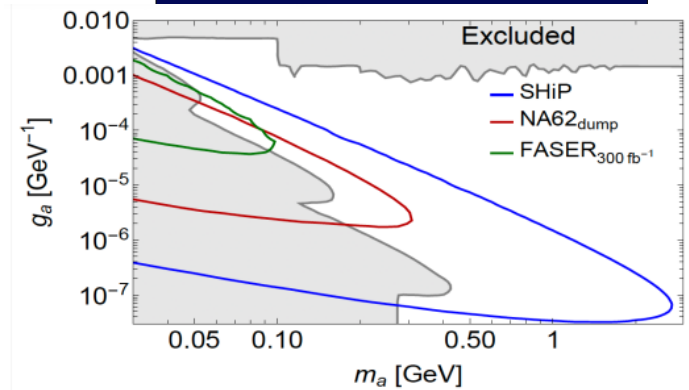

Axion Portal



# Neutrino detection in SHiP

- In the middle of the SHiP experimental layout
- High intensity beam from the SPS
- Clean environment from most Standard Model particles
- Suitable for neutrino physics studies, including tau neutrinos

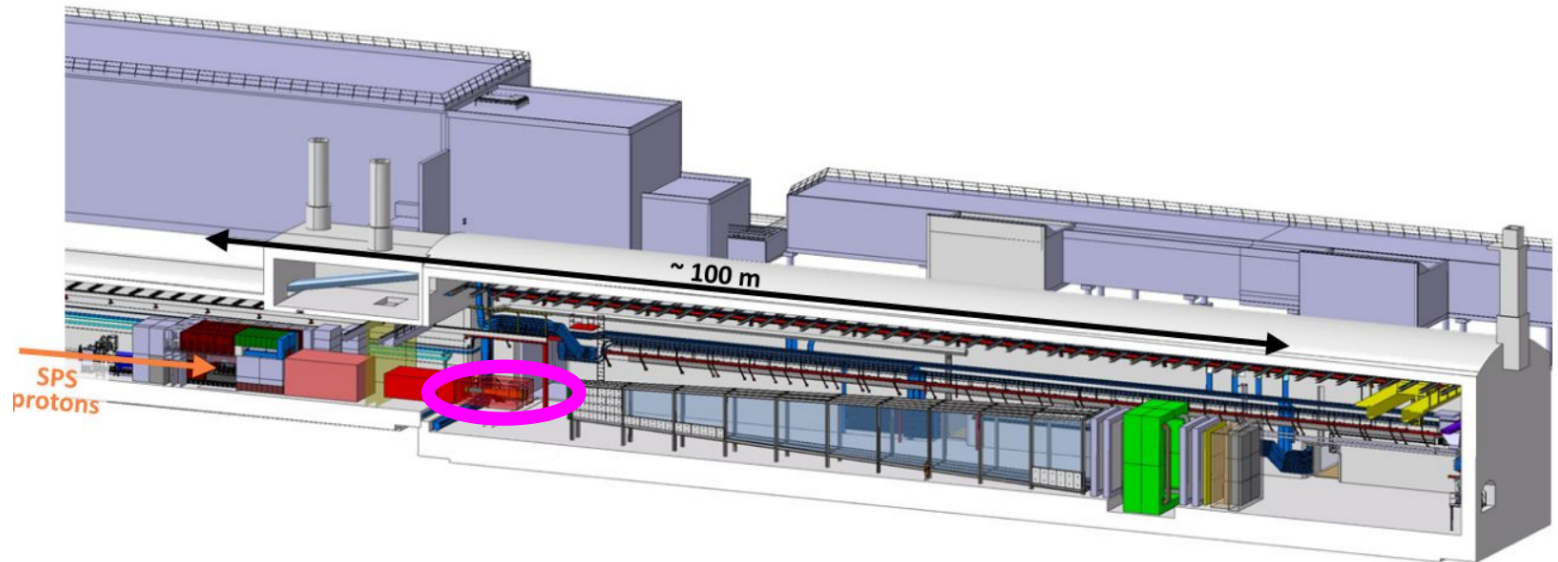

# The Scattering and Neutrino Detector

- **Upstream veto** excluding entering charged particles
- **High granularity Si/W electromagnetic calorimeter** with  $O(10\mu\text{m})$  accuracy
- **Magnetized calorimeter** measuring hadron shower energy and muon momentum

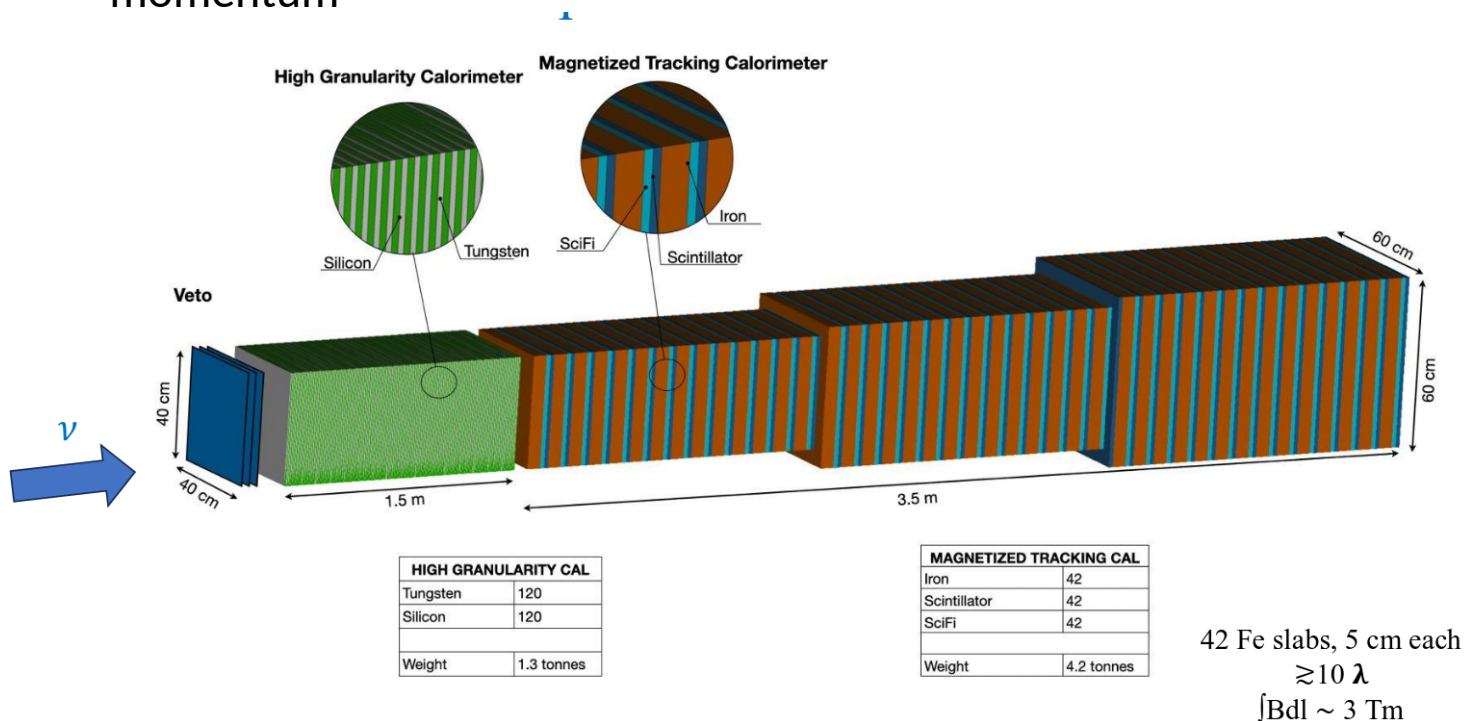

# Technologies for the SND@SHiP



SiStrip detector



SciFi detector

Other options  
under study:

- Silicon Pixel
- Nuclear emulsion film

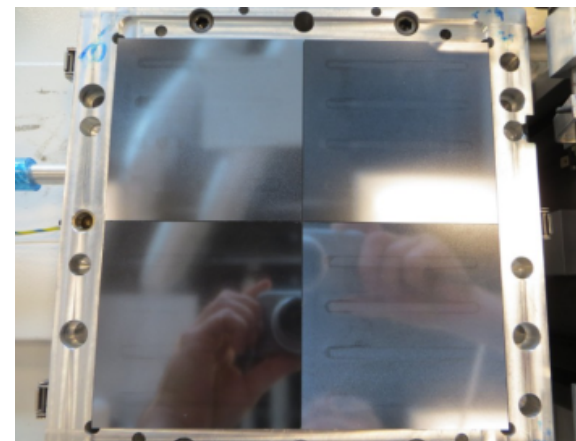

Silicon Pad

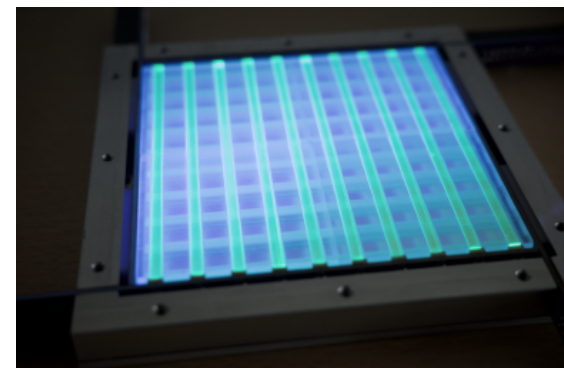

Scintillator tiles



# SND and muon shield

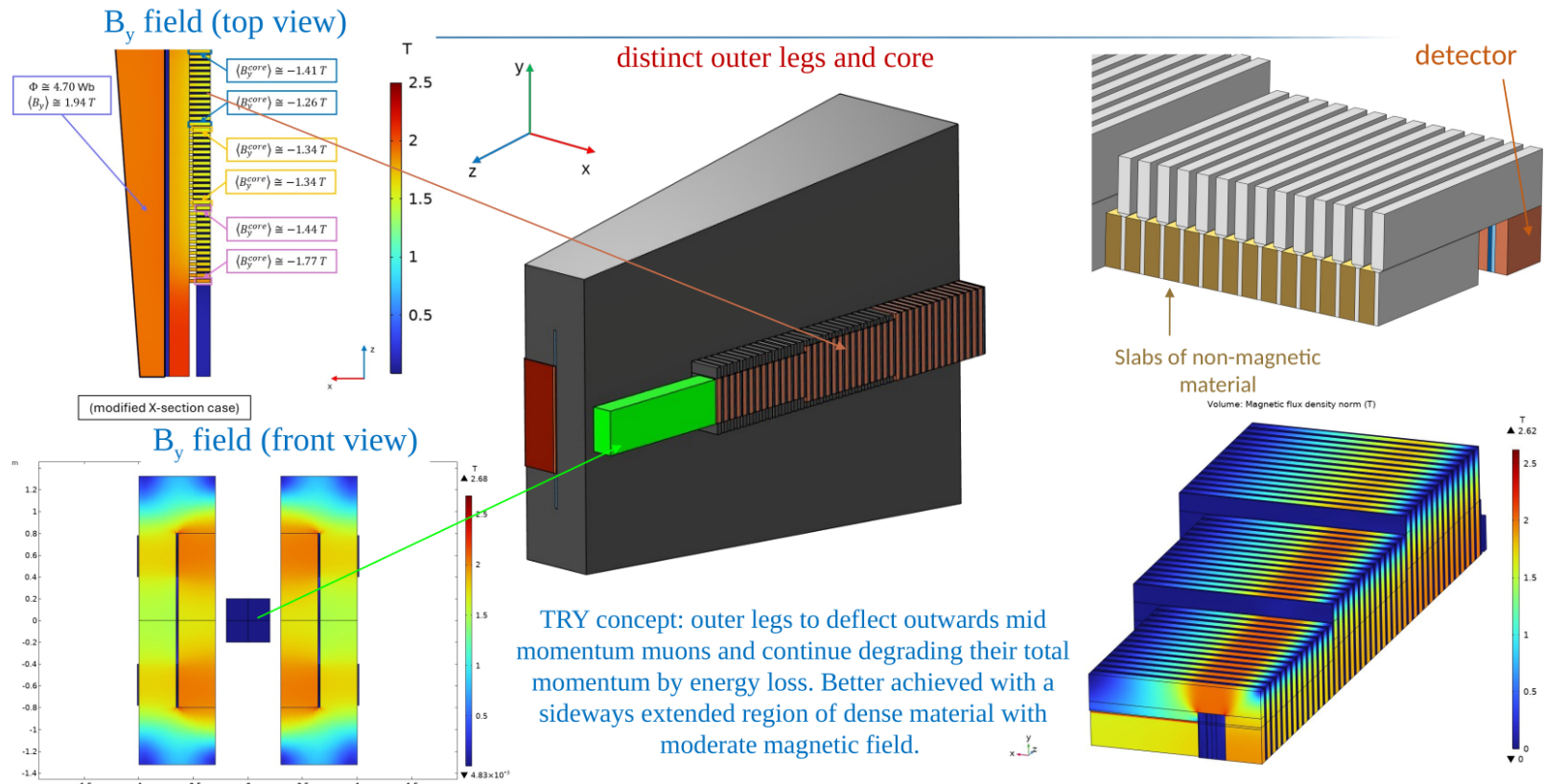

# Neutrino signal in SND

- Detect neutrinos from all flavours
- Measure hadron shower energy
- Muon charge identification in the magnetized section
  - Separation  $\nu_\mu$  and anti- $\nu_\mu$
- Separation  $\nu_\tau$  and anti- $\nu_\tau$   
In the tau into muon decay channel

	CC DIS (W)	CC DIS (Fe)
$N_{\nu_e}$	$6.8 \times 10^4$	$1.6 \times 10^5$
$N_{\nu_\mu}$	$2.0 \times 10^5$	$4.6 \times 10^5$
$N_{\nu_\tau}$	$2.1 \times 10^3$	$5.1 \times 10^3$
$N_{\bar{\nu}_e}$	$1.4 \times 10^4$	$3.7 \times 10^4$
$N_{\bar{\nu}_\mu}$	$4.4 \times 10^4$	$1.1 \times 10^5$
$N_{\bar{\nu}_\tau}$	$1.5 \times 10^3$	$3.8 \times 10^3$

Interactions per year

CERN-SPSC-2025-039

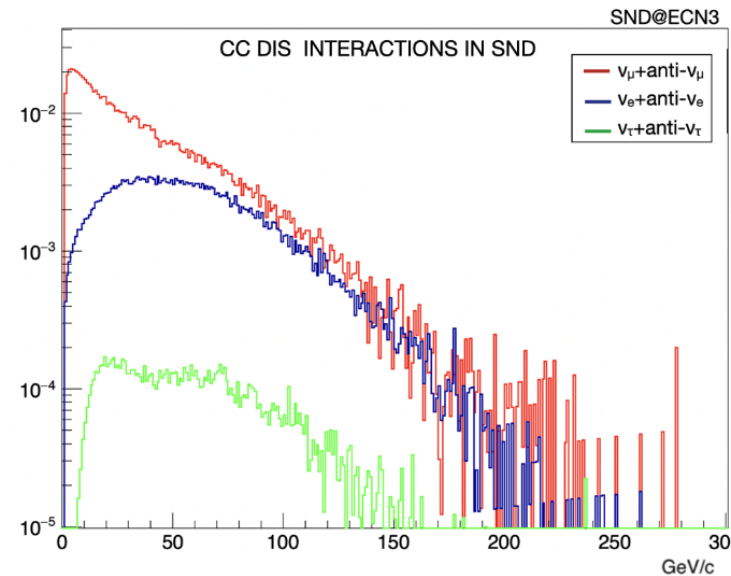

CERN-SPSC-2023-033 / SPSC-P-369



# Hadron Cascade Production

- Significant contribution to heavy flavour production due to large target thickness
- Increase both to neutrino and new particle production
- Original study in 2015 shows 2.3 (1.7) more charm (beauty) hadrons than from primary interaction only

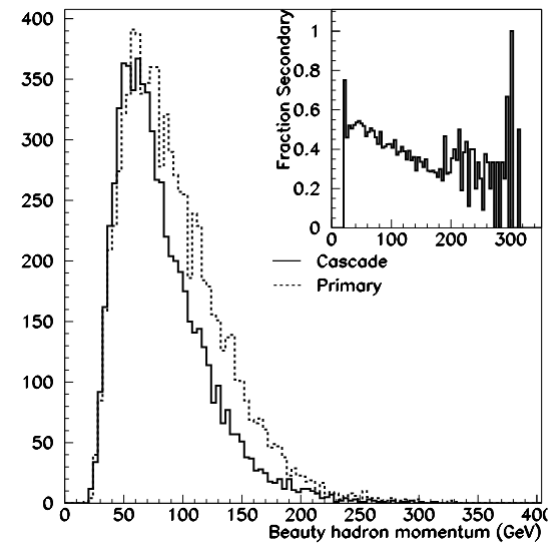
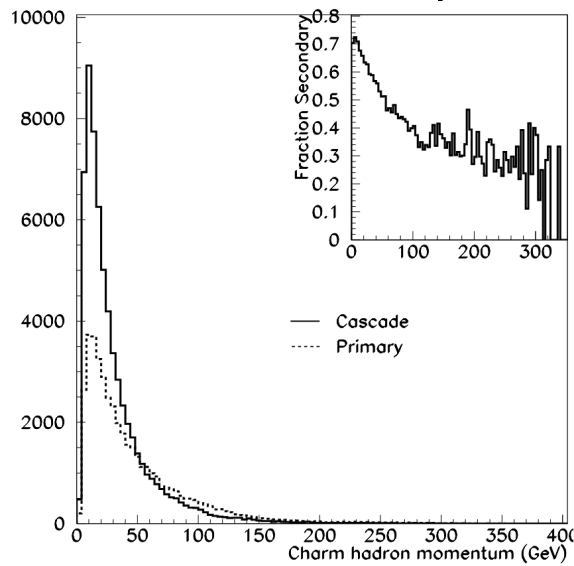

CERN-SHIP-NOTE-2015-009



# Update of the Cascade Study

- Due to Pythia6 deprecation, validate with Pythia8
- Update tune with real test-beam data, taken in 2018
- Measuring vertices in emulsions at different depths, separation between primary and secondary interactions

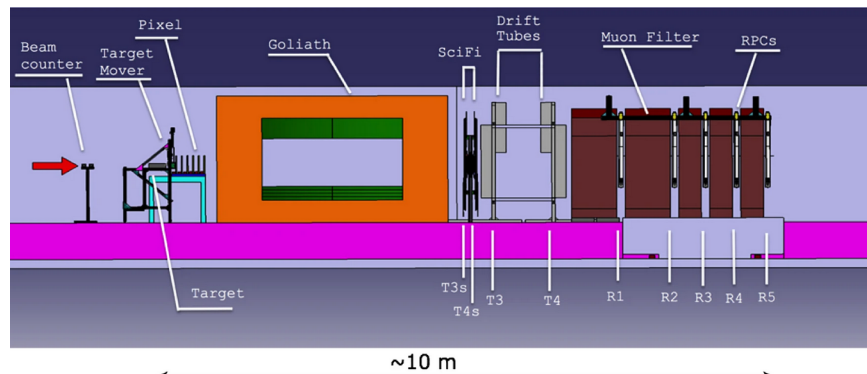

Eur. Phys. J. C 84

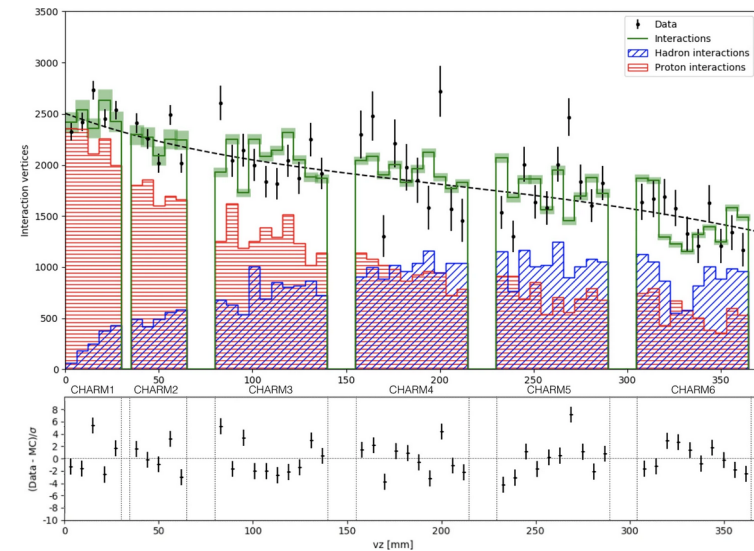

# Charm production at the SPS

- Main source of systematics: charm production uncertainty
- Focusing on measurement taken in similar experimental conditions
- Charm production in NA27
- Ds to  $\tau$  measurements from NA65
- Dedicated charm measurements in the SHiP target under preparation

Dedicated charm measurements in the SHiP target under preparation

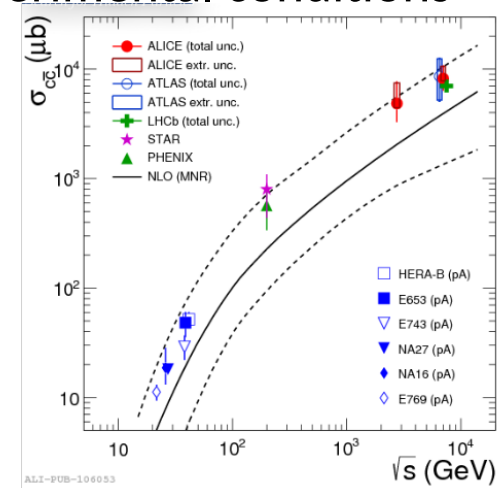
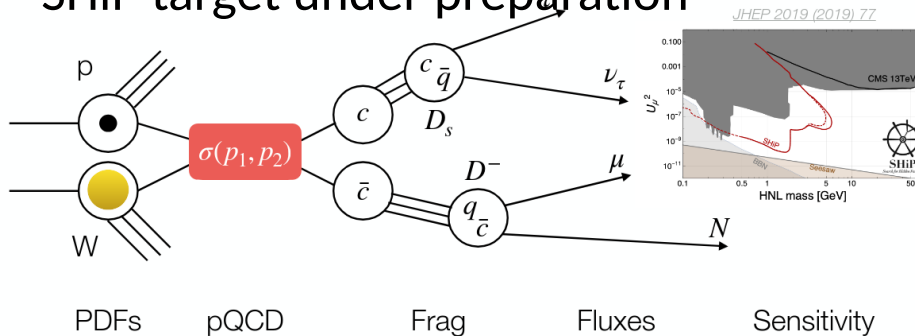

	exp NA27
$\sigma [\mu\text{b}]$	$18.1 \pm 1.7$

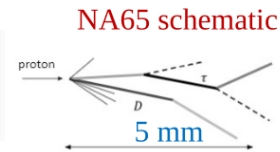

Diagram from K. Skovpen

Experiment	$D^+/D^0$	$D^0(\text{from } D^*)/D^0$	$D_s^+/D^0$
WA92: 350 GeV $\pi^-$ on Cu	$0.423 \pm 0.012$	$0.280 \pm 0.015$	$0.160 \pm 0.037$
WA92: 350 GeV $\pi^-$ on W			$0.183 \pm 0.068$



# Di-muon measurement

- Clear signal of  $J/\psi$  from the 2018 muon flux data
- Fitted including the contribution with  $J/\psi$  (2S)
- Compared measurements of  $J/\psi$  production with Pythia6 and Pythia8 Monte Carlo, as well as NA50 data
- Precise estimate as a function of rapidity difficult because of uncertainty in underlying background

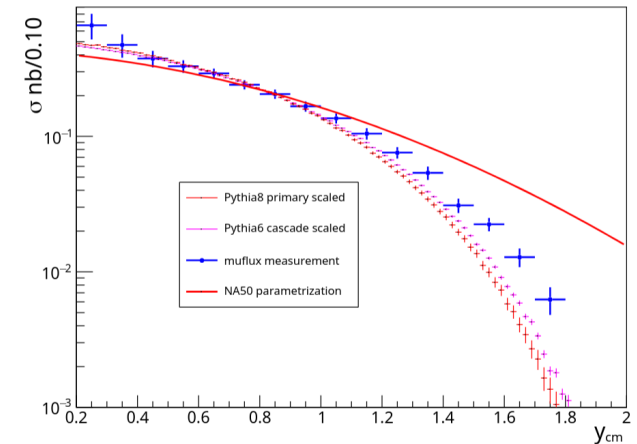
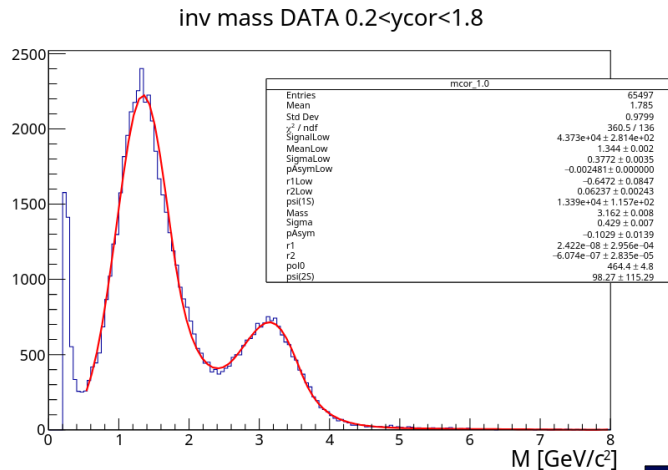

CERN-EP-2026-108



# F4 and F5 structure functions

- Effect of neutrino measurements:
  - Assessing evidence of  $F_5$
  - Measurement of  $F_4/F_5$  with 5% accuracy
- At LO  $F_4 = 0$ ,  $2xF_5 = F_2$ 
  - At NLO  $F_4 \sim 1\%$  at 10 GeV

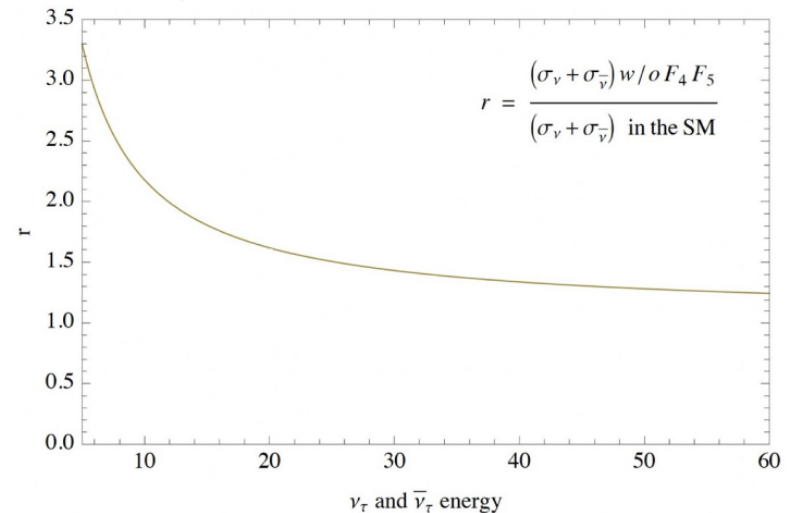
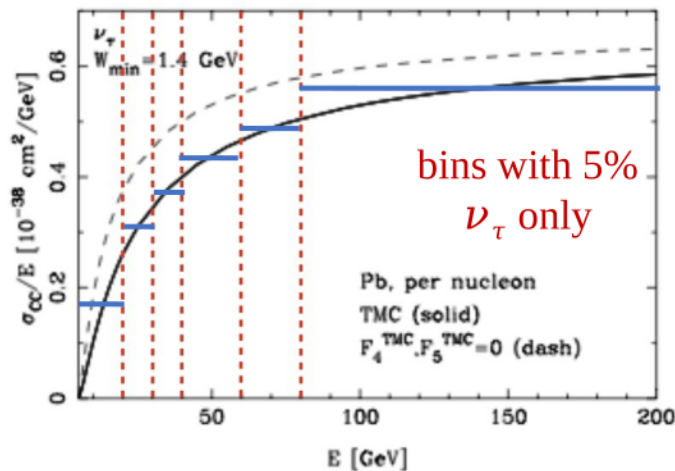

# Impact on oscillation studies

- $\nu_\tau$  cross section dominant systematic in the uncertainty in Super Kamiokande studies of the mass ordering
  - Large impact of systematics predicted in Hyper Kamiokande measurements with reduced statistics errors (<2%)
  - M. Scott (Imperial College)

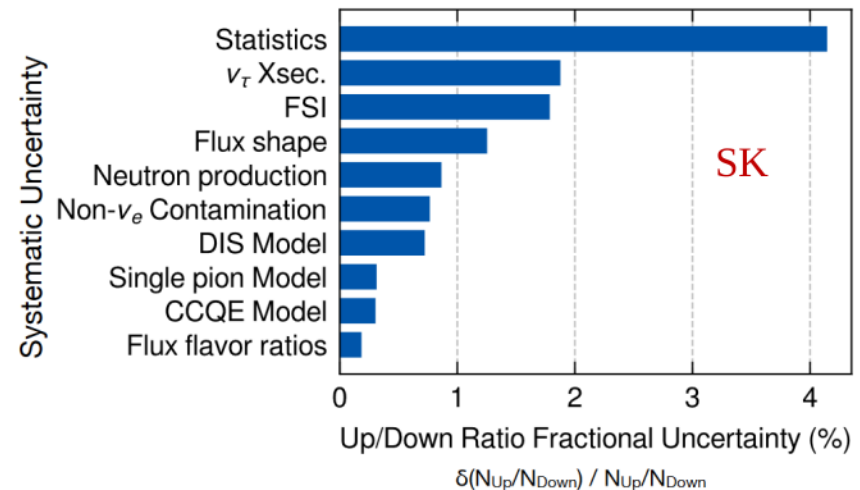
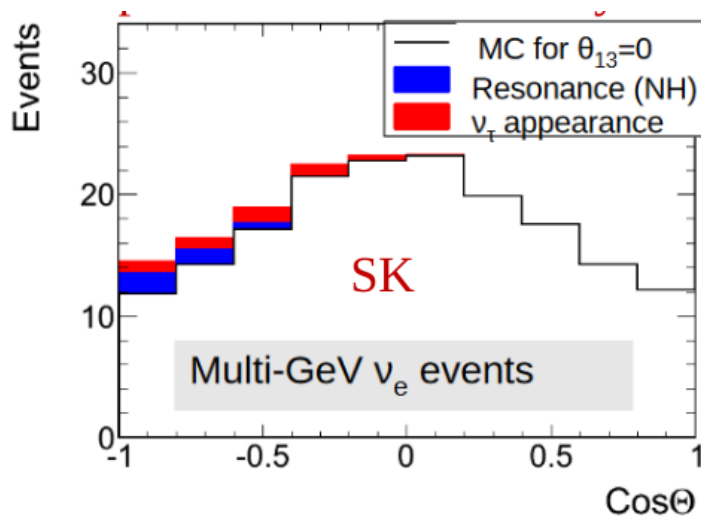

# Neutrino-induced charm production

- Charm production via anti-neutrinos dominated by s-bar quarks
- Via neutrinos shared  $\sim 50/50$  between d (valence) and s (sea)
- Explore the strangeness content of the nucleon

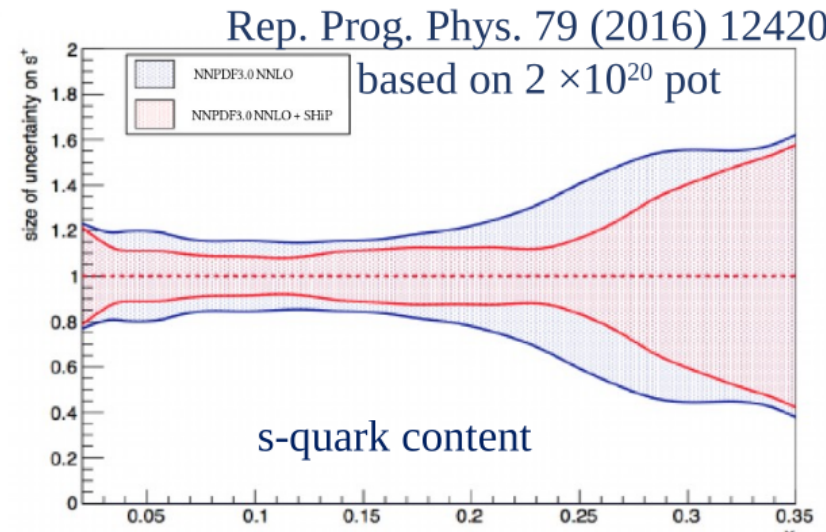
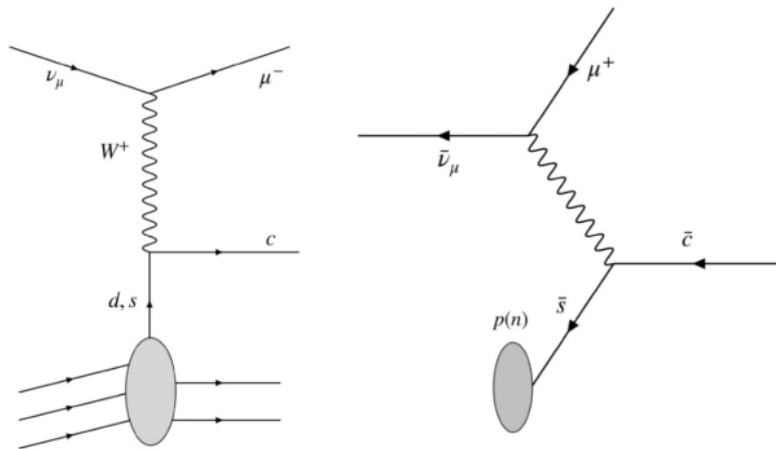

# Neutrino-induced charm production

$|V_{cd}| = 0.230 \pm 0.011$  (PDG 2022 value from neutrinos)

$B_\mu = 0.085 \pm 0.009 \pm 0.006$  (CHORUS)

$D^+ \rightarrow \mu^+ \nu$  and  $\tau^+ \nu$

- Vcd measurements by BESIII and CLEO  $|V_{cd}| = 0.2181 \pm 0.0049 \pm 0.0007$
- Plans for SHiP: to measure  $V_{cd}$  with precision close or better than 2%!
- Required excellent spatial resolution to identify the charmed hadron production and decay

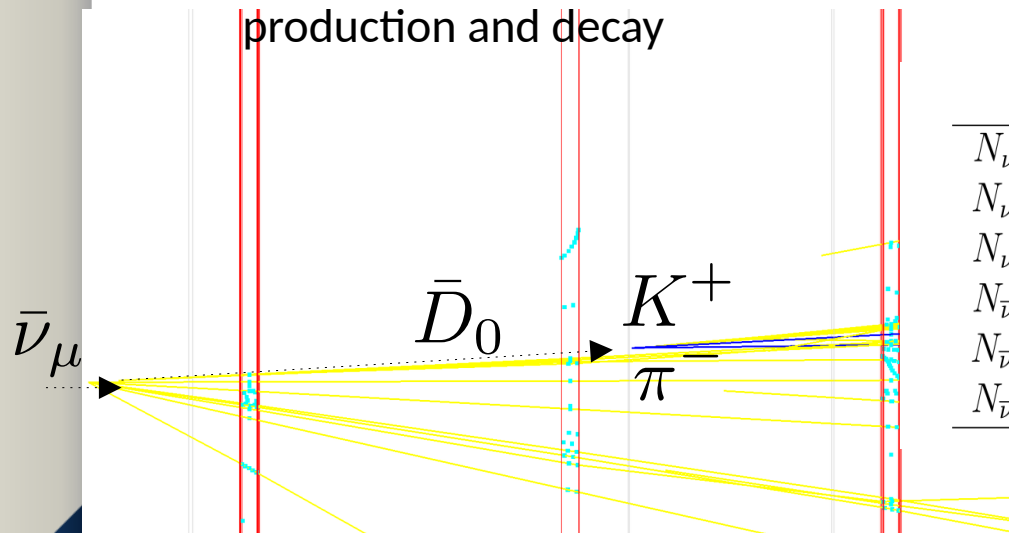

	Charm CC DIS (W)	Charm CC DIS (Fe)
$N_{\nu_e}$	$4.1 \times 10^3$	$9.8 \times 10^3$
$N_{\nu_\mu}$	$8.7 \times 10^3$	$2.0 \times 10^4$
$N_{\nu_\tau}$	$1.2 \times 10^2$	$2.8 \times 10^2$
$N_{\bar{\nu}_e}$	$7.4 \times 10^2$	$1.9 \times 10^3$
$N_{\bar{\nu}_\mu}$	$1.7 \times 10^3$	$4.1 \times 10^3$
$N_{\bar{\nu}_\tau}$	$8.6 \times 10^1$	$2.1 \times 10^2$

Interactions per year

CERN-SPSC-2025-039



# Search for light dark matter scattering

- $\chi$  particles: candidates of light dark matter  $O(\text{GeV})$
- Direct search in SND from scattering on electrons
- Topology: isolated electromagnetic shower
- Can be mimicked by neutrino interactions

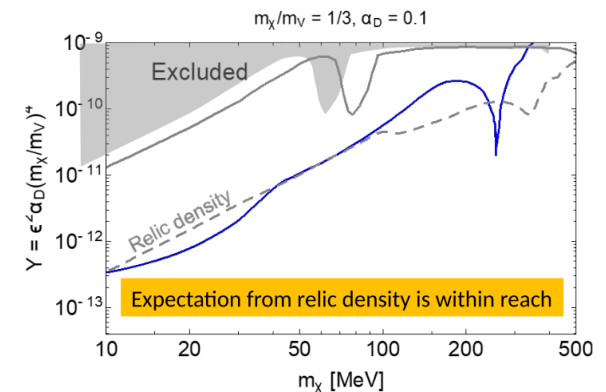
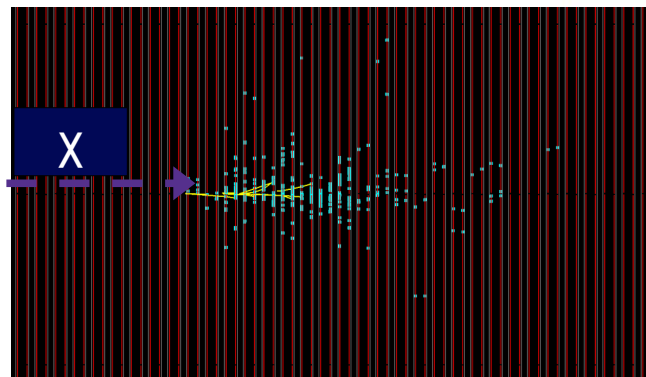
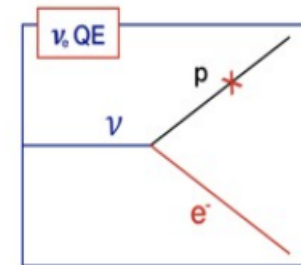
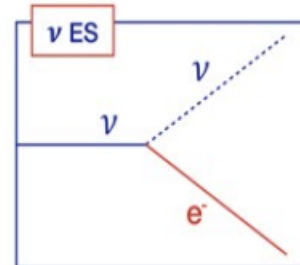
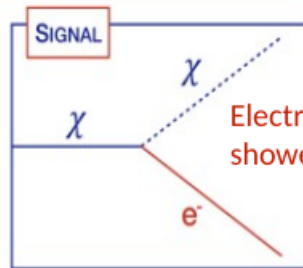

# Sinergy of SND at SPS and at LHC

- SND@LHC : Same basic principle of the SND detector for SHiP, optimized for the higher LHC energies
- Currently taking data in Run 3, results of this analysis to be combined with the SHiP neutrino measurements
- Currently emulsion/W target, will use Si/W in the High-Lumi upgrade for LHC Run4, in 2030



# Neutrino measurements by SND@LHC

- Signal ( $1 \mu$ ) : small fiducial volumes and high purity selection
- Observed 8 neutrino events in 2022 data, with 0.09 background
- An updated paper with the latest data currently in preparation

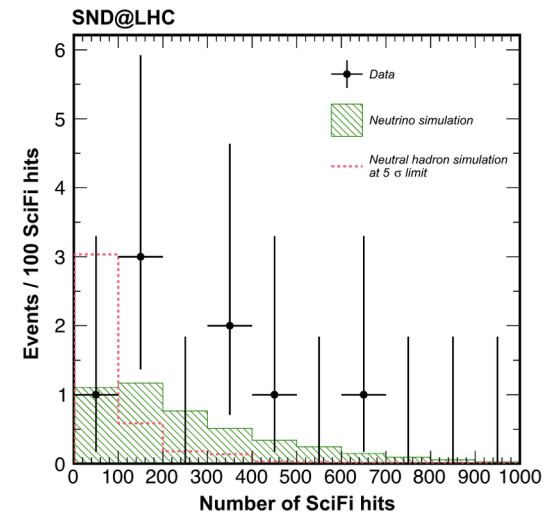
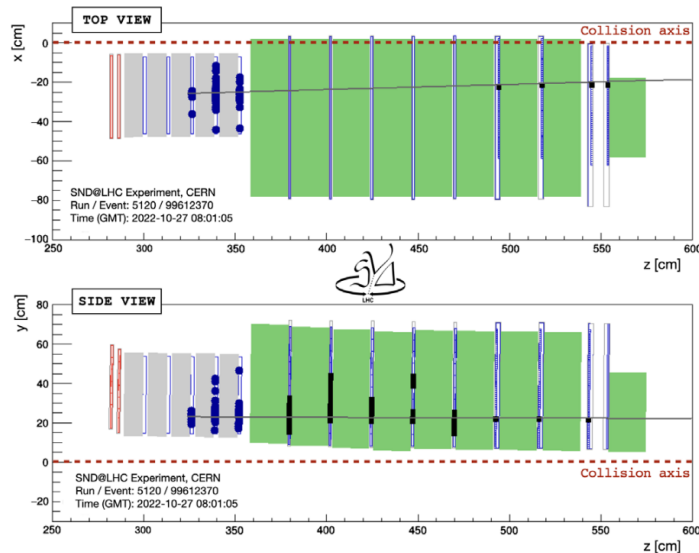

Phys. Rev. Lett. 131, 031802 (2023)



# Collider neutrinos without final state muons

- Signal ( $0 \mu$ ) :  $\nu_e$  CC +  $\nu_\tau$  CC (except  $\tau \rightarrow \mu$ ), NC
- Background assessment from neutral hadrons :
  - Total expected background :  $0.32 \pm 0.06$
- Observed 9 events
  - Significance  $6.4 \sigma$

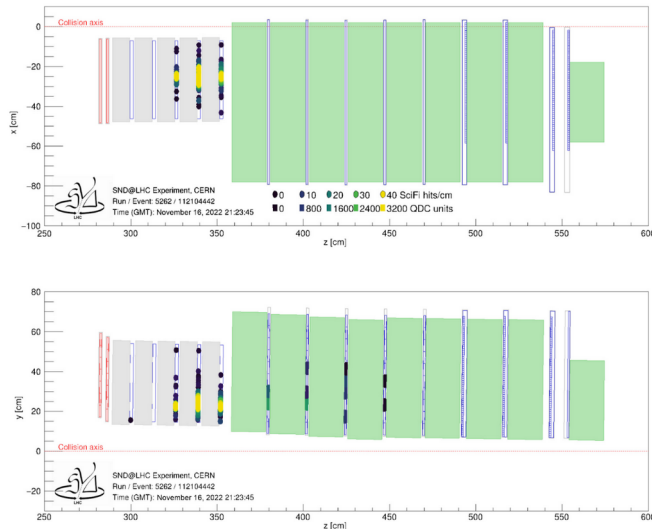

Phys. Rev. Lett. 134, 231802 (2025)

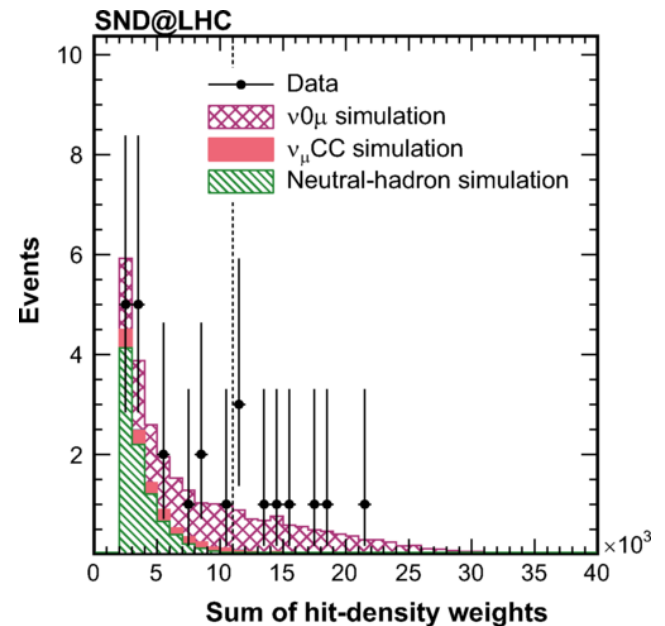

# The SND@LHC detector upgrade

- For High-Lumi, planned an upgrade of SND@LHC detector
- High intensity environment : prompt for similar technologies for SND detectors between HL-LHC and SHiP
- Neutrino Target in Si/W, followed by a Magnetised Calorimeter

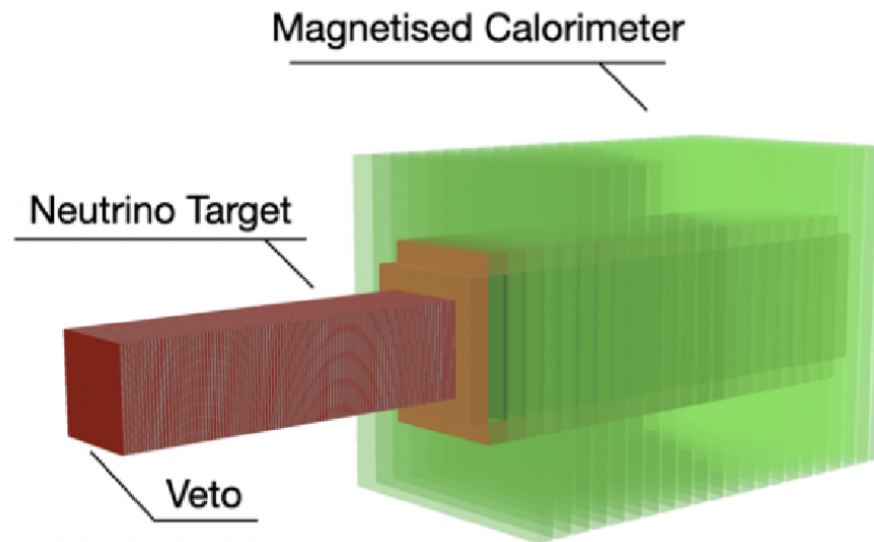

# Expected neutrino events in HL-LHC

- Estimated neutrino yield with a  $3000 \text{ fb}^{-1}$  integrated luminosity
- Assumed a detector target with 1.3 ton tungsten mass
- Discrimination between  $\nu$  and anti- $\nu$  allows to refine theoretical hadronization models

Flavour	CC DIS			NC DIS		
	DPMJET		POWHEG+P8	DPMJET		POWHEG+P8
	$\pi/K$	charm	charm	$\pi/K$	charm	charm
$\nu_\mu$	$9.6 \times 10^3$	$1.4 \times 10^3$	$1.5 \times 10^3$	$3.0 \times 10^3$	$4.2 \times 10^2$	$4.4 \times 10^2$
$\bar{\nu}_\mu$	$3.1 \times 10^3$	$9.9 \times 10^2$	$6.8 \times 10^2$	$1.1 \times 10^3$	$3.7 \times 10^2$	$2.5 \times 10^2$
$\nu_e$	$5.0 \times 10^2$	$1.6 \times 10^3$	$1.5 \times 10^3$	$1.4 \times 10^2$	$4.9 \times 10^2$	$4.5 \times 10^2$
$\bar{\nu}_e$	$2.0 \times 10^2$	$1.1 \times 10^3$	$6.9 \times 10^2$	$6.0 \times 10^1$	$4.2 \times 10^2$	$2.5 \times 10^2$
$\nu_\tau$	—	$2.2 \times 10^2$	$9.3 \times 10^1$	—	$7.6 \times 10^1$	$3.0 \times 10^1$
$\bar{\nu}_\tau$	—	$5.7 \times 10^1$	$5.0 \times 10^1$	—	$2.5 \times 10^1$	$2.0 \times 10^1$
Tot	$1.3 \times 10^4$	$5.4 \times 10^3$	$4.5 \times 10^3$	$4.3 \times 10^3$	$1.8 \times 10^3$	$1.4 \times 10^3$

LHCC-P-026

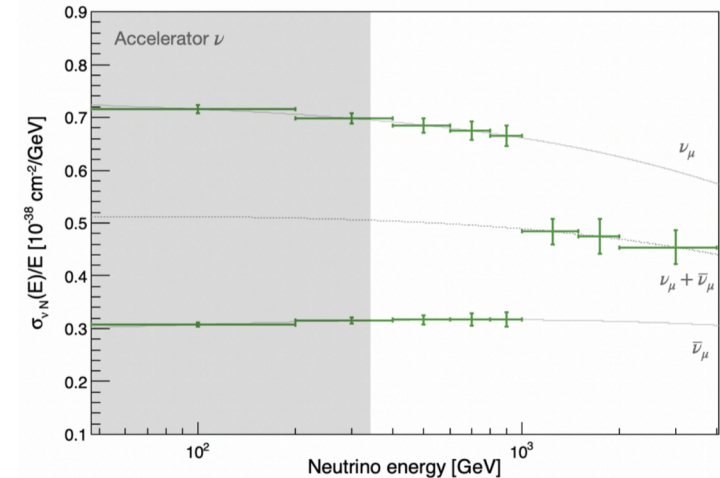

# Timeline of the SHiP experiment

- Now : preparation of the Technical Design Report
- Start of data taking : 2033, preliminary configuration in Run 4
- Long Shutdown 4 : experiment consolidation, final installation
- Run 5 : data taking with the complete SHiP detector



# Conclusions

- New Beam Dump Facility at the CERN SPS, wide physics scope of SHiP
- Exploring new physics in the Hidden Sector
- For the neutrino side : high statistics, many physics studies possible
- International Collaboration with 18 Countries, 34 Institution
- Steering towards experiment installation and data taking
- Many open items to study both on detector and on simulation

