

HORN STUDIES FOR SPL-SUPERBEAM

Christoph Bobeth
IPHC Strasbourg

Phone meeting – 15th April 2010

- Energy deposition in target
 - ⇒ Study of integrated target as inner horn conductor
(work in progress with Gérard Gaudiot and Benjamin Lepers)
- Shape optimisation
 - ⇒ NuFact-horn

Integrated target energy deposition

INTEGRATED TARGET

Idea put forward by Chris Densham:

Integrate the target as inner conductor inside the horn

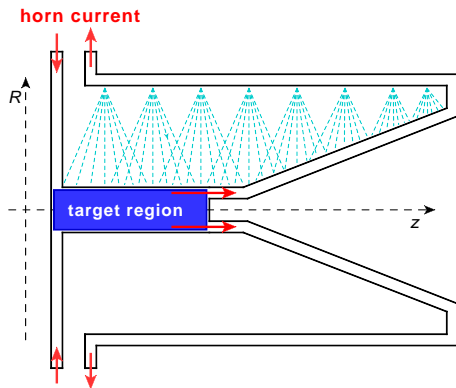

Requirement

- conducting target material

Advantages

- lower inner radius \rightarrow higher magnetic field or lower horn current
- can use water cooling of inner horn conductor also for target cooling

TARGET & BEAM - PARAMETERS

GEOMETRY target length $L^{tg} = 78$ cm and radius $R^{tg} = 15$ mm

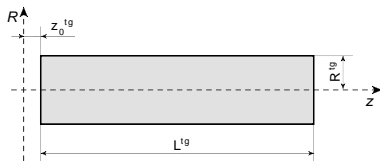

MATERIAL target: low- Z materials: **Beryllium, Aluminium, AlBeMet**, comparing to Carbon – high- Z materials perhaps interesting too, but give more neutrons

BEAM proton beam,
kinetic energy $E_{\text{kin}}^{bm} = 4.5$ GeV,
beam power 4 MW,
frequency 50 Hz,
pulse duration $\lesssim 5 \mu\text{s}$
gaussian beam profile $\sigma^{bm} = \{2, 4, 6\}$ mm

ENERGY DEPOSITION

Neglecting pulsed structure of beam = assuming continuous energy deposition of proton beam @ 4 MW and $E_{\text{kin}}^{bm} = 4.5$ GeV.

material	density [g/cm ³]	σ^{bm} [mm]	max value power density [kW/cm ³]	total power [kW]
Be	1.85	2	11.65	168.7
		4	3.25	165.3
		6	1.53	153.2
C	1.85	2	13.22	200.0
		4	3.57	196.5
		6	1.72	182.2
Al	2.70	2	19.26	285.6
		4	5.36	279.1
		6	2.73	257.4
AlBeMet (Be 61%, Al 38%, O 1%)	2.1	2	14.11	204.4
		4	3.92	200.1
		6	1.86	185.2

The maximal value of deposited power density and the total power deposited in the target at different values of the beam width.

Divide by 4 in the case of 4 target-horn stations.

ENERGY DEPOSITION - DISTRIBUTION

... in 1) $z - R$ plane and 2) R for fixed values of z

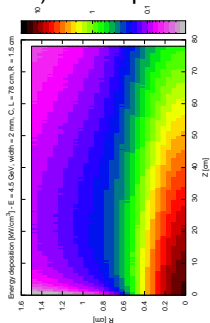

C-target $\sigma^{bm} = 2$ mm

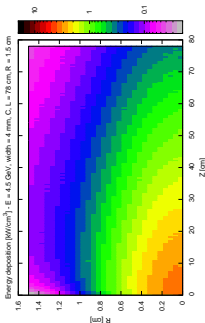

C-target $\sigma^{bm} = 4$ mm

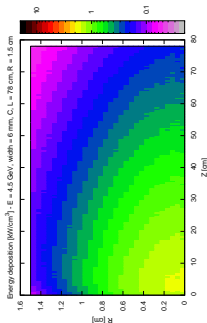

C-target $\sigma^{bm} = 6$ mm

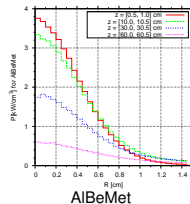
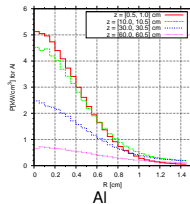
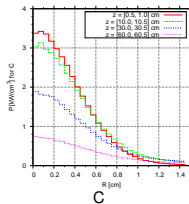
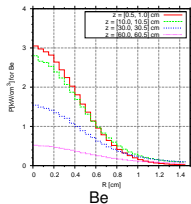

ENERGY DEPOSITION - DISTRIBUTION

... in 3) for z and fixed $R \in [0.0, 0.5]$ mm = along “z-axis”

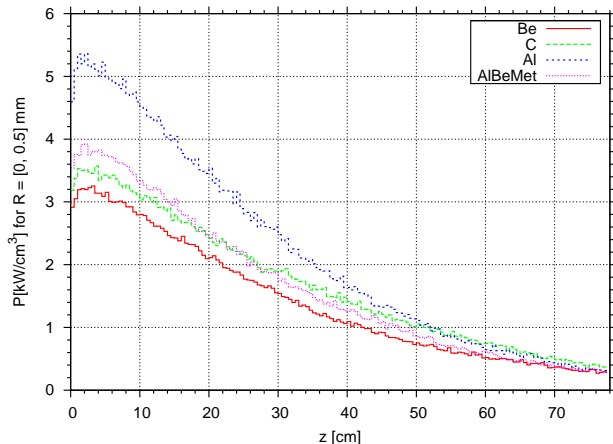

... to be continued with first estimates of final temperature by Benjamin Lepers

Shape optimisation NuFact-horn

HORN – SHAPE OPTIMISATION

... various ideas

PROBLEM: A GOOD CRITERIA FOR OPTIMISATION

- sensitivity of physics parameters (θ_{13}, δ_{CP}), BUT requires full simulation and also details on detector
- optimise ν spectrum in solid angle corresponding to detector \rightarrow still too time consuming, requires full simulation of target, horn, decay tunnel and beam dump
- optimise π spectrum after exiting horn

... OPTIMISE π SPECTRUM AFTER EXITING HORN

- Using simple numerical Euler-integr. for fast π tracking through magnetic field
- Checked agreement with FLUKA, accuracy depends on stepwidth = compromise for smaller CPU time
- Could be improved using symplectic integr. algorithm. Has somebody experience? Suggestions and help are welcome.

π DECAY KINEMATICS

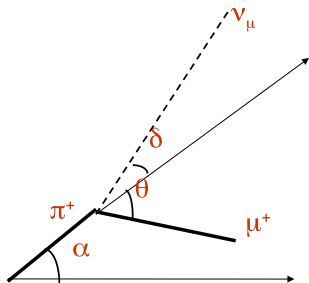
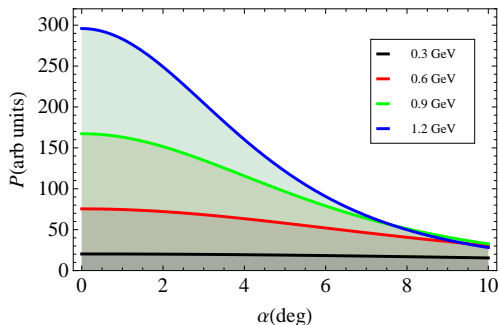

Probability of ν_μ hitting detector depends on π -momentum and angle ($\delta = -\alpha$)
→ more important to focus π 's with large momentum

$$P(\alpha, L) = \frac{1}{4\pi} \frac{A}{L^2} \frac{1-\beta^2}{(1-\beta \cos \alpha)^2} \quad \text{for} \quad \dim(\text{decay tunnel}) \ll L$$

Accept π as “good” (or “background” for opposite charge), if α such that

$$P(\alpha) > 1/2 \times P(0)$$

REOPTIMISING NUFACT HORN - PARAMETERS

- optimizing for longer Carbon target $L^{tg} = 78$ cm (previous Hg $L^{tg} = 30$ cm)
- removing reflector with current $I = 600$ kA introduced by Campagne/Cazes

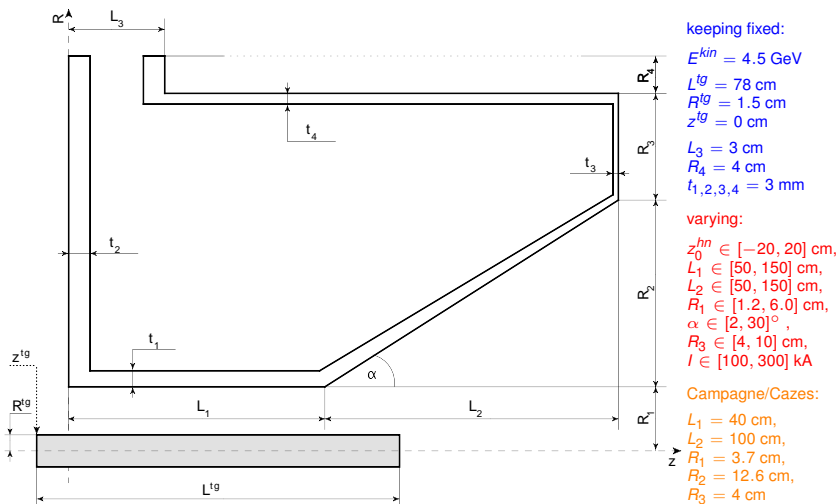

REOPTIMISING NUFACT HORN - SCAN

- use π sample generated with FLUKA for C-target 10^6 pot yielding 759914 π^+ and 498397 π^- at target exit (position, momentum)
- optimise horn for π^- focusing, since background suppression more important for $\bar{\nu}_\mu$ -run
- look for optimal ratio

$$R(\pi^-/\pi^+) = (\# \text{ of "good" } \pi^- \text{ with } p > 0.5 \text{ GeV}) / (\# \text{ of "background" } \pi^+)$$

- selection in plots:

red = $(R(\pi^-/\pi^+) < 20) \ \&\& \ (18000 < \# \text{ of "good" } \pi^- \text{ with } p > 0.5 \text{ GeV})$

green = $(R(\pi^-/\pi^+) < 30) \ \&\& \ (20000 < \# \text{ of "good" } \pi^- \text{ with } p > 0.5 \text{ GeV})$

PARAMETERS VS $R(\pi^-/\pi^+)$

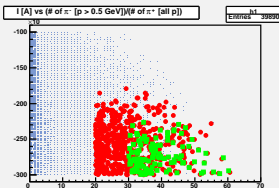
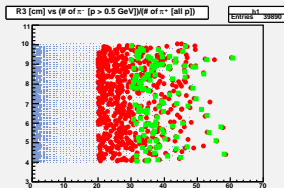
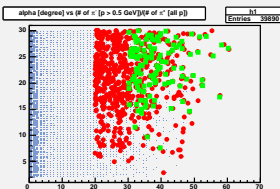
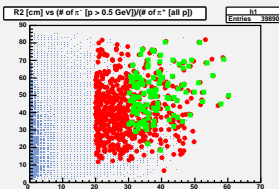
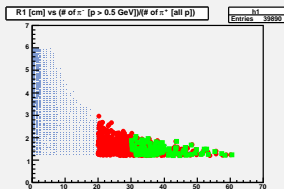
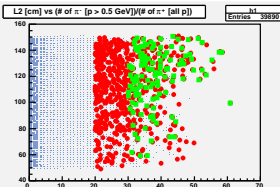
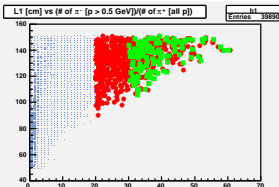
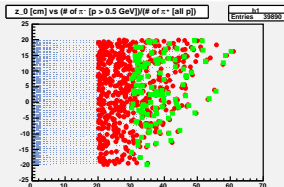

PARAMETERS VS (# OF “GOOD” π^- WITH $p > 0.5$ GeV)

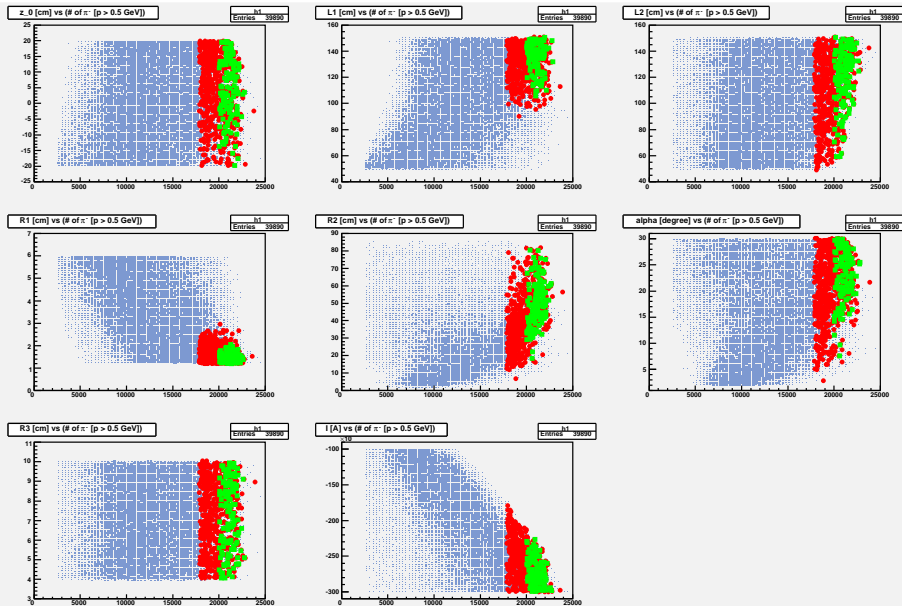

“BEST” 13 HORNS

z_0 [cm]	L_1 [cm]	L_2 [cm]	R_1 [cm]	R_2 [cm]	R_3 [cm]	I [A]	$R(\pi^-/\pi^+)$	# of π^-
9.5	132.9	148.9	1.22	38.8	8.9	-290363	48.1	20832
16.6	149.5	136.2	1.60	65.6	7.8	-260182	48.5	20849
19.8	140.4	125.0	1.45	70.4	8.8	-284804	49.3	20359
-3.17	147.0	133.0	1.20	51.8	7.3	-252144	49.7	21316
16.8	135.6	148.2	1.37	80.7	6.7	-297522	51.1	21277
19.5	132.5	118.4	1.23	57.6	8.5	-265272	51.9	20147
13.0	149.5	124.4	1.46	46.4	9.2	-284583	52.2	21002
13.1	145.7	145.3	1.43	52.0	6.4	-295798	52.3	21667
1.31	148.9	122.2	1.24	68.5	5.5	-270165	54.0	21269
4.21	147.2	131.4	1.31	61.7	5.1	-294389	55.0	22608
12.6	142.4	139.2	1.22	43.9	5.8	-297794	57.8	20984
15.0	140.4	138.3	1.20	71.6	4.4	-278077	58.9	21142
15.8	141.0	98.34	1.22	49.3	9.3	-296638	60.2	21369
0.0	40.0	100.0	3.70	12.6	4.0	-300000	??	??

Horns become large $L \sim 3$ m and $R \sim (0.5 \dots 1)$ m – even larger?

To be done:

- check final $\sin^2(2\theta_{13})$ and δ_{CP} sensitivities
- check material effects (horn, decay tunnel)

“BEST” 13 HORNS

Horns

