



Analytical Modeling of Mismatch-Induced Noise in Space-Grade differential Low Noise Amplifiers

That Minh Bao TON
Astroparticules et Cosmologie Laboratoire (APC)



How to capture and map X-ray

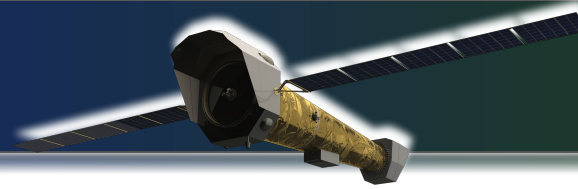

Scientific contexts



Transition-Edge Sensor (TES)

A cryogenic thermometer

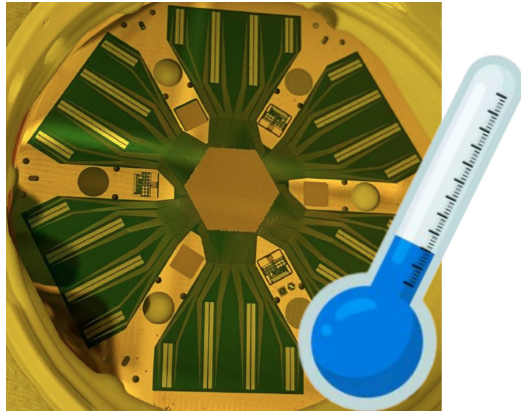

Array of 1504 detectors
(NASA/GSFC)

(More TES detail in Elisa's presentation)

Superconducting Quantum Interference Device (SQUID)

"Listen, amplify, convert"

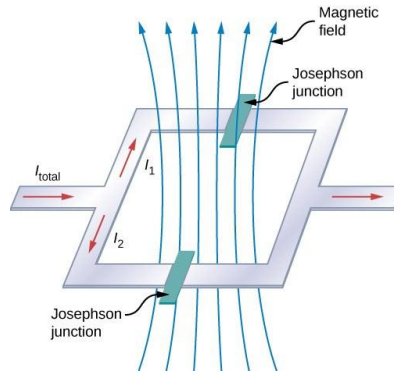

Low noise Amplifier

"Make it bigger"

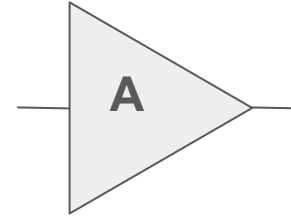

Digitalization

Make it "machine readable"



How to capture and map X-ray?

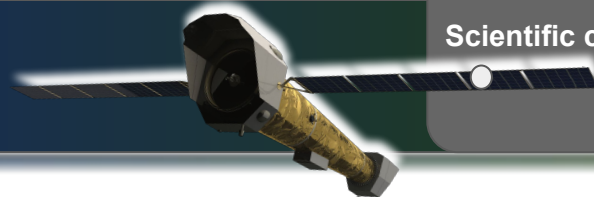

Transition-Edge Sensor (TES)

A cryogenic thermometer

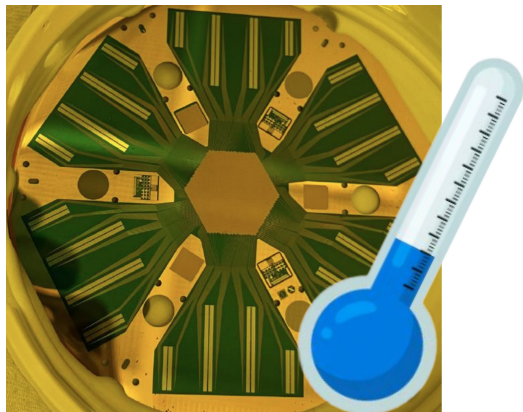

Array of 1504 detectors
(NASA/GSFC)

Superconducting Quantum Interference Device (SQUID)

“Listen, amplify, convert”

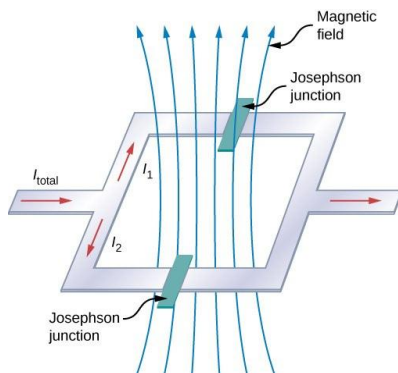

Low noise Amplifier

“Make it bigger”

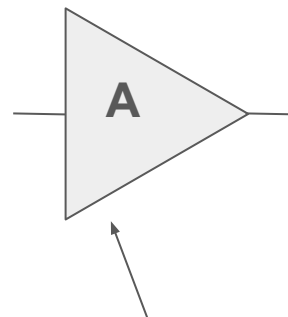

Digitalization

Make it “machine readable”

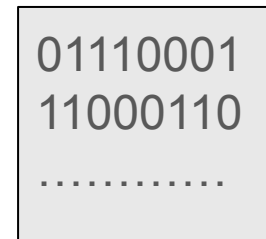

Very important:

Amplify, but **not adding** so much
“electronic **noise**” to signal



- **Definition:** Random, **unwanted** electrical fluctuations in devices.
- **Significance:** **Degrades** the quality of the scientific signal.
- **Characterization:** We study noise through its **Noise Spectrum**

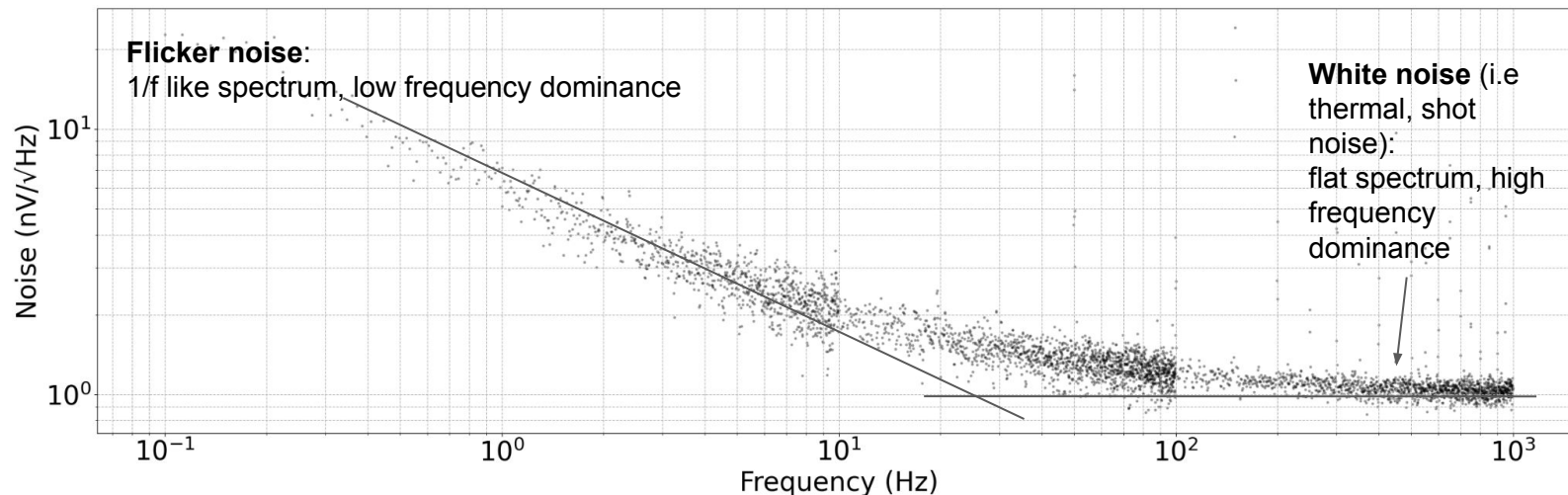

- **Problem:** External noise (from sources like radio frequency interference, power supply, or poor grounding) can **also be amplified** by the LNA
- ⇒ **Reduce signal quality**
- **Solution:** Use a differential pair to **decouple the signal** and **actively reject external disturbances**.

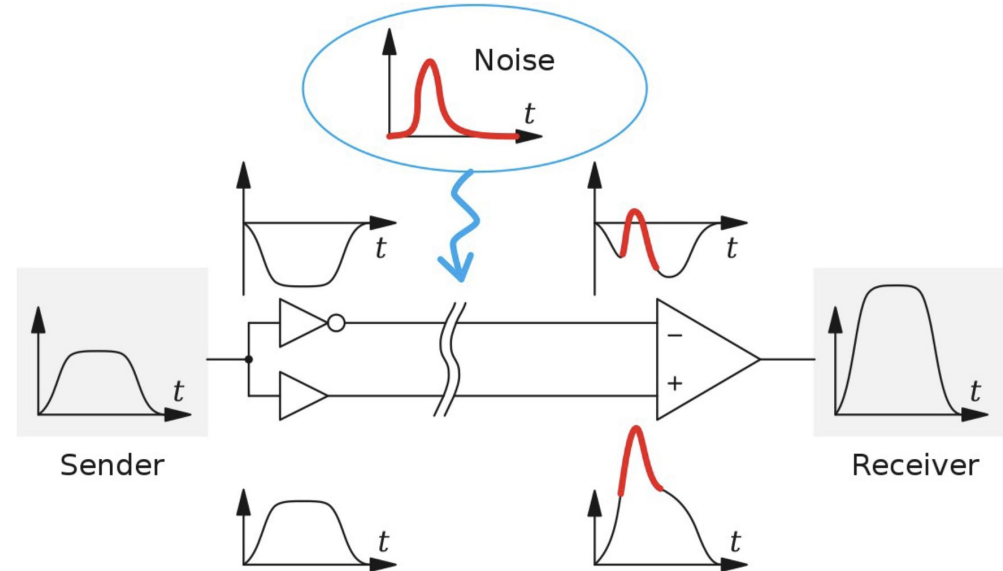

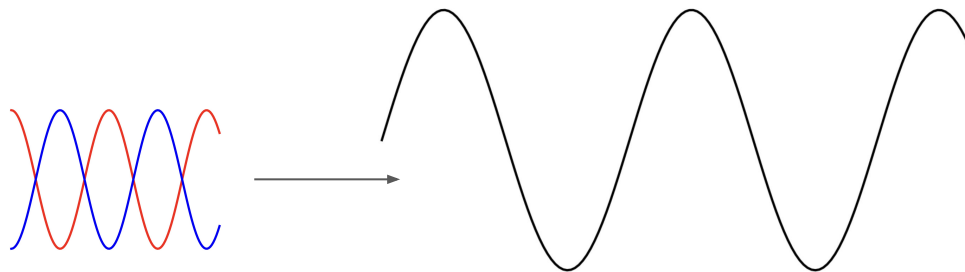
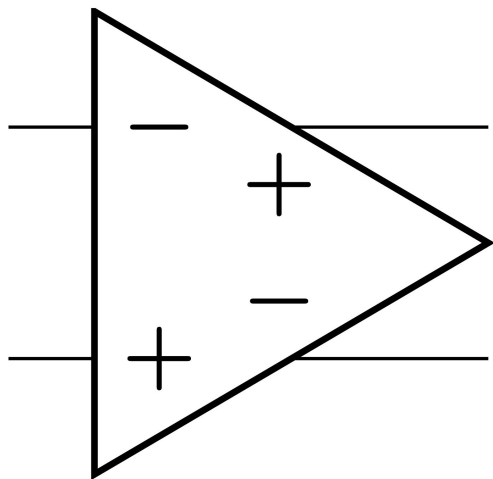

Differential gain (A_{dm}): How large signal can be amplify



Common-mode to differential gain (A_{cm-dm}): How large “external disturbance” can be amplify.

(Ideally, this common-mode gain ≈ 0)

Differential Low-noise Amplifier Characteristics

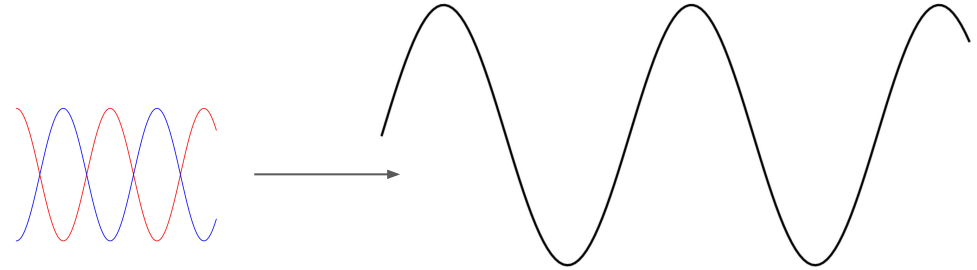
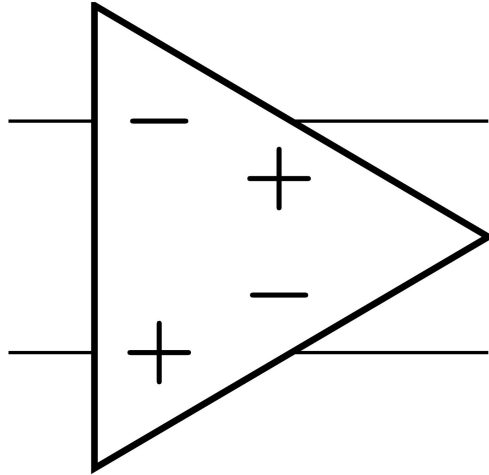

Differential gain (A_{dm}): How large signal can be amplify



Common-mode to differential gain (A_{cm-dm}): How large “external disturbance” can be amplify.

(Ideally, this common-mode gain ≈ 0)

Figure of Merit: Common-mode Rejection Ratio (CMRR)

$$CMRR \propto 1/A_{cm-dm}$$

Mismatch Problem: Common-Mode Rejection

- **Ideal:** Perfect symmetry \Rightarrow **Reject all external disturbance**
 \Rightarrow **CMRR = ∞**
- **Reality:** Component mismatches are **unavoidable**
 \Rightarrow **CMRR = finite**
- **Impact:** Degrade noise performance of LNA.
- **Sources:** Mismatches in **base resistance, load resistors,** and **transconductance.**

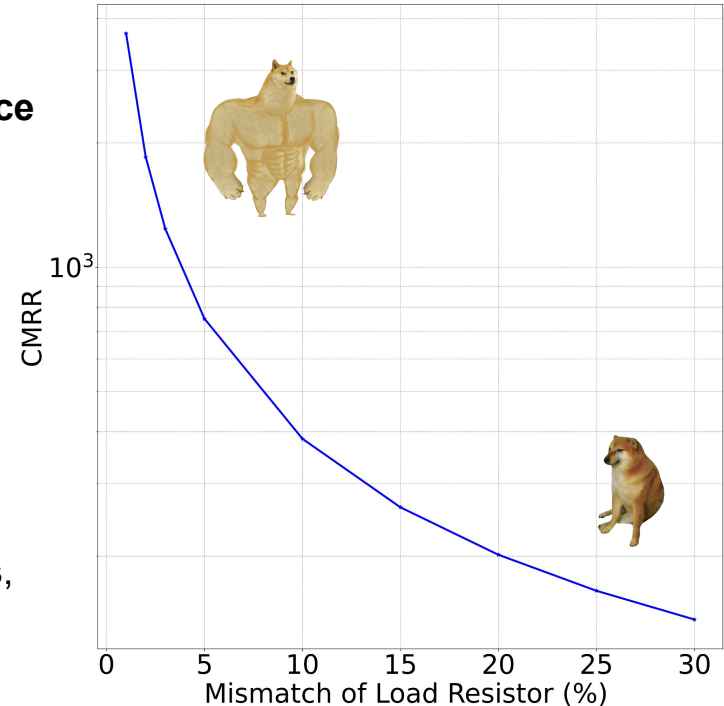

Noise performance with R Load mismatches

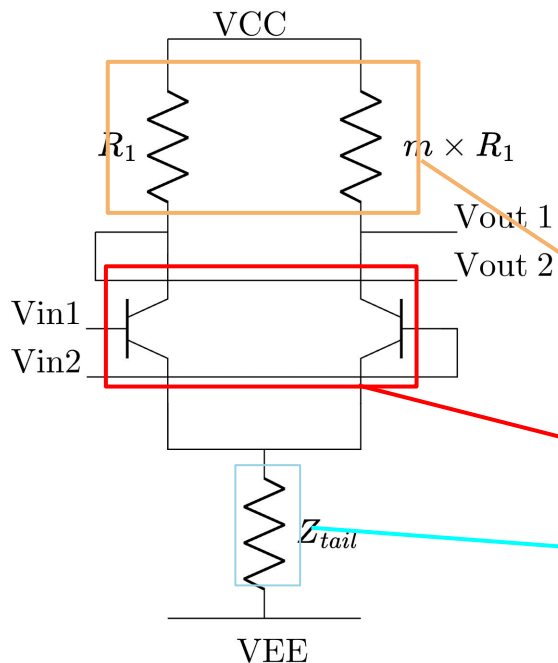

Single stage common-emitter amplifier with resistive biasing

- **Case study:** Input noise performance of single stage differential common-emitter amplifier with load mismatch.
- **Why does this important?** Input noise of the Amplifier can be the **source of disturbance** for the **TES/SQUID signal**.
- **Test component:**

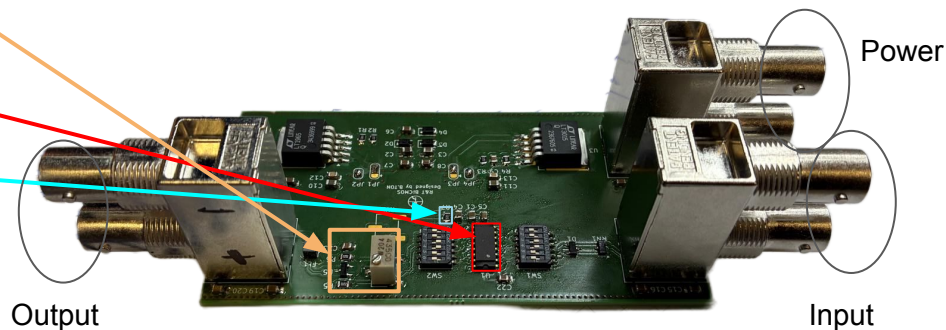

Flicker noise increase with mismatch



Simulation

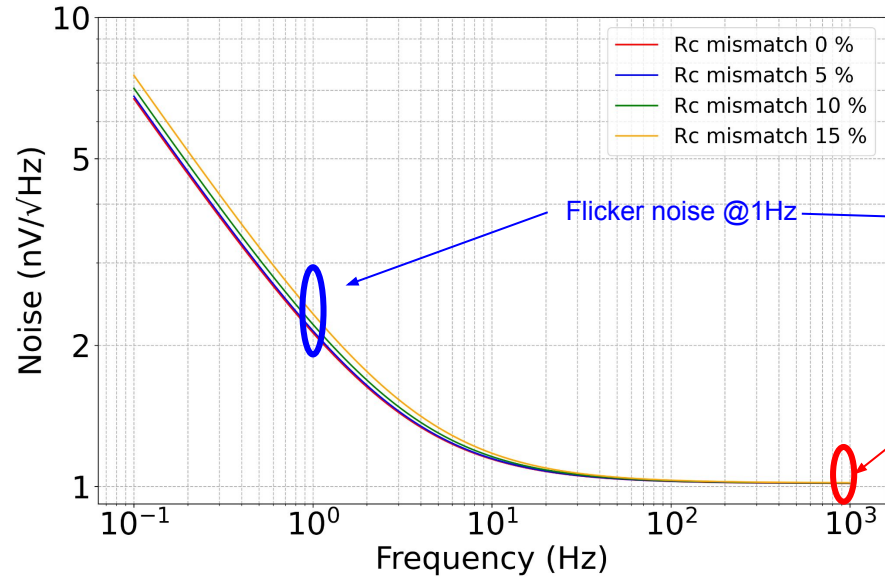

Measurement

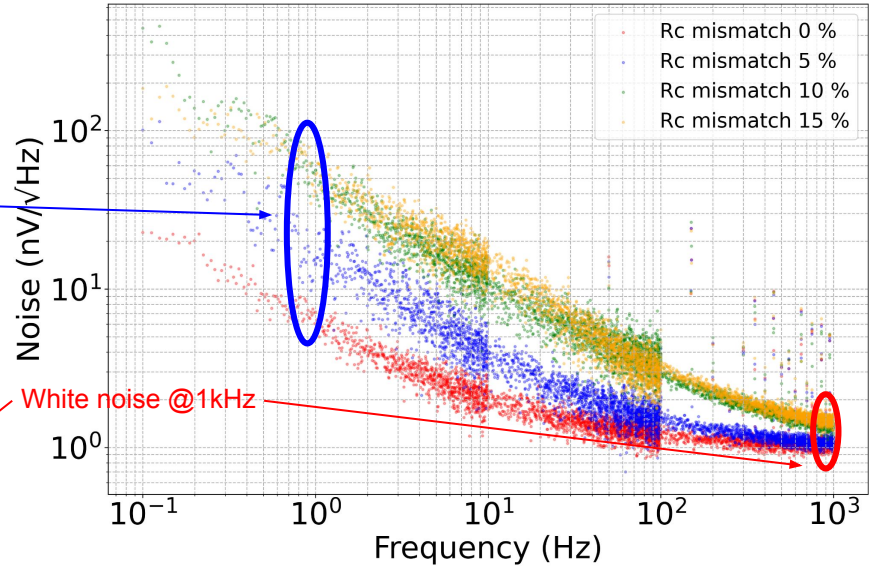

Why it is so different?



Simulations vs measurements: noise gap?

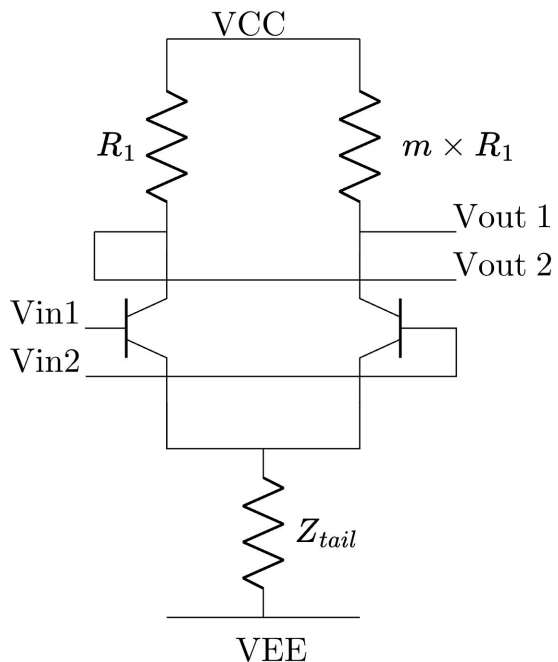

Source of noise	Simulation	Measurement
Z_{tail}	✓	✓
Power source	✗	✓
External instruments	✗	✓
Wiring connect	✗	✓
Ambient noise, thermal drift...	✗	✓

Inject more
to the input
noise when
CMRR ↘

- **Mismatch is the Enemy:** Even few % mismatch significantly degrades noise performance, leaving the **LNA** vulnerable non-simulated sources of noise.
- **The Reality Gap:** Simulations often underestimate noise, especially at **low frequencies**, by failing to account for real-world environmental factors.
- **Design Requirement:** For **space-grade** performance, we must move beyond "ideal" models and prioritize extreme symmetry in **differential pairs**.