



Evaluating EPICS as a replacement for IBA's SCADA Layer

EPICS collaboration meeting | Apr 20 – 24, 2026

Xavier Wilputte, Automation Expert



Life,
Science.

©2022 Ion Beam Applications SA. All rights reserved. Reproduction of any of the material contained herein in any format or media without the prior and express written permission of Ion Beam Applications SA is prohibited.



IBA – Global leader in particle beam technology



DOSIMETRY

#1

Quality Assurance Solutions

10k+ customers

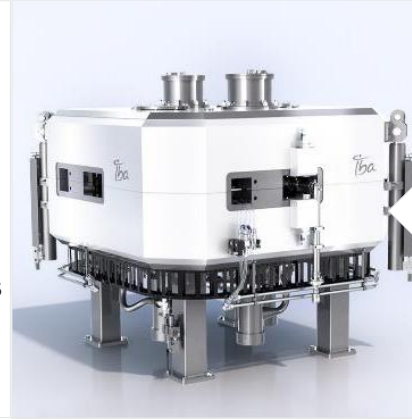

RADIOPHARMA SOLUTIONS

#1

Radioisotopes production

380+ accelerators sold

PROTON THERAPY

#1

Proton Therapy Solutions

75+ systems sold



INDUSTRIAL SOLUTIONS

#1

E-Beam & X-ray Solutions

300+ accelerators sold



Strong **Market & Innovation** Synergies

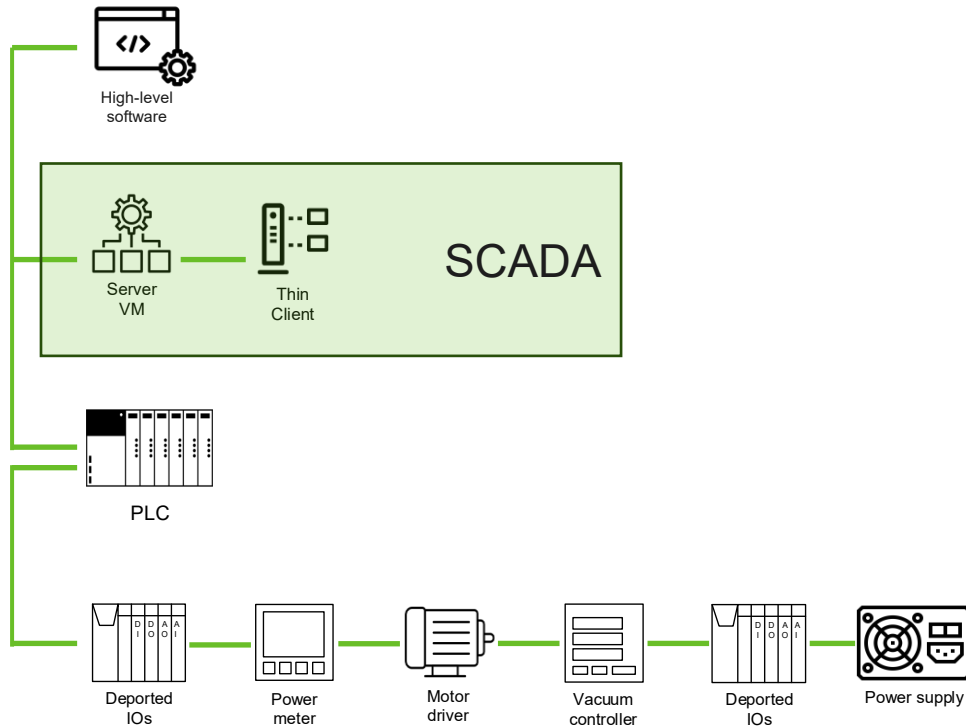

■ SCADA capabilities

- 5k to 30k PVs
- 1k to 10k Historized PVs
- 1Hz to 40Hz PV update
- Up to 5 HMI concurrent sessions
- RBAC & Audit trail

■ SCADA current pains

- Proprietary, commercially licensed technology (VMWare, Windows, Aveva)
- Tightly coupled to vendor toolchain & license model
- Growing concerns: sustainability, cost & vendor lock-in

IBA – Our **evaluation** approach

EVALUATION FRAMEWORK



- Categories
- Weighted scoring

REQUIREMENTS



- Regulations
 - Medical
 - Industrial
 - Cybersecurity
- Quality attributes
 - 24/7 availability
 - Auditability & Role base access
 - Maintainability and system remotely updatable
 - ...

CANDIDATES EVALUATION



- EPICS + Web-HMI framework
- Open-source, royalty-free license
- OPC-UA & pvAccess for PLC comms
- Proven at large-scale facilities worldwide

DEMONSTRATOR



- A comprehensive overview
- Residual uncertainties
- Performances
- Based for the IBA product impact analysis

IBA – What we are seeking?

Operational Experience



- REX in similar context
 - Configuration
 - Long term support
 - Regulated env.
- Cybersecurity hardening
“secure by design”

Know Limitations

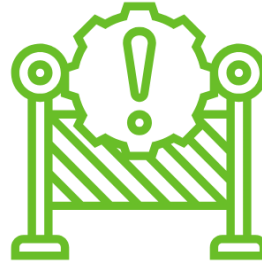

- Scalability challenges
- Web-HMI capabilities

Community & Collaboration

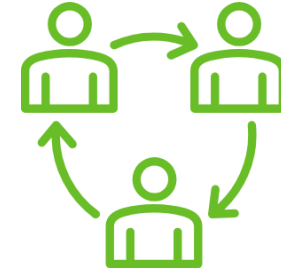

- Support pathways
- Contributing back if evaluation is positive

Xavier Wilputte

R&D Automation Expert

Xavier.Wilputte@iba-group.com



Marco Pitruzzella

R&D Automation Expert

Marco.Pitruzzella@iba-group.com



Protect, Enhance and Save Lives



Viggo Mommaerts, treated with Proton Therapy



©2021 Ion Beam Applications SA. All rights reserved. Reproduction of any of the material contained herein in any format or media without the prior and express written permission of Ion Beam Applications SA is prohibited.

Life.
Science.

