

SSH Monitor

<https://gitlab.com/sshmonitor/sshmonitor>

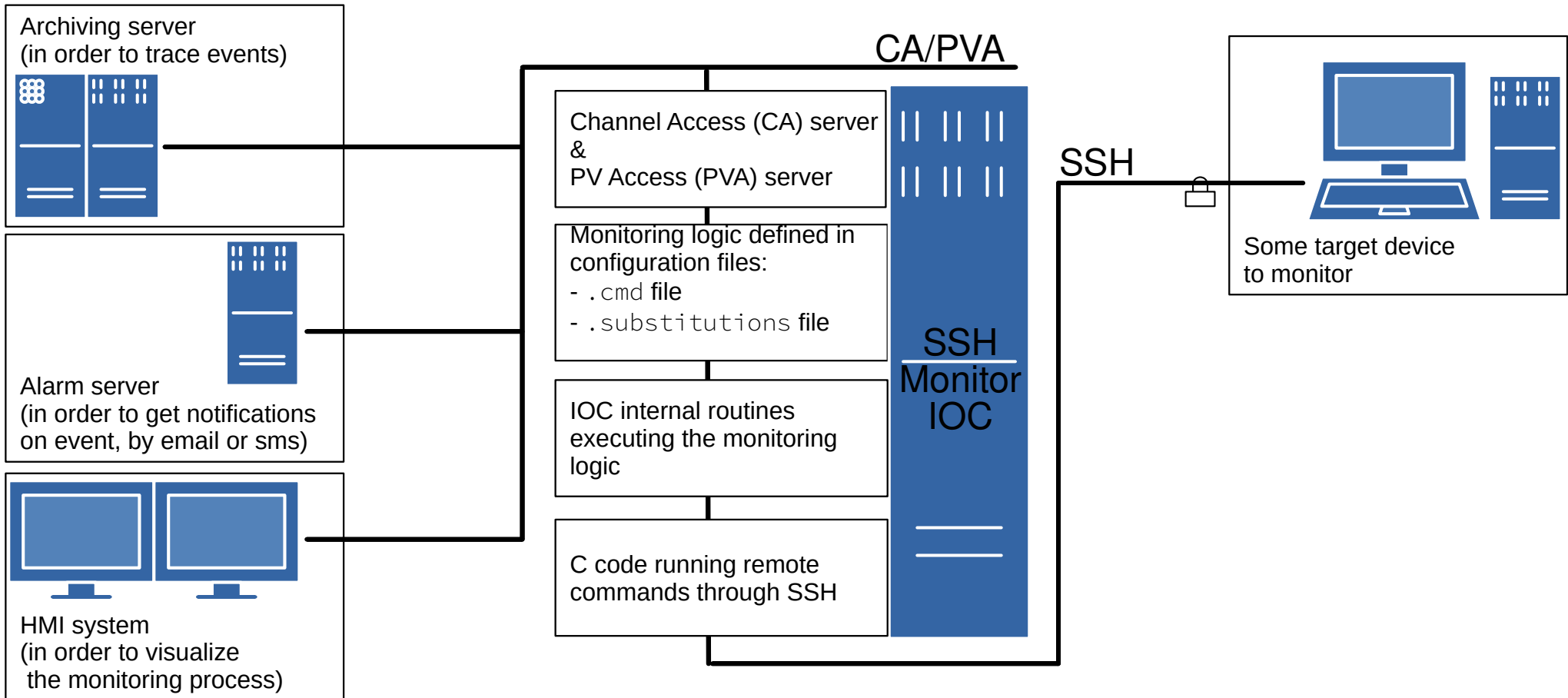

General operation



General operation

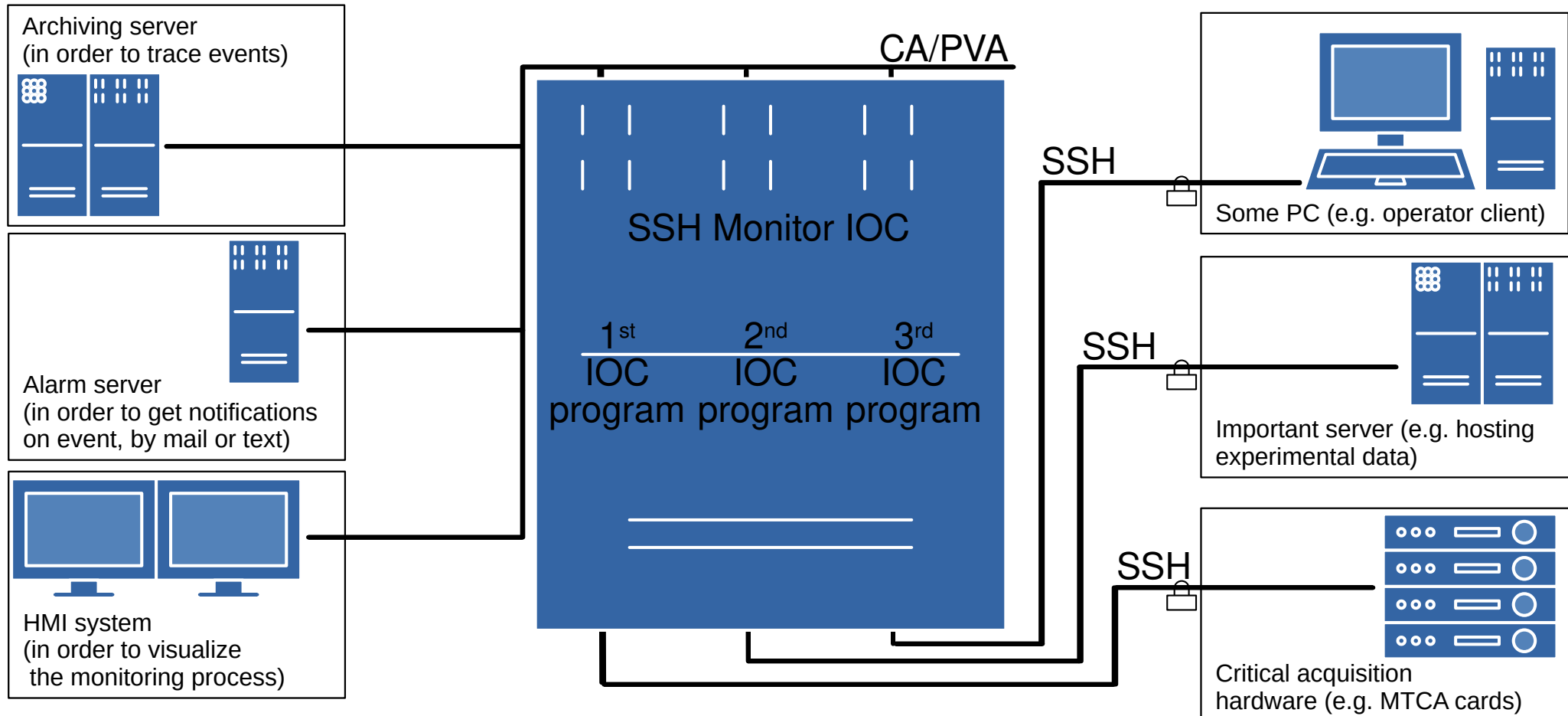

What SSH commands?

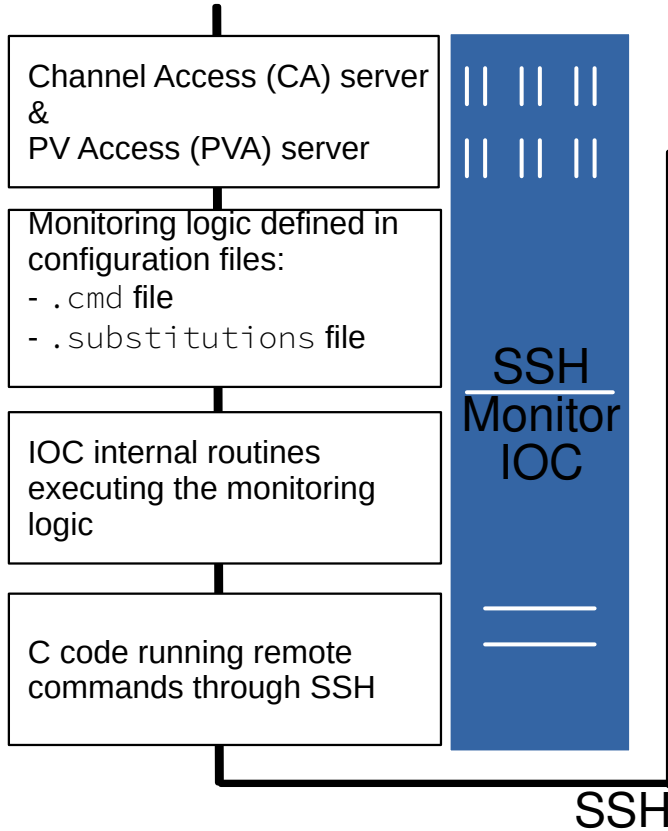

Any command you can come up with!

```
ssh -x -i $HOME/.ssh/ssh_monitor_rsa_key monitor-user@192.168.1.2 \  
"df -h / | awk '{print \%5}' | tail -1 | tr -d '%%'" # get % of used space on root part  
ssh -x -i $HOME/.ssh/ssh_monitor_rsa_key monitor-user@192.168.1.2 \  
"df -i / | awk '{print \%5}' | tail -1 | tr -d '%%'" # get % of used inodes on root part  
ssh -x -i $HOME/.ssh/ssh_monitor_rsa_key monitor-user@192.168.1.2 \  
"free -tm | grep 'Mem:' | awk '{print \%7}'" # get available RAM  
ssh -x -i $HOME/.ssh/ssh_monitor_rsa_key monitor-user@192.168.1.2 \  
"uptime | rev | awk '{print \%1}' | rev" # get proc(s) load  
# ... and a lot more!
```

Note : an SSH command is just a regular shell command, executed through SSH

Security implications



SSH communication is encrypted.

OK.

But this is not enough.

See the [security guide in the SSH Monitor documentation](#)

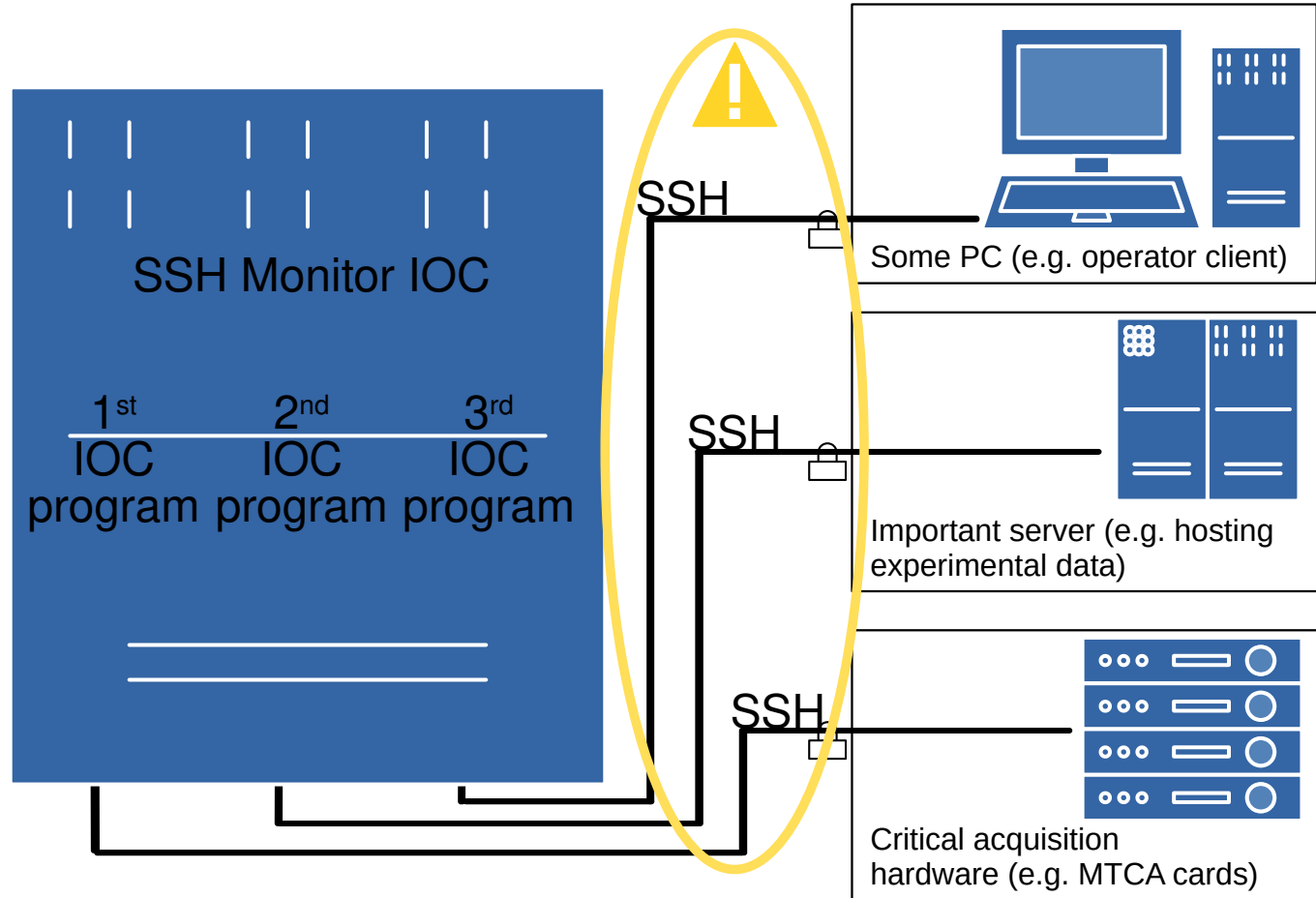

Nice features



- SSH `-J` jump option
- SSH mutualized connexions
- SSH configuration like described by `man ssh`
- Send any command you want, as long as it can run on the target
- A lot of common commands are already included as examples
- SSH Monitor includes a very complete CI that run a lot of tests (including security checks!)

Carefully crafted documentation (with Diátaxis)



See here: <https://sshmonitor-26ef1e.gitlab.io>

The screenshot shows the SSH Monitor homepage. It features a large logo on the left, a search bar, and a navigation menu with categories like SSH Monitor, Glossary, Tutorials, and How-to guides. The main content area is titled 'Introduction' and contains text about the tool's capabilities and usage.

The screenshot shows the 'Glossary' page, which lists terms like 'SSH Monitor', 'Tutorials', 'How-to guides', 'Explanations', 'References', 'Troubleshooting guide', 'Contribution guide', 'Project layout', 'Change log', and 'Similar work / Alternatives'. The 'Step-by-step tutorial on a Rocky Linux VM' is highlighted.

The screenshot shows the 'Step-by-step tutorial on a Rocky Linux VM' page. It includes a search bar, a navigation menu, and the main content area with the title '1. How to install, update and remove SSH Monitor' and a sub-section '1.1. How to install'. The prerequisites section lists tools like Gawk, lputils, Openssh, and EPICS base.

- 1.1. How to install
- 1.2. How to update
- 1.3. How to remove

Get the most of it with HMI, archiving, and alarms

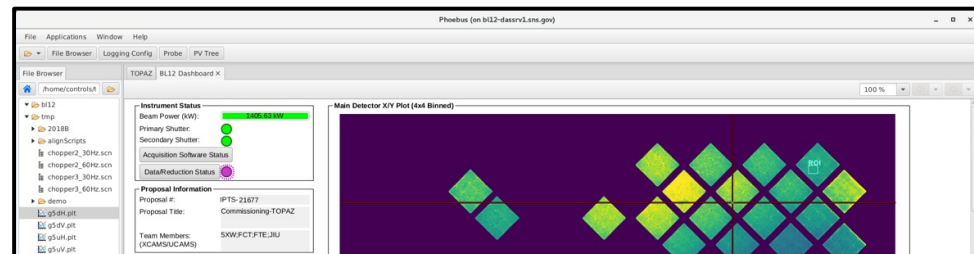
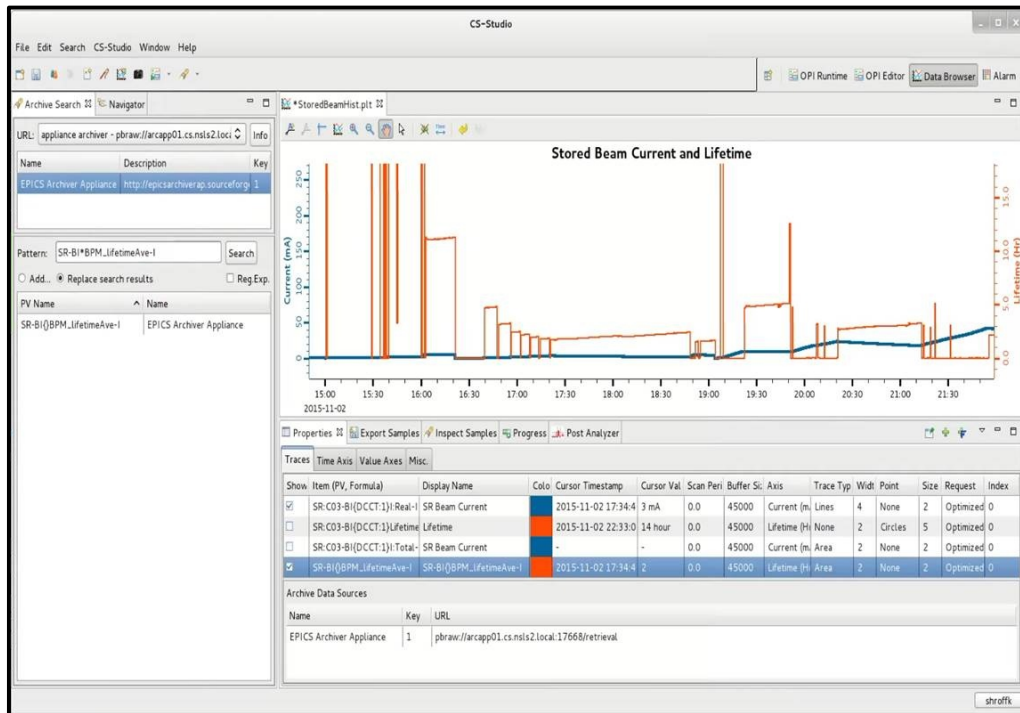

Description	Alarm Severity	Alarm Status	Alarm Time	Alarm Value	PV Severity	PV S
urrent of the BP signal as measured by the MC	MINOR	LOW_ALARM	2023-08-30 09:45:02.170	0.0	OK	NO_ALAR
of the MAIN Supply after the power supply control...	MAJOR	LOLO_ALARM	2023-09-01 03:50:59.165	0.0	OK	NO_ALAR
of the STANDBY Supply after the power switching	MAJOR	LOLO_ALARM	2023-09-01 03:50:59.165	0.0	OK	NO_ALAR
ture measured below heat sink next to Zynq chip	MINOR	LOW_ALARM	2023-09-01 03:50:59.139	0.0	OK	NO_ALAR
humidity	MINOR	LOW_ALARM	2023-09-01 03:50:59.165	0.0	OK	NO_ALAR
ver Supply, Power Good	MAJOR	STATE_ALARM	2023-09-01 03:50:59.165	0.0	OK	NO_ALAR
ver Supply, Not Alert	MAJOR	STATE_ALARM	2023-09-01 03:50:59.165	0.0	OK	NO_ALAR
ture measured with humidity sensor	MINOR	LOW_ALARM	2023-09-01 03:50:59.165	0.0	OK	NO_ALAR
ture measured by fan controller	UNDEFINED	Disconnected	2023-06-29 02:07:28.336	0.0	MINOR	LOW_ALA
ture measured by fan controller	UNDEFINED	Disconnected	2023-06-29 02:07:17.061	0.0	MINOR	LOW_ALA
Fan A in rpm	UNDEFINED	Disconnected	2023-06-29 02:07:17.061	0.0	OK	NO_ALAR
Fan A in rpm	UNDEFINED	Disconnected	2023-06-29 02:07:28.336	0.0	OK	NO_ALAR
of the MAIN Supply before the power supply contr...	UNDEFINED	Disconnected	2023-06-29 02:07:17.062	0.0	OK	NO_ALAR
of the MAIN Supply after the power supply control...	UNDEFINED	Disconnected	2023-06-29 02:07:28.336	0.0	MAJOR	LOLO_AL
ture lower PCB edge	UNDEFINED	Disconnected	2023-06-29 02:07:28.336	0.0	MINOR	LOW_ALA
oltage of the STANDBY Supply after the power switching	UNDEFINED	Disconnected	2023-06-29 02:07:17.061	0.0	MAJOR	LOLO_AL

Acknowledged Alarms: 78

PV	Description	Alarm Severity	Alarm Status	Alarm Time	Alarm Value	PV Severity	PV S
FBIS-SCU01:Ctrl-MC-01:BP_I_A	Input current of the BP signal as measured by the MC	MINOR_ACK	LOW_ALARM	2023-08-27 02:04:32.162	0.0	MINOR	LOW_ALA
FBIS-SCU01:Ctrl-MC-01:Red_BP_I_A	Input current of the redundant BP signal as measured by ...	MINOR_ACK	LOW_ALARM	2023-08-27 02:04:32.162	0.0	MINOR	LOW_ALA
FBIS-SCU01:Ctrl-MC-02:IntV_A	Voltage of the MAIN Supply after the power supply control...	MAJOR_ACK	LOLO_ALARM	2023-08-27 02:04:32.164	0.0	MAJOR	LOLO_AL
FBIS-SCU01:Ctrl-MC-02:V1V8_A	Voltage of the MC internal 1V8 supply	MAJOR_ACK	LOLO_ALARM	2023-08-27 02:04:32.164	0.0	MAJOR	LOLO_AL
FBIS-SCU01:Ctrl-MC-02:V3V3_A	Voltage of the MC internal 3V3 supply	MAJOR_ACK	LOLO_ALARM	2023-08-27 02:04:32.164	0.0	MAJOR	LOLO_AL
FBIS-SCU01:Ctrl-MC-03:BP_I_A	Input current of the BP signal as measured by the MC	MINOR_ACK	LOW_ALARM	2023-08-27 02:04:32.167	0.0	MINOR	LOW_ALA

Some real-world use case example

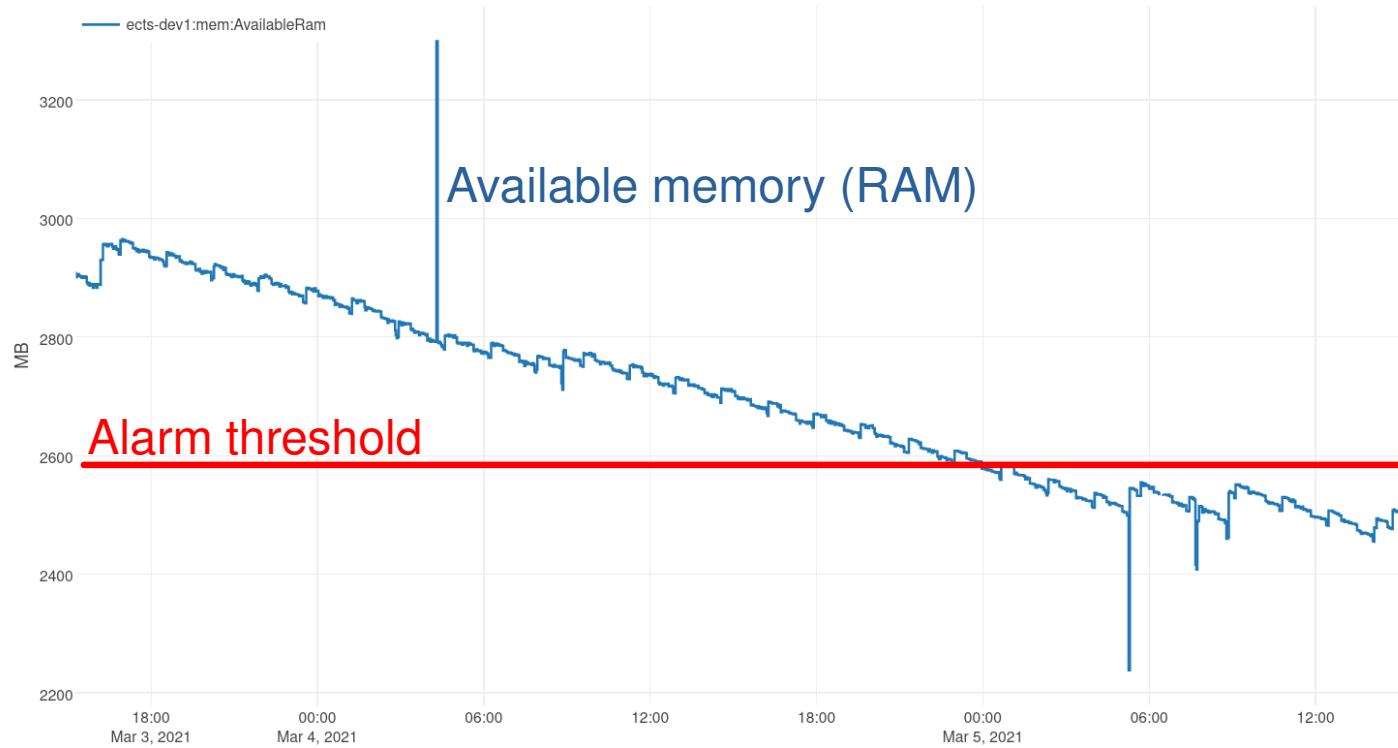

Limitations



```
ssh -x -i $HOME/.ssh/ssh_monitor_rsa_key monitor-user@192.168.1.2 \  
"df -h / | awk '{print \$5}' | tail -1 | tr -d '%%' # get % of used space on root part  
  
ssh -x -i $HOME/.ssh/ssh_monitor_rsa_key monitor-user@192.168.1.2 \  
"df -i / | awk '{print \$5}' | tail -1 | tr -d '%%' # get % of used inodes on root part  
  
ssh -x -i $HOME/.ssh/ssh_monitor_rsa_key monitor-user@192.168.1.2 \  
"free -tm | grep 'Mem:' | awk '{print \$7}'" # get available RAM  
  
ssh -x -i $HOME/.ssh/ssh_monitor_rsa_key monitor-user@192.168.1.2 \  
"uptime | rev | awk '{print \$1}' | rev" # get proc(s) load  
  
# ... and a lot more!
```



```
# scalar instruction 1:  
#-----  
# the result of this instruction will be stored in  
# the record called "${PREFIX}${CATEGORY}${PV_NAME_SCALAR_1}"  
#  
PV_NAME_SCALAR_1 = "scalar1"  
SCALAR_1_INSTRUCTION = "echo 1 #LOCAL" # Note that `#LOCAL` specifies that the instruction  
# run on the host rather than the target  
  
LOAD_SCALAR_1 = ""  
SCALAR_1_INSTRUCTION_LENGTH = "16" # specify the number of characters used  
# in ${SCALAR_1_INSTRUCTION} (default is 1024)  
# this is optional if length is less than 1024  
  
# scalar instruction 2:  
#-----  
# the result of this instruction will be stored in  
# the record called '${PREFIX}${CATEGORY}${PV_NAME_SCALAR_2}'  
#  
PV_NAME_SCALAR_2 = "ping_test"  
SCALAR_2_INSTRUCTION = "ping -c 3 192.168.1.2 | grep -q '3 packets transmitted, 3 received, ("  
PREC_SCALAR_2 = "0"  
LOAD_SCALAR_2 = ""  
# if ${SCALAR_2_INSTRUCTION} > 0 then MAJOR alarm:  
HIHI_SCALAR_2 = "1"  
LOAD_HIHI_SCALAR_2 = ""  
HHSV_SCALAR_2 = "MAJOR"  
LOAD_HHSV_SCALAR_2 = ""  
# if ${SCALAR_2_INSTRUCTION} < 0 then MAJOR alarm:  
LOLO_SCALAR_2 = "-1"  
LOAD_LOLO_SCALAR_2 = ""  
LLSV_SCALAR_2 = "MAJOR"  
LOAD_LLSV_SCALAR_2 = ""  
# (if ${SCALAR_2_INSTRUCTION} == 0 then no alarm)
```

Why and why not SSH Monitor



Why not Grafana + Prometheus?



Roadmap



📄 Add support for IOC Shell log monitoring

sshmonitor/sshmonitor#39 · created Jul 8, 2021, 2:57 PM by Stéphane Tzvetkov
◇ v2.3.0 enhancement

updated Apr 18, 2024, 2:33 PM 🗨️ 1

📄 Add support for Windows targets

sshmonitor/sshmonitor#38 · created Mar 18, 2021, 11:31 AM by Stéphane Tzvetkov
◇ v2.3.0 enhancement

updated Apr 18, 2024, 2:34 PM 🗨️ 1

📄 Add support for disk I/O monitoring

sshmonitor/sshmonitor#31 · created Mar 5, 2021, 11:47 AM by Stéphane Tzvetkov
◇ v2.3.0 enhancement

updated Apr 18, 2024, 2:35 PM

📄 Add support for network monitoring

sshmonitor/sshmonitor#30 · created Mar 5, 2021, 11:41 AM by Stéphane Tzvetkov
◇ v2.3.0 enhancement

updated Apr 18, 2024, 2:36 PM

📄 Add synching monitoring

sshmonitor/sshmonitor#26 · created Feb 17, 2021, 9:33 AM by Stéphane Tzvetkov
enhancement

updated May 17, 2021, 9:43 AM 🗨️ 4

📄 Add disks health supervision support with SMART

sshmonitor/sshmonitor#7 · created Dec 2, 2020, 9:17 AM by Stéphane Tzvetkov
◇ v2.3.0 enhancement warning

updated Jun 13, 2024, 5:17 PM 🗨️ 4

📄 Add logs supervision support

sshmonitor/sshmonitor#6 · created Dec 2, 2020, 9:17 AM by Stéphane Tzvetkov
◇ v2.3.0 enhancement

updated Oct 15, 2024, 3:02 PM 👤 1

📄 Add temperature supervision support

sshmonitor/sshmonitor#5 · created Dec 2, 2020, 9:16 AM by Stéphane Tzvetkov
enhancement

updated Apr 6, 2021, 4:14 PM 🗨️ 1

📄 Add RAID supervision support

sshmonitor/sshmonitor#2 · created Dec 2, 2020, 9:15 AM by Stéphane Tzvetkov
enhancement

updated Apr 6, 2021, 4:14 PM 🗨️ 2

📄 Add elasticsearch support

sshmonitor/sshmonitor#71 · created Jul 4, 2023, 3:18 PM by Stéphane Tzvetkov
◇ v2.3.0 enhancement

updated Oct 15, 2024, 3:00 PM 👤 1

📄 Add channelfinder monitoring support

sshmonitor/sshmonitor#70 · created Jul 4, 2023, 2:48 PM by Stéphane Tzvetkov
◇ v2.3.0 enhancement

updated Oct 15, 2024, 3:00 PM 🗨️ 1

📄 Add SNMP support

sshmonitor/sshmonitor#58 · created Oct 25, 2022, 4:24 PM by Stéphane Tzvetkov

enhancement

📄 Add iLO support

sshmonitor/sshmonitor#57 · created Oct 25, 2022, 4:23 PM by Stéphane Tzvetkov

enhancement

📄 Add iDRAC support

sshmonitor/sshmonitor#56 · created Oct 25, 2022, 4:22 PM by Stéphane Tzvetkov
enhancement

updated Oct 25, 2022, 4:23 PM

📄 Add support for Grafana (via Prometheus?)

sshmonitor/sshmonitor#52 · created Feb 18, 2022, 11:24 AM by Stéphane Tzvetkov

updated Aug 3, 2022, 10:14 AM 🗨️ 4

📄 Add support for IPMI supervision

sshmonitor/sshmonitor#50 · created Nov 26, 2021, 11:41 AM by Stéphane Tzvetkov

enhancement 👤 1

Roadmap

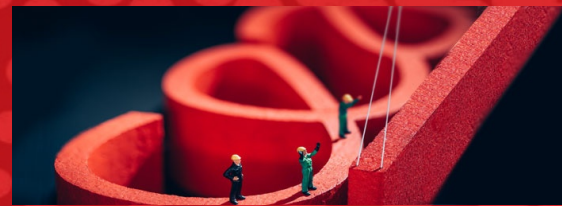

v2.2.1 5613fec8 · Merge branch 'v2.2.1' into 'master' · Apr 13, 2026, 4:01 PM 🔗 Release: v2.2.1
v2.2.0 61ccc376 · feat: improve tutorials · Oct 24, 2024, 1:25 PM 🔗 Release: v2.2.0
v2.1.2 d5f7f096 · Merge branch 'milestones_v2.1.2' into 'master' · Feb 21, 2024, 3:29 PM 🔗 Release: v2.1.2
v2.1.1 8ad4be16 · feat: update CHANGELOG.md and project_layout.md for v2.1.1 · Jan 25, 2024, 4:11 PM 🔗 Release: v2.1.1
v2.1.0 bd5e6d55 · Merge branch 'milestones_v2.1.0' into 'master' · Dec 14, 2023, 10:35 AM 🔗 Release: v2.1.0
v2.0.0 074153be · feat: finale CHANGELOG and README update before v2 · Jun 14, 2023, 11:38 AM 🔗 Release: v2.0.0
v1.0.0 592152f3 · update CHANGELOG for next tag/release v1.0.0 · Mar 15, 2021, 12:04 PM
v0.9 0d024838 · fix #29, now each IOC has its own set of caches · Mar 5, 2021, 9:24 AM
v0.8 3cfff65b · fix bad loop over string array · Jan 26, 2021, 9:59 AM
v0.7 036eae86 · update CHANGELOG for next tag/release v0.7 · Jan 21, 2021, 8:56 AM
v0.6 5157605b · update CHANGELOG for next tag/release v0.6 · Jan 15, 2021, 5:03 PM
v0.5 f63857ac · update CHANGELOG for next tag/release v0.5 · Jan 14, 2021, 3:24 PM
v0.4 080c85a5 · update CHANGELOG for next tag/release · Jan 14, 2021, 2:37 PM
v0.3 165e1f34 · update CHANGELOG for next tag/release · Jan 13, 2021, 3:25 PM
v0.2 de0c6c22 · update CHANGELOG for next tag/release · Jan 13, 2021, 9:17 AM
v0.1 69c241de · fix next tag name in CHANGELOG · Jan 11, 2021, 9:54 AM
beta e145615d · replace sub records by asub records · Dec 18, 2020, 10:14 PM
alpha 97db08f0 · remove bad spaces in README · Dec 17, 2020, 2:32 PM

v2.3.0 📦 sshmonitor / sshmonitor	Open 40%	⋮
v2.2.1 🚀 v2.2.1 📦 sshmonitor / sshmonitor	Closed 100%	⋮
v2.2.0 🚀 v2.2.0 📦 sshmonitor / sshmonitor	Closed 100%	⋮
v2.1.2 🚀 v2.1.2 📦 sshmonitor / sshmonitor	Closed 100%	⋮
v2.1.1 🚀 v2.1.1 📦 sshmonitor / sshmonitor	Closed 100%	⋮
v2.1.0 🚀 v2.1.0 📦 sshmonitor / sshmonitor	Closed 100%	⋮
v2.0.0 🚀 v2.0.0 📦 sshmonitor / sshmonitor	Closed 100%	⋮

How to get started?



- If you are looking for some step-by-step guidance: check the [tutorials](#)
- If you want to dive right into it: check the [how-to guides](#)
- If you ever run into a issue: check the [troubleshooting guide](#)
- If you feel like helping: check the [contribution guide](#)

Alternatives



I only found 3 published EPICS alternatives (but this might have changed since last time I looked):

- PCMON :
 - “A PC monitoring application that runs as an IOC program (EPICS + Linux) and monitors the available resources.”
 - <http://epics.web.psi.ch/software/pcmon/>
 - PCMON hasn't been used in this project, because you have to install it on the computer you want to monitor (no remote monitoring) and it is not as customizable as SSH Monitor.
- devlocStats
 - “Provides support for records that show the health and status of an IOC.”
 - <https://www.slac.stanford.edu/grp/ssrl/spear/epics/site/devlocStats/>
 - DevlocStats is similar to PCMON by its design: you have to install it on the target computer (no remote monitoring) and is not as customizable as SSH Monitor.
- AsynSSH
 - “A standard Asyn driver interface for message based communications using the SSH protocol.”
 - https://observatorysciences.co.uk/assets/uploads/downloads/asynSSH_EPICS_Developers_Manual_V1-0.pdf
 - AsynSSH hasn't been used either in this project, because it seems unmaintained since 31/05/2013, and because the associated documentation present it as a "draft".

Questions?

