

ANR - HINA

Highly charged Ions for Nuclear physics and Astrophysics



Polynesian Goddess of the Moon
and Stars

Journée des EAP — IN2P3
09/10/2025

Sarah Naïmi





HINA experiment @DESIR: What? Why? How?

What?

Decay highly charged light ions (EC)

Why?

Nuclear physics
Astrophysics

How?

Trap-based setup

HINA@GANIL

H-like ion	$I_i^{\pi_i} \rightarrow I_f^{\pi_f}$	μ/μ_N	δE (eV)	$\tau_{1/2}$	$T_{1/2}$
¹⁹ Ne	$\frac{1}{2}^+ \rightarrow \frac{1}{2}^+$	-1.89	0.004	3 d	17.3 s
³⁷ Ar	$\frac{3}{2}^+ \rightarrow \frac{3}{2}^+$	+1.15	0.01	10 h	35 d
⁶⁴ Cu	$1^+ \rightarrow 0^+$	-0.22	0.009	7 h	12.7 h
⁶⁸ Ga	$1^+ \rightarrow 0^+$	+0.01	0.001	5 yr	67.7 min

Cosmic Ray

EC on H-, He- & Li-like ions
Nuclear physics, CR & PNC?

Focus on light ions

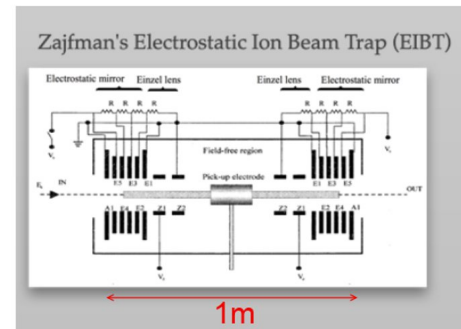
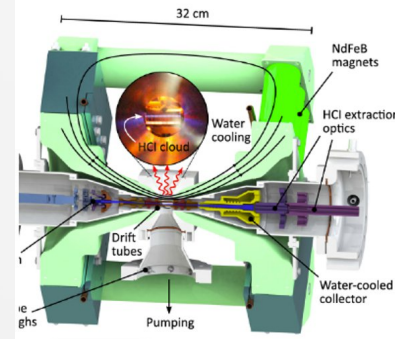



+Value ② : Expertise rare EBIT

Application Physique Atomique

Region	Institutions / Groups	Years of Operation
USA	LLNL (EBIT-I & SuperEBIT)	EBIT-I: ~1986–present SuperEBIT: ~1990s–present
USA	NIST (table-top EBIT)	Mid-1990s–present
Germany	MPIK Heidelberg (Heidelberg EBIT)	~2001–present
Germany	HZDR (Dresden EBIT)	Mid-2000s–present
Germany	Fraunhofer FEP (EBIT developments)	Mid-2010s–present
South Korea	UNIST (permanent-magnet EBIT)	~2018–present
Japan	UEC Tokyo (Tokyo EBIT)	Mid-1990s–present
Northern Ireland	Queen’s University Belfast (hybrid EBIT design)	~2000s–present

Application Physique Nucl aire!

Canada	TRIUMF–TITAN EBIT	Dec 2010–present
France	HINA-EBIT @DESIR	2030~





+Value ③ : Forte Synergie à DESIR



High precision collinear laser spectroscopy
(high sensitivity to charge radii & high precision calculation of mass shift for 2e- system)

HINA



Spectroscopy of HCIs:
Orbital EC
light ions

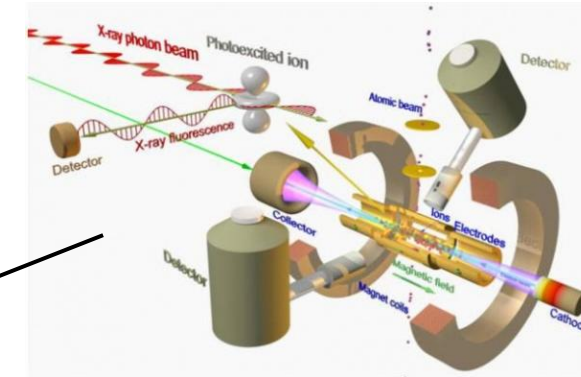

Bound b-decay
Cryo-HINA
heavy ions

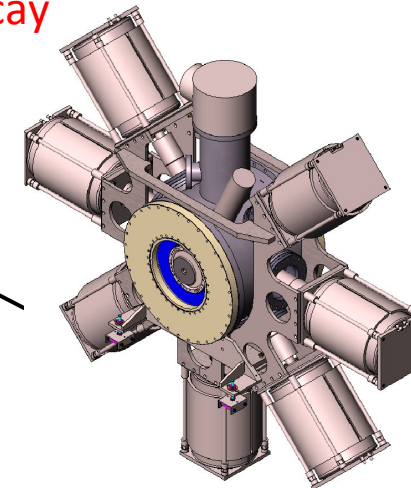

High precision mass measurements

$$\frac{m}{\Delta m} \propto \frac{q \cdot B}{m} \cdot T_{RF} \sqrt{N}$$

Absolute
charge radii

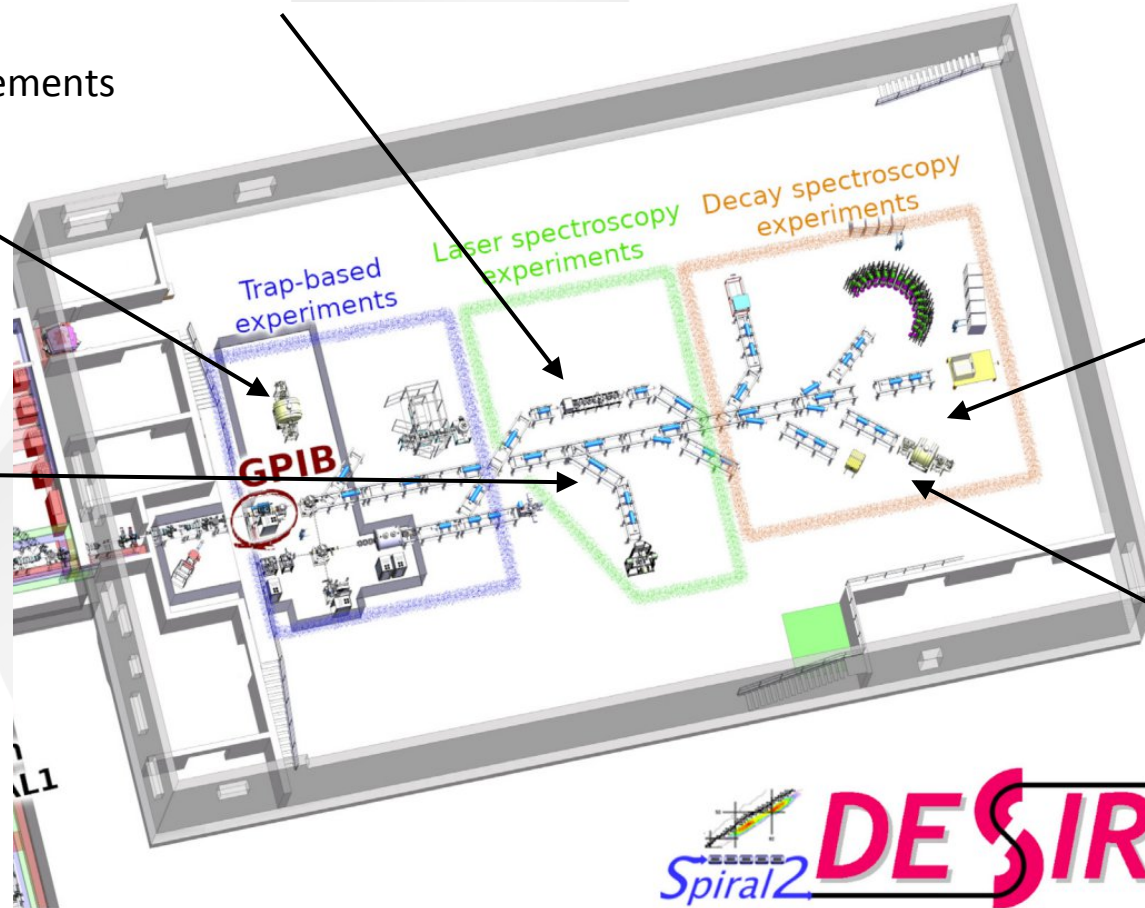
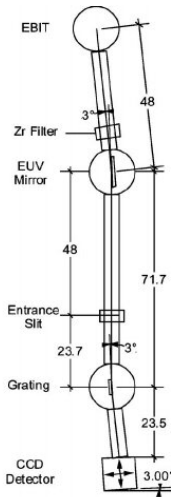

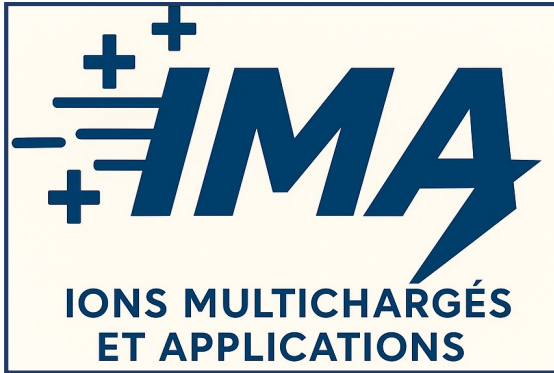

Projects	Project 1	Project 2	Project 3
Timeline	2026--29	2030--31	2032--35
	Short-term	Mid-term	Long-term
HINA-EBIT	Room temperature EBIT		Cryogenic EBIT
Funding	ANR HINA	-	-
Objective	Production/Trapping HCl _s	Coupling to DESIR	Decay of heavy HCl _s
Accessible EI	H-like up to Fe & He-like up to Xe		Bare up to Xe & He-like up to Pb

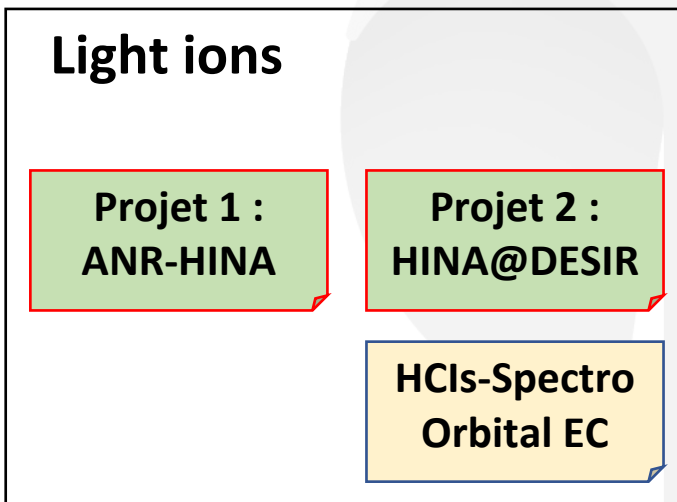

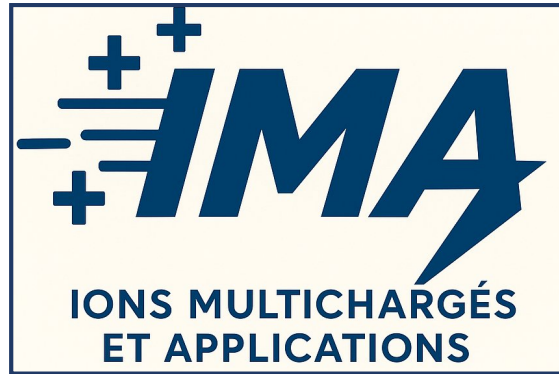

Projects	Project 1	Project 2	Project 3
Timeline	2026--29	2030--31	2032--35
	Short-term	Mid-term	Long-term
HINA-EBIT	Room temperature EBIT		Cryogenic EBIT
Funding	ANR HINA	-	-
Objective	Production/Trapping HCl _s	Coupling to DESIR	Decay of heavy HCl _s
Accessible EI	H-like up to Fe & He-like up to Xe		Bare up to Xe & He-like up to Pb

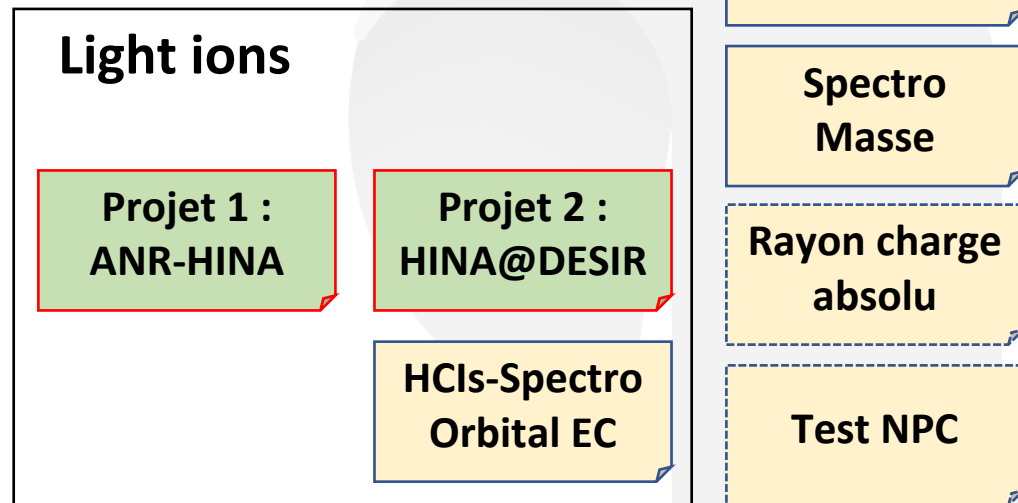

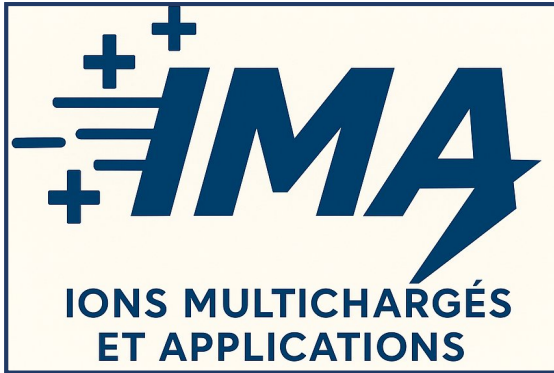

Projects	Project 1	Project 2	Project 3
Timeline	2026--29	2030--31	2032--35
	Short-term	Mid-term	Long-term
HINA-EBIT	Room temperature EBIT		Cryogenic EBIT
Funding	ANR HINA	-	-
Objective	Production/Trapping HCIs	Coupling to DESIR	Decay of heavy HCIs
Accessible EI	H-like up to Fe & He-like up to Xe		Bare up to Xe & He-like up to Pb

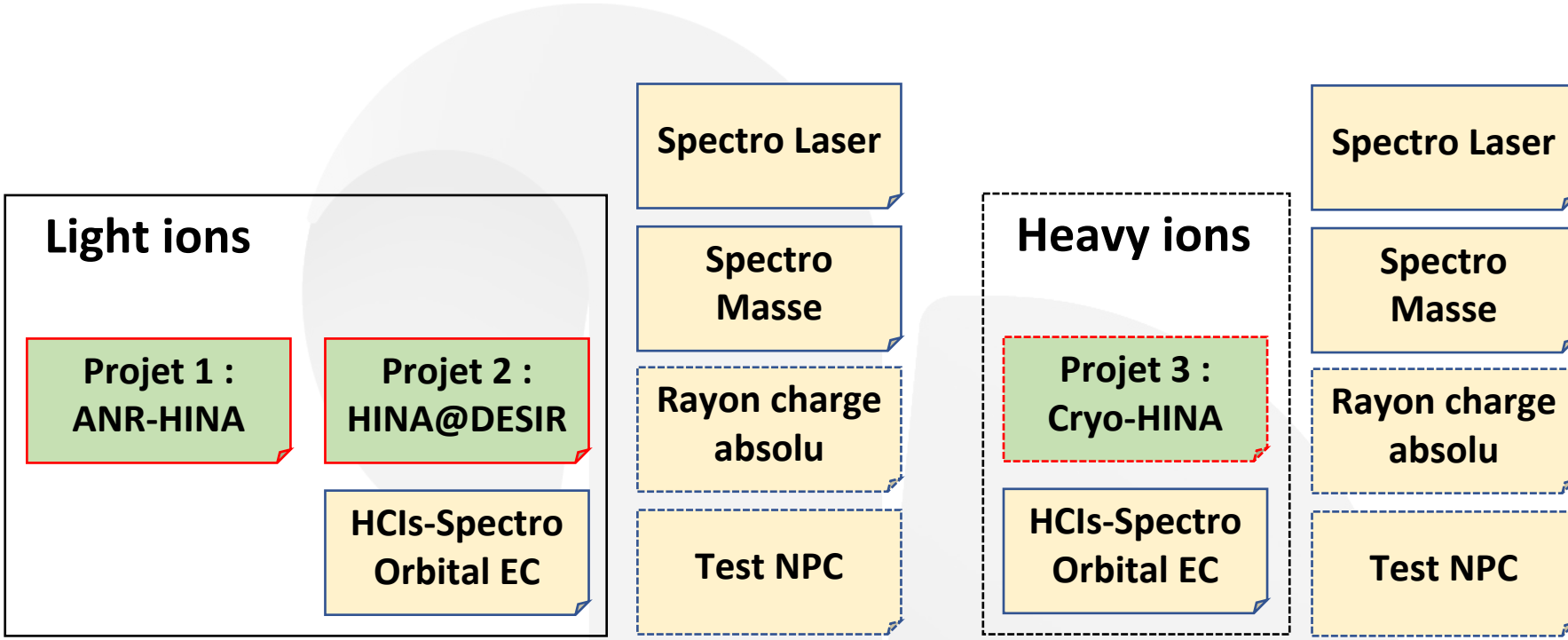

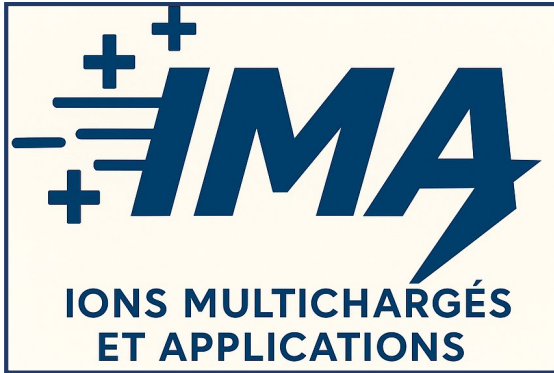

Pojects	Project 1	Project 2	Project 3
Timeline	2026--29	2030--31	2032--35
	Short-term	Mid-term	Long-term
HINA-EBIT	Room temperature EBIT		Cryogenic EBIT
Funding	ANR HINA	-	-
Objective	Production/Trapping HCIs	Coupling to DESIR	Decay of heavy HCIs
Accessible EI	H-like up to Fe & He-like up to Xe		Bare up to Xe & He-like up to Pb

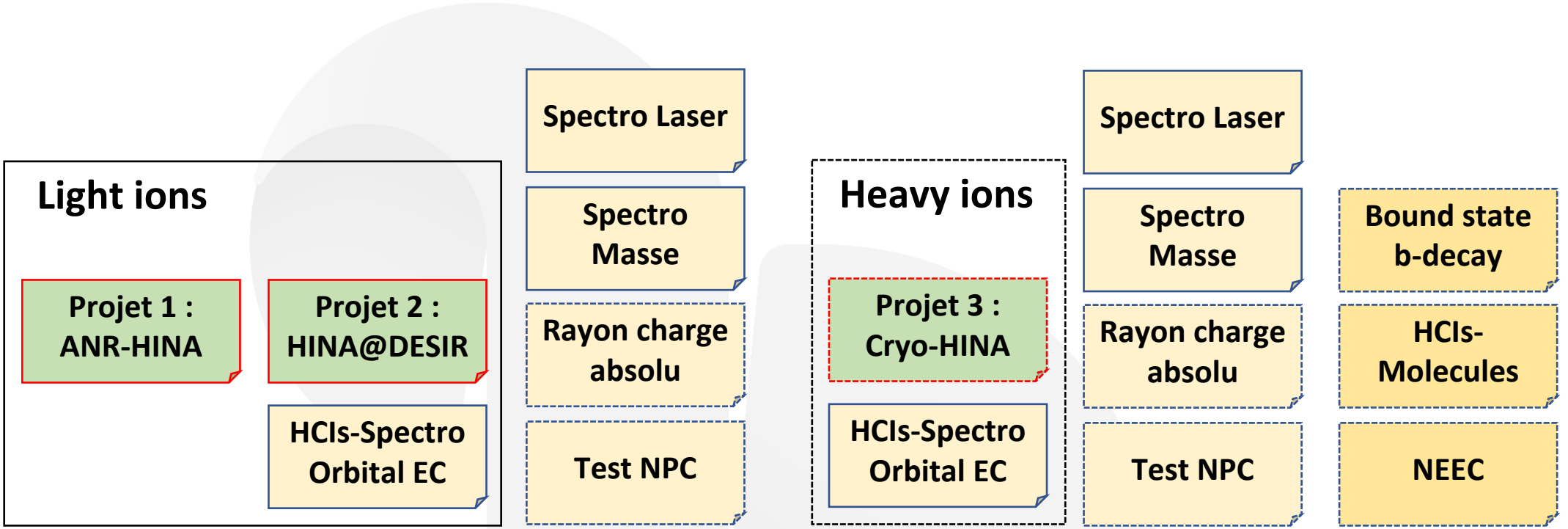

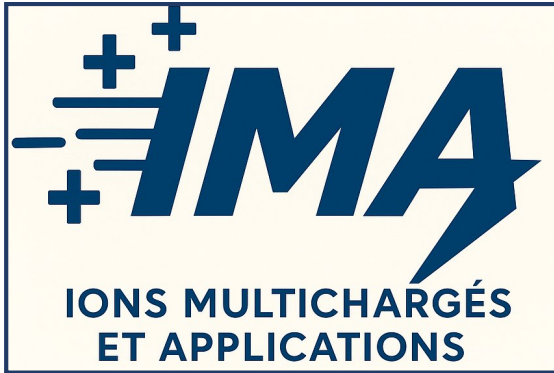

Pojects	Project 1	Project 2	Project 3
Timeline	2026--29	2030--31	2032--35
	Short-term	Mid-term	Long-term
HINA-EBIT	Room temperature EBIT		Cryogenic EBIT
Funding	ANR HINA	-	-
Objective	Production/Trapping HCl _s	Coupling to DESIR	Decay of heavy HCl _s
Accessible EI	H-like up to Fe & He-like up to Xe		Bare up to Xe & He-like up to Pb



Projet scientifique fédérateur collaboratif

Light ions

Projet 1 : ANR-HINA

Projet 2 : HINA@DESIR

HCl_s-Spectro Orbital EC

Spectro Laser

Spectro Masse

Rayon charge absolu

Test NPC

Heavy ions

Projet 3 : Cryo-HINA

HCl_s-Spectro Orbital EC

Spectro Laser

Spectro Masse

Rayon charge absolu

Test NPC

Bound state b-decay

HCl_s-Molecules

NEEC



Preliminary HINA beamline @DESIR

Pre-ANR

ANR Timeline 2025-2029

Post-ANR

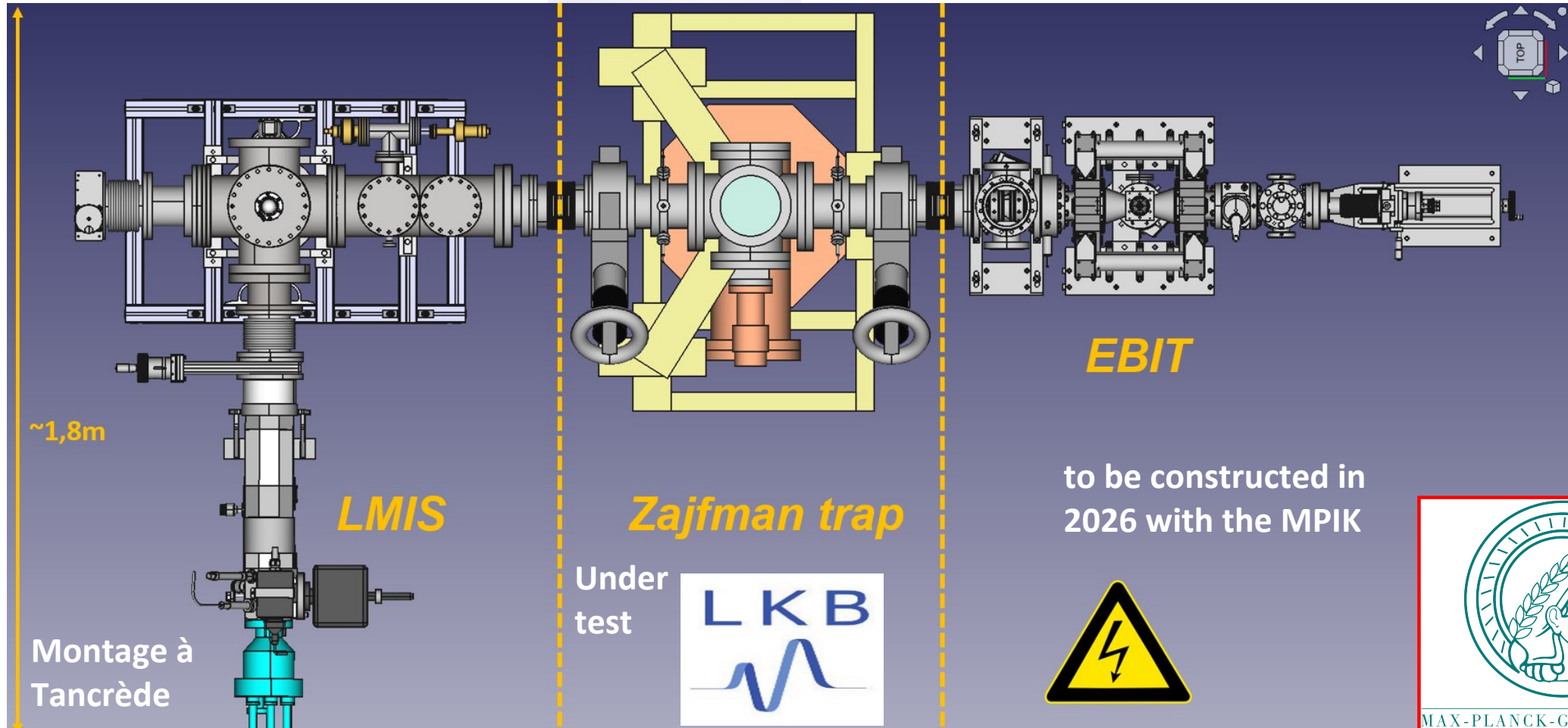
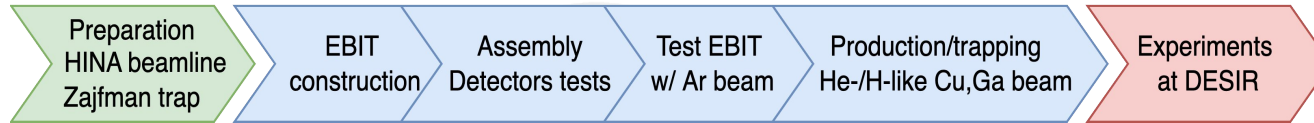



Emplacement idéal à DESIR

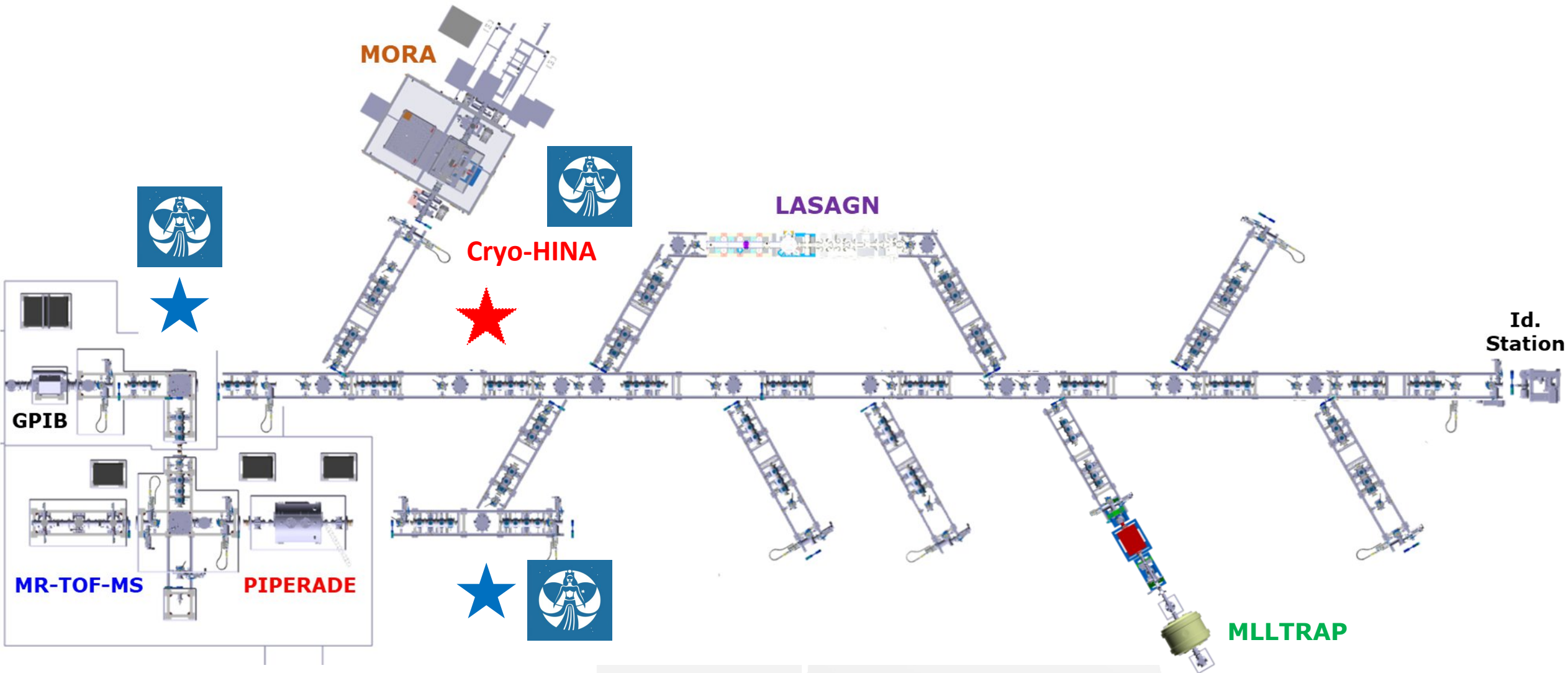



Demande de moyens

	2026	2027	2028	2029	Total
Equipements	30 000 €	- €	- €	- €	30 000 €
Electronique Zajfman	20 000 €				
Plateforme HT	10 000 €	-	- €	- €	
Fonctionnement	- €	- €	- €	- €	- €
Missions	- €	- €	- €	3 000 €	3 000 €
missions DESIR/GANIL	- €			3 000 €	
Personnels	2 000 €	2 000 €	2 000 €	2 000 €	8 000 €
stages	2 000 €	2 000 €	2 000 €	2 000 €	
TOTAL	32 000 €	2 000 €	2 000 €	5 000 €	41 000 €

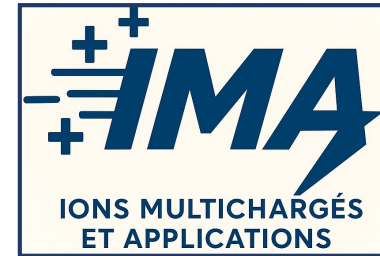

Nouveau projet scientifique fédérateur

Nom des personnes	Status	2026	2027	2028	2029	Total (FTE)
Pole Nucléaire		290%	370%	270%	230%	11,6
S. Naimi	DR	90%	90%	90%	90%	
K. Hauschild	CR	5%	10%	10%	10%	
V. Manea	CR	10%	10%	10%	10%	
M. Benhatchi	Doctorant	35%	0%	0%	0%	
ANR	Post Doc	100%	100%	0%	0%	
ANR	Doctorant	25%	100%	100%	75%	
IN2P3 (IRL NPAT)	Doctorant	15%	50%	50%	35%	
S. Della Negra	Emérite	10%	10%	10%	10%	
TOTAL (FTE)		2,90	3,70	2,70	2,30	11,60

Nom des personnes	Status	2026	2027	2028	2029	Total (FTE)
Pole Accélérateur		10%	10%	10%	10%	0,40
B. Mercier	IR	10%	10%	10%	10%	
E. Ramiraz	IR	10%	10%	10%	10%	
Pole Nucléaire		25%	20%	110%	110%	2,65
I. Ribaud	IR	25%	20%	10%	10%	
IN2P3	IR	0%	0%	100%	100%	
Plateforme MOSAIC		20%	20%	5%	5%	0,50
F. Daubisse	AI	20%	20%	5%	5%	
Pole Ingénierie		80%	50%	0%	0%	1,30
A. Migayron	AI	50%	20%	0%	0%	
D. REYNET	IR	5%	5%	0%	0%	
J. Maalmi	IR	10%	10%	0%	0%	
D. Breton	IR	5%	5%	0%	0%	
Ph. Gauron	IR	10%	10%	0%	0%	
TOTAL (FTE)		1,35	1,00	1,25	1,25	4,85

HINA@DESIR



Orbital EC in H-He-Li-like

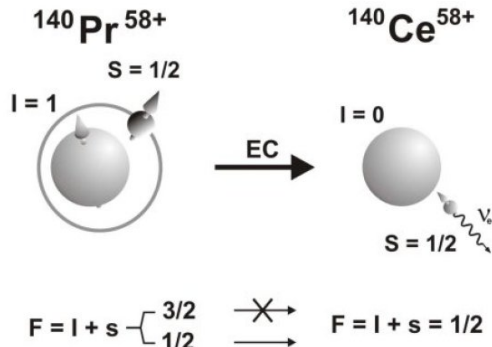

available @DESIR

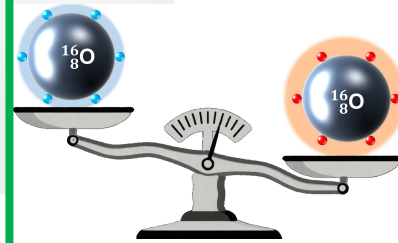

High precision Coll. laser spectro

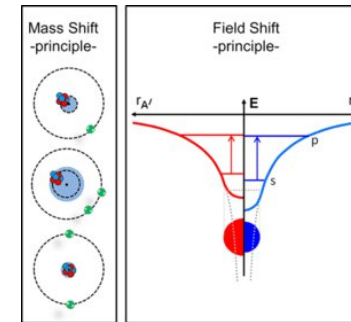

HCl's molecular actinides

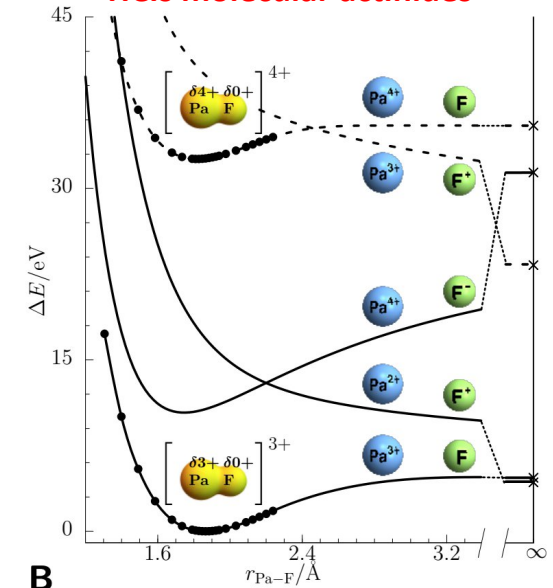

PNC test

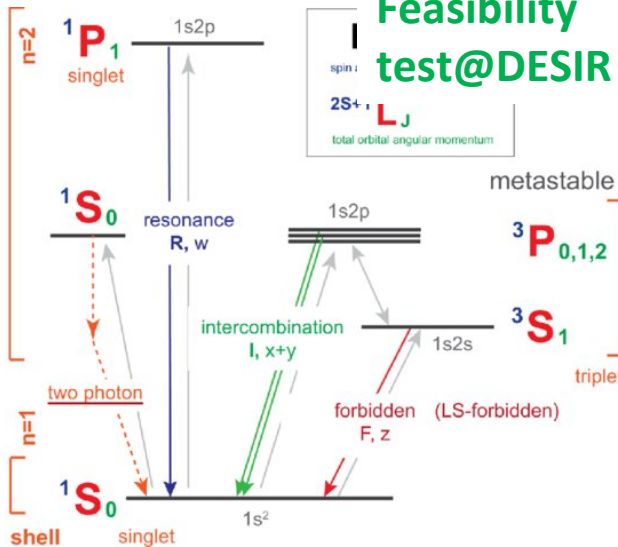

Absolute charge radii

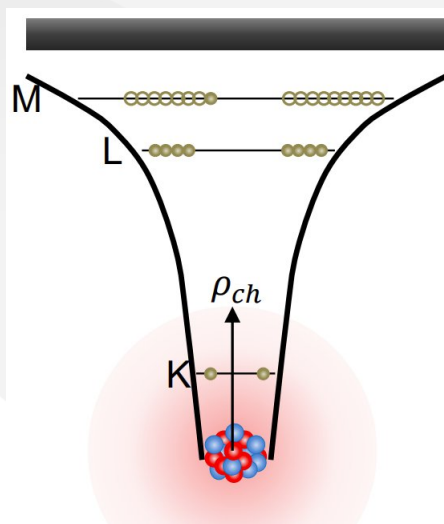

NEEC & nuclear energy

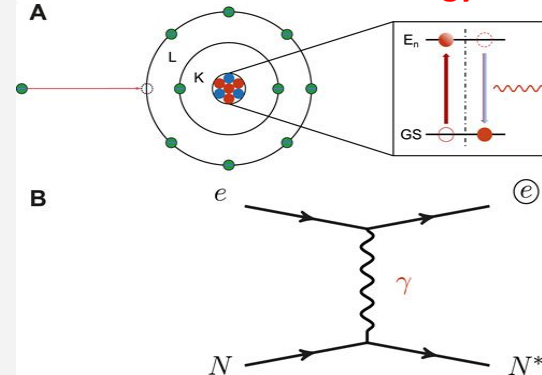

nuclear battery?



Bound state beta decay

β decay: $n \rightarrow p + e + \bar{\nu}$

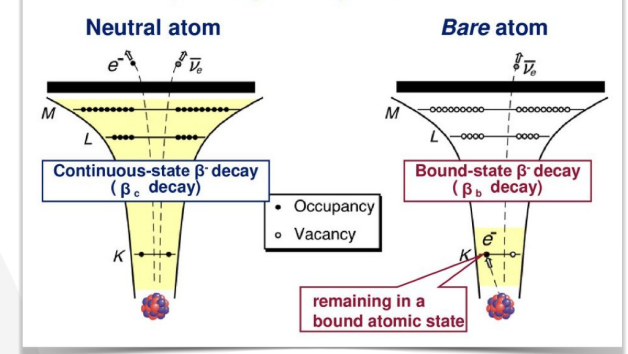



Backup



Orbital EC in H-like & He-like ions

HINA@DESIR

Suggested nuclei to be studied experimentally

H-like ion	$I_i^{\pi_i} \rightarrow I_f^{\pi_f}$	μ/μ_N	δE (eV)	$\tau_{1/2}$	$T_{1/2}$
^{19}Ne	$\frac{1}{2}^+ \rightarrow \frac{1}{2}^+$	-1.89	0.004	3 d	17.3 s
^{37}Ar	$\frac{3}{2}^+ \rightarrow \frac{3}{2}^+$	+1.15	0.01	10 h	35 d
^{64}Cu	$1^+ \rightarrow 0^+$	-0.22	0.009	7 h	12.7 h
^{68}Ga	$1^+ \rightarrow 0^+$	+0.01	0.001	5 yr	67.7 min
^{71}Ge	$\frac{1}{2}^- \rightarrow \frac{3}{2}^-$	+0.55	0.041	12 min	11.2 d
^{108}Ag	$1^+ \rightarrow 0^+$	+2.69	0.53	0.24 s	2.37 min
^{131}Cs	$\frac{5}{2}^+ \rightarrow \frac{3}{2}^+$	+3.54	0.98	31 ms	9.69 d
^{141}Nd	$\frac{3}{2}^+ \rightarrow \frac{5}{2}^+$	+1.01	0.43	0.4 s	2.5 h
^{178}Ta	$1^+ \rightarrow 0^+$	+2.74	2.87	1.6 ms	9.31 min

Cosmic Ray

Decay by EC is not allowed!

a)

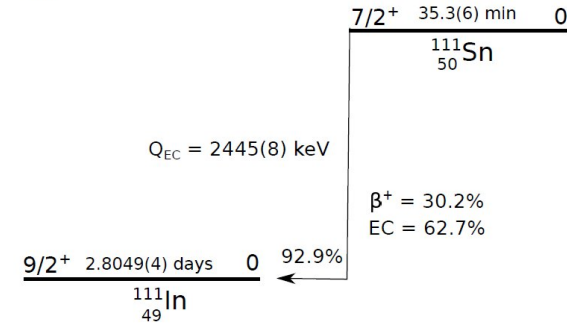

b)

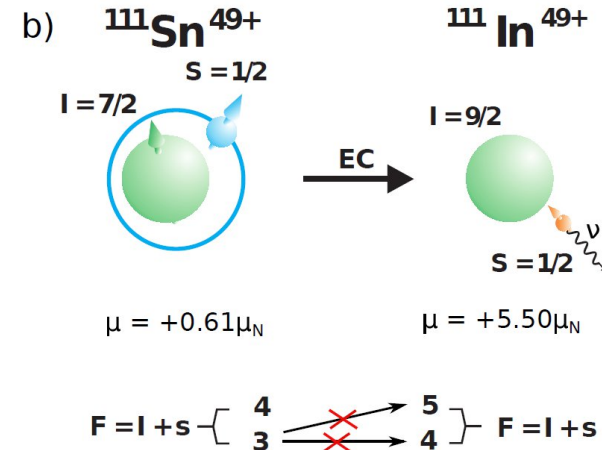

$^{64}\text{Cu}^{28+}$ 44%EC $^{64}\text{Ni}^{28+}$

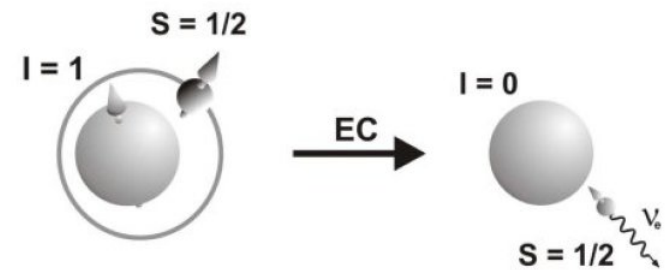

$$F^\pm = I \pm \frac{1}{2}$$

$\mu > 0$



$\mu < 0$



$\mu < 0$

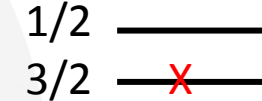

$F=1/2$

Standard theory of EC:
overlap of nuclear & electron
wave functions



PHYSICAL REVIEW C **84**, 064309 (2011)

Nuclear electron capture in Li-like ions

Katarzyna Siegień-Iwaniuk and Zygmunt Patyk

National Centre for Nuclear Research, Hoża 69, PL-00-681 Warsaw, Poland

For allowed EC $I \rightarrow I \pm 1$

$$\frac{P_0}{P_1} = \frac{2I + 1}{2(I \pm 1) + 1}$$

TABLE I. The ratio of probabilities P_0/P_1 that the lithium-like ion decays into the excited states 2^1S_0 and 2^3S_1 of the helium-like ion. The ratio is calculated for two types of EC decays $I \rightarrow I \pm 1$.

I_i	$\frac{P_0}{P_1}$ $I \rightarrow I - 1$	$\frac{P_0}{P_1}$ $I \rightarrow I + 1$
0		$\frac{1}{3}$
$\frac{1}{2}$		$\frac{1}{2}$
1	3	$\frac{3}{5}$
$\frac{3}{2}$	2	$\frac{2}{3}$
...
∞	1	1

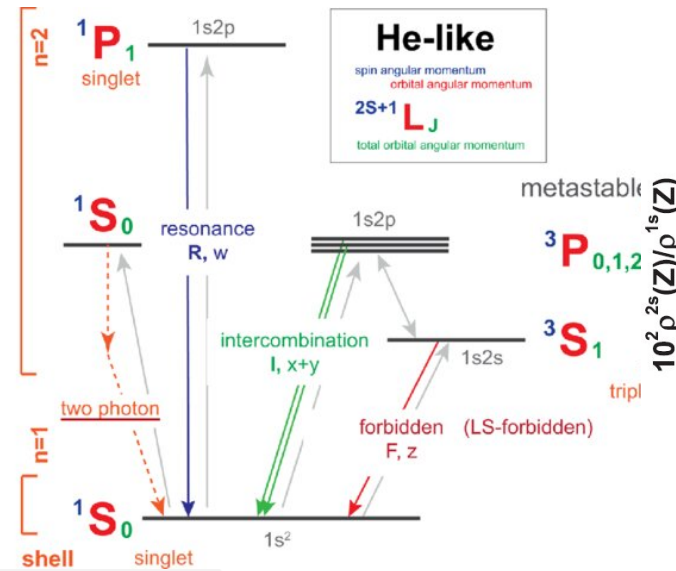

Decay of the 1^1S_0 can be very accurately calculated (QED) --> Suggested for PNC test

H-like ion	$I_i^{\pi_i} \rightarrow I_f^{\pi_f}$
^{19}Ne	$\frac{1}{2}^+ \rightarrow \frac{1}{2}^+$
^{37}Ar	$\frac{3}{2}^+ \rightarrow \frac{3}{2}^+$
^{64}Cu	$1^+ \rightarrow 0^+$
^{68}Ga	$1^+ \rightarrow 0^+$

HINA

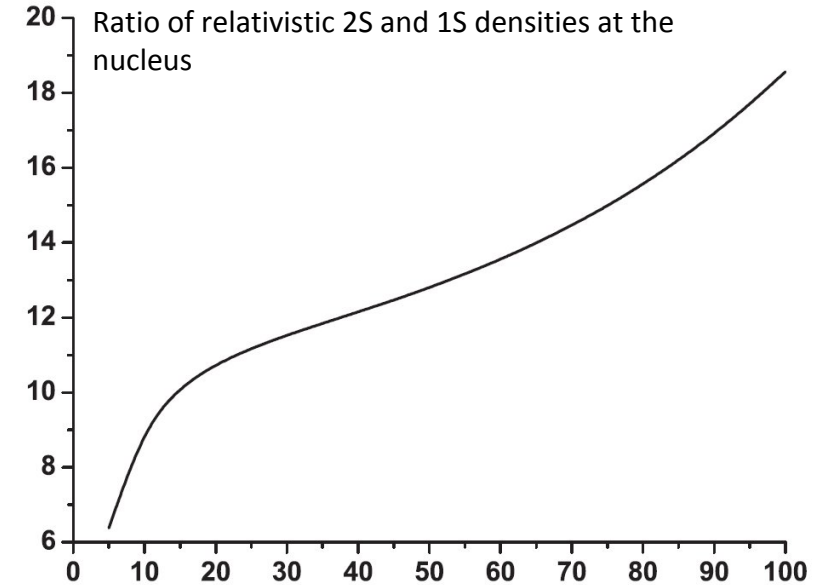
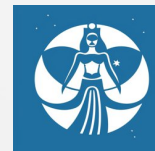

$$P_{\text{Li}} = \left(\frac{2(I \pm 1/2) + 1}{(2I + 1)} + \frac{\rho^{2s}(Z)}{2\rho^{1s}(Z)} \right) \left(1 - \frac{q}{Z} \right)^3 P_{\text{H}}$$

For allowed EC $I \rightarrow I \pm 1$

Conservation of angular momentum

Li-like ions decaying from state $I \pm \frac{1}{2}$

$$P'_{\text{Li}} = \frac{2(I \pm 1/2) + 1}{(2I + 1)} \left(1 - \frac{q}{Z} \right)^3 P_{\text{H}}$$



Mesure rayons de charge absolu (sans laser!)



Michele Sguazzin
Projet scientifique
@DESIR

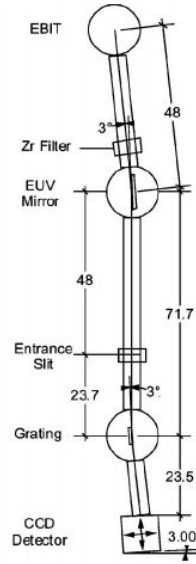
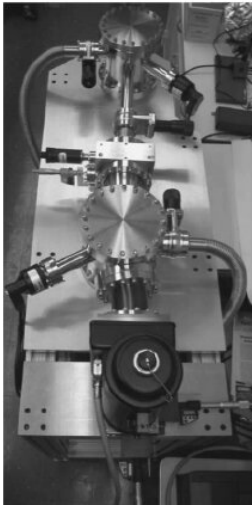

PHYSICAL REVIEW RESEARCH 7, L012024 (2025)

Letter

Determination of nuclear charge radius by extreme-ultraviolet spectroscopy of Na-like ions

A. Hosier ^{1,2,*}, Dipti ², S. A. Blundell, ³ A. Lapierre ⁴, R. Silwal, ⁵ G. Gwinner ⁶, J. N. Tan ⁷, A. Naing, ² J. D. Gillaspay ^{2,7}, Y. Yang ^{1,2}, P. Szypryt ⁸, G. O'Neil ⁸, H. Staiger ^{1,2}, J. M. Dreiling, ² A. C. C. Villari, ⁴ I. Angeli ⁹, Yu. Ralchenko ² and E. Takacs ^{1,2,†}

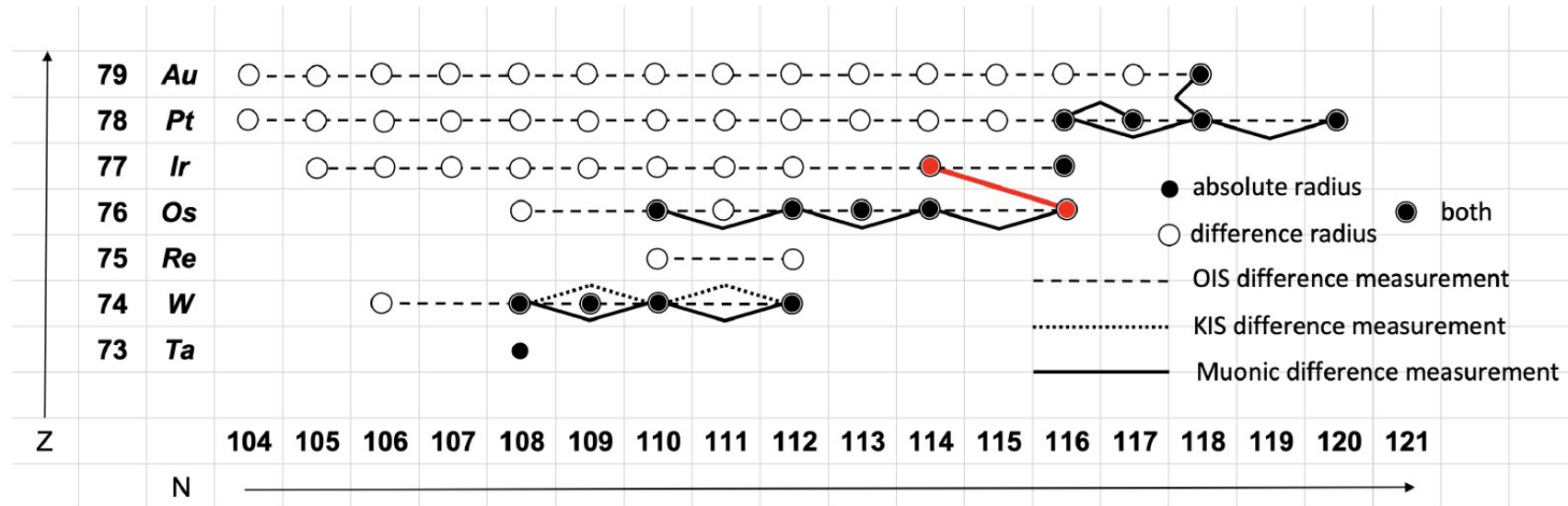

Réduction de l'incertitude dans ¹⁹¹Ir par un facteur 8
—> Répercute sur toute la chaîne isotopique de Ir



EBIT: Electron Beam Ion Trap

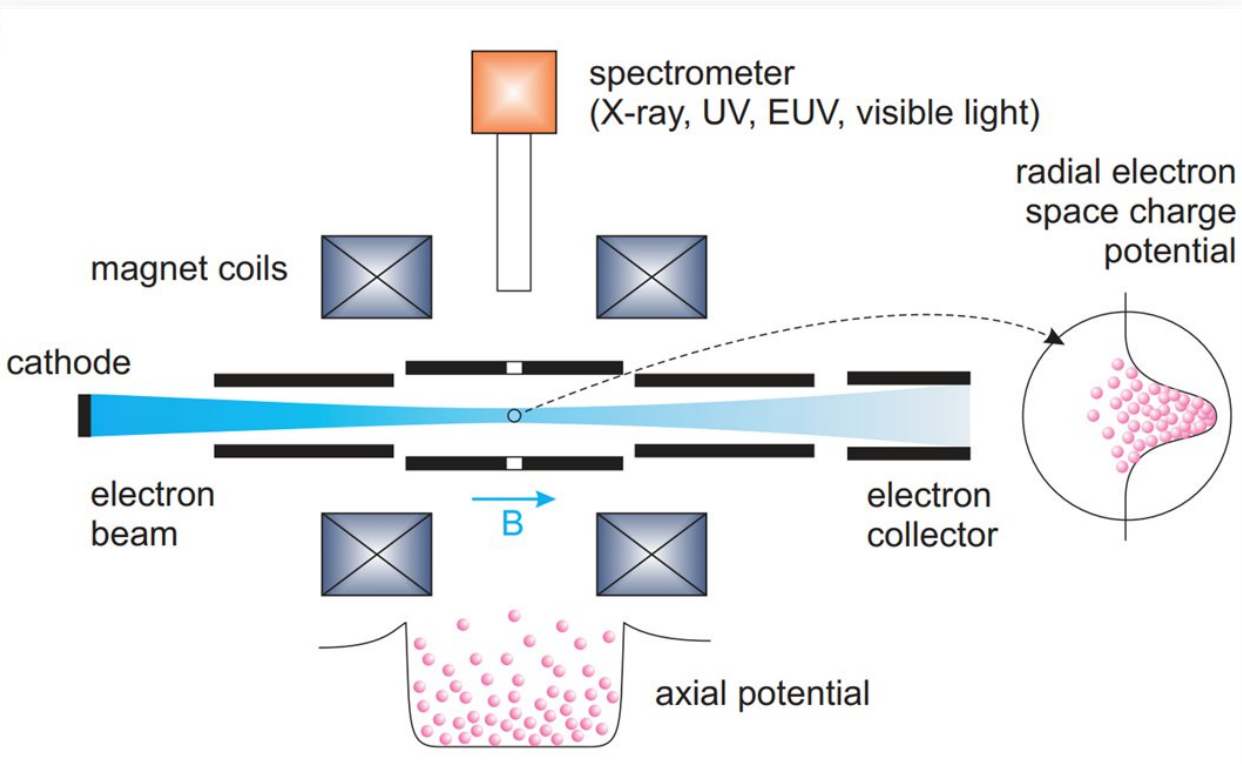

THE ASTROPHYSICAL JOURNAL SUPPLEMENT SERIES, 234:27 (25pp), 2018 February

Shah et al.

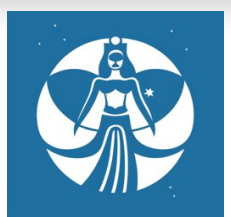
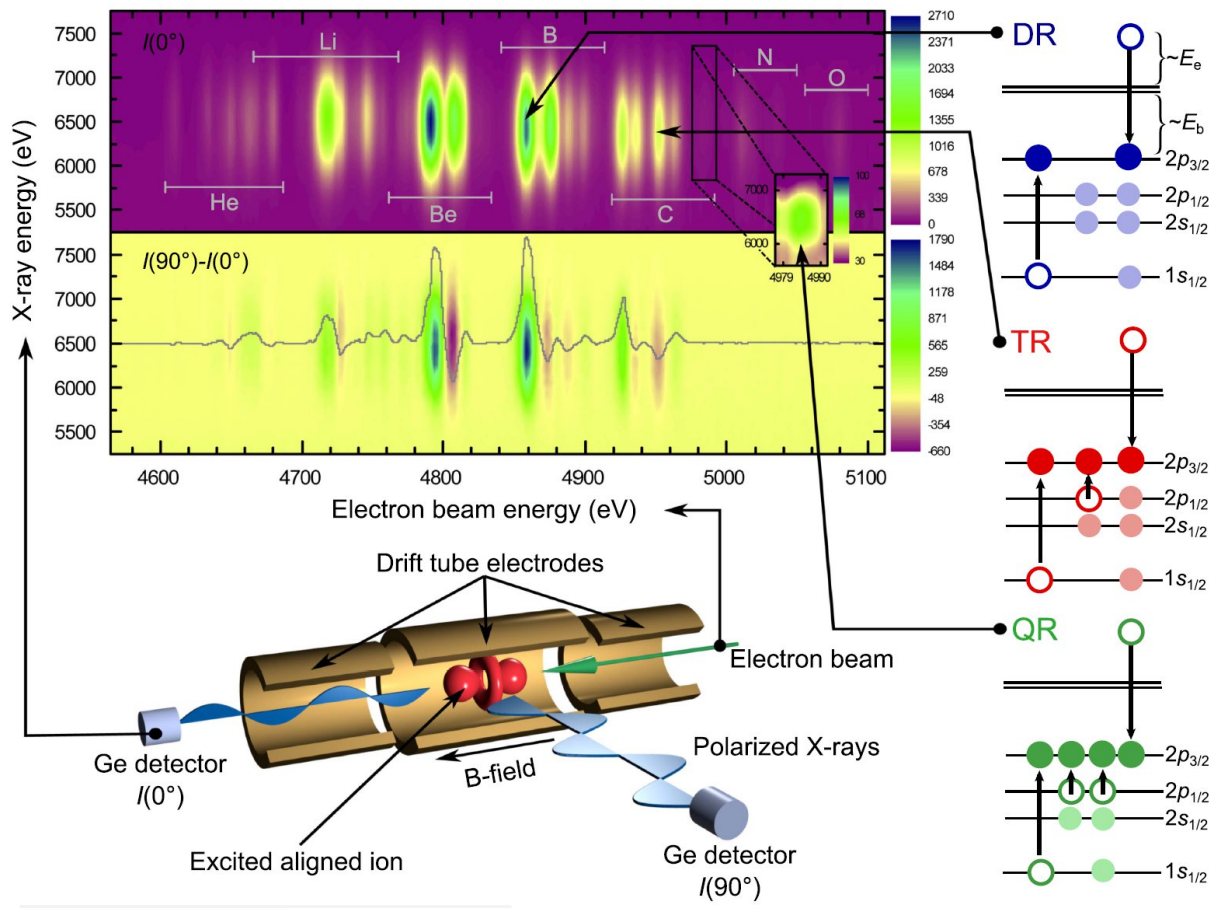

Livrable ANR-HINA



Electron Beam Ion Trap (EBIT)

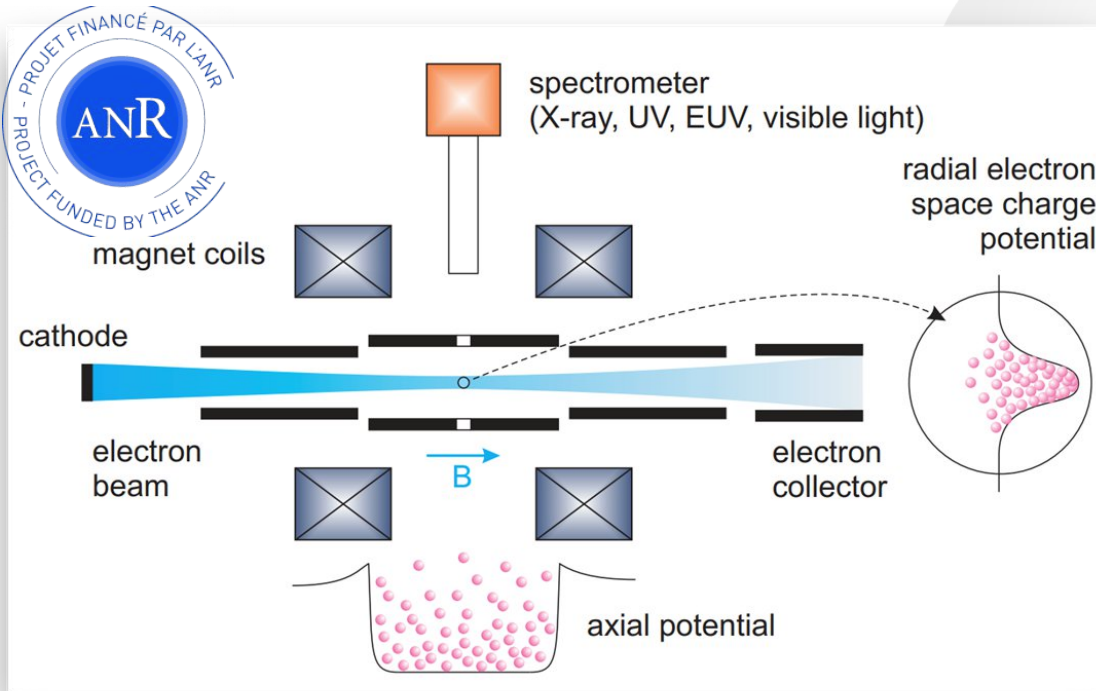

In-situ X-ray spectroscopy

Reference measurement with stable beam

Zajfman's Electrostatic Ion Beam Trap (EIBT)

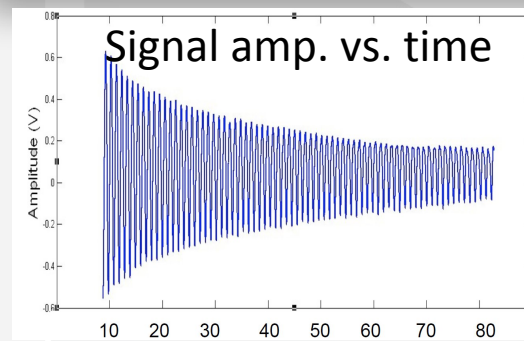
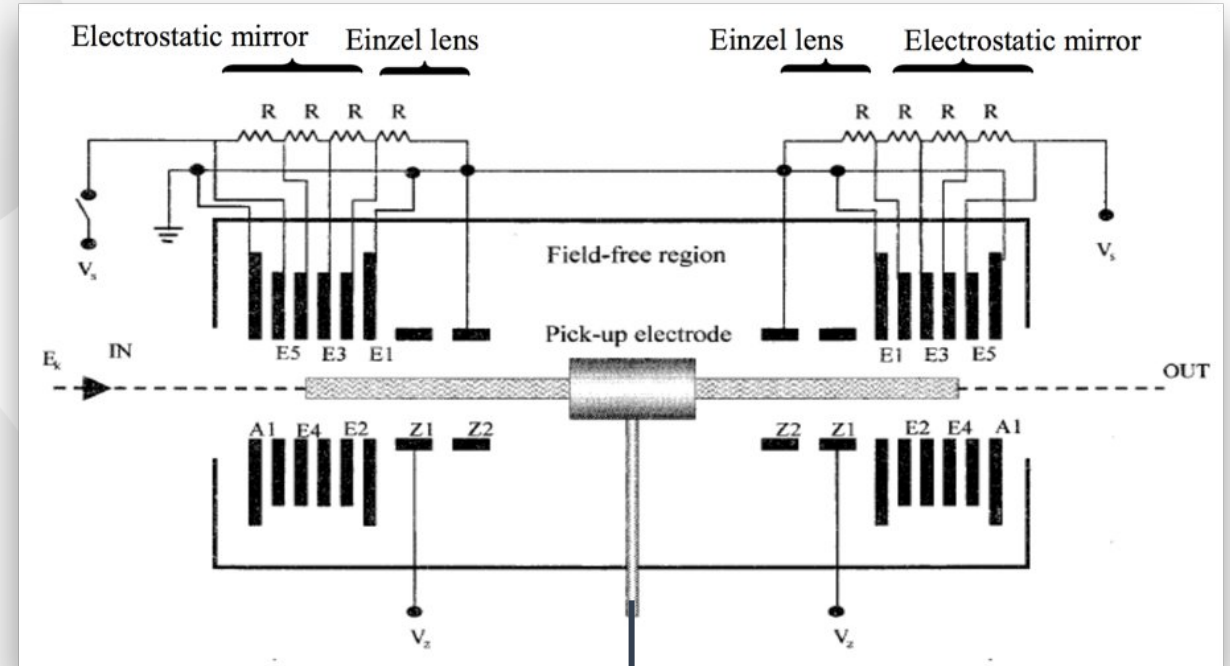

TOF mass spectrometry

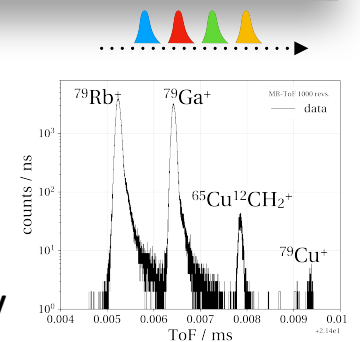



Preliminary discussion: HINA beamline @DESIR ??

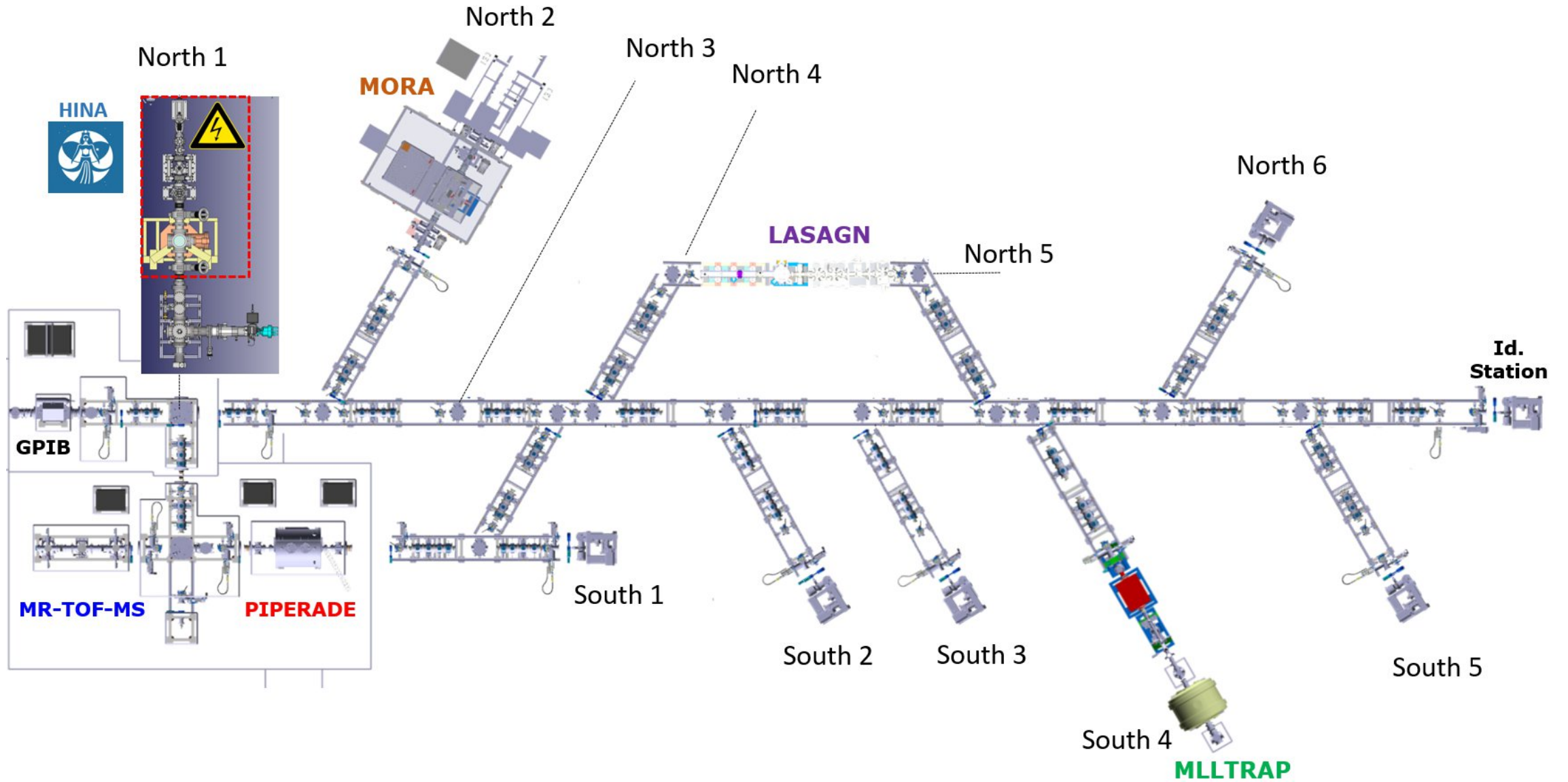

Electron Beam Ion Trap (EBIT)

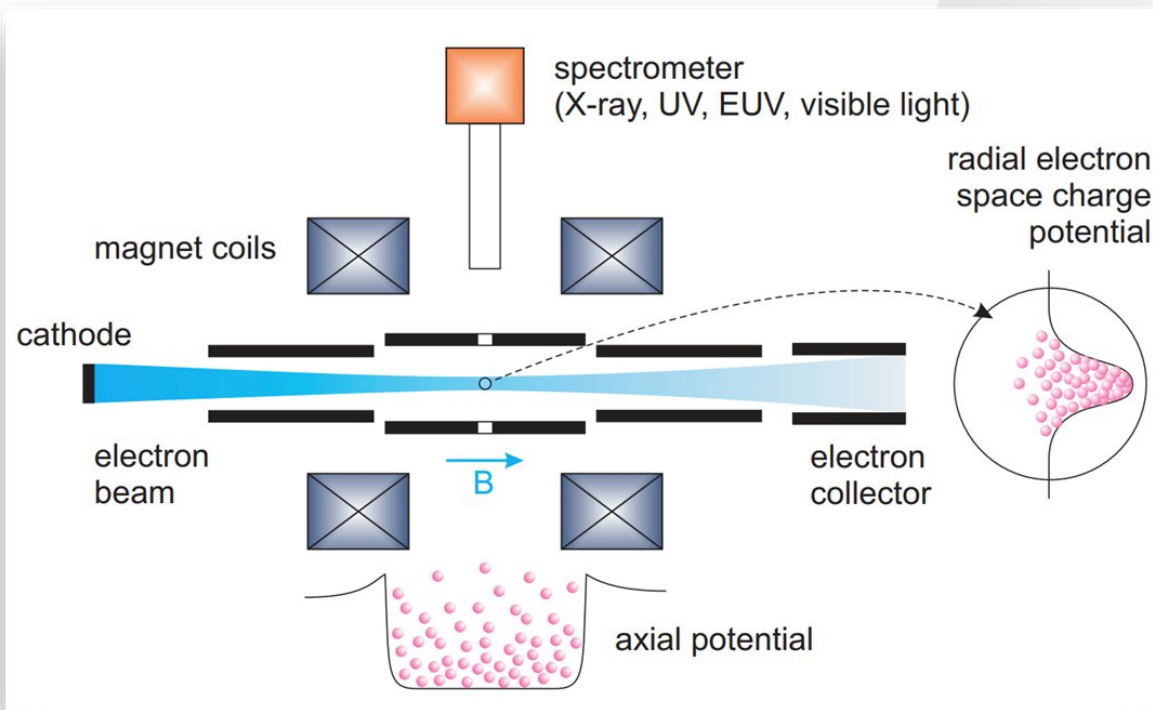

Collaboration with the Max-Planck Institut für Kernphysik (MPIK)

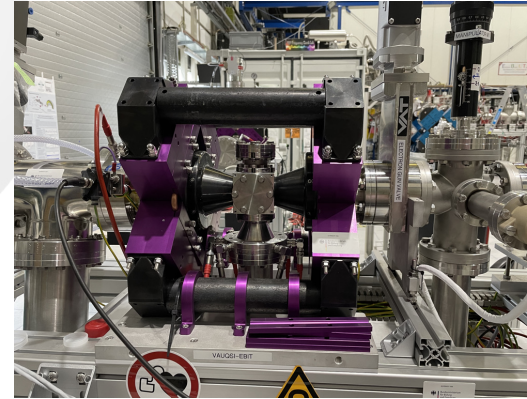

José Crespo



Klaus Blaum

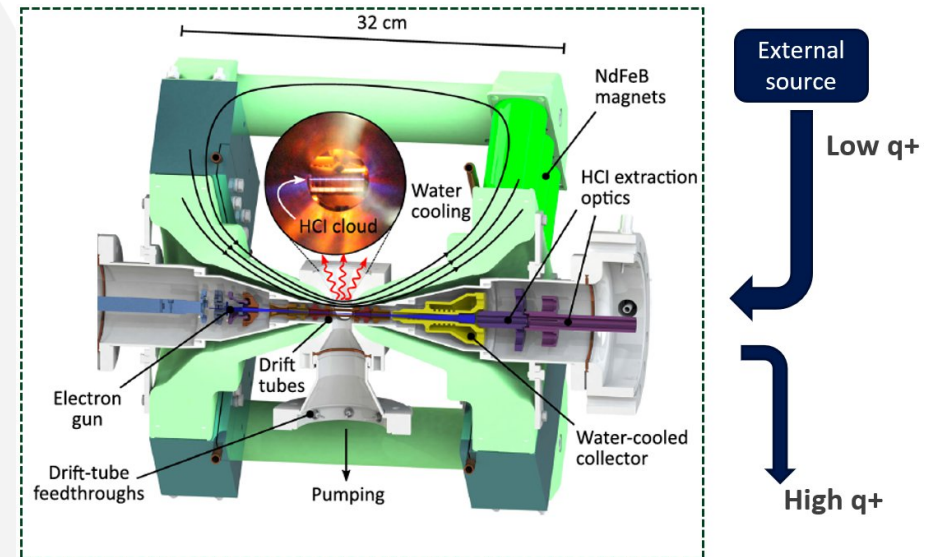



PHYSICAL REVIEW C **84**, 064309 (2011)

Nuclear electron capture in Li-like ions

Katarzyna Siegień-Iwaniuk and Zygmunt Patyk

National Centre for Nuclear Research, Hoża 69, PL-00-681 Warsaw, Poland

Decay of the 1S_0 can be very accurately calculated (QED)
 --> Suggested for Parity Non-Conservation test

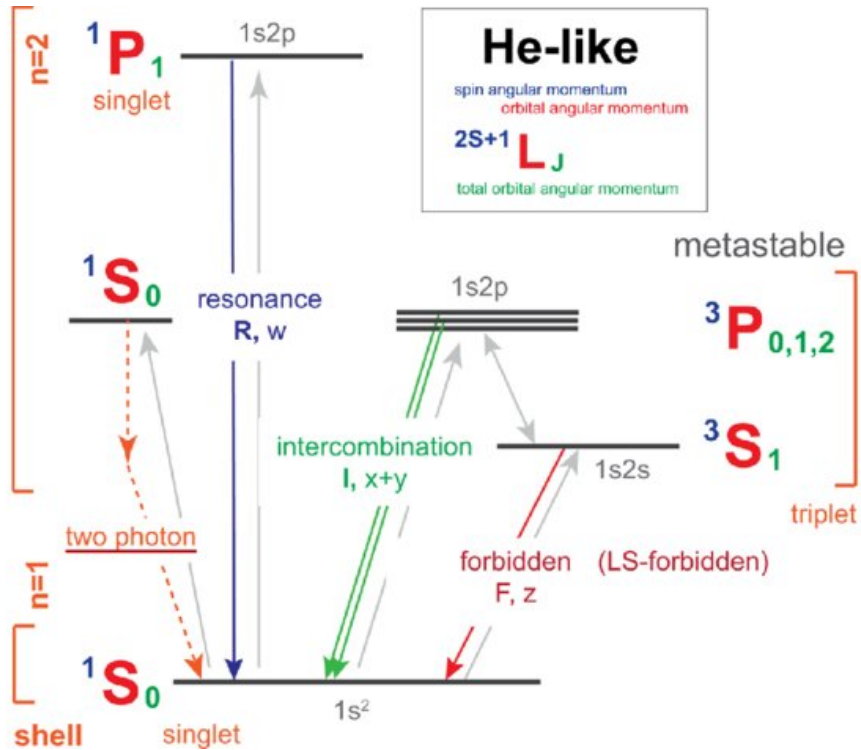

HINA



H-like ion	$I_i^{\pi_i} \rightarrow I_f^{\pi_f}$
^{19}Ne	$\frac{1}{2}^+ \rightarrow \frac{1}{2}^+$
^{37}Ar	$\frac{3}{2}^+ \rightarrow \frac{3}{2}^+$
^{64}Cu	$1^+ \rightarrow 0^+$
^{68}Ga	$1^+ \rightarrow 0^+$

For allowed EC $I \rightarrow I \pm 1$

$$\frac{P_0}{P_1} = \frac{2I + 1}{2(I \pm 1) + 1}$$

TABLE I. The ratio of probabilities P_0/P_1 that the lithium-like ion decays into the excited states 2^1S_0 and 2^3S_1 of the helium-like ion. The ratio is calculated for two types of EC decays $I \rightarrow I \pm 1$.

I_i	$\frac{P_0}{P_1}$ $I \rightarrow I - 1$	$\frac{P_0}{P_1}$ $I \rightarrow I + 1$
0		$\frac{1}{3}$
$\frac{1}{2}$		$\frac{1}{2}$
1	3	$\frac{3}{5}$
$\frac{3}{2}$	2	$\frac{2}{3}$
...
∞	1	1



Simulation studies for the EBIT acceptance



Michele Sguazzin
Postdoc CNRS-in2p3
Oct.2023-present

Mission : Development of highly charged ions physics at DESIR/GANIL

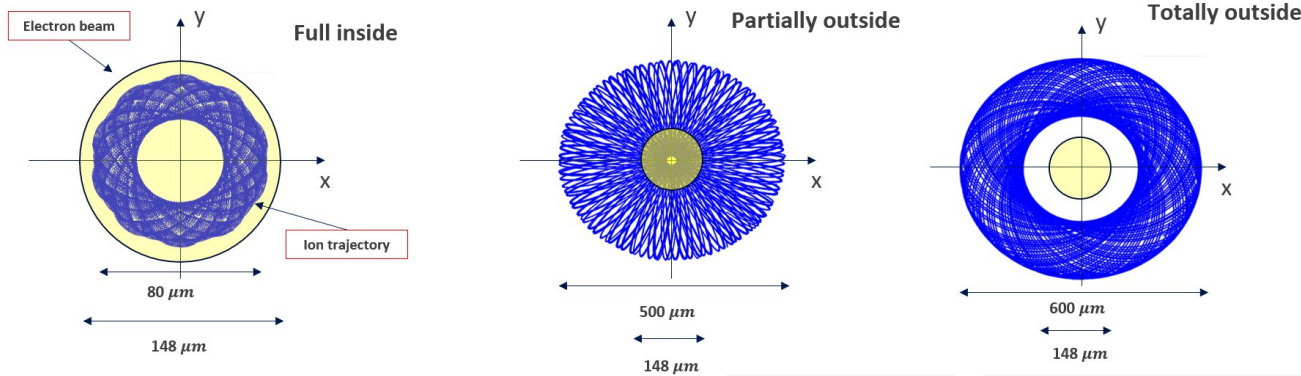
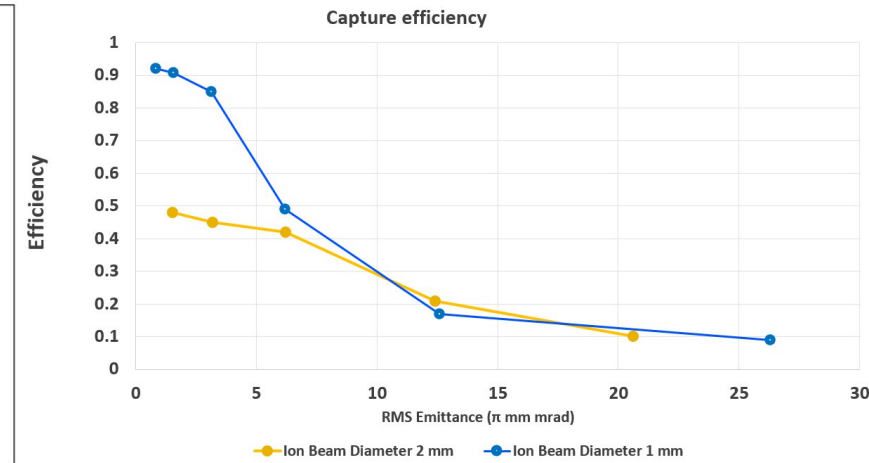
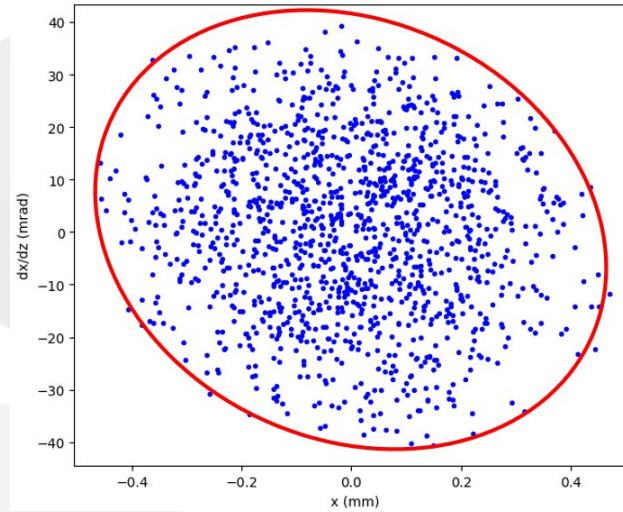
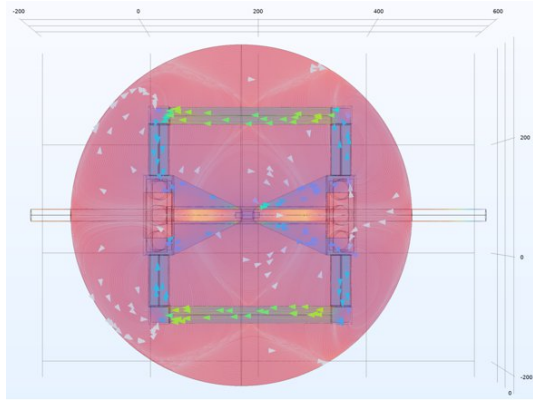

The EBIT acceptance depends on several variables:

- electron beam and the magnetic field
- Energy of the ion beam before injection **20 keV**

Electron beam: $I_e = 0.08 A$, $E_e = 10 keV$

Magnetic field: $B = 0.86 T$

RMS Emittance (ϵ_{RMS}) in x & y about $3.7 \pi mm \cdot mrad$
Effective emittance ϵ_{eff} : $\epsilon_{eff} = 4 \cdot \epsilon_{RMS} = 14.8 \pi mm \cdot mrad$



Towards in-situ X-ray spectroscopy (preliminary!)



NEW!!
To be tested @MPIK

Michele Sguazzin

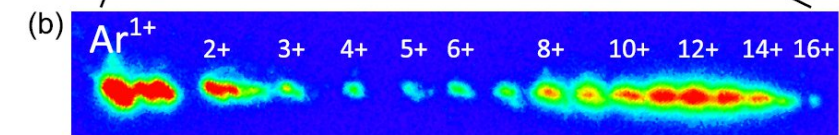
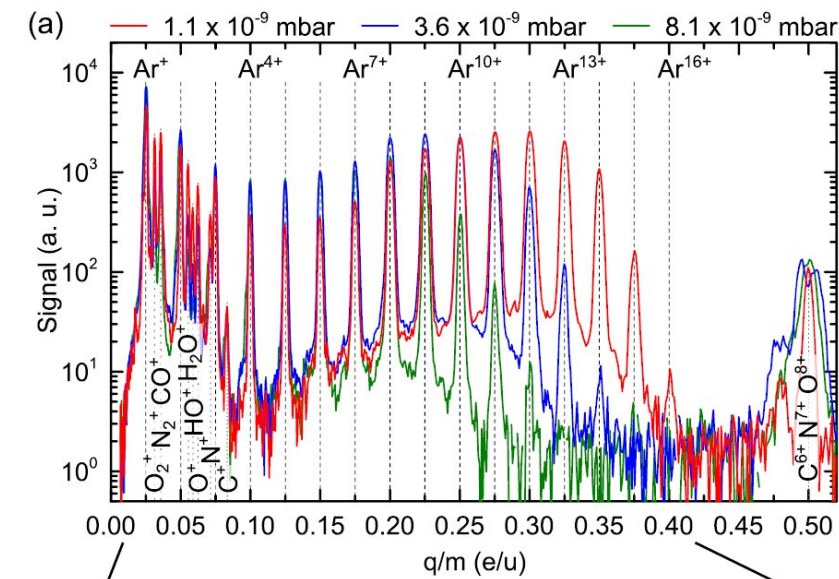

Micke et al, Rev. Sci. Instrum. 89, 063109 (2018):
Electron gun operation: 4mA, 2.8keV

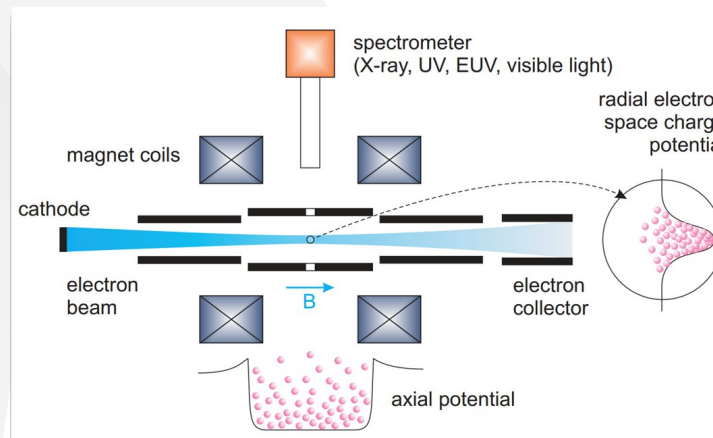
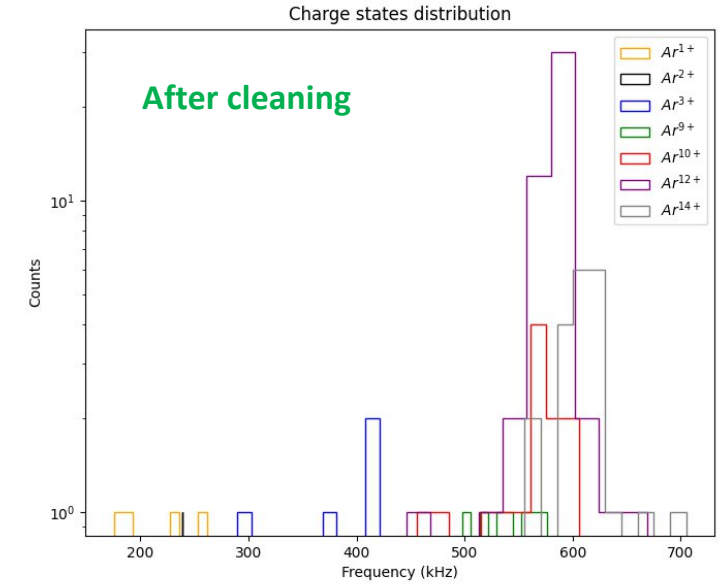
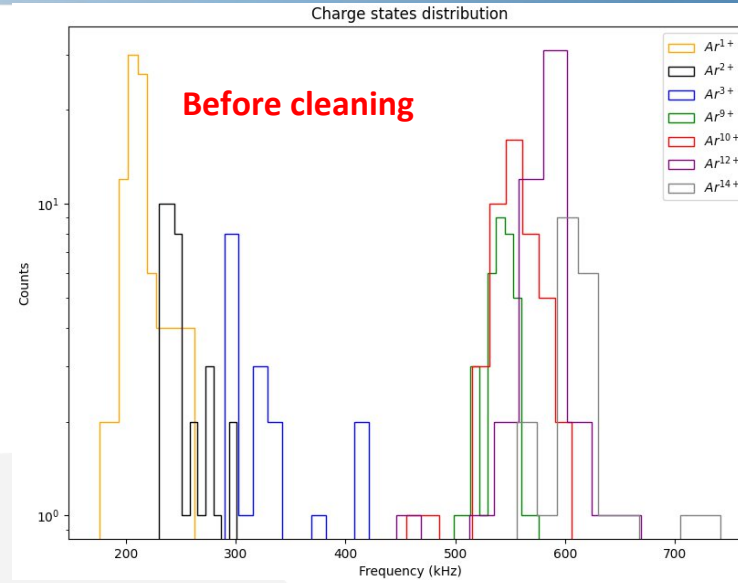

Cleaning: SWIFT method
(Stored Waveform Inverse Fourier Transform)
M. Wiesel, PhD thesis (TUD) 2017

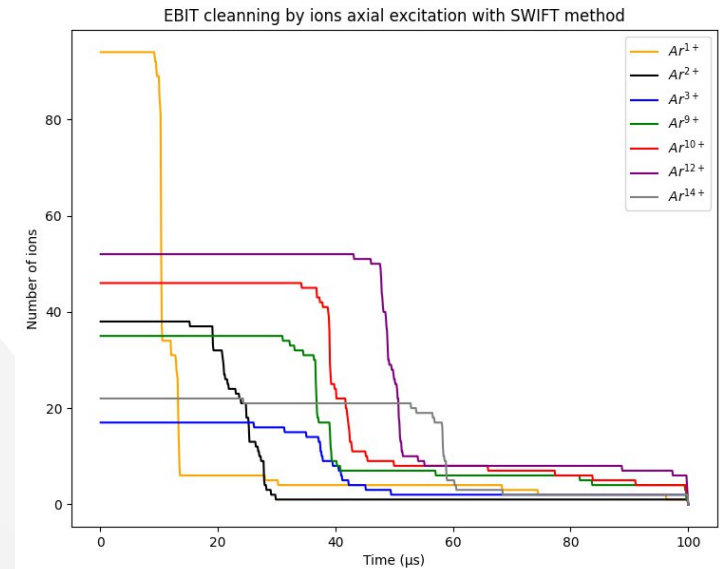



Tools under development for DESIR



Serge Della Negra

Liquid metal ion source
Cu, Ga



Offline IS
(LMIS)



Charge
Breeding



Trapping
observation



Maroua Benhatchi

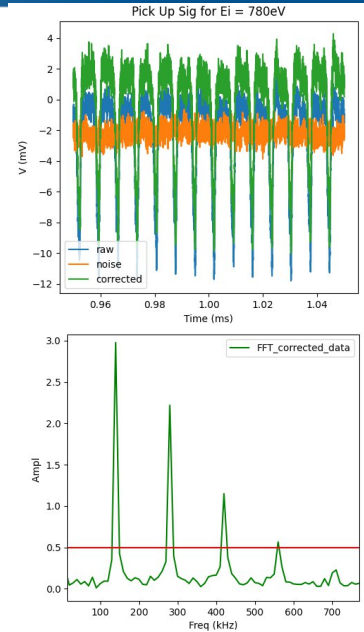
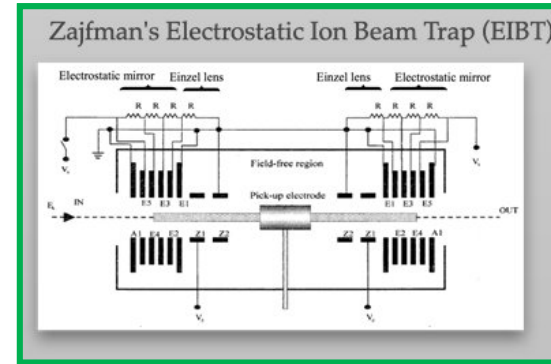
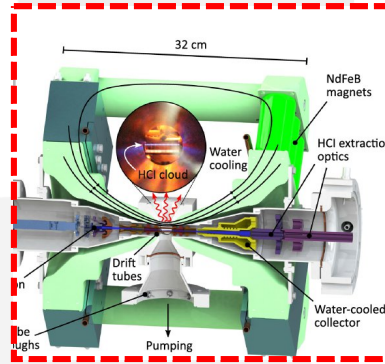

Simulations:

- Injection optics
- Emittance acceptance
- In-trap spectroscopy

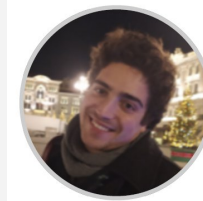

Michele Sguazzin

H-like ion	$I_i^{\pi_i} \rightarrow I_f^{\pi_f}$
ECR	$^{19}\text{Ne} \quad \frac{1^+}{2} \rightarrow \frac{1^+}{2}$
	$^{37}\text{Ar} \quad \frac{3^+}{2} \rightarrow \frac{3^+}{2}$
LMIS	$^{64}\text{Cu} \quad 1^+ \rightarrow 0^+$
	$^{68}\text{Ga} \quad 1^+ \rightarrow 0^+$

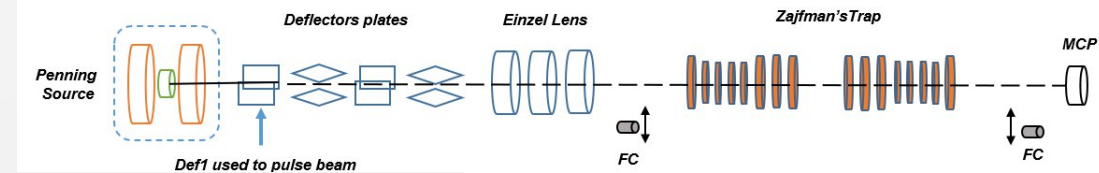
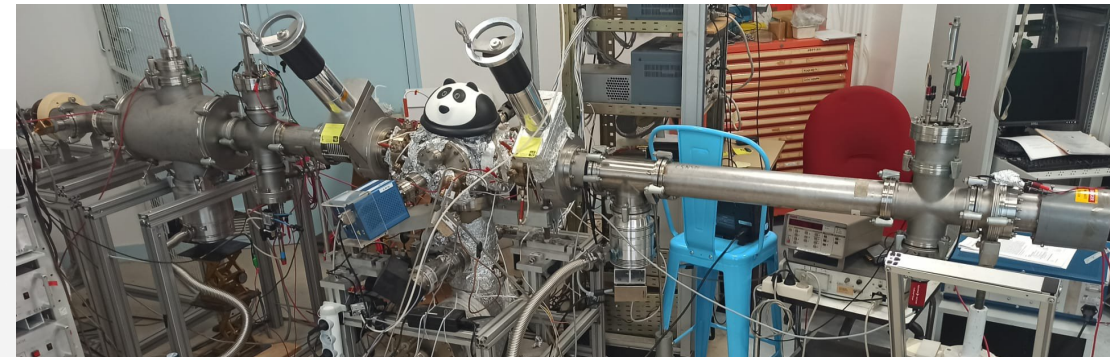

Cu beam is under development



Trapping HCl: UHV issue

Trapping of A_r^{11+} ions @LKB

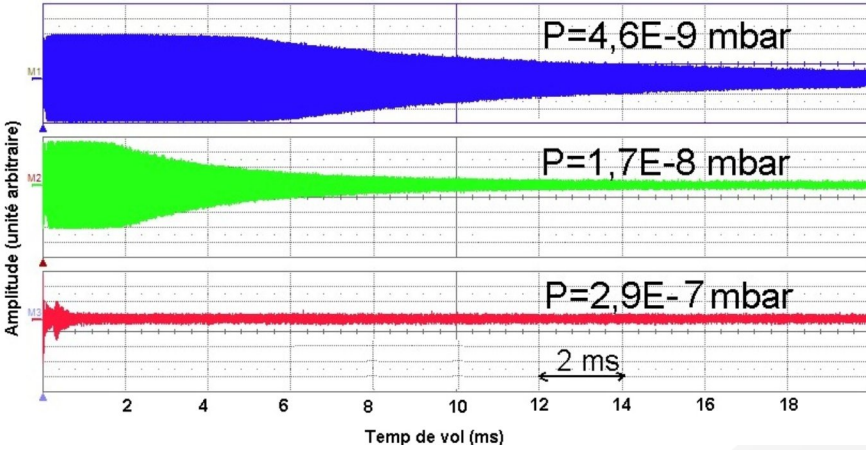

Michele Sguazzin

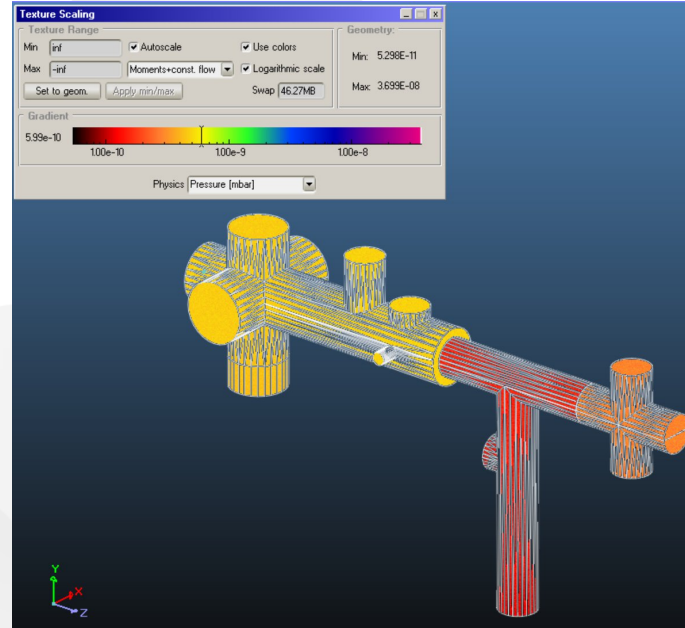

Partial pressure of H_2

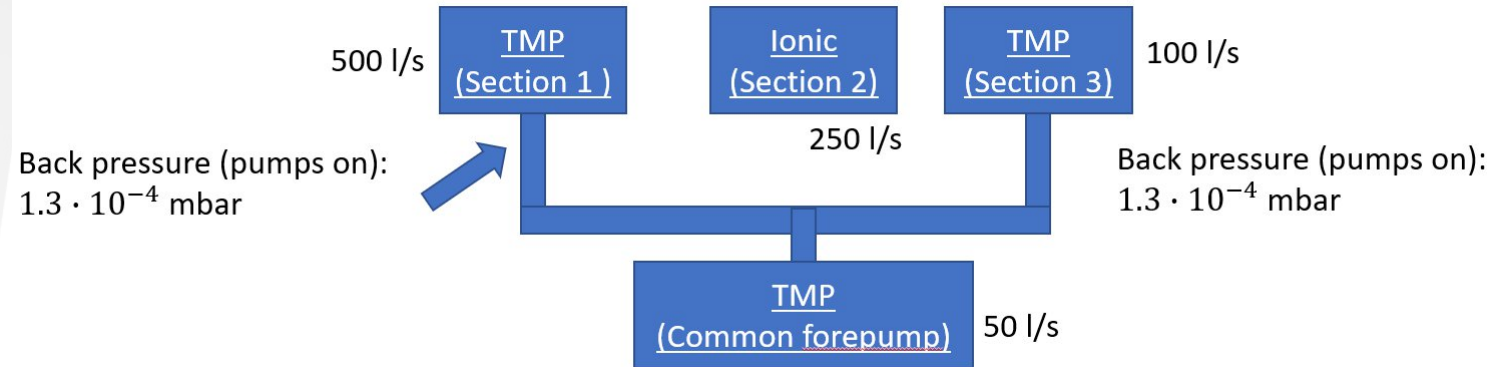
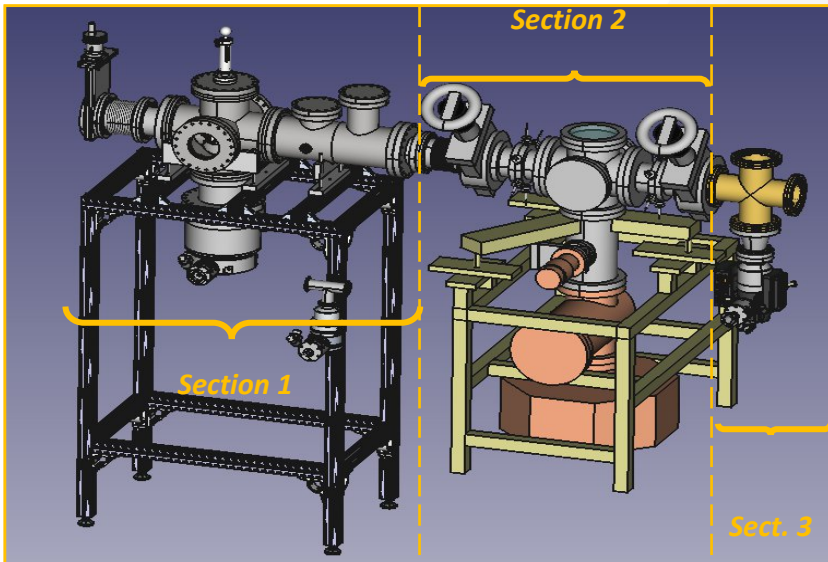
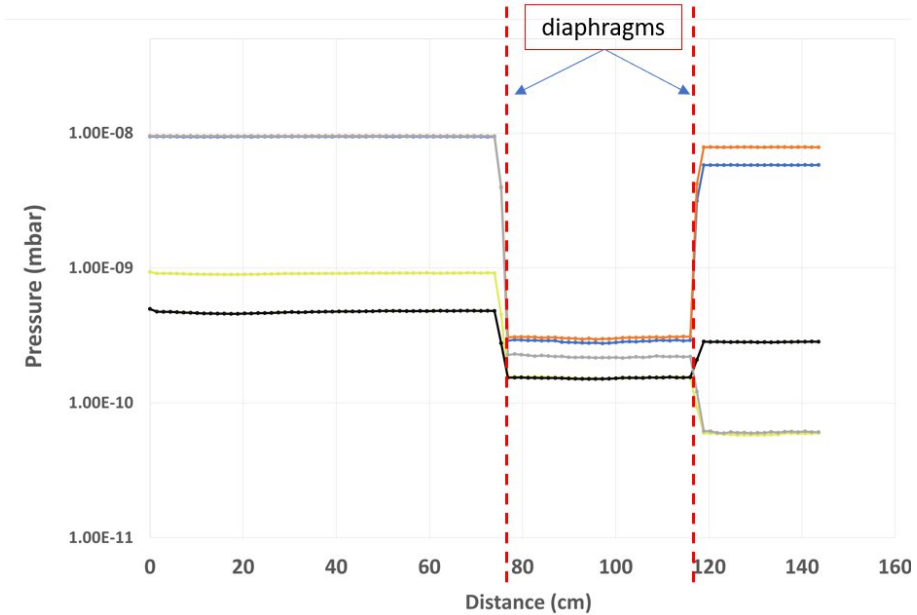



Some key numbers

Isobaric purification:

$$^{19}\text{F} / ^{19}\text{Ne} \delta m/m \approx 5,000 \quad \text{HRS}$$

$$^{37}\text{Ar} / ^{37}\text{Cl} \delta m/m \approx 42,000 \quad \text{HRS} \quad \text{MRTOF}$$

$$^{64}\text{Cu} / ^{64}\text{Ni} \delta m/m \approx 35,000 \quad \text{HRS} \quad \text{MRTOF}$$

$$^{68}\text{Ga} / ^{68}\text{Zn} \delta m/m \approx 22,000 \quad \text{HRS}$$

Yields:

^{19}Ne production @SPIRAL1 LEB: $1.8 \cdot 10^8$ pps ^{37}Ar
estimate @SPIRAL1 LEB: $9.1 \cdot 10^7$ pps

^{64}Cu estimate @SPIRAL1 LEB: $4 \cdot 10^6$ pps

^{68}Ga production @SPIRAL1 LEB: $9.4 \cdot 10^5$ pps

Emittance acceptance HINA @30keV:

HINA exp. $\epsilon_{\text{RMS}} \approx 3 \pi \text{ mm} \cdot \text{mrad}$

DESIR-GPIB $\epsilon_{\text{RMS}} \approx 1.2 \pi \text{ mm} \cdot \text{mrad}$

Bunched mode:

DESIR-GPIB: 10^5 ions/bunch

Efficiency 0.1% for ^{19}Ne ($T_{1/2} = 17\text{s}$)

--> 10 events in 25ms

--> 100 events in 250ms

Continuous mode to be tested

Others:

HV platform

Cooling water



Soon we will have one too...

HINA



HINA team @MPIK (Apr. 2025)



Serge Della Negra



Isabelle Ribaud



Enrique Minaya Ramirez



Maroua Benhatchi



David Lunney



Vladimir Manea



Fran ois Daubisse



Alexandre Migayron



Denis DOUILLET



Bruno MERCIER



Jihan Maalmi



Denis Reynet



EC on He-like and Li-like ^{19}Ne

Beam resolution
FWHM = 10V

X-ray detection resolution
FWHM = 150eV

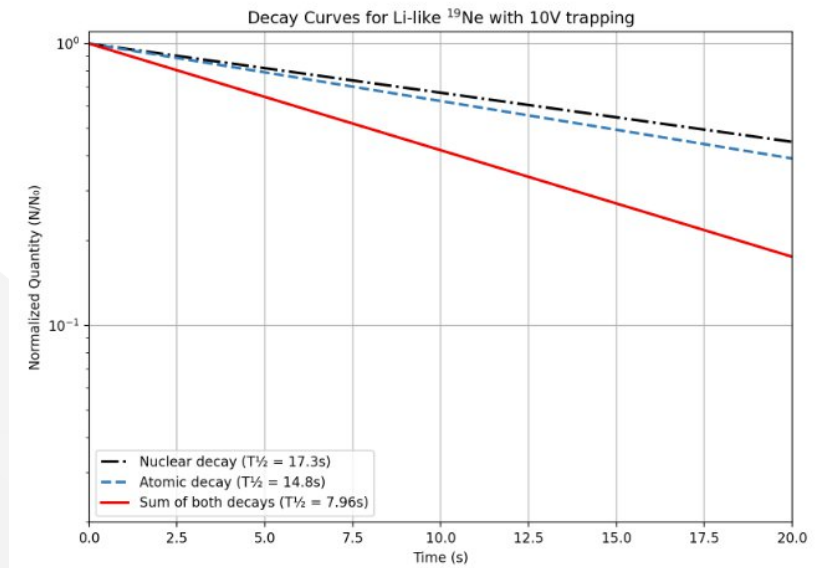
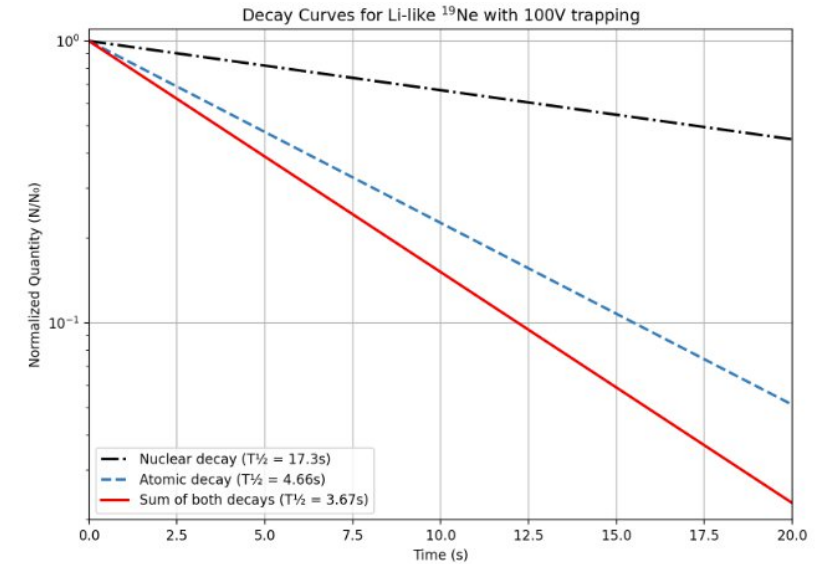
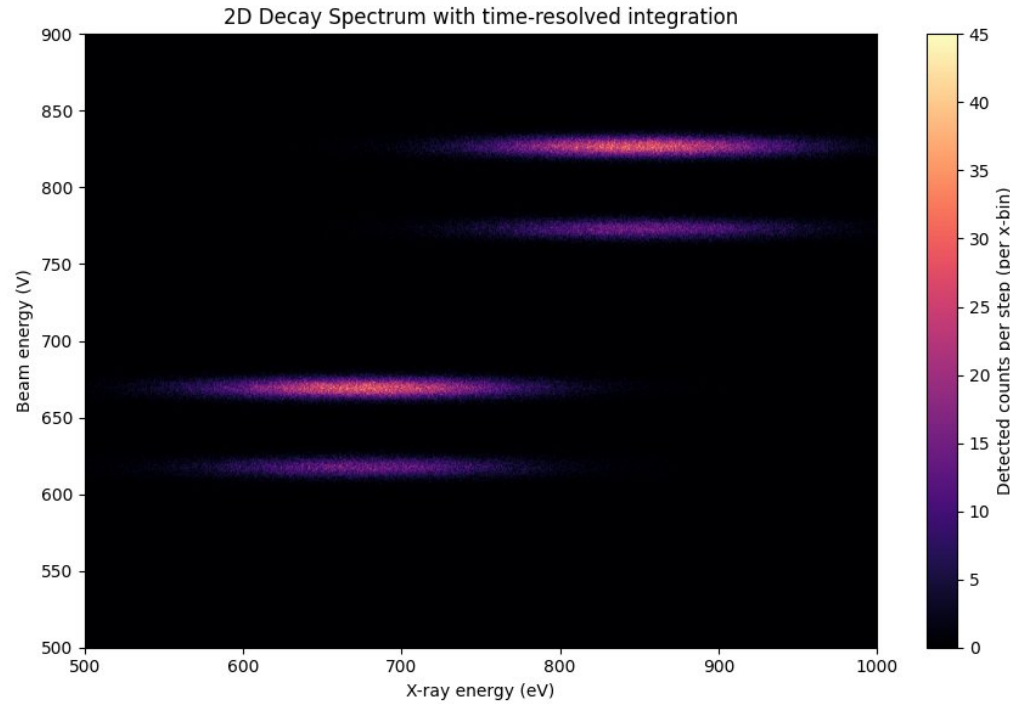



HINA



Decay highly charged light ions

Trap-based setup

Nuclear physics
Astrophysics

High precision
New applications

Adding a new dimension @DESIR for exploring the nuclear chart and increasing scientific impact

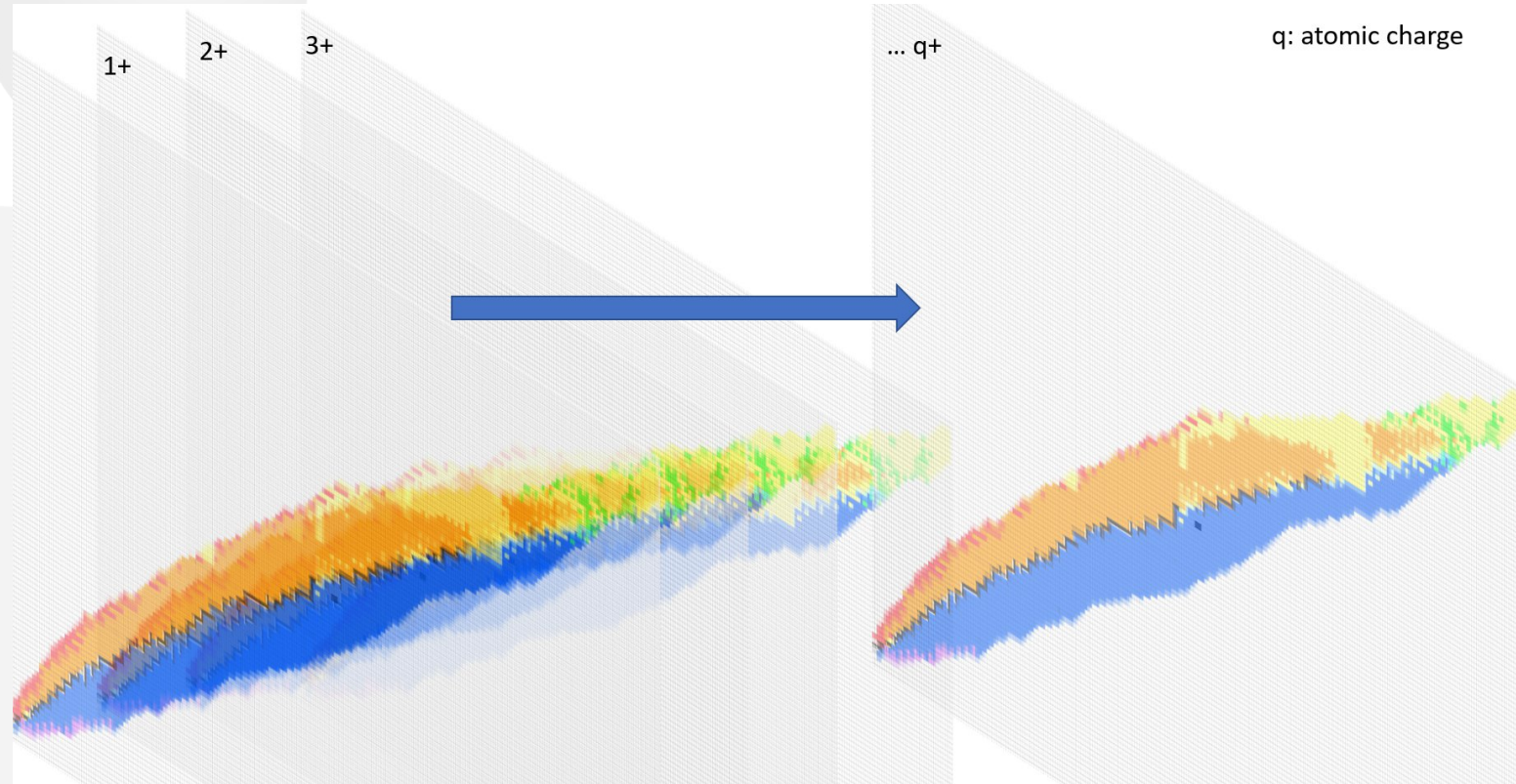



Where do we find them?

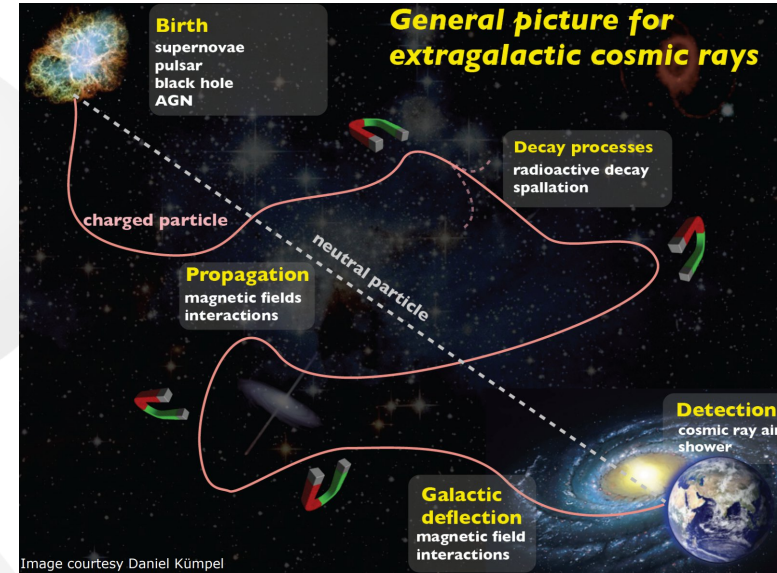
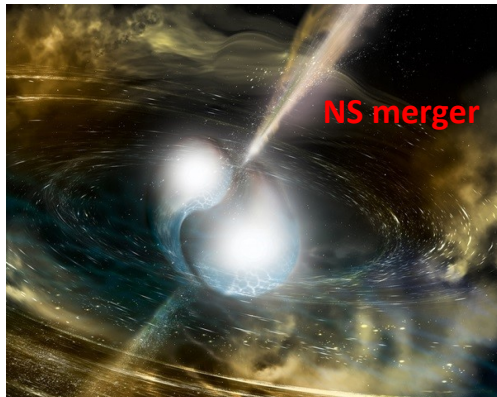
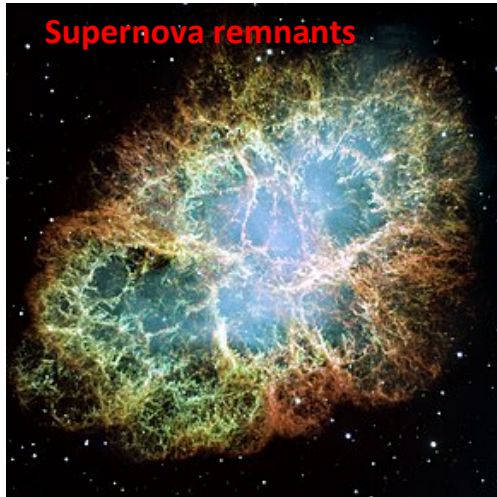

Measured H-,He- ¹⁴⁰Pr at GSI

Litvinov+, PRL, 2007

Orbital EC in H-like ions

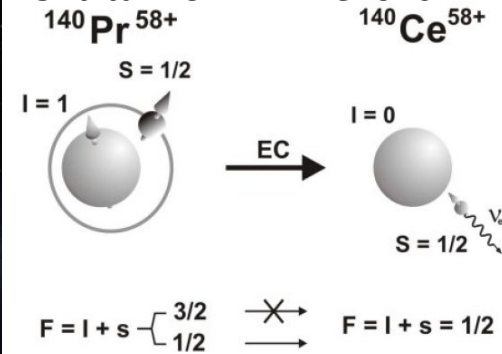

Secondary Li, Be, B, and F nuclei in cosmic rays are produced by the collision of primary cosmic rays, C, O, Ne, Mg, Si, ..., Fe, with the interstellar medium.

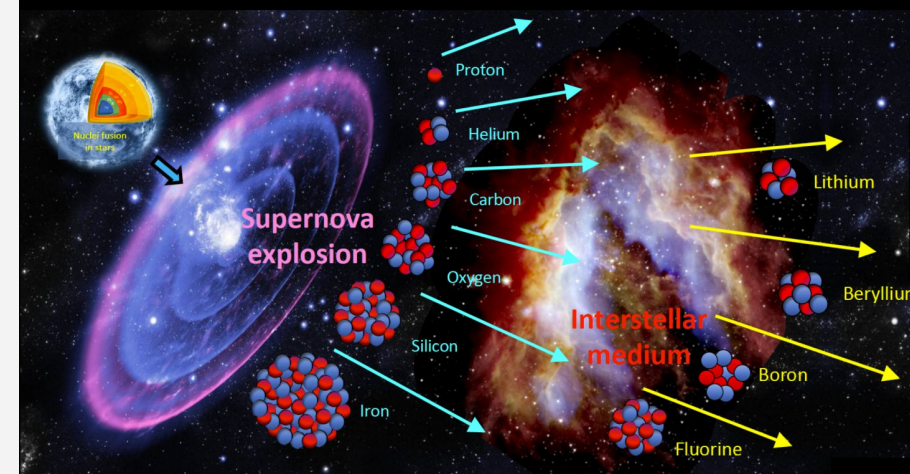

Measurements of the secondary cosmic ray nuclei fluxes and the secondary to primary flux ratios are important in understanding the propagation of cosmic rays in the Galaxy.

HINA: Nuclear decay of unstable HICs



PHYSICAL REVIEW C 77, 014306 (2008)

Orbital electron capture decay of hydrogen- and helium-like ions

Zygmunt Patyk,¹ Jan Kurcewicz,² Fritz Bosch,³ Hans Geissel,³ Yuri A. Litvinov,³ and Marek Pfützner²

¹Soltan Institute for Nuclear Studies, Hoża 69, PL-00-681 Warsaw, Poland

²Institute of Experimental Physics, Warsaw University, Hoża 69, PL-00-681 Warsaw, Poland

³Gesellschaft für Schwerionenforschung (GSI), Planckstrasse 1, D-64291 Darmstadt, Germany

(Received 3 August 2007; published 10 January 2008)

Measured H-,He- ¹⁴⁰Pr at GSI

Litvinov+, PRL, 2007

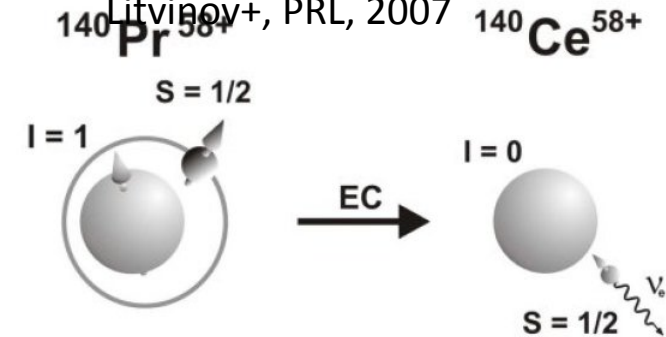

$$F = I + s \begin{cases} 3/2 \\ 1/2 \end{cases} \begin{matrix} \xrightarrow{\times} \\ \xrightarrow{\quad} \end{matrix} F = I + s = 1/2$$

Ion	λ_{β^+} (sec ⁻¹)	λ_{EC} (sec ⁻¹)
¹⁴⁰ Pr ⁵⁹⁺	0.001 58(8)	...
¹⁴⁰ Pr ⁵⁸⁺	0.001 61(10)	0.002 19(6)
¹⁴⁰ Pr ⁵⁷⁺	0.001 54(11)	0.001 47(7)

Factor 2/3

ANNUAL REVIEW OF NUCLEAR AND PARTICLE SCIENCE Volume 57, 2007

Review Article

Cosmic-Ray Propagation and Interactions in the Galaxy

Andrew W. Strong¹, Igor V. Moskalenko², and Vladimir S. Ptuskin³

Hide Affiliations

Affiliations:

¹Max-Planck-Institut für extraterrestrische Physik, 85741 Garching, Germany; email: aws@mpe.mpg.de

²Hansen Experimental Physics Laboratory and Kavli Institute for Particle Astrophysics and Cosmology, Stanford University, Stanford, California 94305; email: imos@stanford.edu

³Institute for Terrestrial Magnetism, Ionosphere and Radiowave Propagation of the Russian Academy of Sciences (IZMIRAN), Troitsk, Moscow region 142190, Russia; email: vptuskin@izmiran.ru

Starting with the heaviest primary nucleus considered (e.g. ⁶⁴Ni) the propagation solution is used to compute the source term for its spallation products, which are then propagated in turn, and so on down to protons, secondary electrons and positrons, and antiprotons. In this way secondaries, tertiaries etc. are included. (Production of ¹⁰B via the ¹⁰Be-decay channel is important and requires a second iteration of this procedure.) GALPROP includes K-capture and electron stripping processes, where a nucleus with an electron (H-like) is considered a separate species because of the difference in the lifetime. Since H-like atoms have only one K-shell electron, the K-capture decay half-life has to be increased by a factor of 2 compared to the measured half-life value. Primary electrons are treated



PHYSICAL REVIEW LETTERS 133, 232701 (2024)

Editors' Suggestion

Bound-State Beta Decay of $^{205}\text{Tl}^{81+}$ Ions and the LOREX Project

nature > articles > article

Article | [Open access](#) | Published: 13 November 2024

High-temperature ^{205}Tl decay clarifies ^{205}Pb dating in early Solar System



Romain Bellet (CIFRE)
Co-encadrement IJCLab

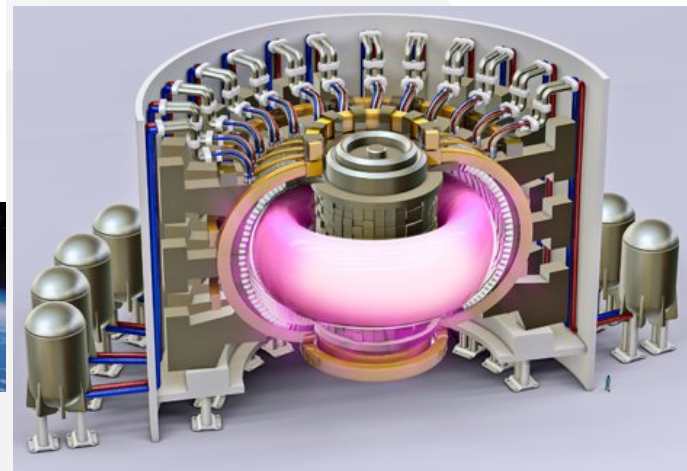

nature > letters > article

Letter | Published: 08 February 2018

Isomer depletion as experimental evidence of nuclear excitation by electron capture

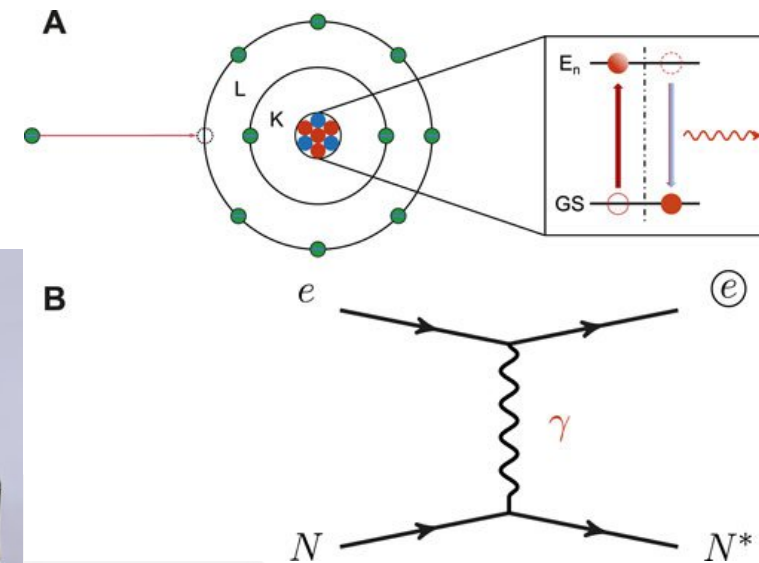

Energy storage:
nuclear battery?





NEEC search at TITAN-EBIT

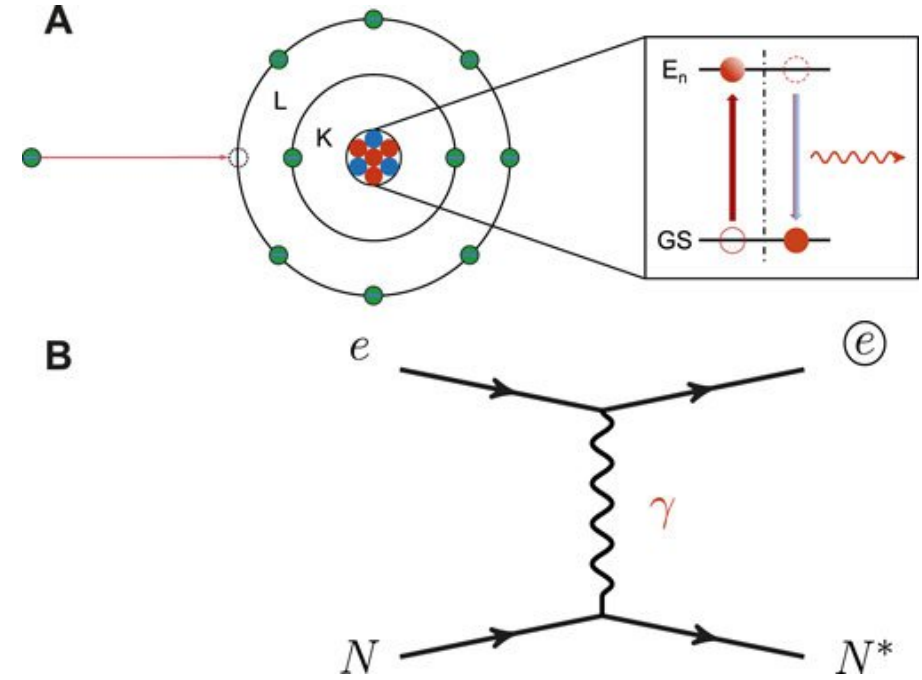
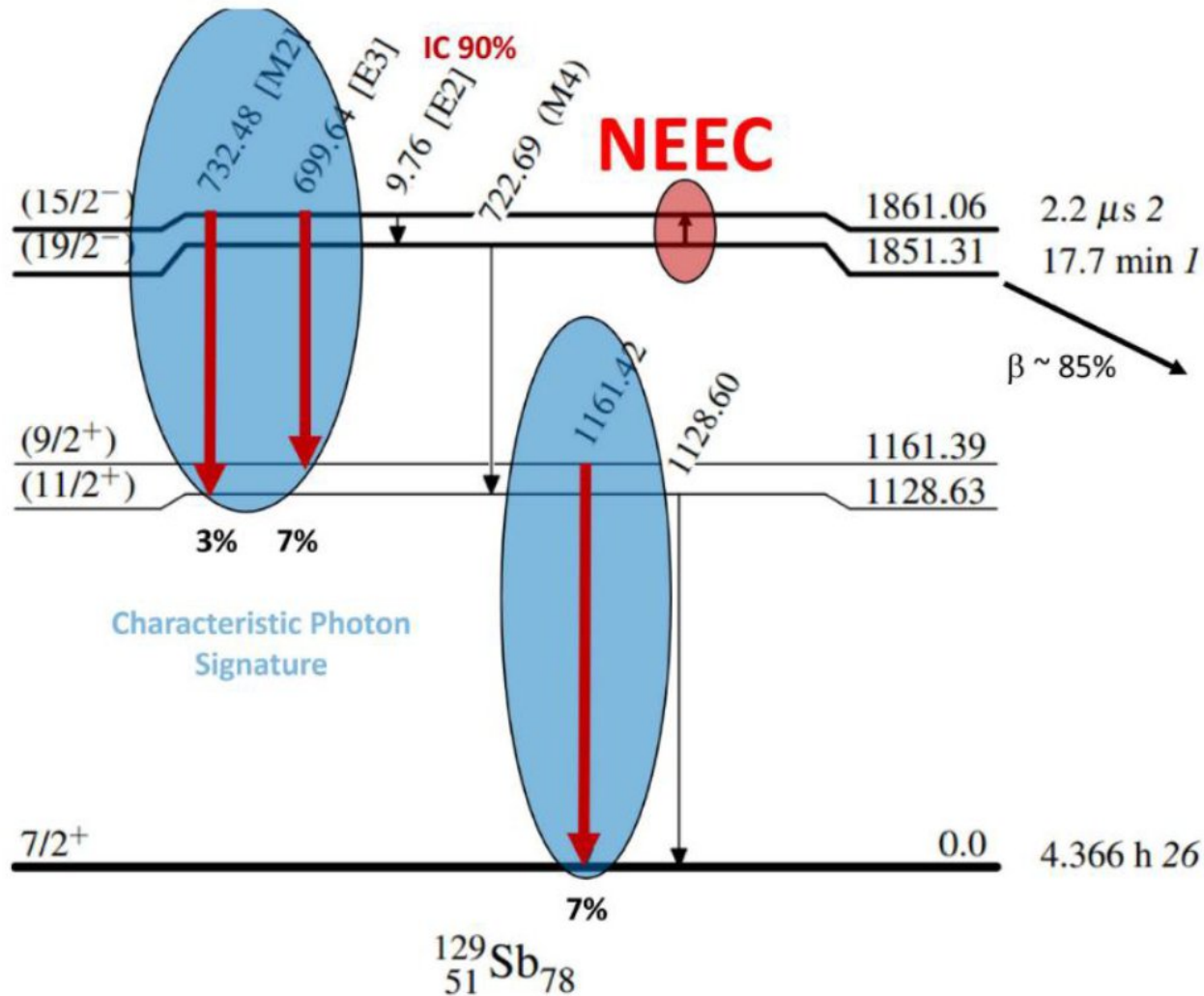

nuclear battery?

