

# Towards a microscopic water-based fiber-optic detector for real-time, *in-vivo*, tissue-equivalent radiation dosimetry

**Kate Szabo**

Fernanda C. Rodrigues Machado, Jingyi Bian,  
Shirin Enger, Lilian Childress, Jack Sankey  
**IC3DDose 2026**



**McGill**

Department of  
Physics

Département de  
Physique

Quantum Optics and Sensing Lab

Apply quantum optics + precision sensing techniques to address dosimetry limitations

- ▶ Measure radiation-induced absorption by **hydrated electrons** in water
- ▶ Detection enhanced by **optical cavities**
- ▶ Microscopic detector sizes using optical **fiber mirrors**

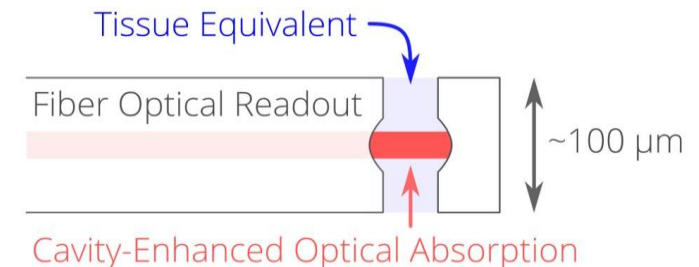

# Our goal: address current challenges in dosimetry

1. **Tissue-equivalent** detection
2. Universal **compatibility** (photon, electron, *and* proton radiation)
3. High **sensitivity**
4. ***In-vivo*** operation with **real-time** readout

# Our goal: address current challenges in dosimetry

1. **Tissue-equivalent** detection
2. Universal **compatibility** (photon, electron, *and* proton radiation)
3. High **sensitivity**
4. ***In-vivo*** operation with **real-time** readout

Apply precision optical sensing techniques to simultaneously address these challenges

- ▷ Develop a **water-based** radiation dosimeter with **fiber-optical readout**

# Our goal: address current challenges in dosimetry

1. **Tissue-equivalent** detection
2. Universal **compatibility** (photon, electron, *and* proton radiation)
3. High **sensitivity**
4. **In-vivo** operation with **real-time** readout

Apply precision optical sensing techniques to simultaneously address these challenges

- ▷ Develop a **water-based** radiation dosimeter with **fiber-optical readout**

# Our goal: address current challenges in dosimetry

1. **Tissue-equivalent** detection
2. Universal **compatibility** (photon, electron, *and* proton radiation)
3. High **sensitivity**
4. **In-vivo** operation with **real-time** readout

Apply precision optical sensing techniques to simultaneously address these challenges

- ▷ Develop a **water-based** radiation dosimeter with **fiber-optical readout**

# Our goal: address current challenges in dosimetry

1. **Tissue-equivalent** detection
2. Universal **compatibility** (photon, electron, *and* proton radiation)
3. High **sensitivity**
4. **In-vivo** operation with **real-time** readout

Apply precision optical sensing techniques to simultaneously address these challenges

- ▷ Develop a **water-based** radiation dosimeter with **fiber-optical readout**

# Fiber Fabry-Perot cavities (FFPCs)

- ▷ **Atomically smooth micro-mirrors** on the ends of optical fibers
- ▷  $\mu\text{m}$ -scale optical cavities the width of a human hair

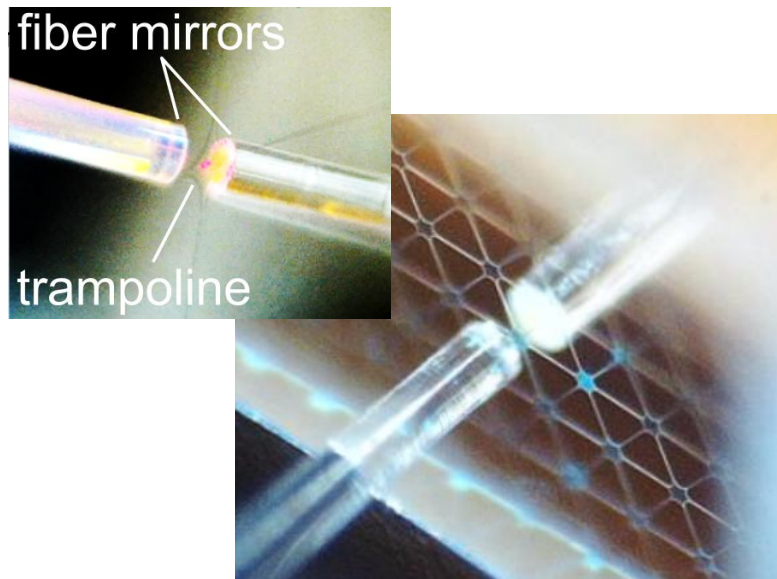
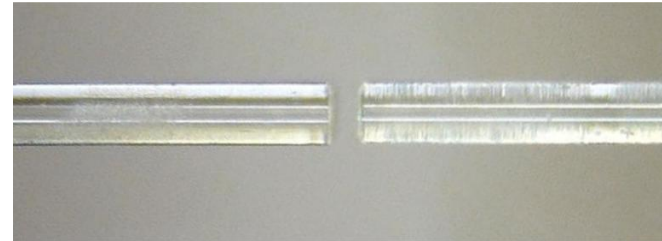

Quantum optomechanics

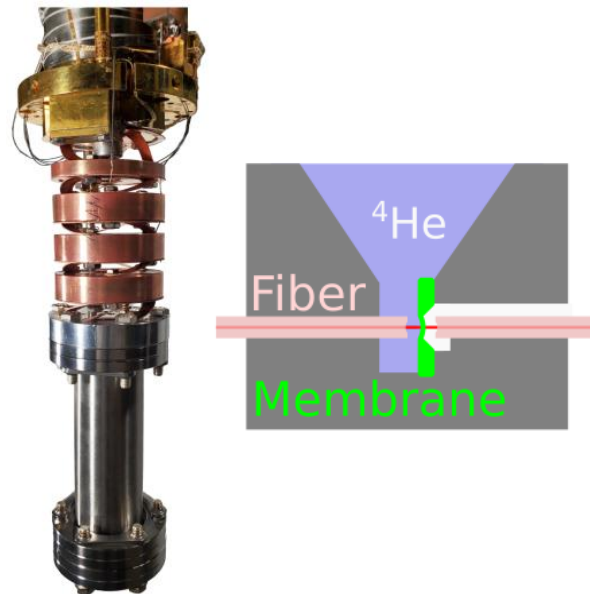

Dark matter detection

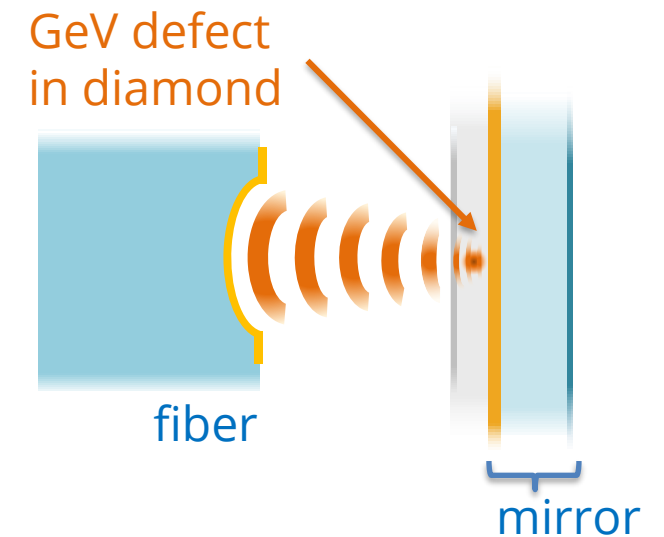

Diamond quantum optics

# Fiber Fabry-Perot cavities (FFPCs)

- ▷ **Atomically smooth micro-mirrors** on the ends of optical fibers
- ▷  $\mu\text{m}$ -scale optical cavities the width of a human hair

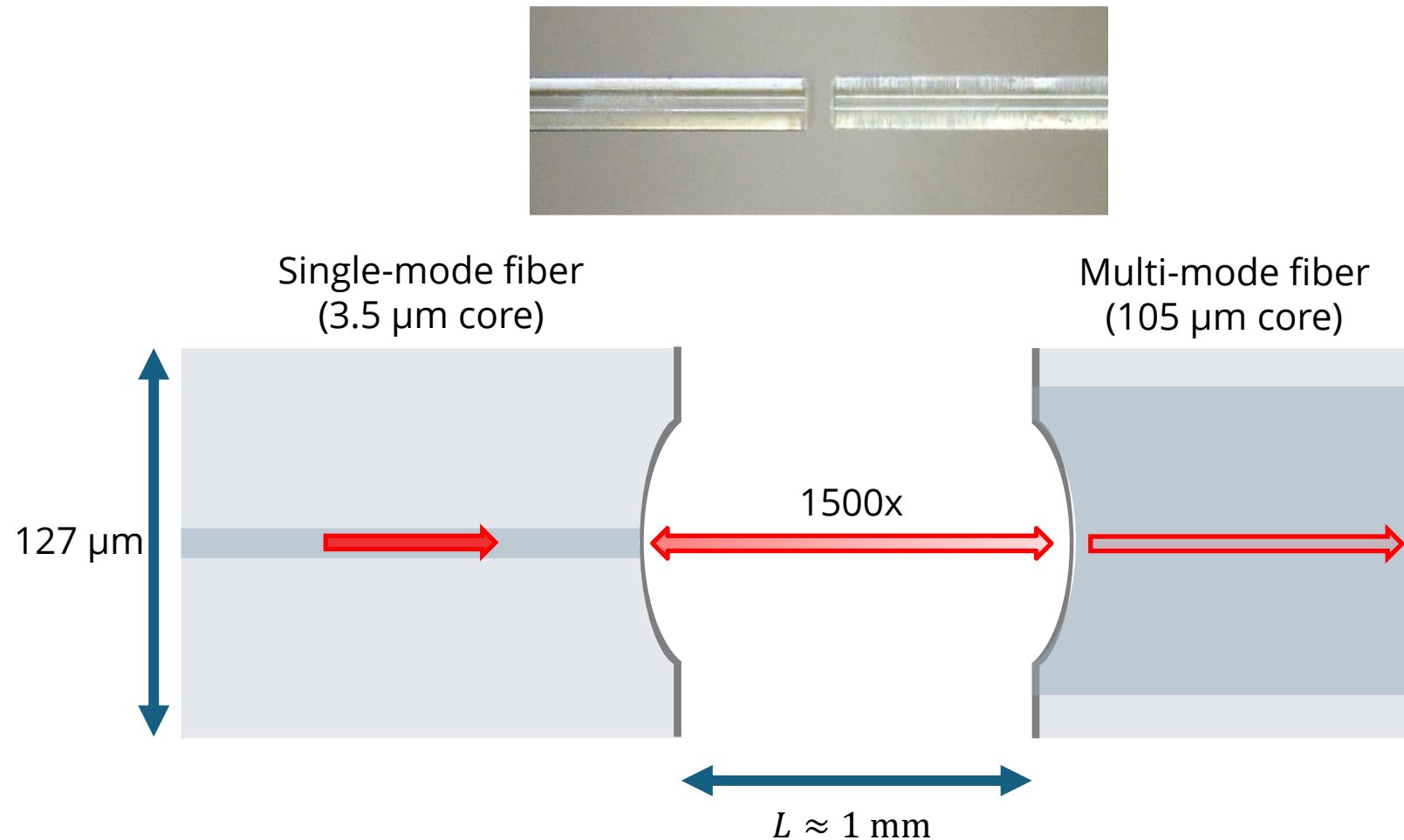

# Fabricating fiber micro-mirrors

- ▶ Ablate fiber end-facet with high-power CO<sub>2</sub> laser → spherical profile
- ▶ Coat with alternating layers of Ta<sub>2</sub>O<sub>5</sub> and SiO<sub>2</sub>

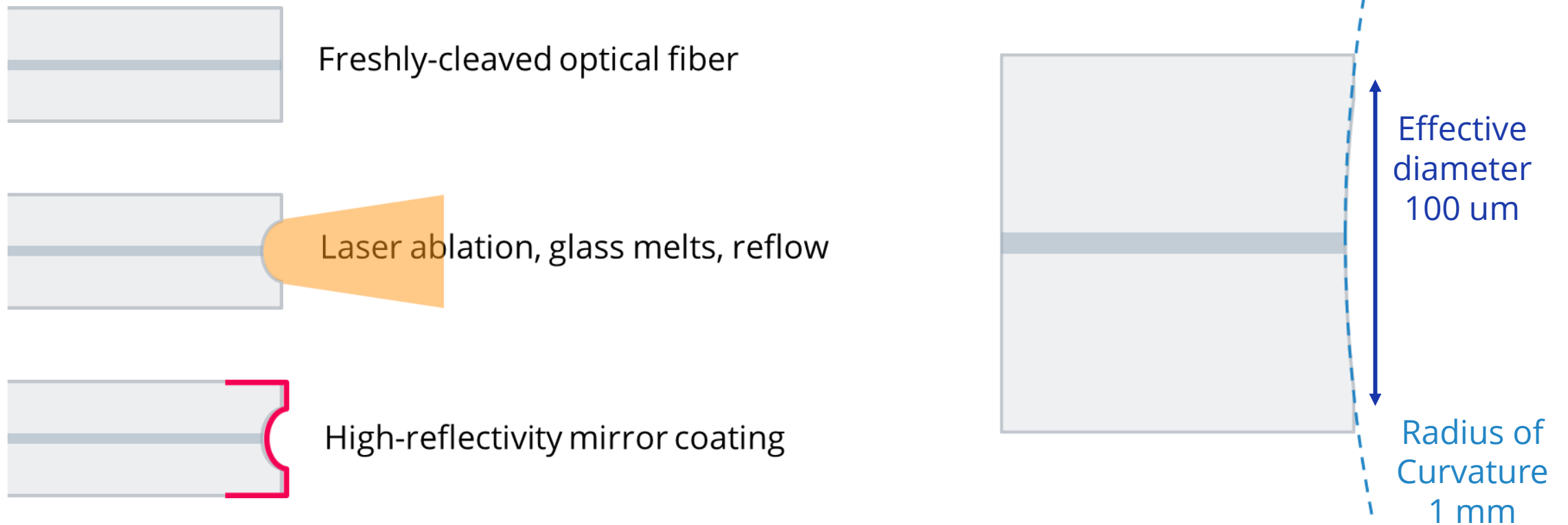

- ▶ Large ROC and diameter enable long cavity, better sensitivity

# Detector schematic

- ▶ Detector cavity separated from source and readout electronics by **20m of optical fiber**
- ▶ Active detection volume 13 pL

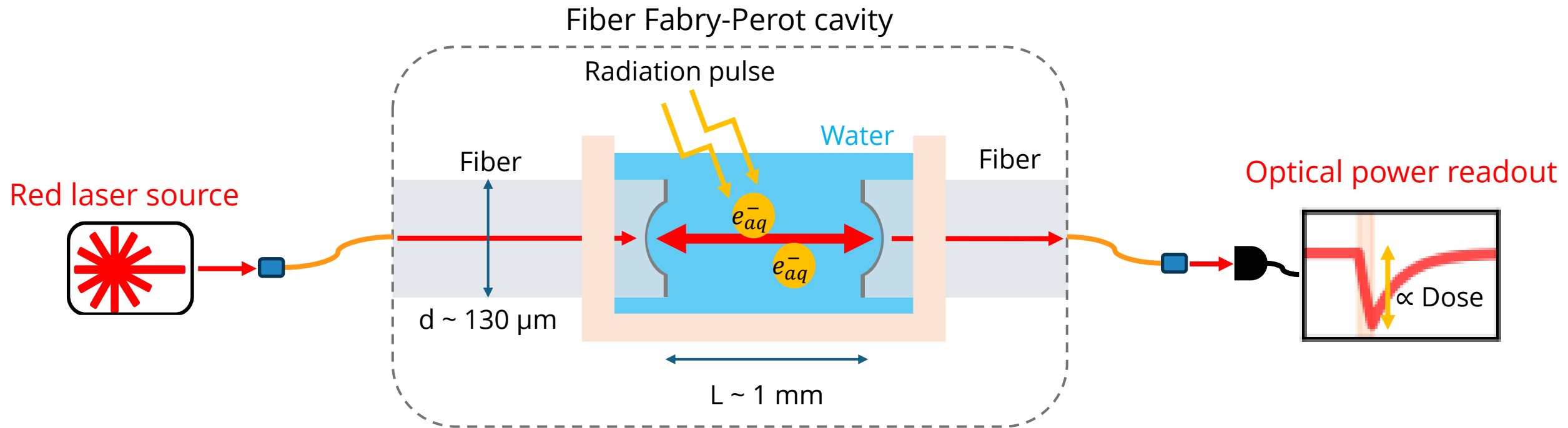

- ▶ Challenges: sensitivity to acoustic and mechanical noise, fluid handling

# Packaging - prototype design

- ▷ Orthogonal channel for fluid / gas handling

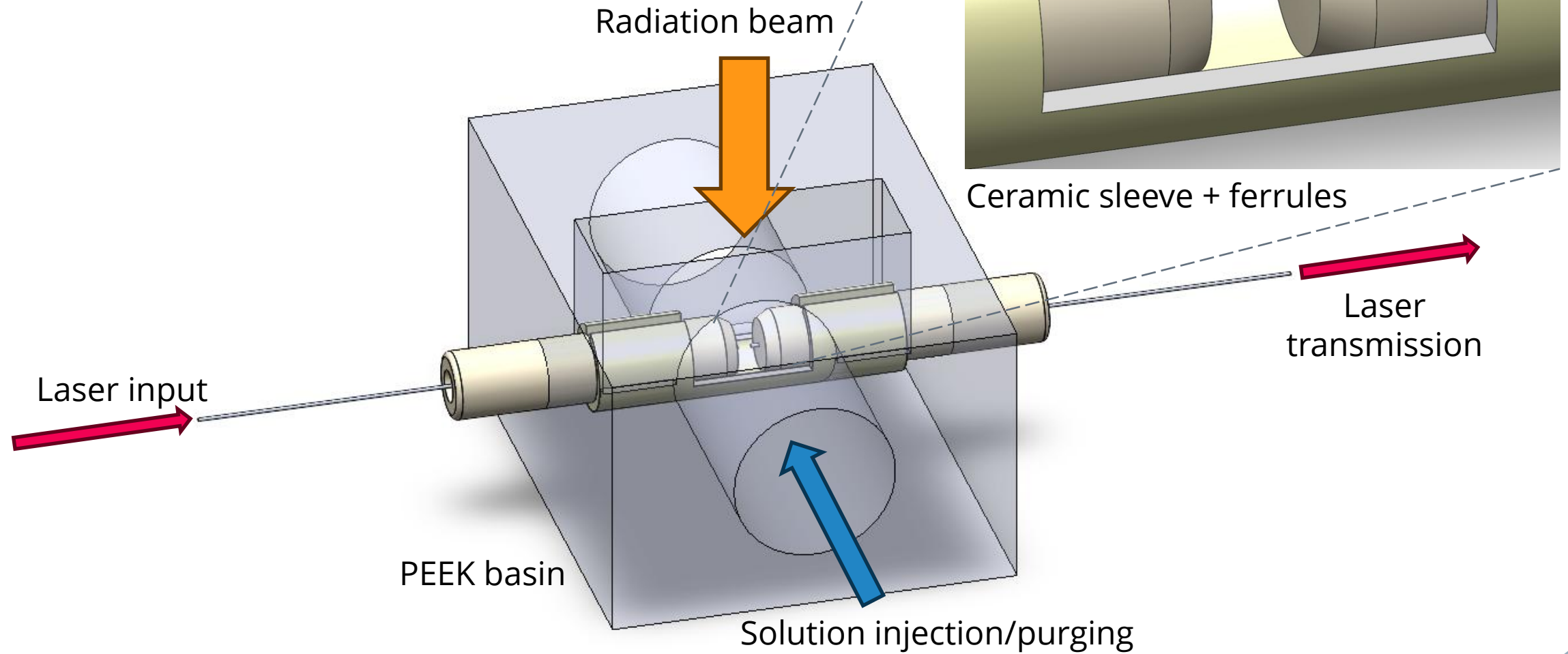

# Sensitivity predictions

- Expected signal amplitude modelled based on optical cavity characteristics

$$P(t) = P_0 \frac{4T_1T_2}{(T_1 + T_2 + \underbrace{2\alpha_w L}_{\text{Cavity absorption}} + 2\delta + \underbrace{2\alpha_e(t)L}_{\text{Hydrated electron absorption}})^2}$$

Mirror transmissivities

Cavity absorption

Hydrated electron absorption

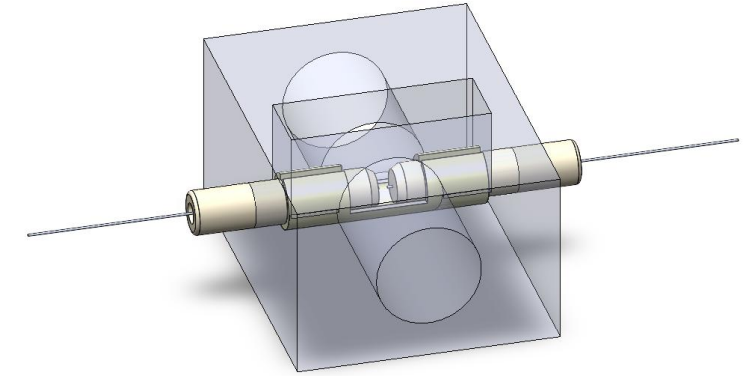

## Target cavity characteristics

Mirror radius of curvature	1000 $\mu\text{m}$
Mirror diameter	100 $\mu\text{m}$
Cavity length	1700 $\mu\text{m}$
Mirror transmissivities (symmetric)	0.25%

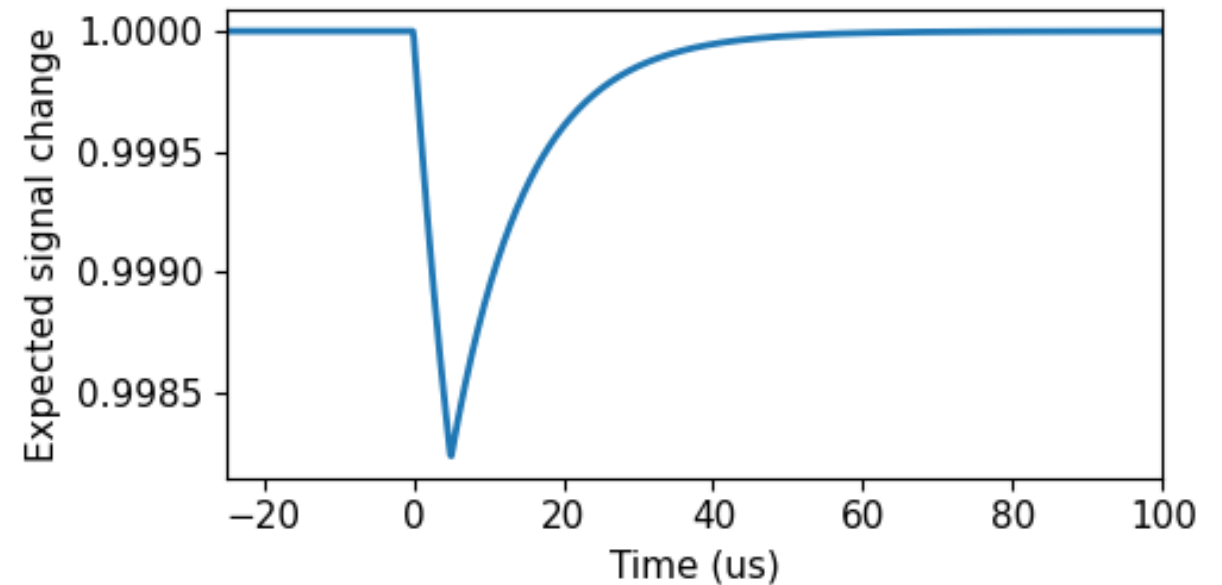

# Sensitivity predictions – considering noise

- ▷ Instantaneous sensitivity (“minimum detectable dose”)

$$D_{min} = \frac{\Delta V_{noise}}{\left| \frac{\partial V_p}{\partial D} \right|_{D=0}}$$

← Shot noise,  
Photodiode dark noise

## Target cavity characteristics

<b>Mirror radius of curvature</b>	1000 μm
<b>Mirror diameter</b>	100 μm
<b>Cavity length</b>	1700 μm
<b>Mirror transmissivities (symmetric)</b>	0.25%

## Sensitivity predictions

	Minimum detectable dose	Averages required (150 μGy)
<b>Shot-noise limited</b>	50 μGy	0

# Sensitivity predictions – considering noise

- ▷ Instantaneous sensitivity (“minimum detectable dose”)

$$D_{min} = \frac{\Delta V_{noise}}{\left| \frac{\partial V_p}{\partial D} \right|_{D=0}}$$

Shot noise,  
Photodiode dark noise,  
Laser classical noise,  
Acoustic/vibration-induced noise,  
...

## Target cavity characteristics

<b>Mirror radius of curvature</b>	1000 μm
<b>Mirror diameter</b>	100 μm
<b>Cavity length</b>	1700 μm
<b>Mirror transmissivities (symmetric)</b>	0.25%

## Sensitivity predictions

	Minimum detectable dose	Averages required (150 μGy)
<b>Shot-noise limited</b>	50 μGy	0
<b>10x shot-noise</b>	500 μGy	13

- ▷ Conclusion: ability to extract dose information from clinical (sub-mGy) radiation pulses

# Radiation dosimetry in fiber-optical cavities

A cavity-enhanced hydrated electron sensor for real-time, in-vivo, tissue-equivalent dosimetry

Tissue-equivalent medium

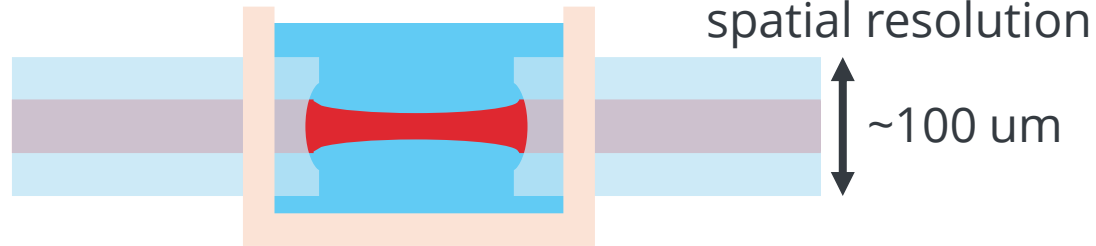

Fiber-optical readout



McGill QS lab



**Thank you!**

Acknowledgements:

Fernanda C. Rodrigues Machado, Jingyi Bian, Michael Caouette-Mansour  
Tanner Connell, Bhavan Siva, David De Longchamp,  
Shirin Enger, Lilian Childress, Jack Sankey

