

Impact of Nickel Cryostats in the nEXO Detector

Antoine Amy, Julien Masbou, Andrea Pocar

October 10th 2024

nEXO Collaboration

1. The nEXO Experiment
2. Cryostat Vessels: From Carbon Fiber Composite (CFC) to Nickel
3. HFE Shielding
4. Design Implications

$0\nu\beta\beta$ =new physics

- Lepton number violation
- Explores neutrino nature and mass hierarchy
- Could explain matter-antimatter asymmetry

^{136}Xe decay signature at 2458 keV, requires:

- Good energy resolution ($< 1\% \sigma E/E$)
- Large mass of enriched isotope (5 tons of 90% ^{136}Xe)
- Low background (< 0.5 counts/y/2t/ROI)

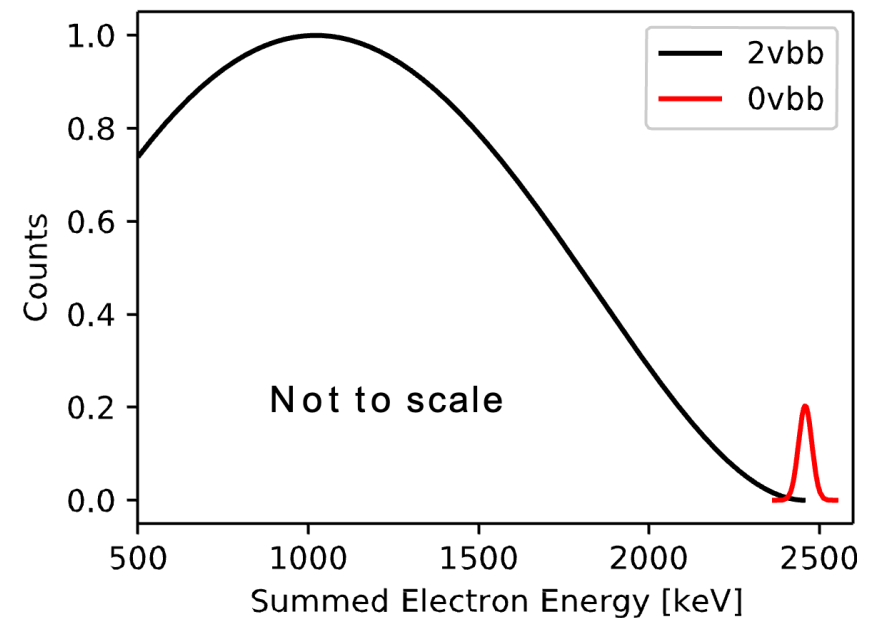
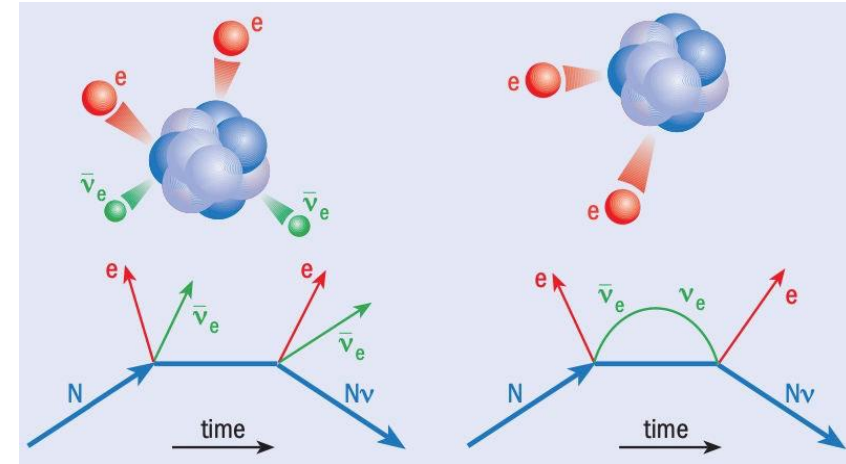

The nEXO Experiment: A Large Unexplored Parameter Space

nEXO=New $0\nu\beta\beta$ Detector Generation

- EXO-200=previous generation
 - Was a success
 - Discovery of $2\nu\beta\beta$ decay of ^{136}Xe
- nEXO will have a limit x100 better than the current best experiment

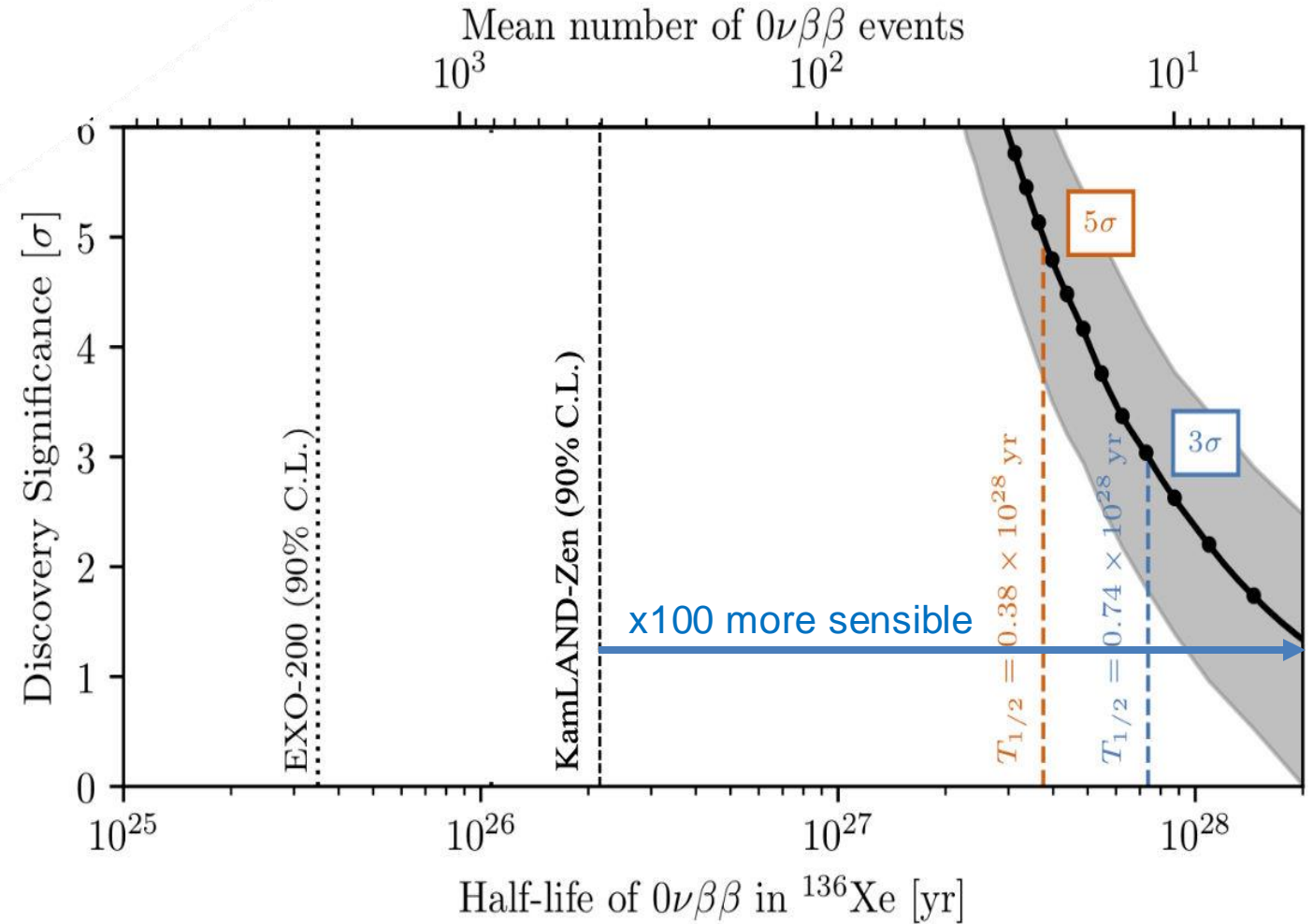

The nEXO Experiment: A World Wide Effort

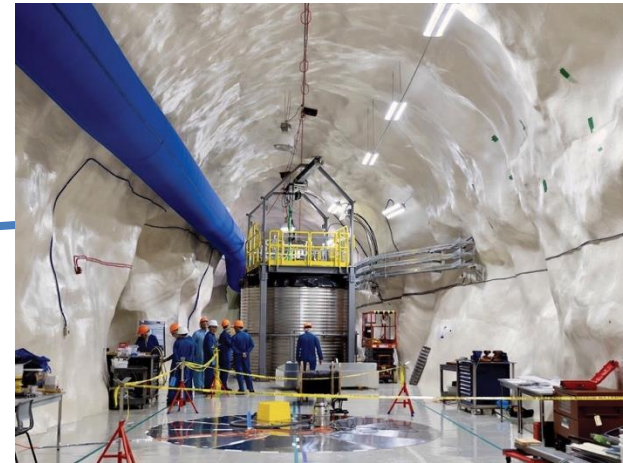

SNOLAB, Canada

9 countries, 34 institutions, ~200 collaborators



Detector's Geometry: Multi-Layer Shielding

- @ SNOLAB, 6000 m.w.e (2500 m more than Gran Sasso)
- Big volume of water: Active muon veto
- Dual cryostats: Vacuum insulation barrier
- 32 tons HFE*: Gamma/neutron shield + cryo stability
- Radiopure copper Single Phase TPC
- 5 tons 90% Liquid ^{136}Xe at 165K

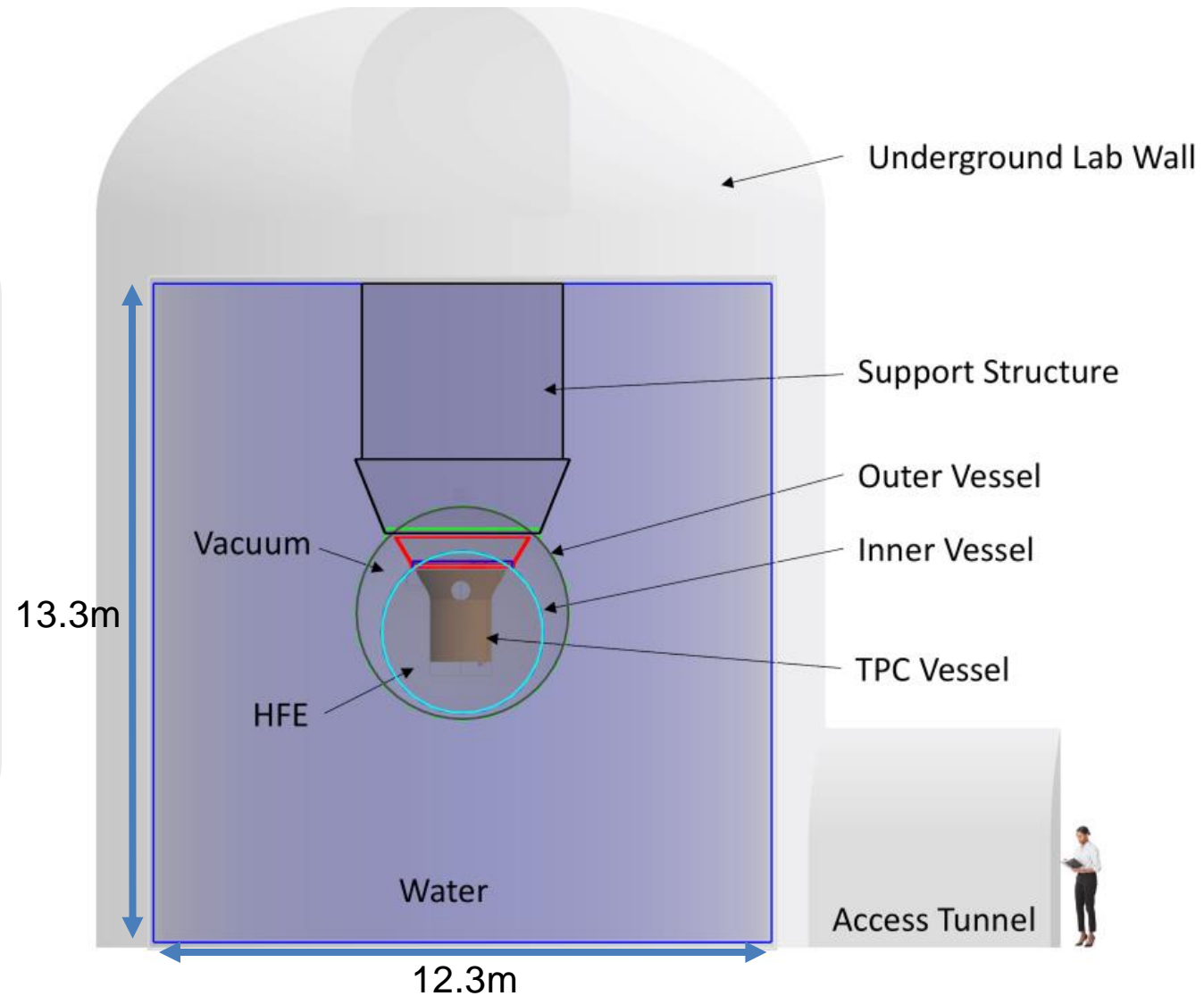

Signals Generation & Detection

- Xenon is both the source and detection medium
- Ionizing radiation produces:
 - prompt scintillation (S1) 175nm UV photons → immediately detected by SiPMs around the barrel
 - Ionization electrons (S2) → drifted to charge collection tiles at the top

Signals Analysis

- Dual signal enables 3D event reconstruction
- Multiparameter identification to differentiate with γ , μ ,... background

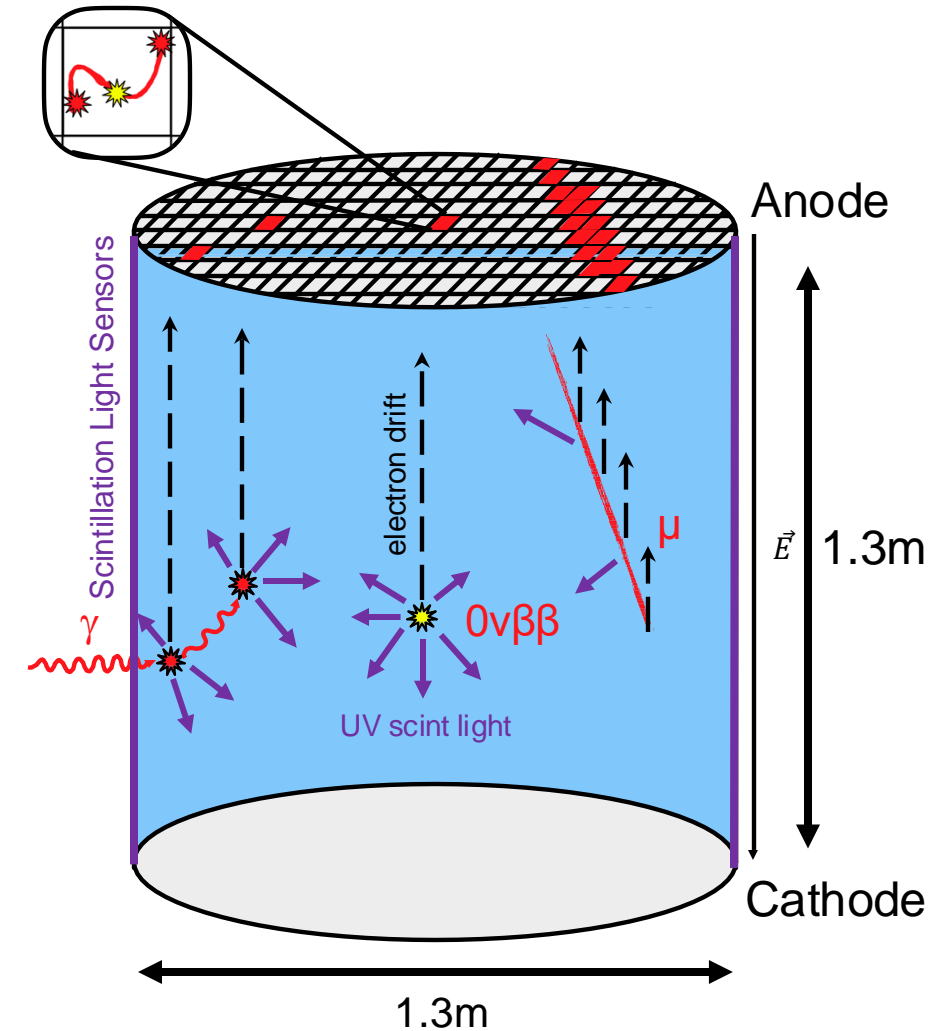

Selection Criteria

- Energy in the FWHM of the $0\nu\beta\beta$ ROI
- In the inner 2 tons of LXe*
- Single Site: Neural Network > 0.85

Energy: *Signal like*

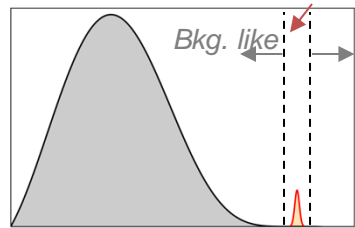

Standoff:

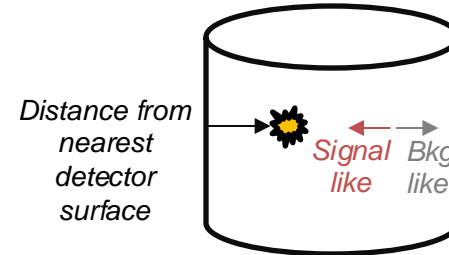

Topology:

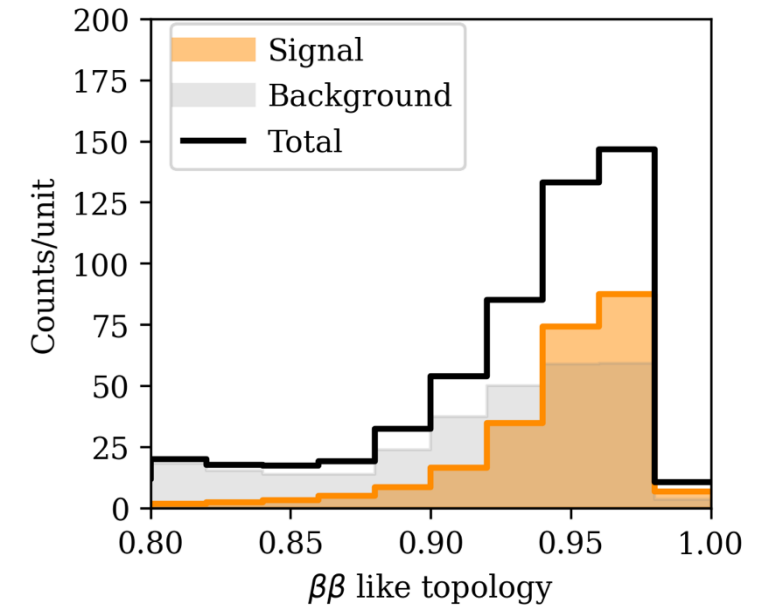
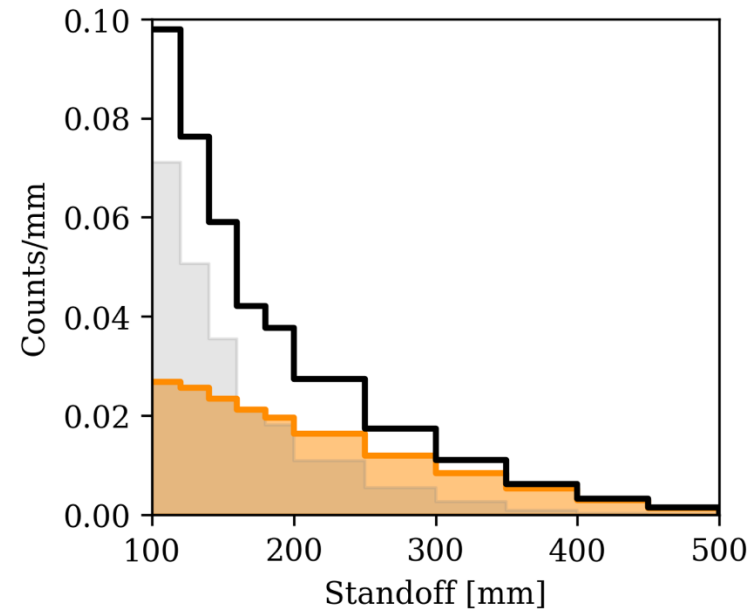
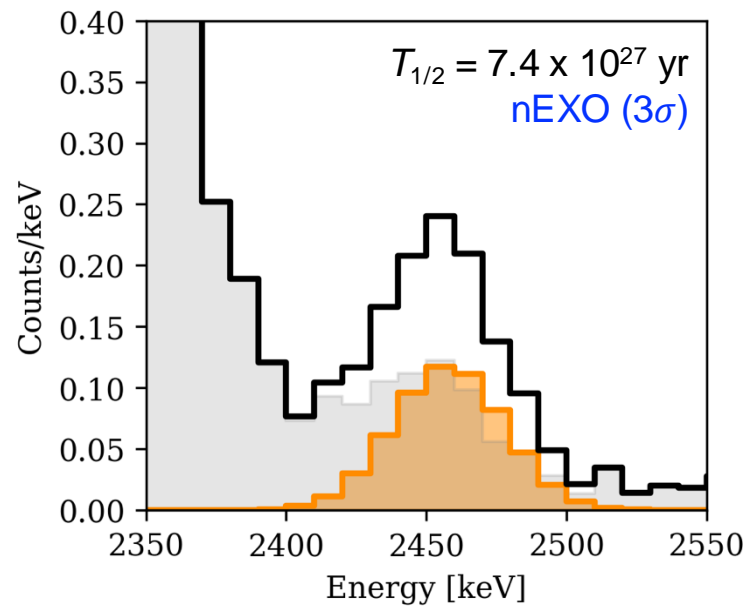
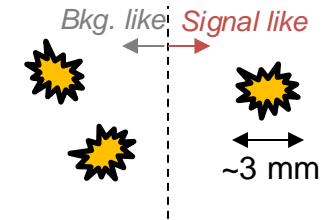

*: As a reference. Weighted by spatial probability distribution. No hard fiducial cut applied.

Expected Sensitivity

- A large unexplored parameter space
- Reach a half-life of 10^{28} years in 6.5 years data taking
- x1000 more sensible than the previous generation (EXO-200)

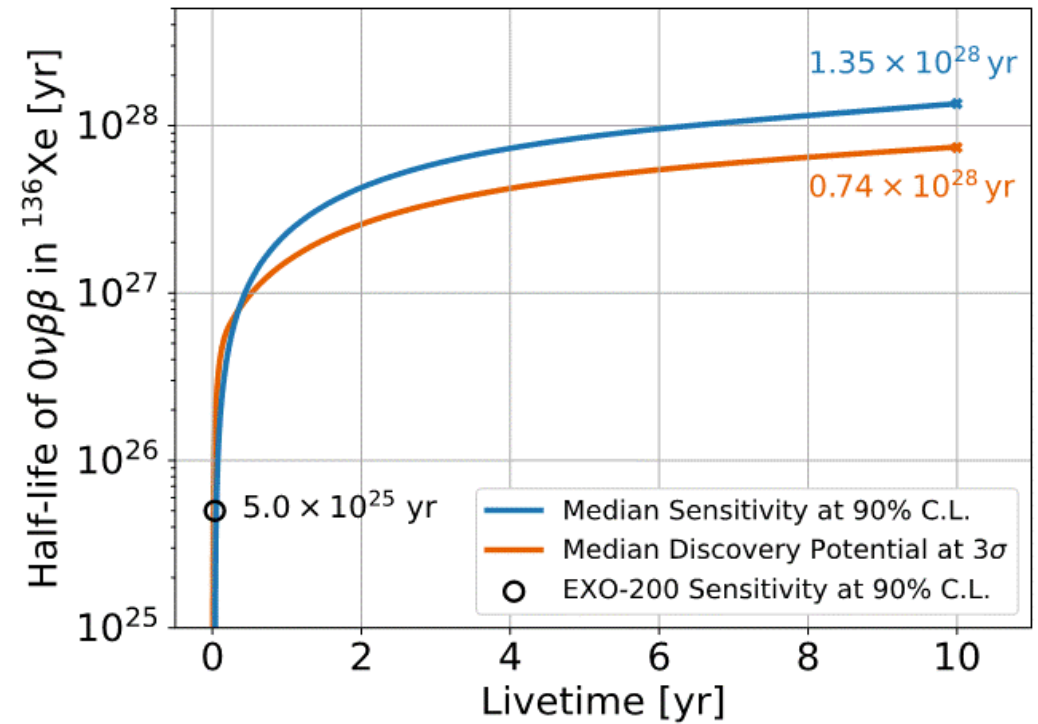
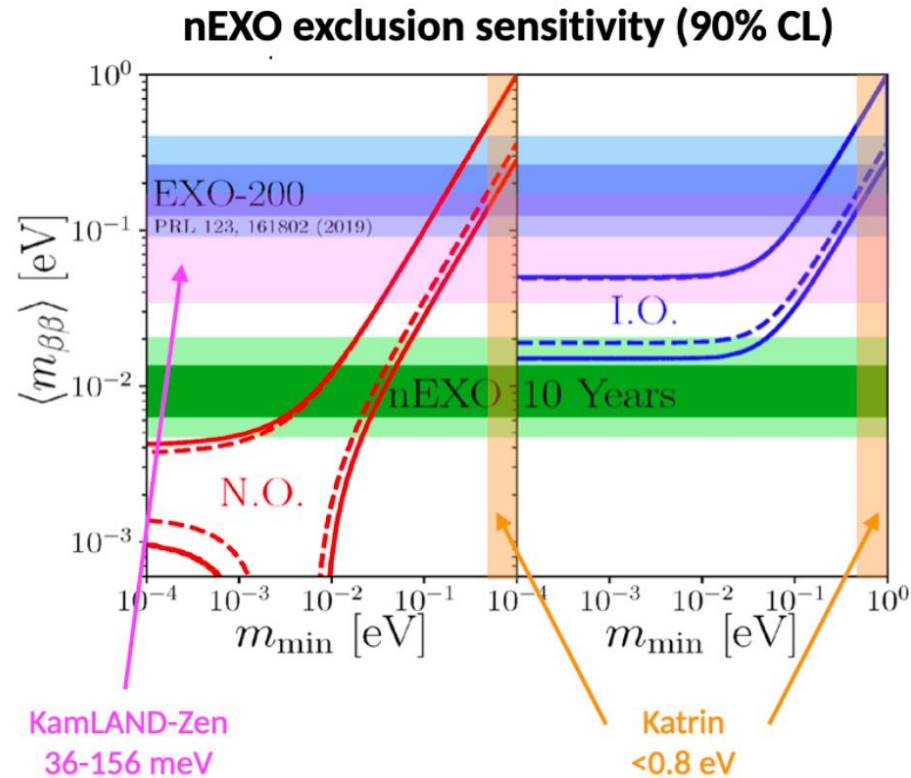

Internal Background Sources

- Mainly from to γ -rays emitted by decaying nuclides
- From: ^{232}Th (mainly ^{214}Bi : 2615 keV*)
 ^{238}U (mainly ^{208}Tl : 2448 keV)

Component Background Contribution

$$B = B_U + B_{Th} = m \times (a_U \times \epsilon_U + a_{Th} \times \epsilon_{Th})$$

m : component's mass

a : component's material activity

ϵ : component's hit efficiency

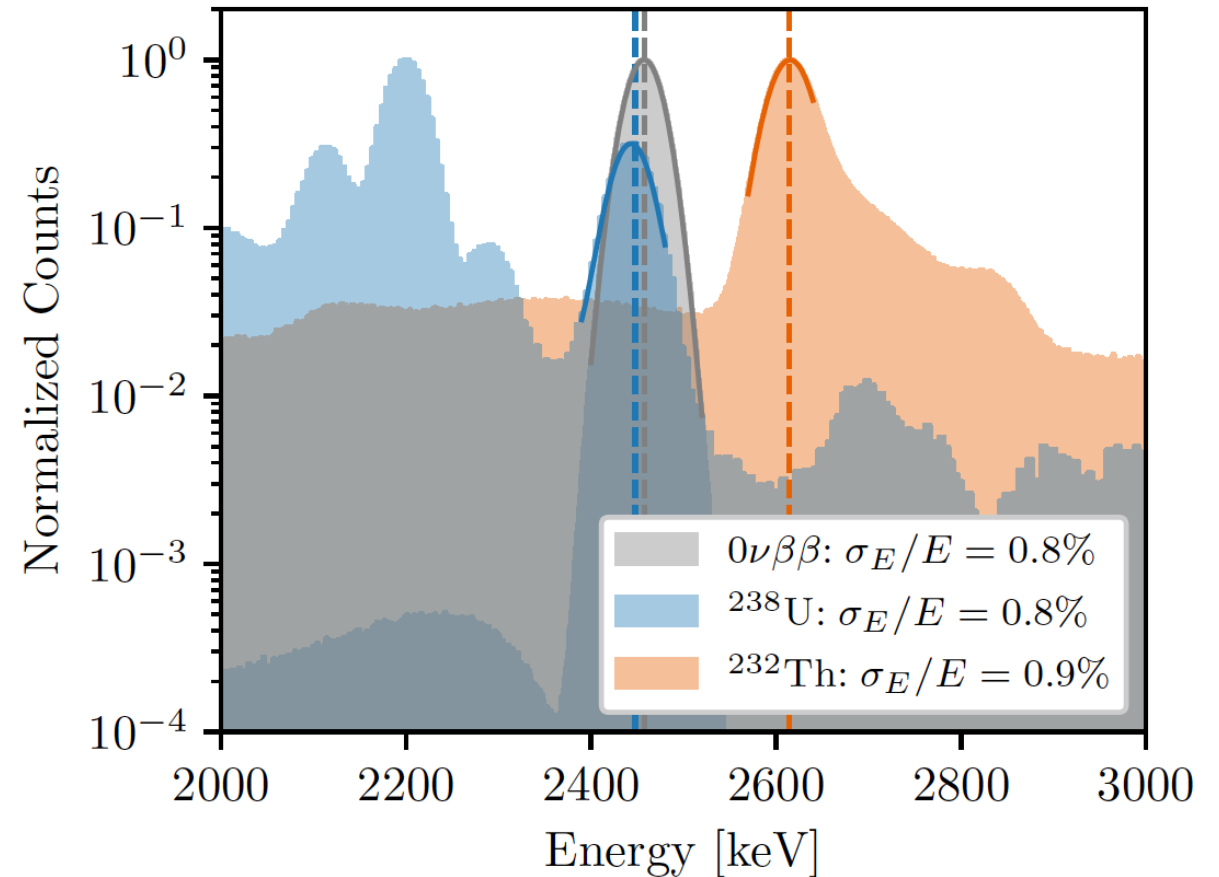

Hit Efficiency Definition (ϵ): The probability of a decay event becoming a background count

*: then soft Compton in HFE to get in ROI

Why use Nickel instead of CFC (previous plan)?

- Cryostat Vessels are prominent internal background sources
- Searched for new ultra radiopure material: low-activity Nickel samples
- Background contribution reduction of a Factor ~ 300
- Nickel=new baseline for the cryostat vessels

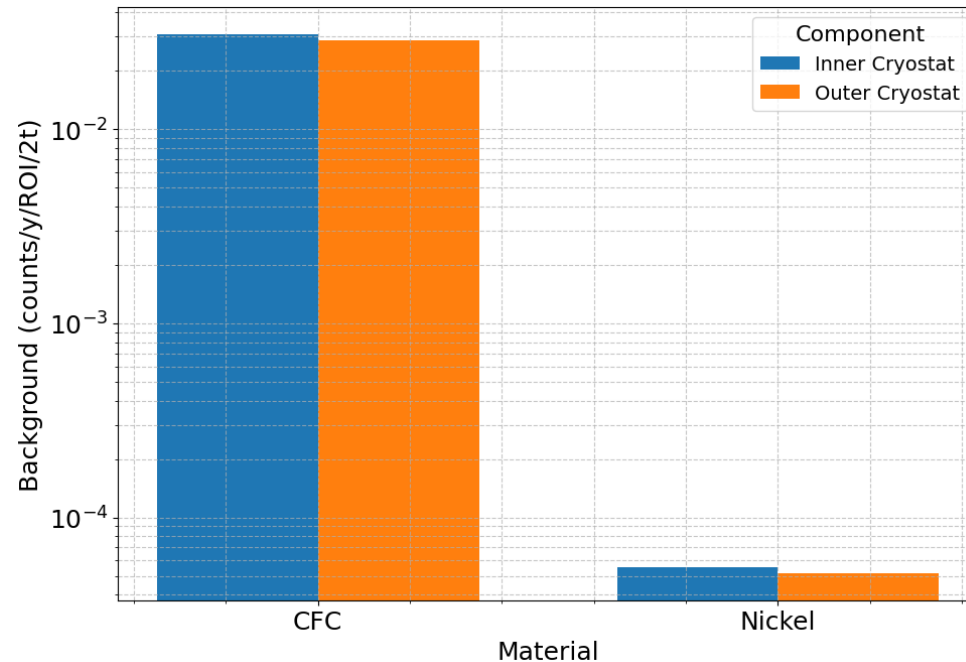

Cryostats Design Values (for now)

- Inner Vessel (IV) radius: ~ 1.7 m
- Outer Vessel (OV) radius: ~ 2.2 m
- HFE-7200 mass: 32 tons

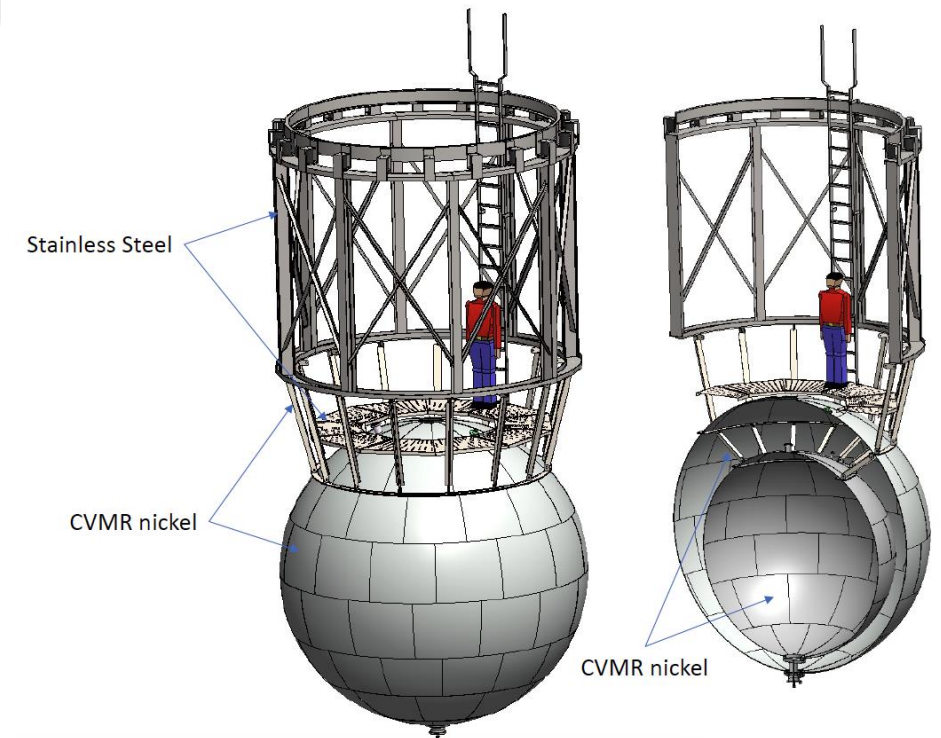

Motivations to Use a HFE-7200 Bath

- Dense liquid at room & cryo. temperatures
 - Efficient γ -ray shield
- Highly radiopure material
- Ensures cryogenic system stability at 165K

Baseline Dimensions of the HFE Bath

- **Min. Thickness: 76 cm** (for 1.7 m IV)
- Center to TPC corner: 90 cm

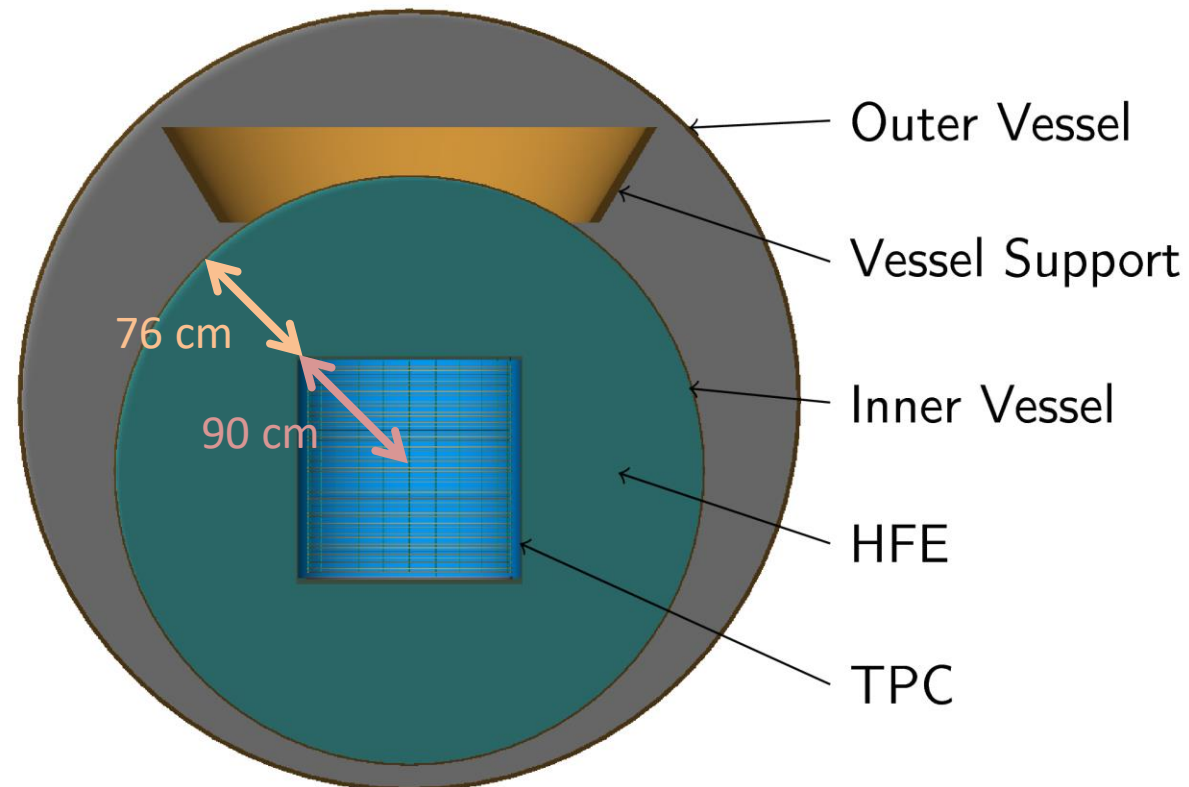

Vessel materials less radioactive → Possibility of reducing HFE thickness (while keeping the same background contribution)

Testing with Less HFE

- Using Geant4: $1e10$ ^{214}Bi & ^{208}Tl decays
 - Decays in cryostat vessels
 - Testing multiple IV radii* (from 1.7 \rightarrow 1 m)
 - Reconstruction with Strax
 - Neural Network still in development; initial preliminary results only

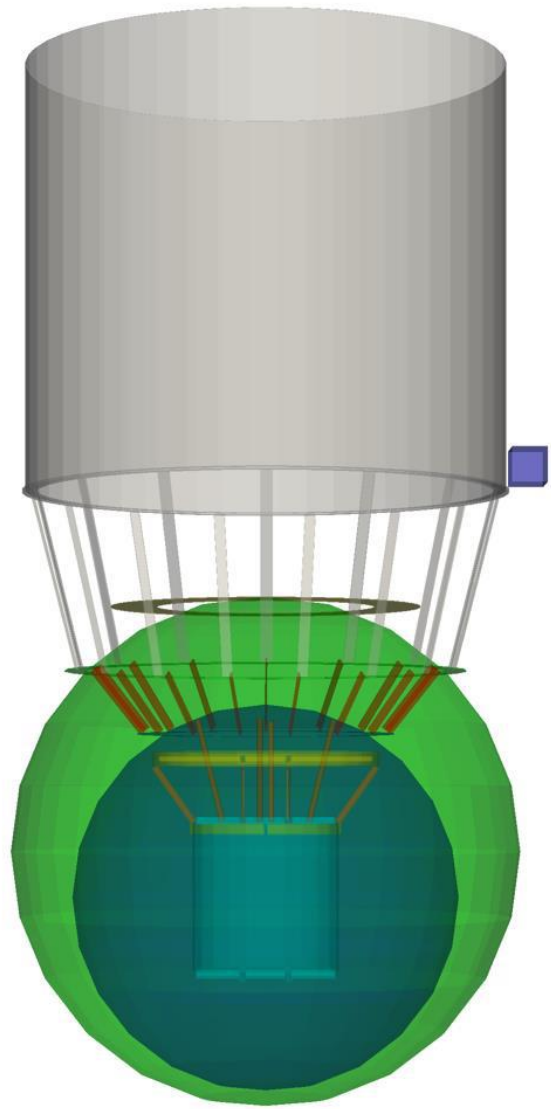
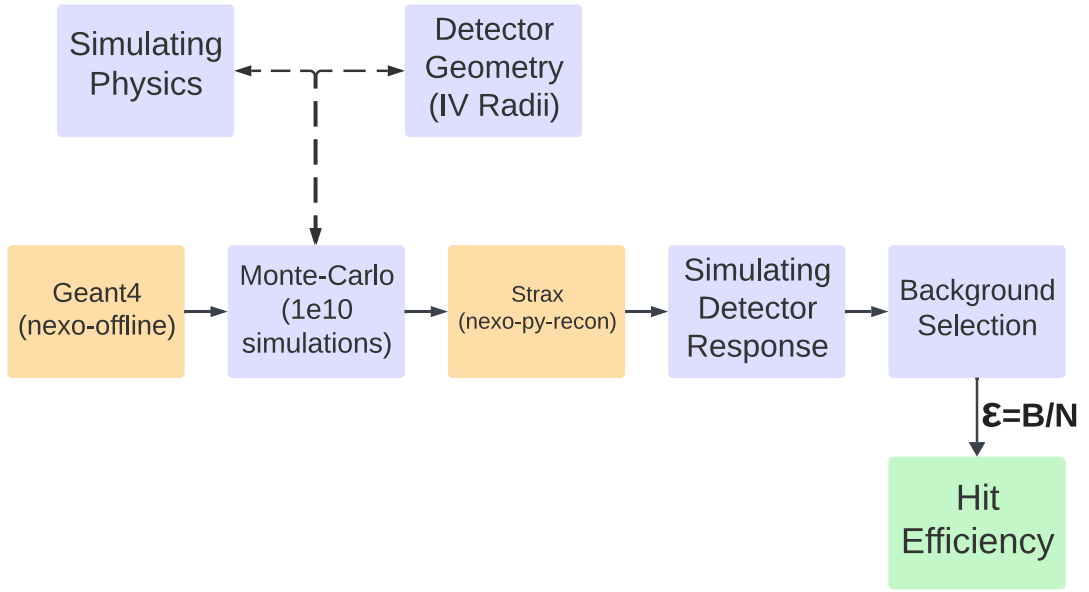

Geometry in Geant4

*HFE volume adjusted accordingly

Vessels Hit Efficiency vs HFE Thickness

- Cross-checked with previous studies
- Exponential evolution (expected with attenuation law)

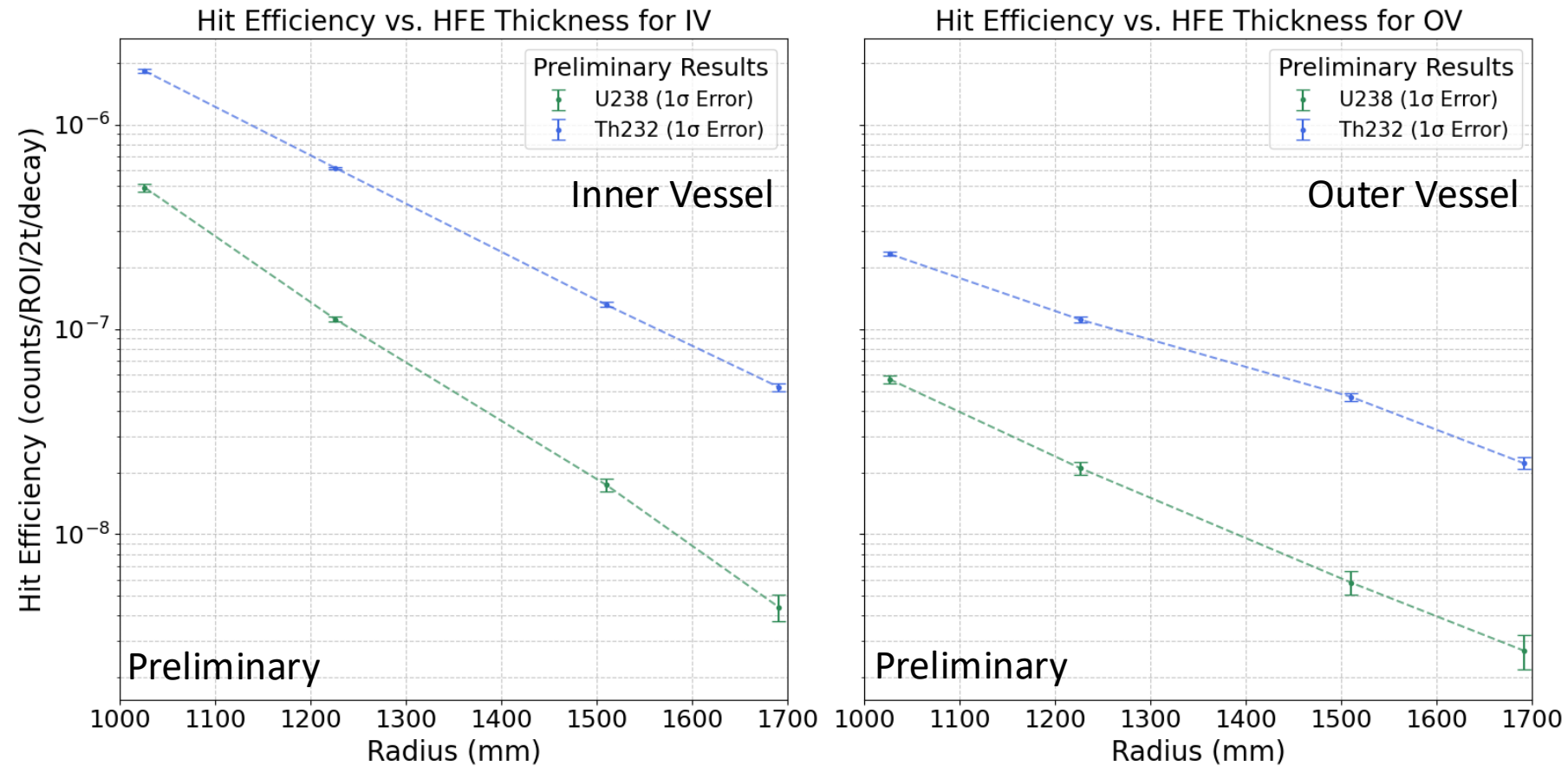

IV Background Contrib. vs HFE Thickness

- Sum of ^{232}Th & ^{238}U contributions
- Activities measurements from Ni. samples
- Same procedure will be done for OV (after finalized Neural Network)

CFC to Nickel Background Equivalent

- IV bkgd budget: 0.032/y/FWHM/2t
- IV radius 1.7 m \rightarrow 1.125 m

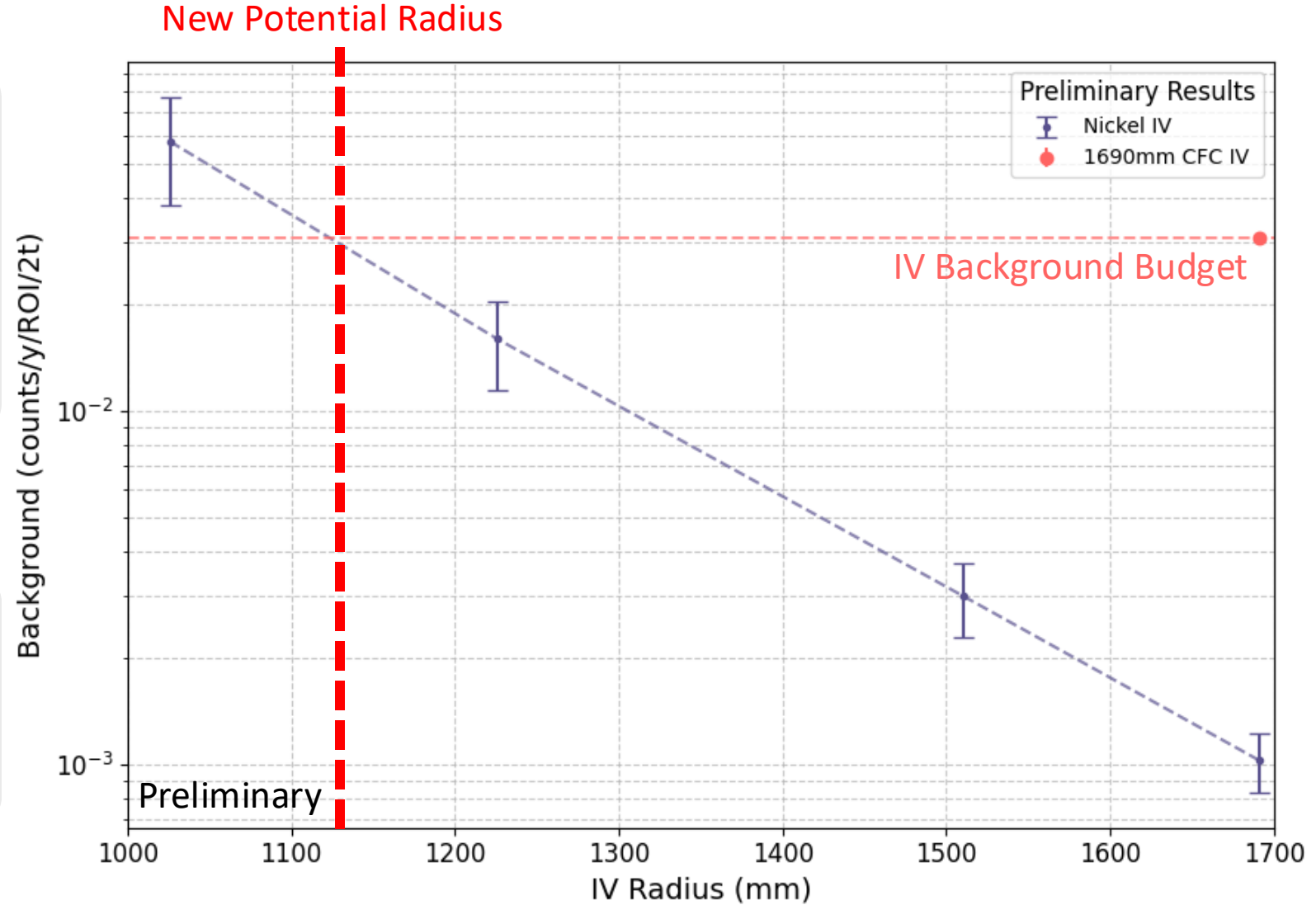

Reducing HFE Shielding

- Assuming IV Radius : 1.125 m
- Less HFE = Less storage needed, more space available
- Cost reduction

Possible Reductions (Radioactivity Only)

- ▼ Mass: 32 → 7.5 tons (price ~/4)
- ▼ Volume: 18.5 → 4.4 m³
- ▼ Min. thickness: 76 → 25 cm

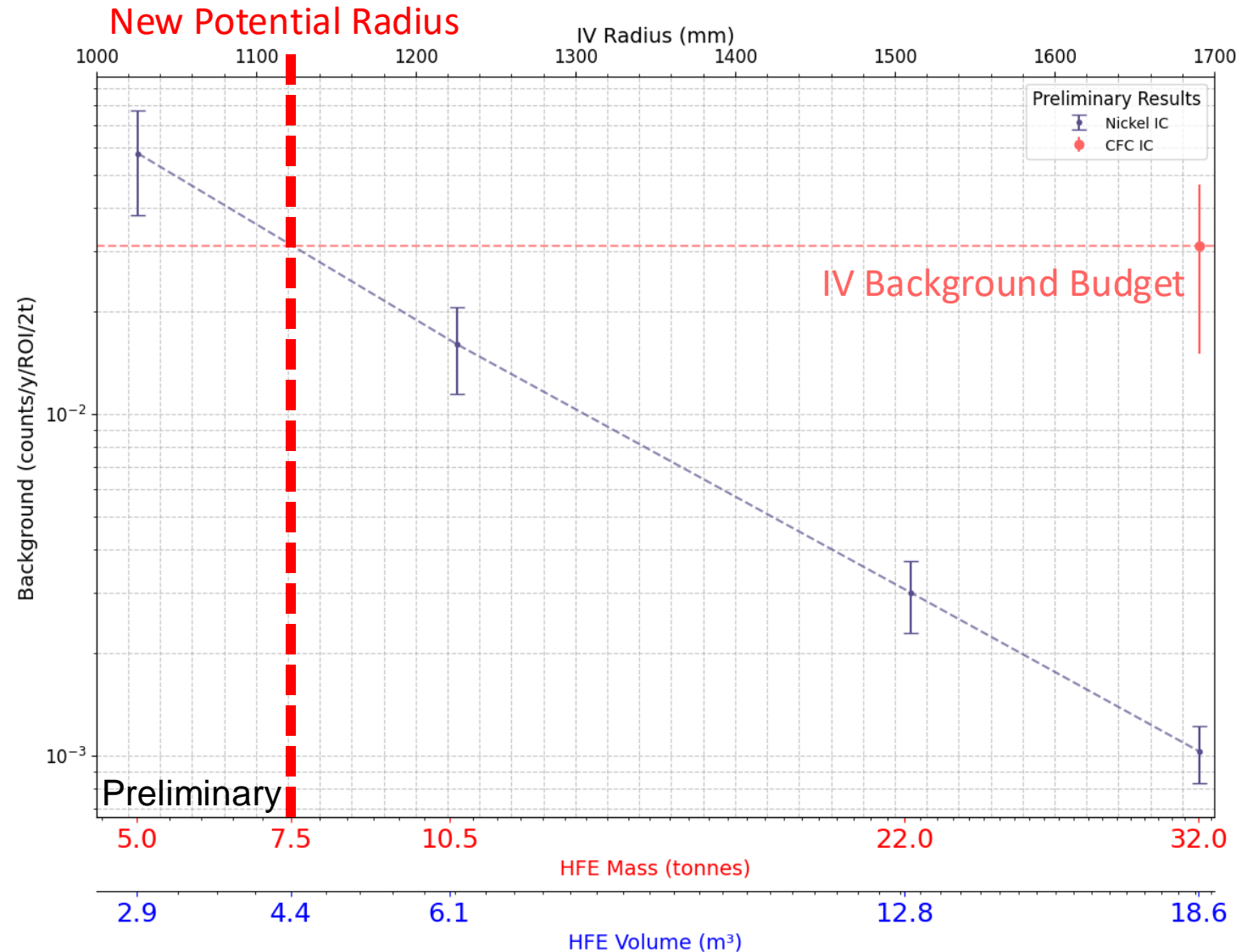

Less HFE = External Background Increased

- From OV, ^{222}Rn from water, ...
- Can be quantified with the attenuation law (before MC results)

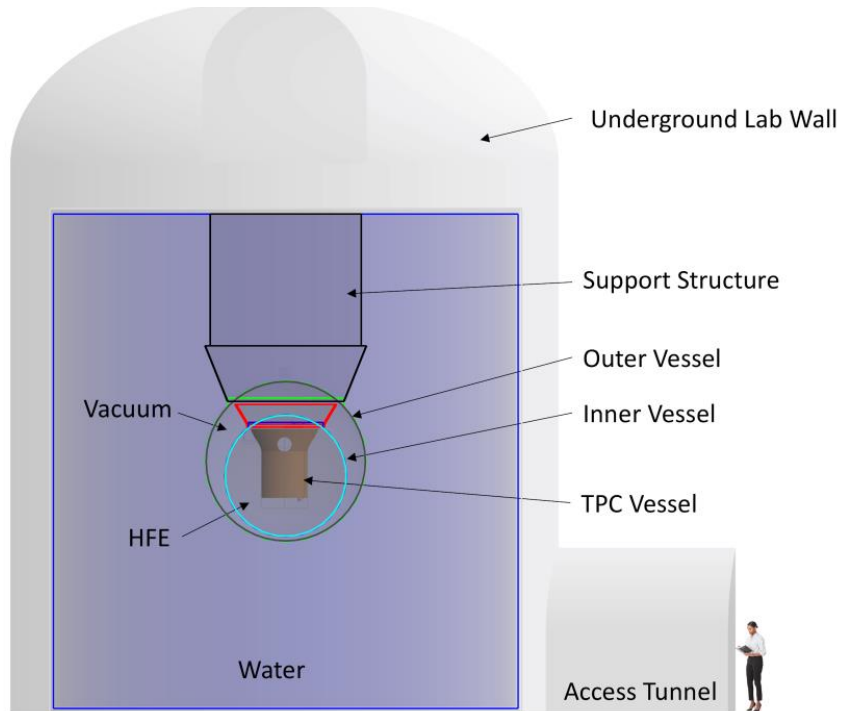

Min. HFE Thickness 76 → 25 cm means

- ▼ Shielding efficiency /30 \Leftrightarrow External radioactivity: 30x greater impact
- ▼ Maximal allowable radon concentration decreased*
- 25cm target, to be adjusted based on external background levels

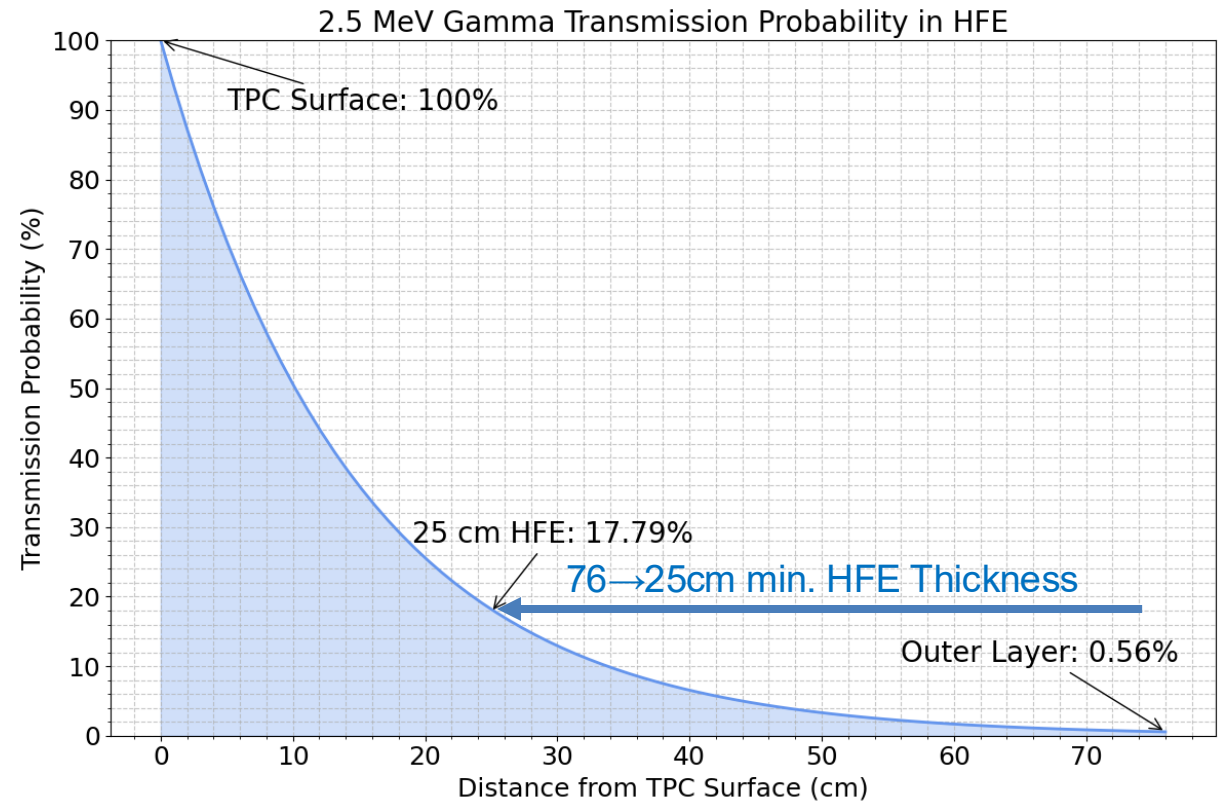

*Potential for optimal HFE vessel size balancing radon background vs. HFE quantity

HFE Cold Mass Reduction

- LXe needs to stay stable at 165K
- Still the largest cold mass: 5x more than LXe
- ▼ 4x less HFE = 4x less HFE cold mass

Component	Mass (tons)	Energy for 1K rise (MJ)
LXe	5	2
HFE (baseline quantity)	32	40
HFE (reduced quantity)	7.5	10
Cryostat IV (Ni)	2	1
Total (reduced HFE)	14.5 tons	13 MJ

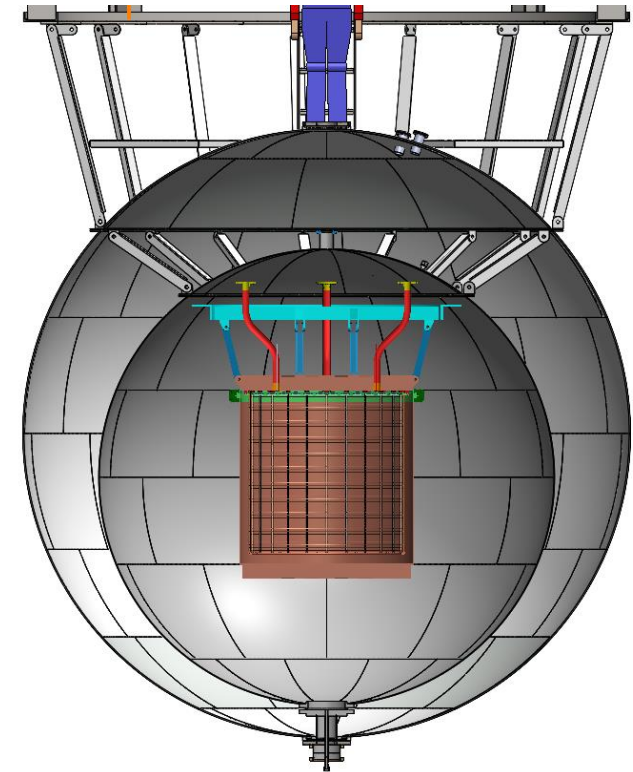

Main Message (using Nickel)

- Radioactivity: 300x better than CFC
- IV radius could be reduced: 1.7 → 1.125 m*
- HFE is still the main cold mass

Outlook

- Other components background impact
- Thermal mass inertia study
- Mechanical study necessary

Implications Discussed

Impact	Pros	Cons
Economic	HFE cost reduction (32 → 7.5 tons)	
Spatial	Reduced storage requirements	
Design	Cryostats easier to build	
	Potential thinner IV & OV	Redesign requirements
	Possibility to increase water shielding	More radon from water
Operational	Faster cooling time	Reduced cold mass

*i.e. Min. HFE thickness: 76 → 25 cm

Backup

Space Required

- Around 5000 m³ total
- 3500 m³ needed for the Veto Tank

nEXO installations at SNOLAB

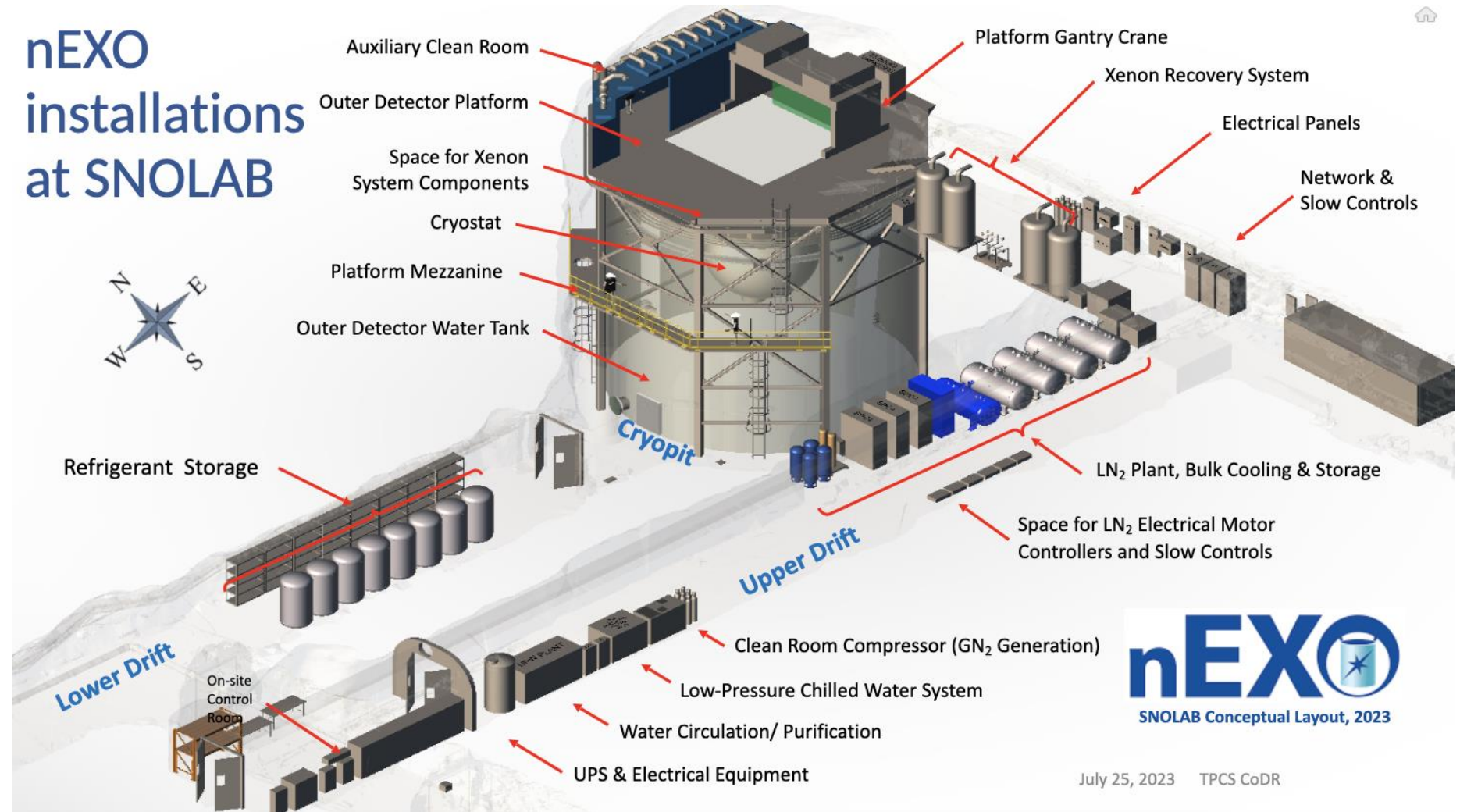

July 25, 2023 TPCS CoDR

Signals Generation

- Ionizing radiation will either ionize or excite Xe atoms
- Xenon is both the source and detection medium

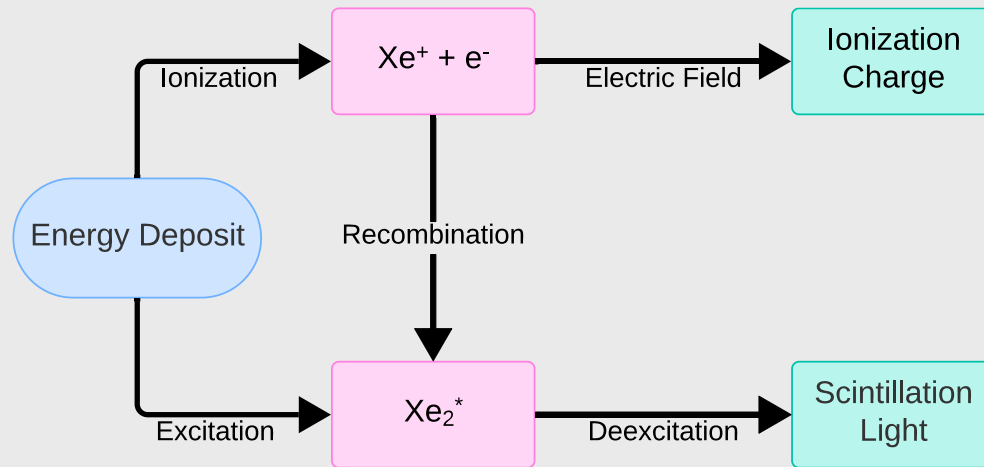

Signals Detection & Analysis

- Photons immediately detected by SiPMs around the barrel
- Electrons drifted to charge collection tiles at the top

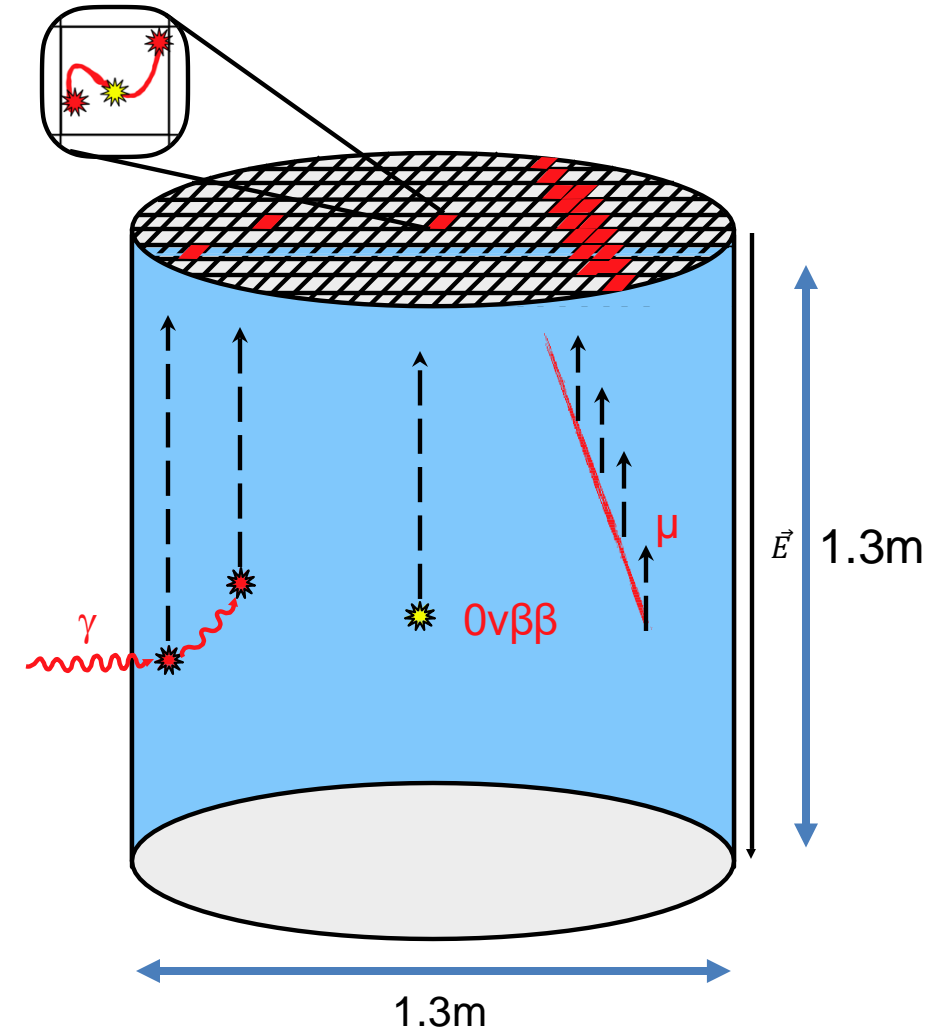

Charge Collection Tiles

- Electrons are drifted to charge collection tiles at the top
- 10cm x 10cm charge collection tiles with 3mm pitch strips detect e⁻

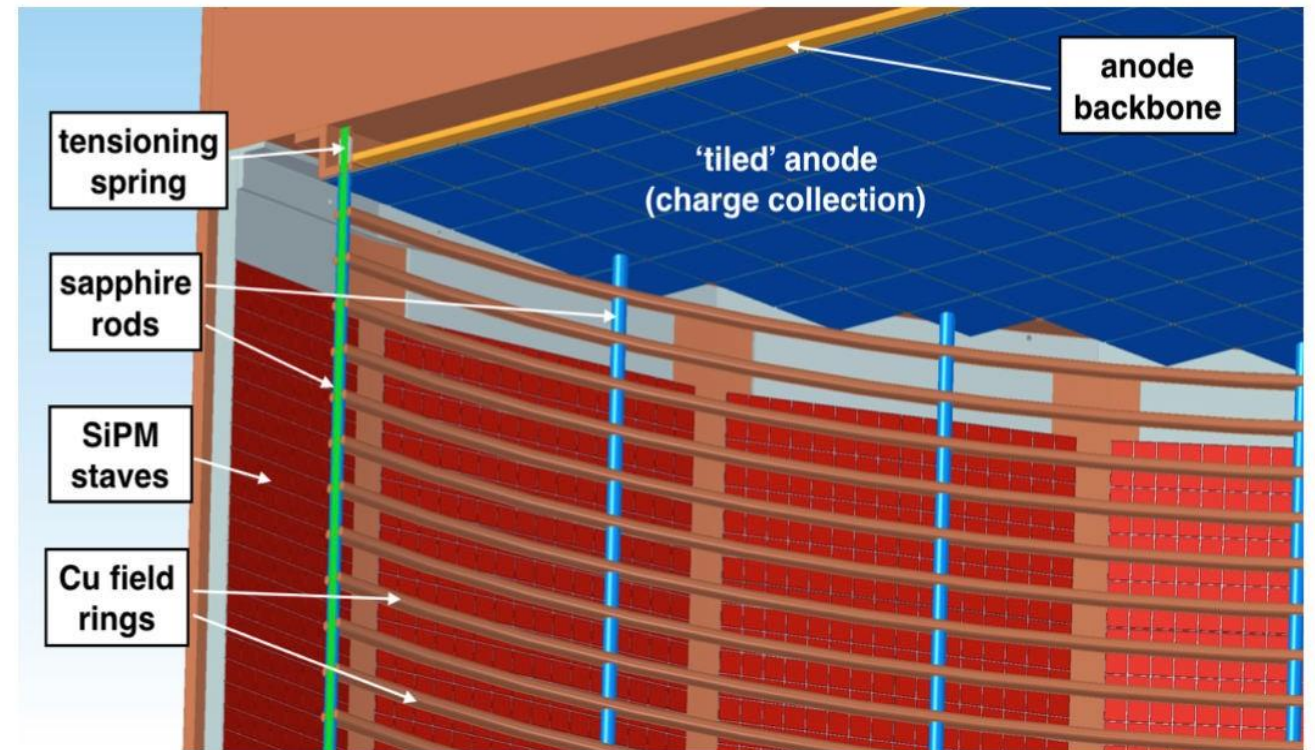
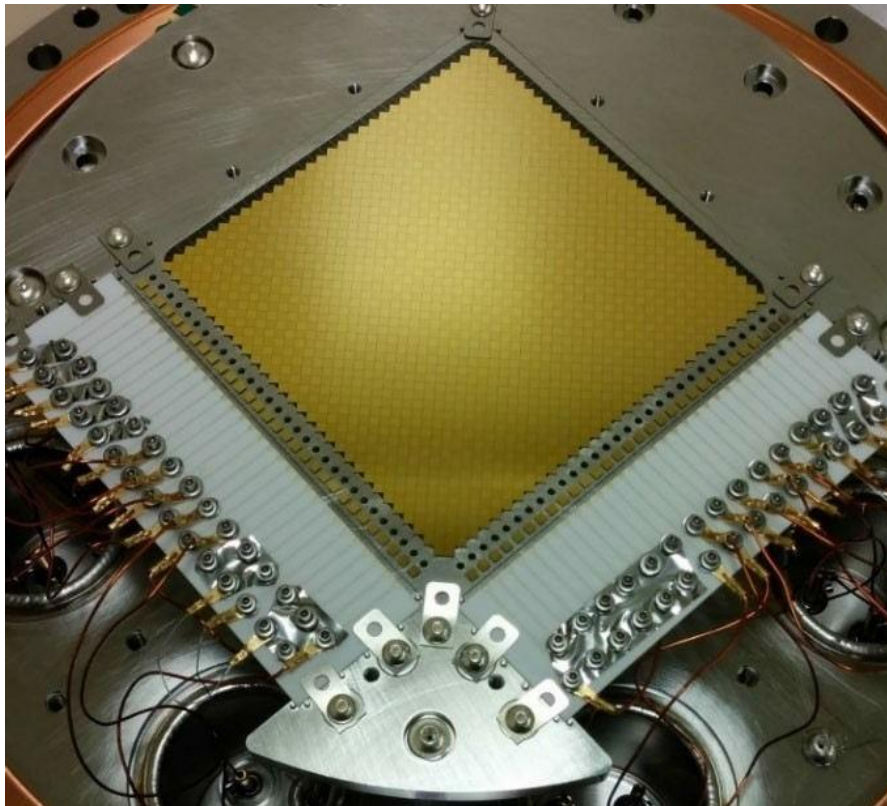

Selection Criteria

- Energy in the FWHM of the $0\nu\beta\beta$ ROI
- In the inner 2 tons of LXe*
- Single Site: Neural Network > 0.85

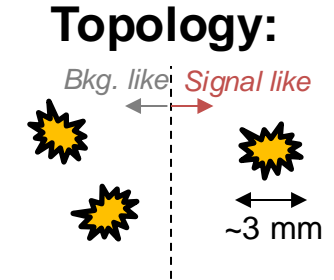
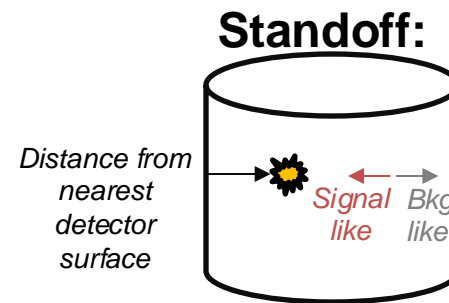
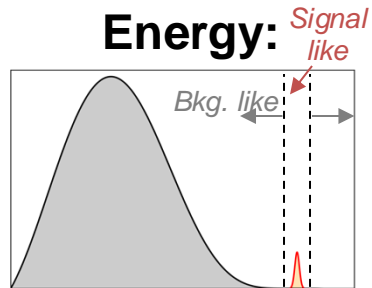

3D bins ordered by S/B in 1D: Visualizes signal-background separation while preserving correlations

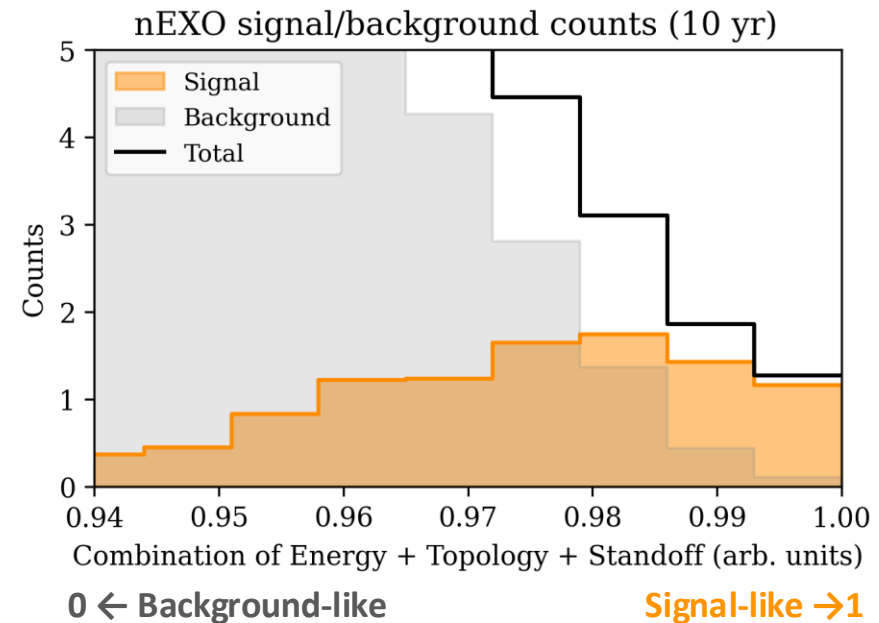

*: As a reference. Weighted by spatial probability distribution. No hard fiducial cut applied.

Other Sources of Background

- CFC Cryostat Vessels were a dominant internal background source
- Other backgrounds now play a more prominent role

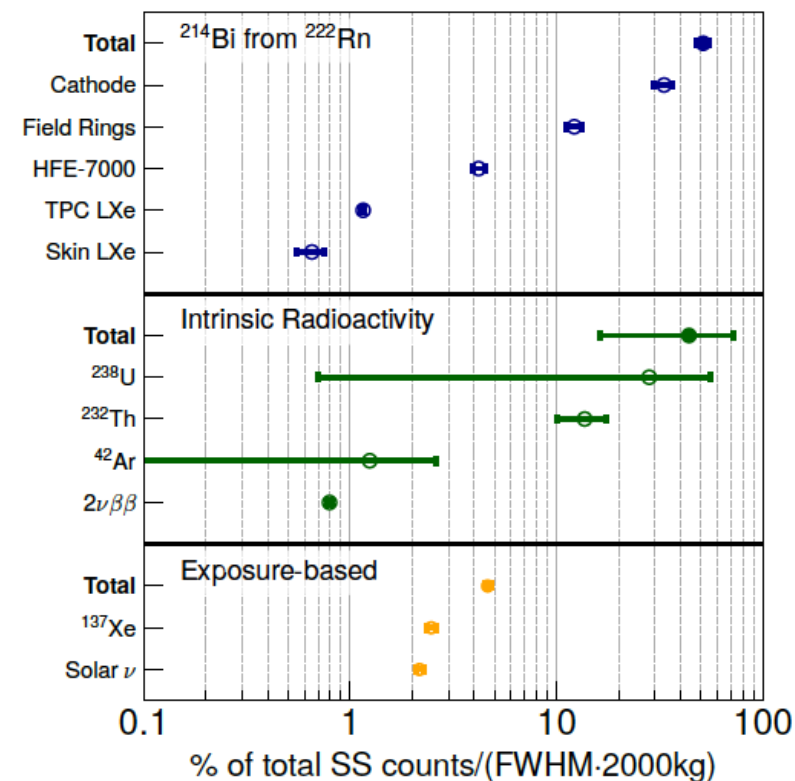
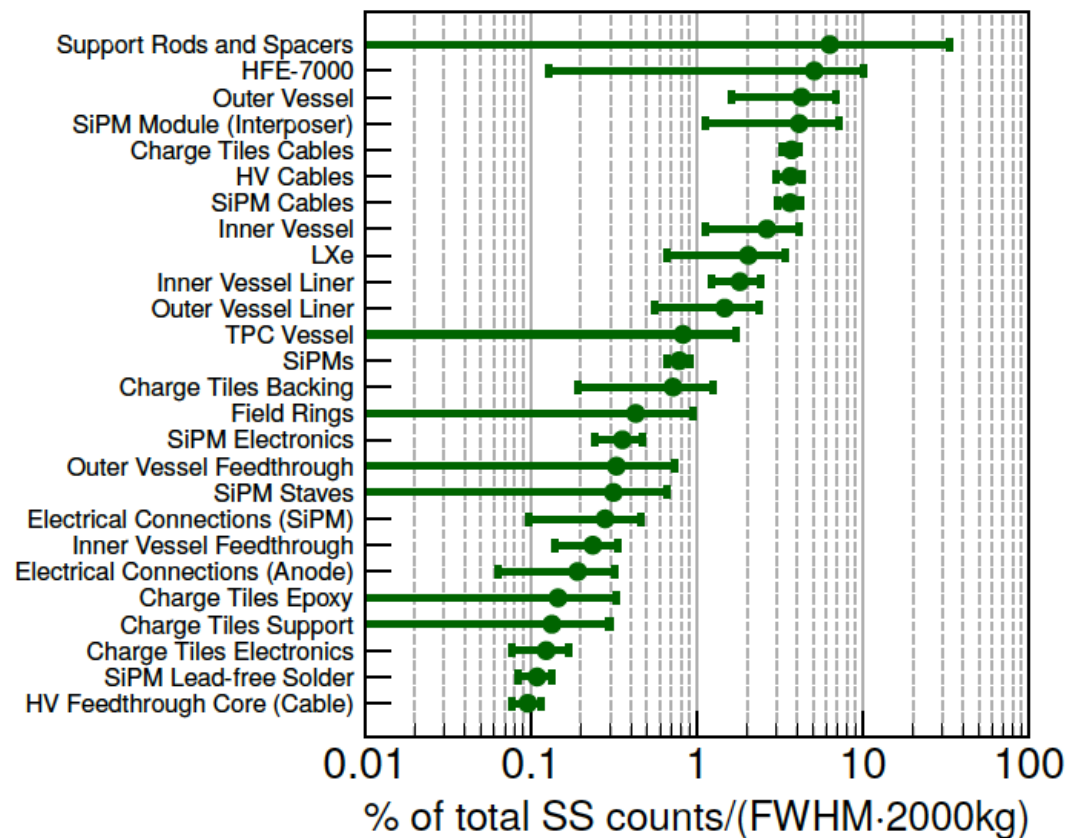

Figure 8. SS-like fractional background contributions with energy within $Q_{\beta\beta} \pm \text{FWHM}/2$ and in the inner 2000 kg. The contributions are grouped by category, as described in the text. For each category, the total contribution is shown by the solid marker, while individual contributions are indicated by open circles. Negligible contributions are not shown. For ^{222}Rn backgrounds, the breakdown by ^{214}Bi decay location (based on Table 6) is shown. Breakdown by the individual source terms is given for the other two background categories.

Phase-space factor
J. Kotila and F. Iachello, Phys Rev C 85, 034316 (2012)

Axial coupling
 $g_A = 1.27$

$$\frac{1}{T_{1/2}^0} = \frac{\langle m_{\beta\beta} \rangle^2}{m_e^2} G^{0\nu} g_A^4 |\mathcal{M}^{0\nu}|^2$$

Nuclear Matrix Element

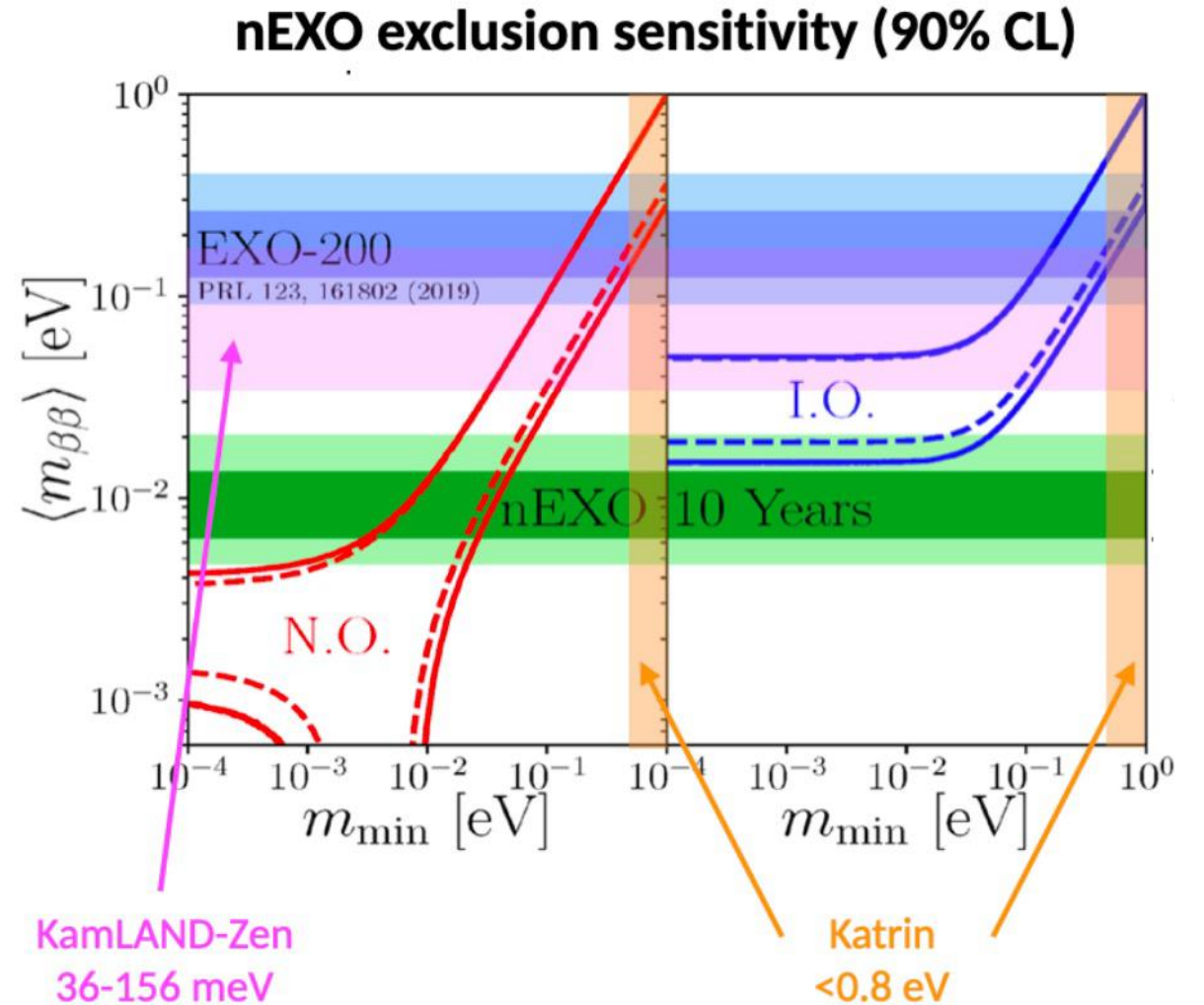

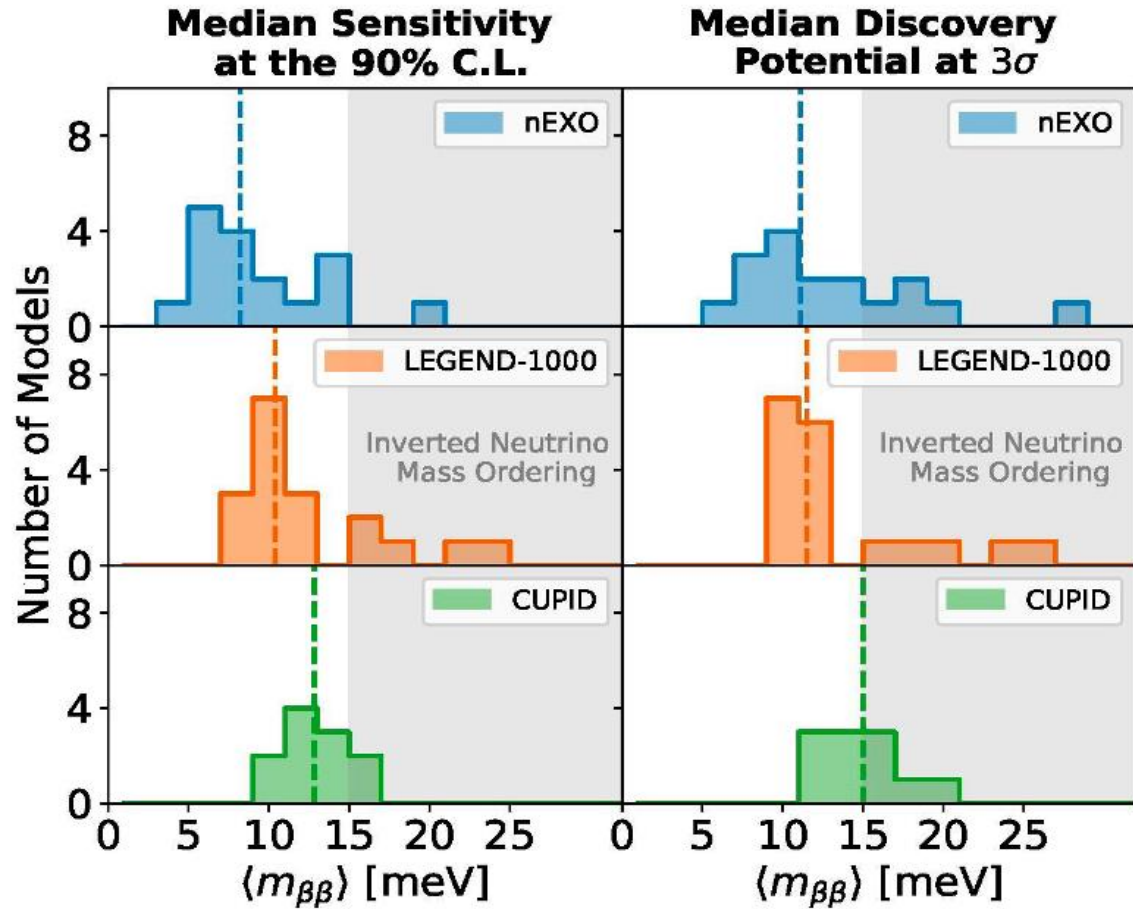

- $>10^{28}$ year sensitivity reach in 10 years
- Can provide compelling evidence of $0\nu\beta\beta$ decay discovery
- Probes $m_{\beta\beta} \sim 15$ meV (model and NME dependent)

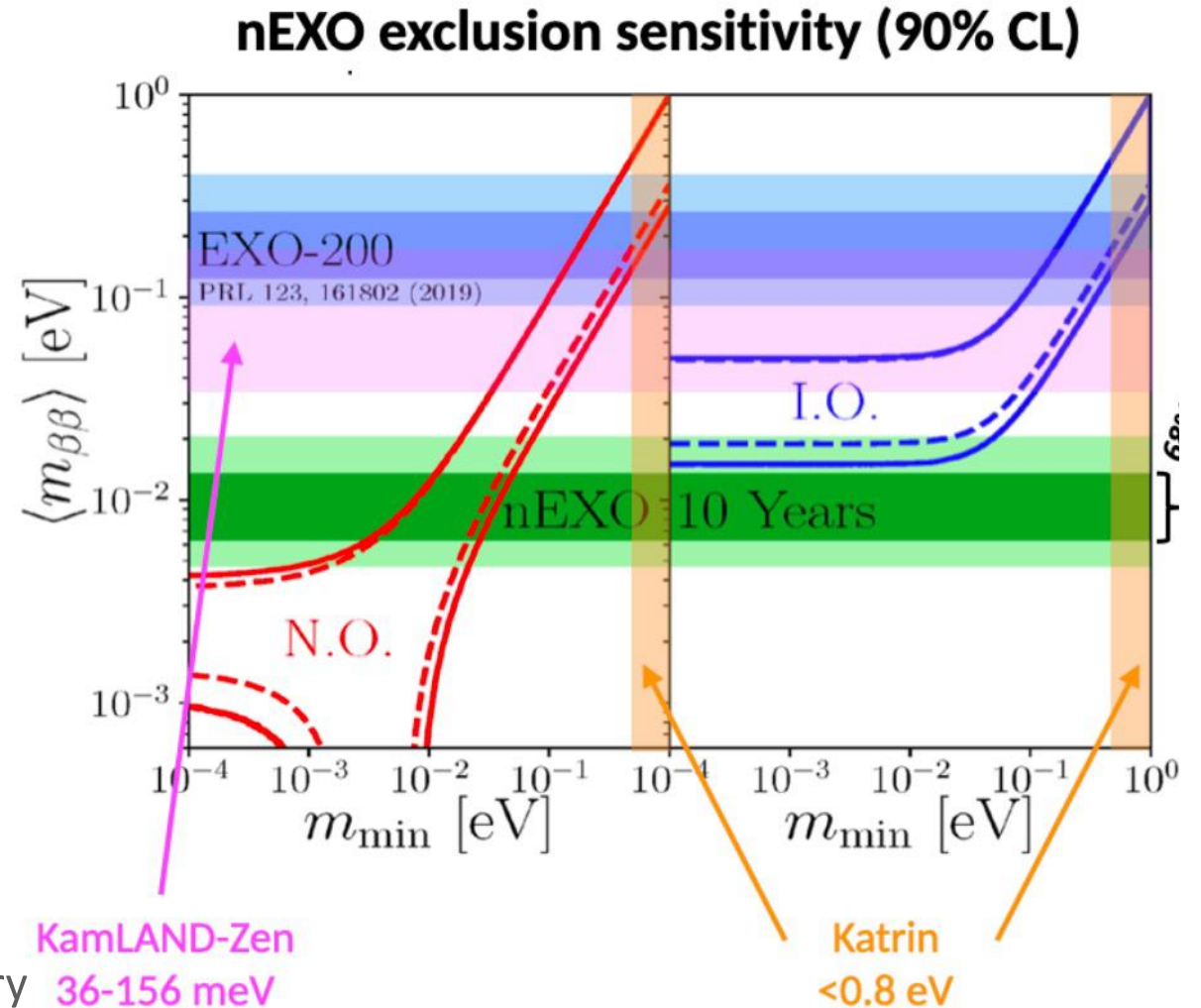

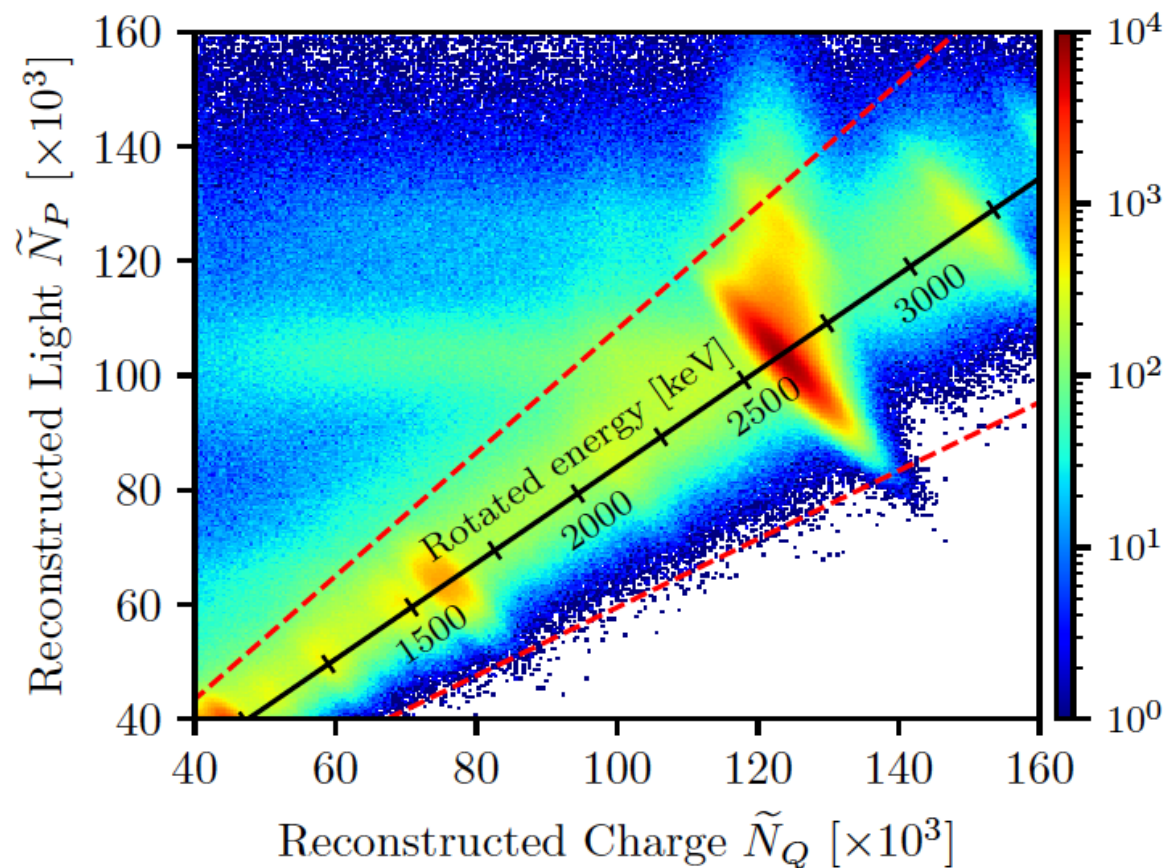

Figure 5. Reconstructed light and charge signals of all events in the FV from simulated ^{232}Th decays in the TPC vessel. The dashed lines indicate the location of the diagonal cut, described in the text. The rotated axis indicates the scale of the rotated energy.

HFE 2.5 MeV γ Attenuation

- “3M™ Novec™ 7200 Engineered Fluid is a liquid composed of Ethoxy-nonafluorobutane ($C_4F_9OC_2H_5$), 99% minimum.”
- Dense liquid at room & cryo. Temperatures \rightarrow Efficient γ -ray shield
- Highly radiopure material

Typical Physical Properties

Table 1

Properties	3M™ Novec™ 7200 Engineered Fluid	3M™ Novec™ 7100 Engineered Fluid	HFC-4310mee	HCFC-225 ca/cb
Formulation	$C_4F_9OC_2H_5$	$C_4F_9OCH_3$	$C_5H_2F_{10}$	$C_3Cl_2HF_5$
Molecular Wt.	264	250	252	203
Boiling Point ($^{\circ}C$)	76	61	54	54
Freeze Point ($^{\circ}C$)	-138	-135	-80	-131
Liquid Density (g/ml)	1.43	1.52	1.58	1.55
Surface Tension (dynes/cm)	13.6	13.6	14.1	16.2
Solubility of Solvent in Water (ppmw)	<20	12	140	330
Solubility of Water in Solvent (ppmw)	92	95	490	310
Vapor Pressure (mmHg)	109	202	226	290
Viscosity (cps)	0.61	0.61	0.67	0.59
Heat of Vaporization (cal/g @ boiling point)	30	30	31	34.6
Specific Heat (cal/g $^{\circ}C$)	0.29	0.28	0.27	0.24

All values at 25 $^{\circ}C$ unless otherwise specified

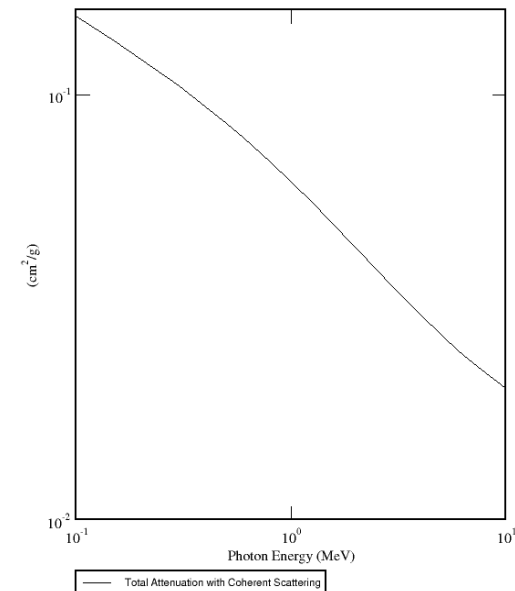
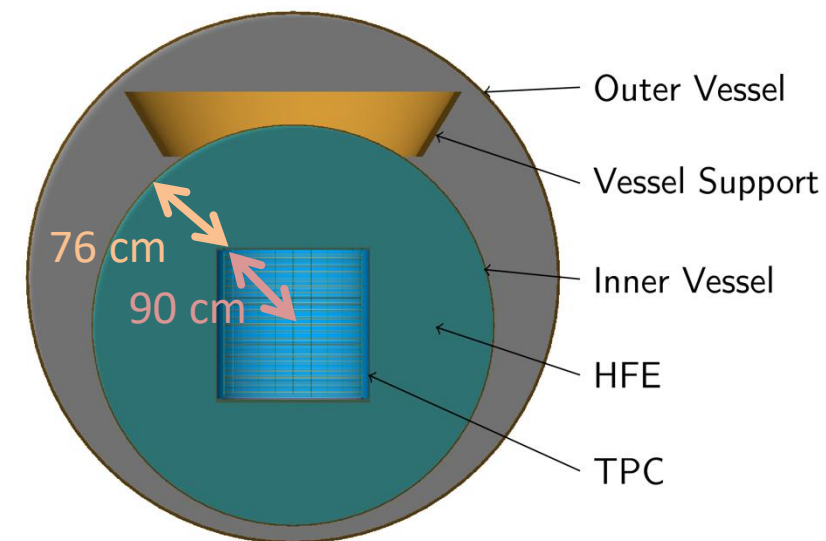

Simulation Geant4

- Code version: commit 9e001b0 (G4 10.7.2)
- Generated ^{214}Bi and ^{208}Tl as primaries in vessels liners (to be conservative)
- Launched 8 Slurm jobs: 1026, 1226, 1510, 1690 mm IV
- HFE volume is parameterized, no TPC Support
- $1\text{e}10$ primaries

Reconstruction Strax

- Code version: commit b325f0e
- Using new DNN (June 2024)
- Defined BackgroundAlg plugin:
 - $(2481 < \text{evt}["\text{energy}"] > 2435) \& (\text{evt}["\text{standoff}"] > 100) \& (\text{dnn_value} > 0.85)$
- Did reconstruction and background selection in Slurm jobs

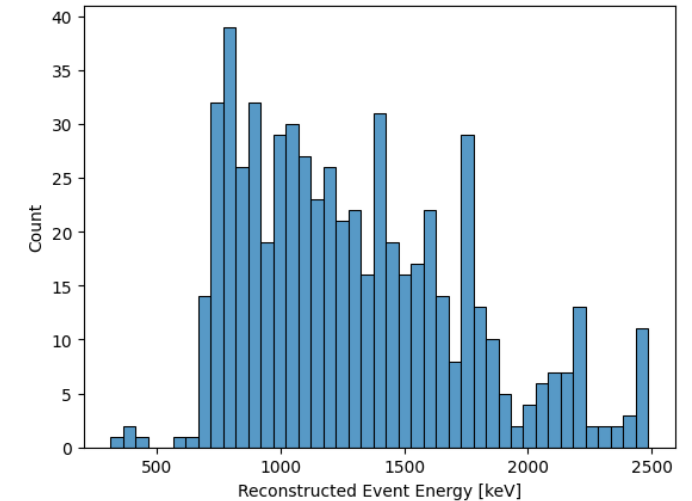
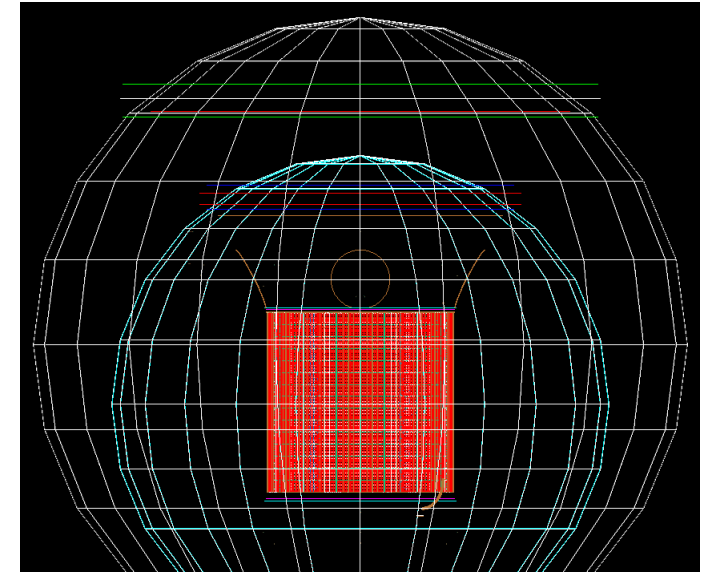

Less HFE = External Background

Increased

- OV, ^{222}Rn from water, ...
- Can be quantified with the attenuation law
- Geant4 simulations will be done

