

Initial data for binary black holes

Philippe Grandclément

October 7th, 2024

Laboratoire de l'Univers et Théories (LUTh)

CNRS / Observatoire de Paris

F-92195 Meudon, France

philippe.grandclement@obspm.fr

3+1 formalism

Foliation of spacetime

The 3+1 formalism is the most widely used way to write Einstein equations for NR. It makes explicit the split between space and time (see for instance Gourgoulhon (2012)).

Spacetime is foliated by a family of spatial hypersurfaces

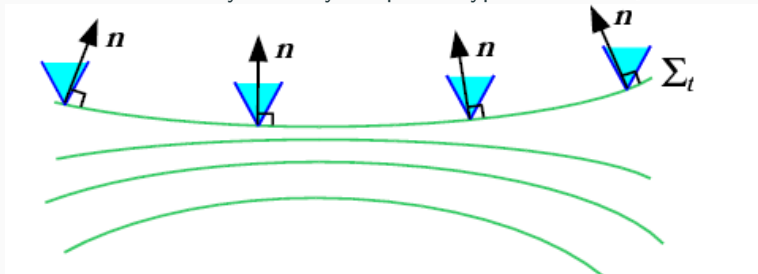

- Coordinate system of Σ_t : (x_1, x_2, x_3) .
- Coordinate system of spacetime : (t, x_1, x_2, x_3) .

Greek indices 4D (0, 1, 2, 3) and Latin 3D (1, 2, 3).

Unit normal

The unit normal can be written as $n^\mu = \left(\frac{1}{N}, -\frac{B^i}{N} \right)$.

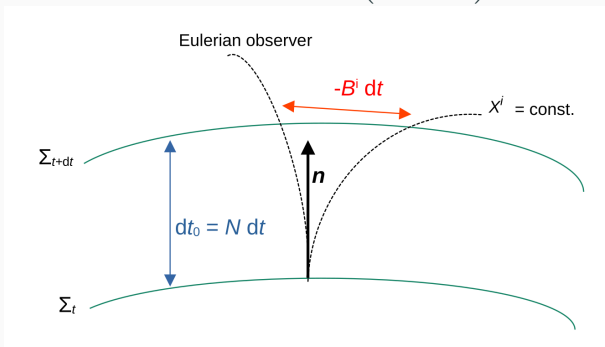

- N , the lapse, defines the choice of time coordinate (other notation α).
- B^i , the shift, defines the choice of spatial coordinates (other notations β^i , N^i).

Projections

- Projection on the normal of a vector \vec{V} is given by $n_\mu V^\mu$.
- Projection operator on the hypersurfaces $\gamma_\mu^\nu = g_\mu^\nu + n_\mu n^\nu$.
- Projection on the slices of a vector \vec{V} is given by $\gamma_\mu^\nu V^\mu$.
- Projection the 4D metric $g_{\mu\nu}$ is

$$\gamma_\alpha^\nu \gamma_\beta^\mu g_{\mu\nu} = \gamma_{\alpha\beta} = g_{\alpha\beta} + n_\alpha n_\beta$$

- The induced metric γ_{ij} is the first fundamental form.

The 4D line-element reads

$$ds^2 = - (N^2 - B^i B_i) dt^2 + 2B_i dt dx^i + \gamma_{ij} dx^i dx^j$$

Extrinsic curvature K_{ij}

- Describes the part of the geometry not accounted for by the induced metric.
- It describes the variation of normal projected on the hypersurface.

$$K_{ij} = -\gamma_i^\mu \gamma_j^\nu \nabla_\mu n_\nu$$

- In the 3+1 framework, it is given by

$$(\partial_t - \mathcal{L}_{\vec{B}}) \gamma_{ij} = -2NK_{ij}$$

- It is known as the second fundamental form.

Projection of Einstein's equations

The 3+1 equations are obtained by projecting $G_{\mu\nu} = 8\pi T_{\mu\nu}$ on n^α and on the hypersurfaces.

- projections onto $n^\mu n^\nu$, the Hamiltonian constraint:

$$R + K^2 - K_{ij}K^{ij} = 16\pi E.$$

- projection onto $n^\mu \gamma_i^\nu$, the momentum constraint:

$$D_j K_i^j - D_i K = 8\pi P_i.$$

- projection onto $\gamma_i^\nu \gamma_j^\mu$, the evolution equation:

$$\begin{aligned} \left(\frac{\partial}{\partial t} - \mathcal{L}_{\vec{B}}\right) K_{ij} = \\ -D_i D_j N + N \left(R_{ij} + K K_{ij} - 2K_{ik} K_j^k + 4\pi [(S - E) \gamma_{ij} - 2S_{ij}] \right). \end{aligned}$$

- E , P_i and S_{ij} are the various projections of $T_{\mu\nu}$.

Constraint equations

- The constraints are 4 equations, that do not contain ∂_t .
- Such equations are absent in Newtonian dynamics but not for Maxwell.

Type	Einstein	Maxwell
Constraints	Hamiltonian $R + K^2 - K_{ij}K^{ij} = 0$	$\nabla \cdot \vec{E} = 0$
	Momentum : $D_j K^{ij} - D^i K = 0$	$\nabla \cdot \vec{B} = 0$
Evolution	$\frac{\partial \gamma_{ij}}{\partial t} - \mathcal{L}_{\vec{B}} \gamma_{ij} = -2NK_{ij}$ $\frac{\partial K_{ij}}{\partial t} - \mathcal{L}_{\vec{B}} K_{ij} = -D_i D_j N + N (R_{ij} - 2K_{ik}K_j^k + KK_{ij})$	$\frac{\partial \vec{E}}{\partial t} = \frac{1}{\epsilon_0 \mu_0} (\vec{\nabla} \times \vec{B})$ $\frac{\partial \vec{B}}{\partial t} = -\vec{\nabla} \times \vec{E}$

A two steps problem

Evolution problem

- Given initial value of $\gamma_{ij}(t=0)$ and $K_{ij}(t=0)$ use the evolution equations to determine the fields at later times.
- Similar to writing Newton's equation as $\partial_t x = v; \partial_t v = f/m$.
- Must ensure stability and accuracy.
- Must choose the lapse and shift in a clever way.

Initial data

- $\gamma_{ij}(t=0)$ and $K_{ij}(t=0)$ are not arbitrary but subject to the constraint equations.
- It is a set of four elliptic coupled equations.
- Needs to make the link between a given physical situation and the mathematical objects γ_{ij} and K_{ij}

Static solutions

Simplest assumptions

Hypothesis

- Conformal flatness : $\gamma_{ij} = \Psi^4 f_{ij}$, where f_{ij} is the flat metric.
- Initially static : $K_{ij} = 0$ (equivalent to no initial velocity).

Equations

- The momentum constraint is trivially verified.
- The Hamiltonian constraint reduces to $\Delta\Psi = 0$.

Brill-Lindquist data (Brill and Lindquist (1963))

- The presence of two holes is enforced by imposing the divergence of Ψ at two points :

$$\Psi = 1 + \frac{\alpha_1}{\|\vec{r} - \vec{c}_1\|} + \frac{\alpha_2}{\|\vec{r} - \vec{c}_2\|}.$$

- A first asymptotic flat region is $r \rightarrow \infty$.
- It defines the mass of the binary : $m = 2(\alpha_1 + \alpha_2)$.

Behavior close to the singularities

- Define $\vec{r}_1 = \vec{r} - \vec{c}_1$ and make $r_1 \rightarrow 0$
- New radius coordinate : $\bar{r}_1 = \frac{\alpha_1^2}{r_1}$
- One can show that region $\bar{r}_1 \rightarrow \infty$ is also asymptotically flat.
- It defines the mass of an individual black hole $m_1 = 2\alpha_1 \left(1 + \frac{\alpha_2}{c_{12}} \right)$
with $c_{12} = ||\vec{c}_1 - \vec{c}_2||$.

A topology with three sheets

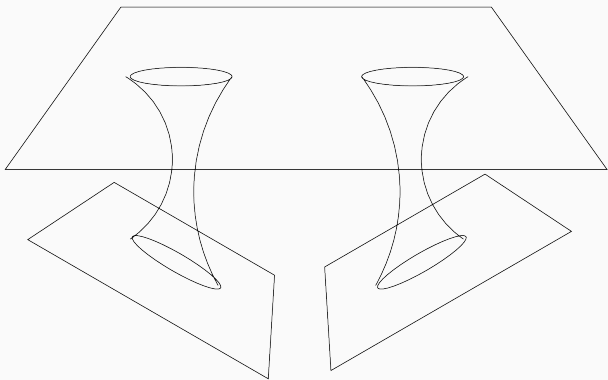

Misner-Lindquist data (Misner (1963); Lindquist (1963))

- Objective : ensures that the two lower-sheets coincide.
- Define two throats at \vec{c}_i with radii a_i .
- The inversion wrt to a throat is defined as

$$M(r_i, \theta_i, \varphi_i) \rightarrow J_i(M) \left(\frac{a_i^2}{r_i}, \theta_i, \varphi_i \right).$$

- Construct a solution that gives the same result when J_1 or J_2 is applied.
- Involves an operator constructed with combinations of J_i .

Explicit form of Misner-Lindquist data

$$\Psi = 1 + \sum_{n=1}^{\infty} c_n \left(\frac{1}{\|\vec{r} - \vec{d}_n\|} + \frac{1}{\|\vec{r} + \vec{d}_n\|} \right).$$

with $\vec{d}_n = d_n \vec{u}$, \vec{u} the unit vector between the throats.

- Explicit expressions for c_n and d_n are known.
- Only two asymptotic regions with the same mass : $m = 4 \sum_{n=1}^{\infty} c_n$.
- Individual masses can be obtained, assuming that the expressions obtained in the Brill-Lindquist case are valid.

A topology with two sheets

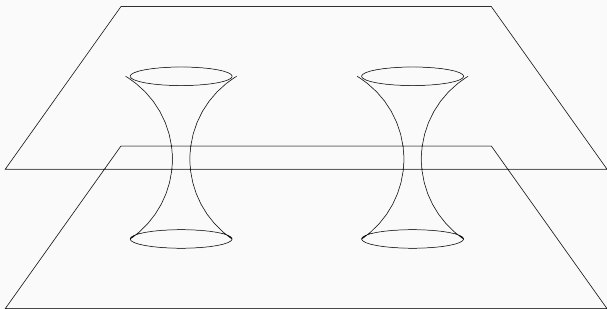

Two classes of black hole computations

Misner-Lindquist as an elliptic problem with boundaries

- Solve $\Delta \Psi = 0$, outside the throats (i.e. for $r_1 > a_1$ and $r_2 > a_2$).
- The inversion with respect to the throats enforces that

$$\left. \frac{\partial \Psi}{\partial r_i} + \frac{1}{2a_i} \Psi \right|_{r_i=a_i} = 0.$$

- Equivalent to demanding that the throats are horizons.

Two techniques

- Brill-Lindquist : the puncture method.
- Misner-Lindquist : the excision method.

Non-static solutions

Single black hole case

- One considers solutions with $K_{ij} \neq 0$.
- Analytic solutions of $D_j K^{ij} - D^i K = 0$ are known.
- $\hat{K}_{ij} = \Psi^2 K_{ij}$.
- Some are associated with a linear momentum : $\hat{K}_{ij}(\vec{P})$.
- Some are associated with an angular momentum : $\hat{K}_{ij}(\vec{S})$.
- As the momentum constraint is linear in K_{ij} , one can combine such solutions.

Puncture method (Brandt and Bruegmann (1997); Baumgarte (2000))

- Extension of Brill-Lindquist data.
- Set the extrinsic curvature tensor to

$$\hat{K}_{ij} = \hat{K}_{1ij}(\vec{P}) + \hat{K}_{2ij}(-\vec{P}) + \hat{K}_{1ij}(\vec{S}_1) + \hat{K}_{2ij}(\vec{S}_2).$$

- Assume that the conformal factor diverges at two points :

$$\Psi = b^{-1} + u \quad \text{with} \quad b^{-1} = \frac{\alpha_1}{\|\vec{r} - \vec{c}_1\|} + \frac{\alpha_2}{\|\vec{r} - \vec{c}_2\|}.$$

- Solve the Hamiltonian constraint for the regular part u (Poisson-like equation):

$$\Delta u + \frac{b^7}{8} \hat{K}_{ij} \hat{K}^{ij} \frac{1}{(1+bu)^7} = 0$$

Excision method (Kulkarni et al. (1983))

- Extension of Misner-Lindquist data.
- Start with the extrinsic curvature tensor

$$\hat{K}_{ij}^{\text{init}} = \hat{K}_{1ij}(\vec{P}) + \hat{K}_{2ij}(-\vec{P}) + \hat{K}_{1ij}(\vec{S}_1) + \hat{K}_{2ij}(\vec{S}_2).$$

- Construct from that a solution that is isometric with respect to the inversion wrt the throats.
- It makes use of combinations of J_1 and J_2 .
- Analytic expressions for \hat{K}_{ij} can be found.
- The conformal factor is obtained from the Hamiltonian constraint equation:

$$\Delta\Psi = -\frac{1}{8}\Psi^{-7}\hat{K}_{ij}\hat{K}^{ij}.$$

- That equation is solved outside the throats with

$$\left. \frac{\partial\Psi}{\partial r_i} + \frac{1}{2a_i}\Psi \right|_{r_i=a_i} = 0.$$

Limitations of those methods

- ID did not perform well in evolution codes (maybe other problems...)
- Global quantities are very different from post-Newtonian results.
- Probably comes from the explicit choice made the extrinsic curvature tensor.

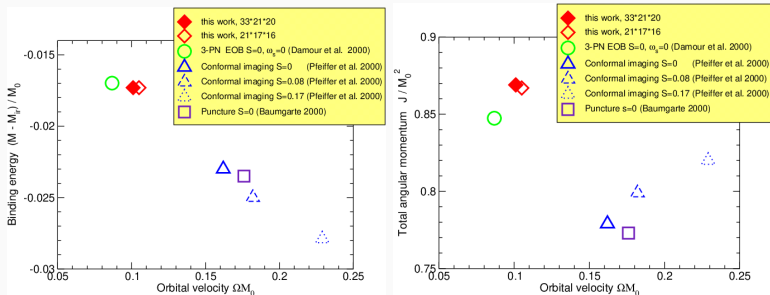

from Grandclement et al. (2002)

The extended thin-sandwich method

Conformal traceless decomposition

- Define the conformal factor as $\Psi = \left(\frac{\det \gamma_{ij}}{\det f_{ij}} \right)^{1/12}$.
- $\gamma_{ij} = \Psi^4 \tilde{\gamma}_{ij}$ so that $\det \tilde{\gamma}_{ij} = \det f_{ij}$.
- $K_{ij} = \Psi^4 \tilde{A}_{ij} + \frac{1}{3} K \gamma_{ij}$ with $\tilde{\gamma}^{ij} \tilde{A}_{ij} = 0$.
- Different powers of Ψ may be used, especially in defining \tilde{A}_{ij} .

Extrinsic curvature

Given the definition of the extrinsic curvature tensor, one gets

$$\tilde{A}^{ij} = \frac{1}{2N} \left((LB)^{ij} + \tilde{u}^{ij} \right).$$

- The indices are manipulated using $\tilde{\gamma}$.
- $\tilde{u}^{ij} = \partial_t \tilde{\gamma}^{ij}$.
- $(LB)^{ij} = \tilde{D}^i B^j + \tilde{D}^j B^i - \frac{2}{3} \tilde{D}_k B^k \tilde{\gamma}^{ij}$.

Original thin-sandwich method

Freely specifiable variables

K , $\tilde{\gamma}_{ij}$, \tilde{u}^{ij} and N .

The unknowns

- The shift B^i .
- The conformal factor Ψ .

The equations

- The Hamiltonian constraint.
- The momentum constraints.

Difficulty in choosing the lapse in a meaningful manner.

Extended thin-sandwich method (Gourgoulhon et al. (2002); Caudill et al. (2006))

Add an equation

- Consider the trace of the evolution equation.
- It becomes an equation on $\partial_t K$ because $\gamma^{ij} \partial_t K_{ij} = \partial_t K + K_{ij} \tilde{u}^{ij}$.

New set of freely specifiable variables

K , $\tilde{\gamma}_{ij}$, \tilde{u}^{ij} and $\partial_t K$.

- The unknowns are N , B^i and Ψ .
- The equations are the constraints and the trace of the evolution equation.

Quasi-equilibrium configurations

One assumes that the binary is almost on a circular orbit : existence of an helical Killing vector.

Inertial coordinates

- Killing vector : $k^\alpha = (1, 0, 0, \Omega)$
- $B_{\text{inert}}^i \rightarrow 0$

Corotating coordinates

- Killing vector : $k^\alpha = (1, 0, 0, 0)$
- $B_{\text{cor}}^i \rightarrow \Omega \partial_\varphi^i$

$$B_{\text{cor}}^i = B_{\text{inert}}^i + \Omega \partial_\varphi^i$$

Choice of the freely specifiable variables

- Maximal slicing : $K = 0$.
- Stationnarity : $\partial_t K = 0$ and $\tilde{u}_{ij} = \partial_t \tilde{\gamma}_{ij} = 0$.
- Conformal flatness : $\tilde{\gamma}_{ij} = f_{ij}$.
 - It is only true at 1PN order.
 - It is not true for Kerr for instance.
 - It simplifies the equations.
 - It kills the GW emission.
 - It is consistent with the helical symmetry.

Resulting bulk equations

- trace of the evolution equation :

$$D_i D^i N = -2 \frac{D_i \Psi D^i N}{\Psi} + N \Psi^4 \tilde{A}_{ij} \tilde{A}^{ij}.$$

- Hamiltonian constraint

$$D_i D^i \Psi = -\frac{\Psi^5}{8} \tilde{A}_{ij} \tilde{A}^{ij}.$$

- Momentum constraints

$$D_j D^j B^i + \frac{1}{3} D^i D_j B^j = 2 \tilde{A}^{ij} \left(D_j N - 6N \frac{D_j \Psi}{\Psi} \right).$$

with $\tilde{A}^{ij} = \frac{1}{2N} \left(D^i B^j + D^j B^i - \frac{2}{3} D_k B^k f_{ij} \right).$

The indices are manipulated with f_{ij} and the covariant derivatives are also taken with respect to f_{ij} .

Inner boundary conditions

Apparent horizons

- Excision method : solve the equation outside of two spheres.
- Impose that they are apparent horizons in equilibrium.
- Let s_a^i be the unit spatial normal to the hole a .

Resulting BCs

- $N = \frac{1}{2}$: coordinate choice, other possibilities are available.
- $\frac{\partial \Psi}{\partial r} + \frac{\Psi}{2r} + \frac{\Psi^3}{4} \tilde{A}_{ij} s_a^i s_a^j = 0$: apparent horizon condition.
- $B^i = \frac{N}{\Psi^2} s_a^i - \Omega \partial_\varphi^i$: horizon in equilibrium and global rotation (corotating case).

Asymptotic flatness

- $N = 1$
- $\Psi = 1$
- $B^i = 0$: work with the inertial shift.

Orbital angular velocity

- Ω appears as a parameter in the equations (BC on the shift).
- Must be fixed by the separation and sizes of the holes.
- The general relativistic theorem states that the Komar M_K and ADM M_{ADM} masses must coincide.
- Both quantities are given as surface integrals at infinity.
- The condition $M_K = M_{ADM}$ fixes Ω .
- It is equivalent to minimizing some kind of binding energy of the binary.

Some examples of fields

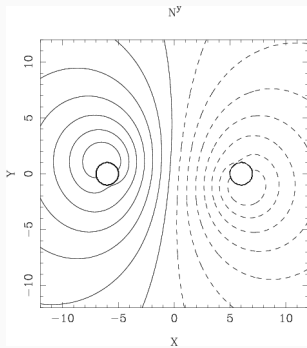
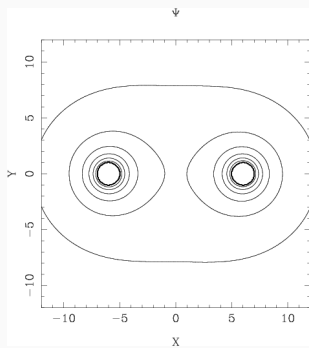
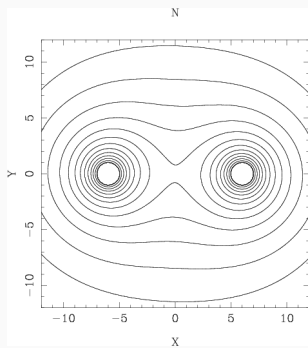

from Grandclement (2010)

Advanced topics (1/2)

Unequal mass binaries

- The local masses of the holes can be measured by surface integrals on the horizons.
- It can be used to choose the mass ratio.
- The location of the rotation axis of the binary is unknown.
- It is fixed by demanding that the linear momentum P_{ADM}^i vanishes.

Spinning black holes

- Additional contribution on the shift inner BC.
- $B^i = \frac{N}{\Psi^2} s_a^i - \Omega \partial_\varphi^i + \Omega_a \partial_{\varphi_a}^i$.
- φ_a^i is associated to the hole a .
- Surface integrals can be used to measure the individual spins and to fix Ω_a for each hole.
- Non-aligned spins are possible in principle but more difficult numerically.

Eccentricity reduction

- Initial data usually exhibit spurious eccentricity in evolution codes.
- It can be cured by slightly modifying the boundary condition on the shift :

$$B^i = \frac{N}{\Psi^2} s_a^i - (\Omega + \delta\Omega) \partial_\varphi^i + \dot{a} r_a^i$$

- The quantities $\delta\Omega$ and \dot{a} can be obtained from PN calculations or iteratively from numerical evolutions of the data.

Some results

Numerical precision

Initial data obtained by the library Kadath with spectral methods (Grandclement (2010)).

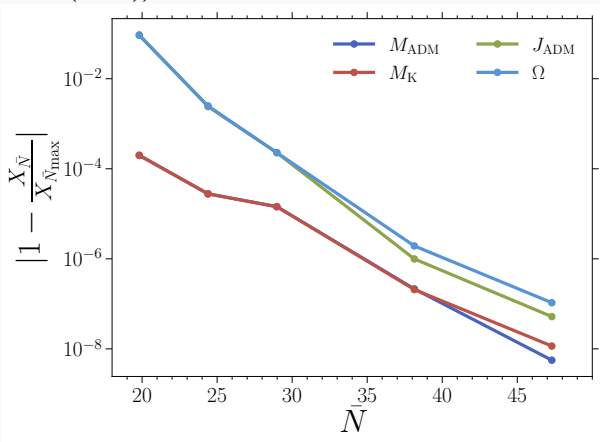

from Papenfort et al. (2021)

Binding energy

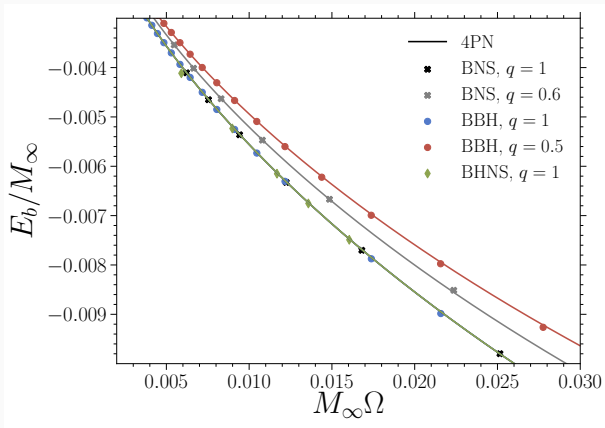

from Papenfort et al. (2021)

Good agreement with PN results.

Evolution of the ID for BBH (GW150914)

Evolution with the puncture method : need to “fill” the holes of the initial data.

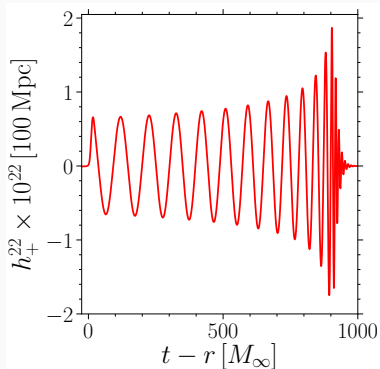
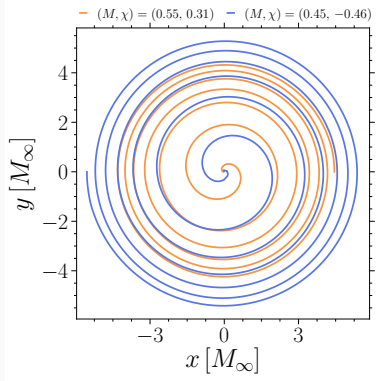

from Papenfort et al. (2021)

Conclusions

- The initial value problem for binaries has a very long history.
- Since the 2000s, the problem is relatively under control.
- Big improvement in using the extended thin sandwich approach.
- It enables a better choice for the freely specifiable variables.
- Additional advanced techniques : spins, eccentricity reduction.
- Also works with matter for BNS systems.
- Possible extensions : remove the conformal flatness approximation, exotic objects.

References

- Baumgarte, T. W. (2000). The Innermost stable circular orbit of binary black holes. *Phys. Rev. D*, 62:024018.
- Brandt, S. and Bruegmann, B. (1997). A Simple construction of initial data for multiple black holes. *Phys. Rev. Lett.*, 78:3606–3609.
- Brill, D. R. and Lindquist, R. W. (1963). Interaction energy in geometrostatics. *Phys. Rev.*, 131:471–476.
- Caudill, M., Cook, G. B., Grigsby, J. D., and Pfeiffer, H. P. (2006). Circular orbits and spin in black-hole initial data. *Phys. Rev. D*, 74:064011.
- Gourgoulhon, E. (2012). *3+1 Formalism in General Relativity*, volume 846 of *Lecture Notes in Physics*. Springer Berlin, Heidelberg.
- Gourgoulhon, E., Grandclement, P., and Bonazzola, S. (2002). Binary black holes in circular orbits. 1. A Global space-time approach. *Phys. Rev. D*, 65:044020.
- Grandclement, P. (2010). Kadath: A Spectral solver for theoretical physics. *J. Comput. Phys.*, 229:3334–3357.
- Grandclement, P., Gourgoulhon, E., and Bonazzola, S. (2002). Binary black holes in circular orbits. 2. Numerical methods and first results. *Phys. Rev. D*, 65:044021.
- Kulkarni, A., Shepley, L., and York, Jr., J. W. (1983). Initial data for N black holes. *Phys. Lett. A*, 96:228–230.

- Lindquist, R. W. (1963). Initial-Value Problem on Einstein-Rosen Manifolds. *Journal of Mathematical Physics*, 4(7):938–950.
- Misner, C. W. (1963). The method of images in geometrostatics. *Annals of Physics*, 24:102–117.
- Papenfort, L. J., Tootle, S. D., Grandclément, P., Most, E. R., and Rezzolla, L. (2021). New public code for initial data of unequal-mass, spinning compact-object binaries. *Phys. Rev. D*, 104(2):024057.