

The Path Towards the Future Circular Collider at CERN

Emmanuel Tsesmelis (CERN)
Head of Associate Member State and Non-Member State Relations
Convenor of FCC Global Collaboration Working Group

Talk-for-Guides: FCC Communication towards Visitors
11 March 2024



Swiss Accelerator
Research and
Technology

<http://cern.ch/fcc>



Work supported by the **European Commission** under the **HORIZON 2020** projects **EuroCirCol**, grant agreement 654305; **EASITrain**, grant agreement no. 764879; **iFAST**, grant agreement 101004730, **FCCIS**, grant agreement 951754; **E-JADE**, contract no. 645479; **EAJADE**, contract number 101086276; and by the Swiss **CHART** program



European
Commission

Horizon 2020
European Union funding
for Research & Innovation

photo: J. Wenninger

CERN is the world's biggest laboratory for particle physics.

Our goal is to understand the most fundamental particles and laws of the universe.

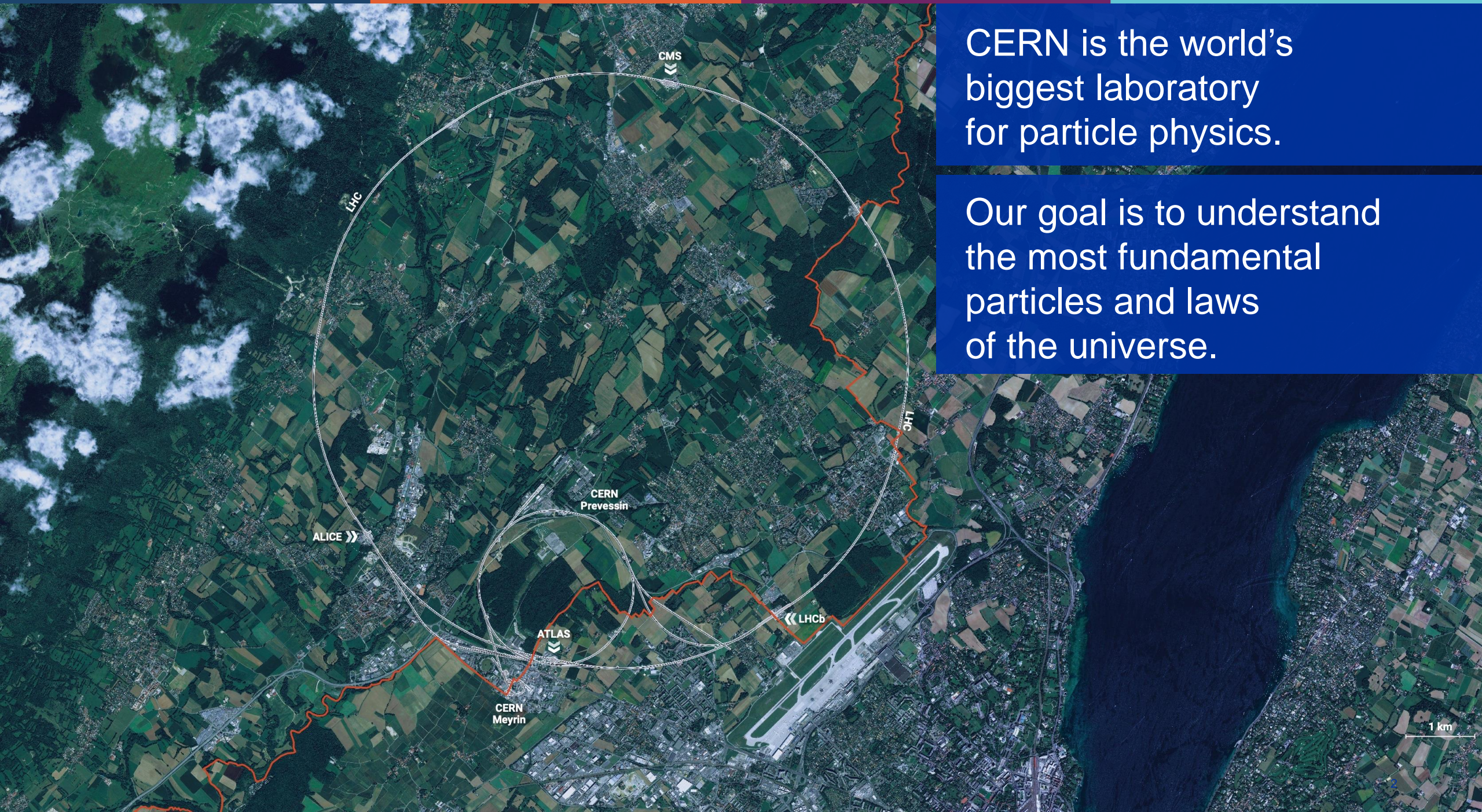

Four pillars underpin CERN's mission



What is the universe made of?

We study the elementary building blocks of matter and the forces that control their behaviour

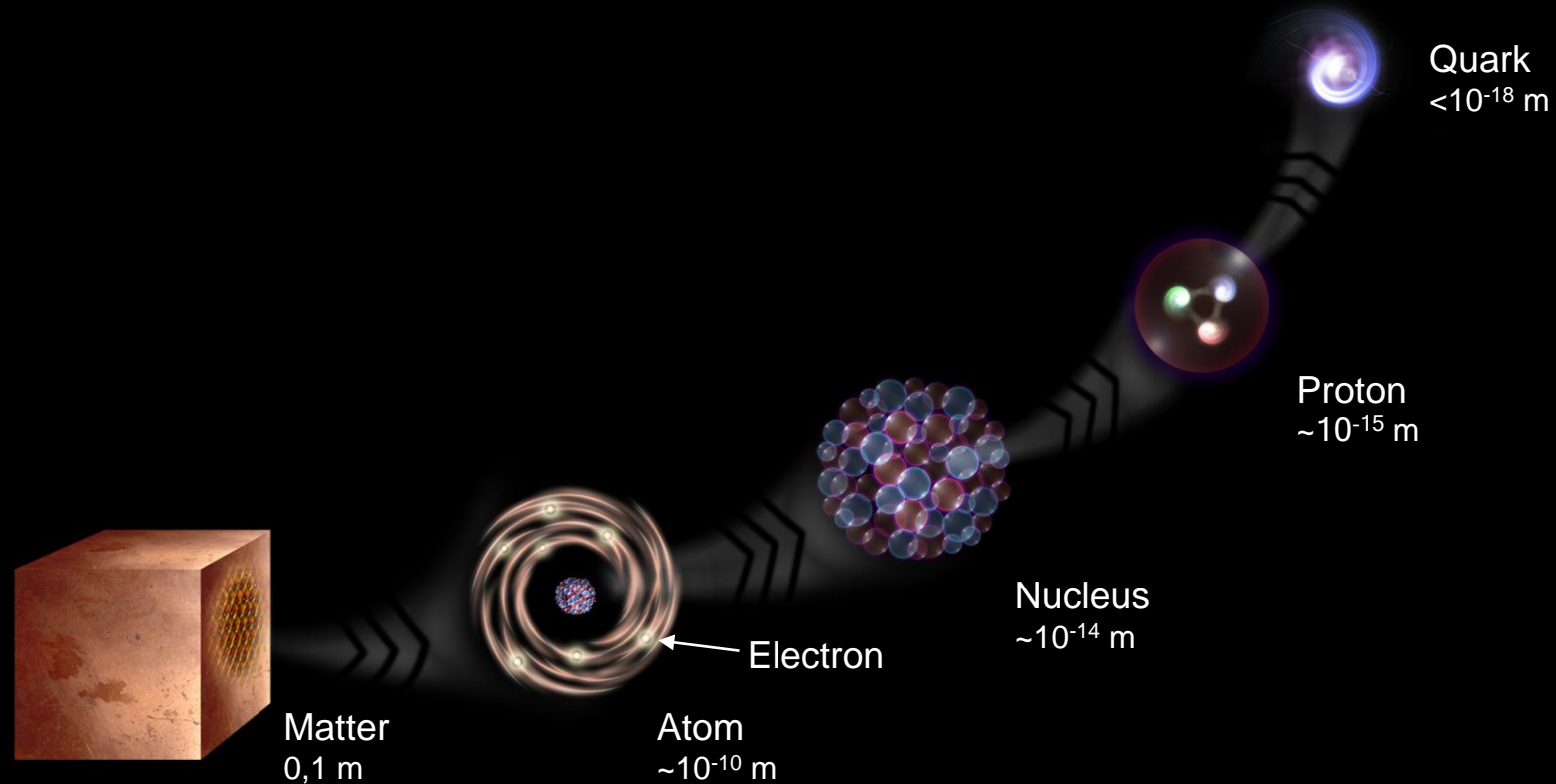

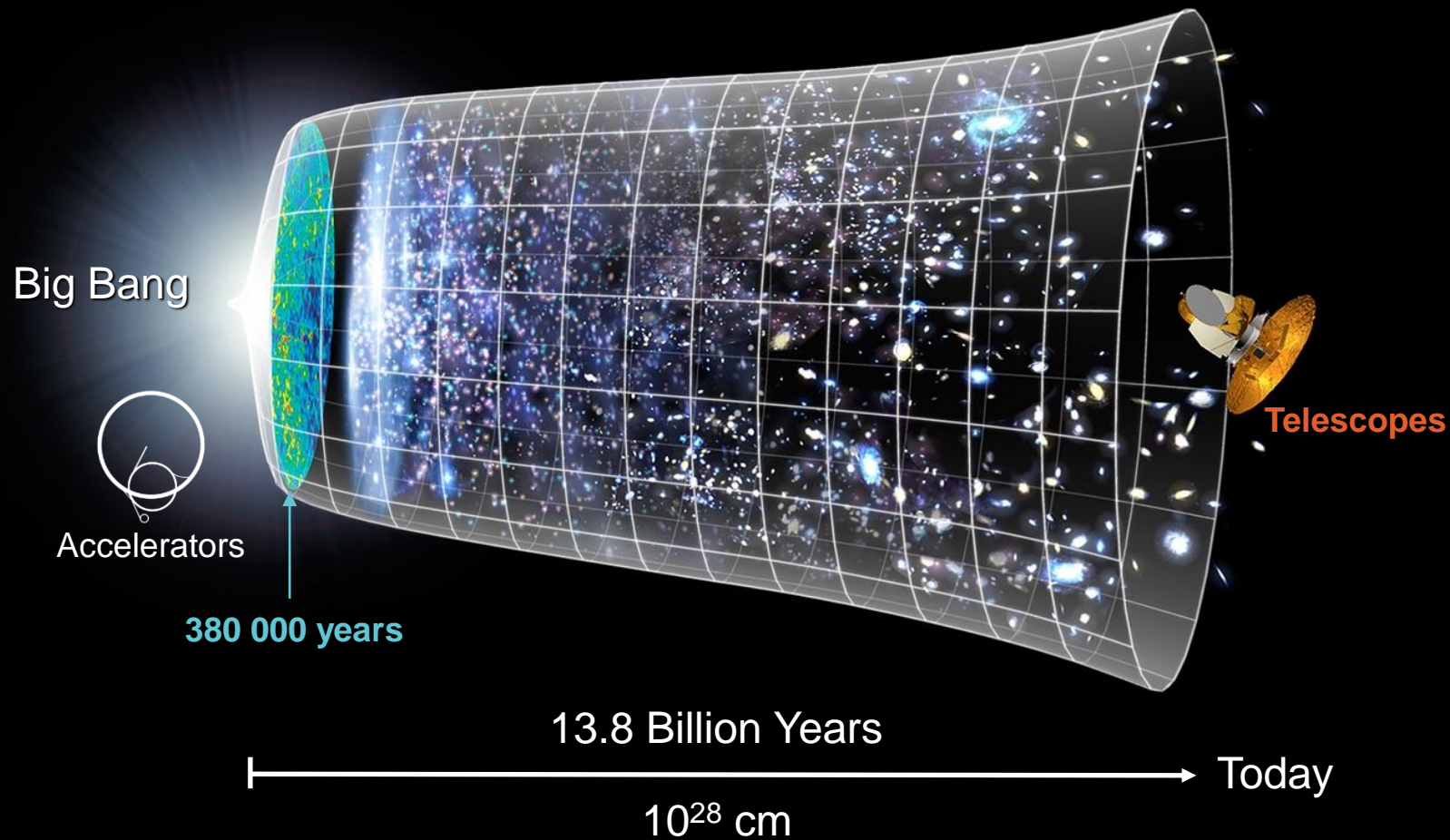

How did the universe begin?

We reproduce the conditions a fraction of a second after the Big Bang, to gain insight into the structure and evolution of the universe.

Synergies with fields of astronomy, astrophysics and cosmology

At CERN we help to answer these questions



Carlo Rubbia



Simon Van der Meer

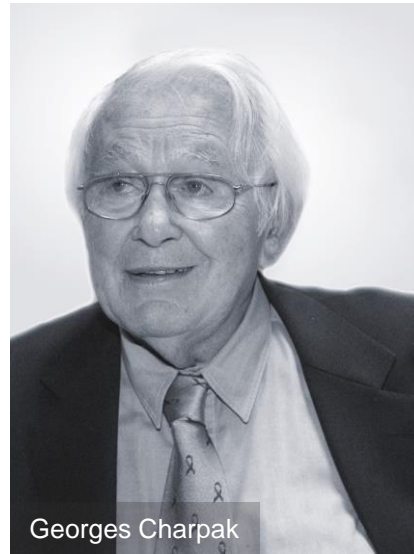

Georges Charpak

Several CERN scientists have received Nobel Prizes for key discoveries in particle physics.

The Higgs boson was discovered in 2012; without it fundamental particles would be massless and atoms could not form.



François Englert and Peter Higgs. With Robert Brout, they proposed the mechanism in 1964.

Accelerator Development

Characterised by rapid progress for over a century.

- From cathode-ray tubes to the LHC.
- From the discovery of the electron to the discovery of the Higgs boson.

Advances in accelerators require corresponding advances in accelerator technologies

- Magnets, vacuum systems, RF systems, diagnostics,...

Timelines becoming long, requiring:

- Long-term planning.
- Long-term resources.
- Global collaboration.

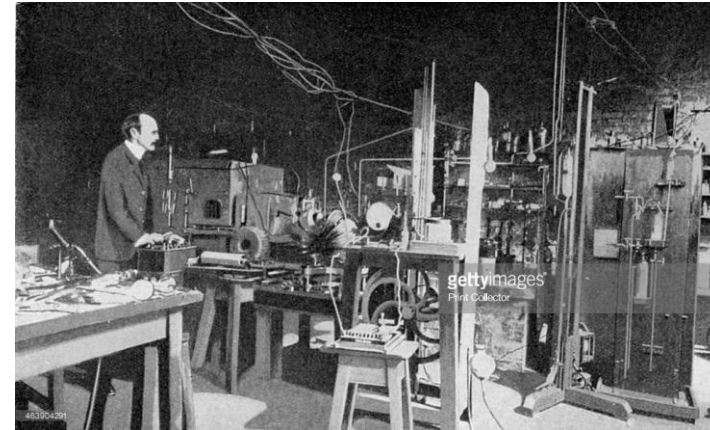

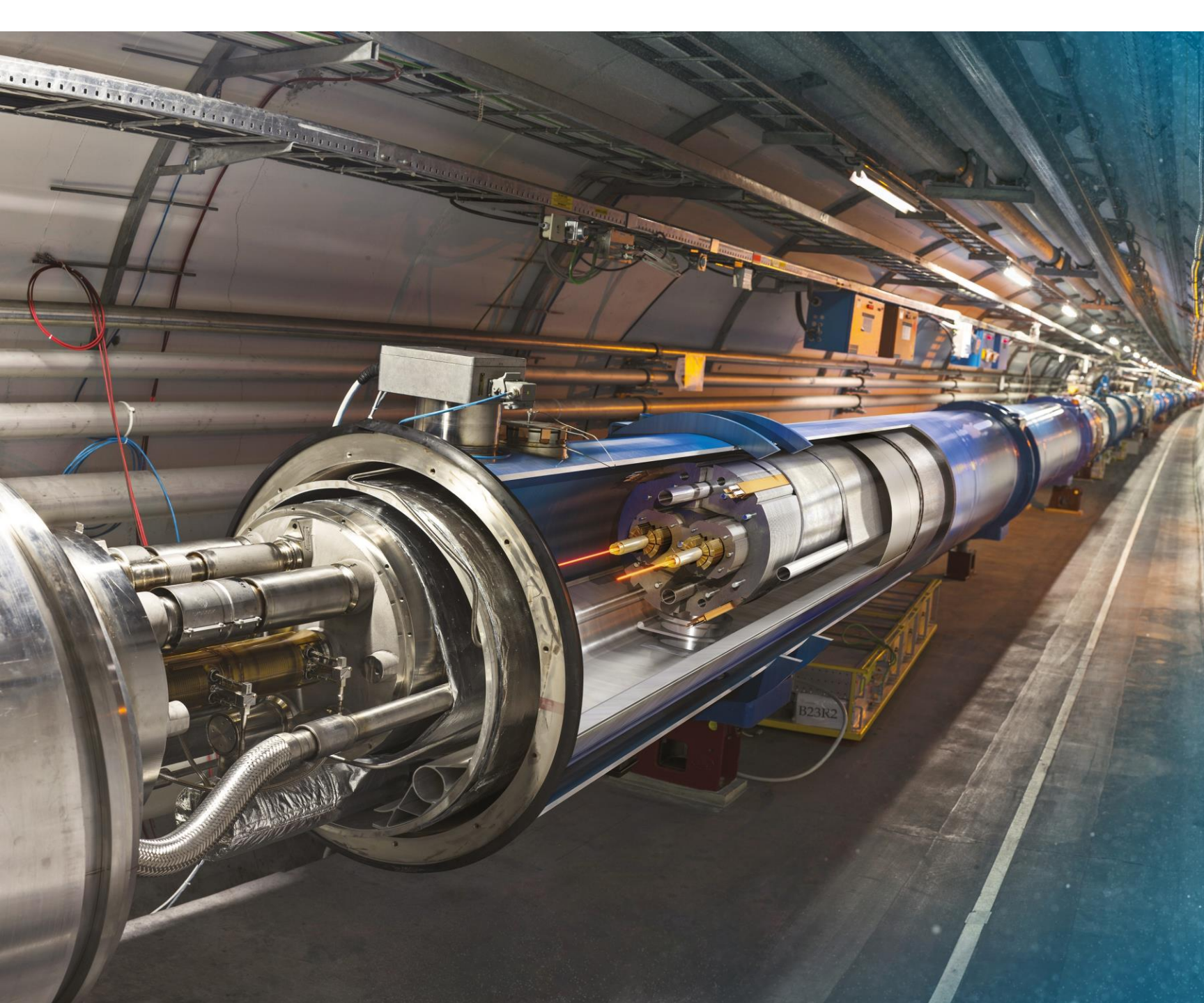

Large Hadron Collider (LHC)

- 27 km in circumference
- About 100 m underground
- Superconductivity is the enabling technology for magnets and RF cavities.

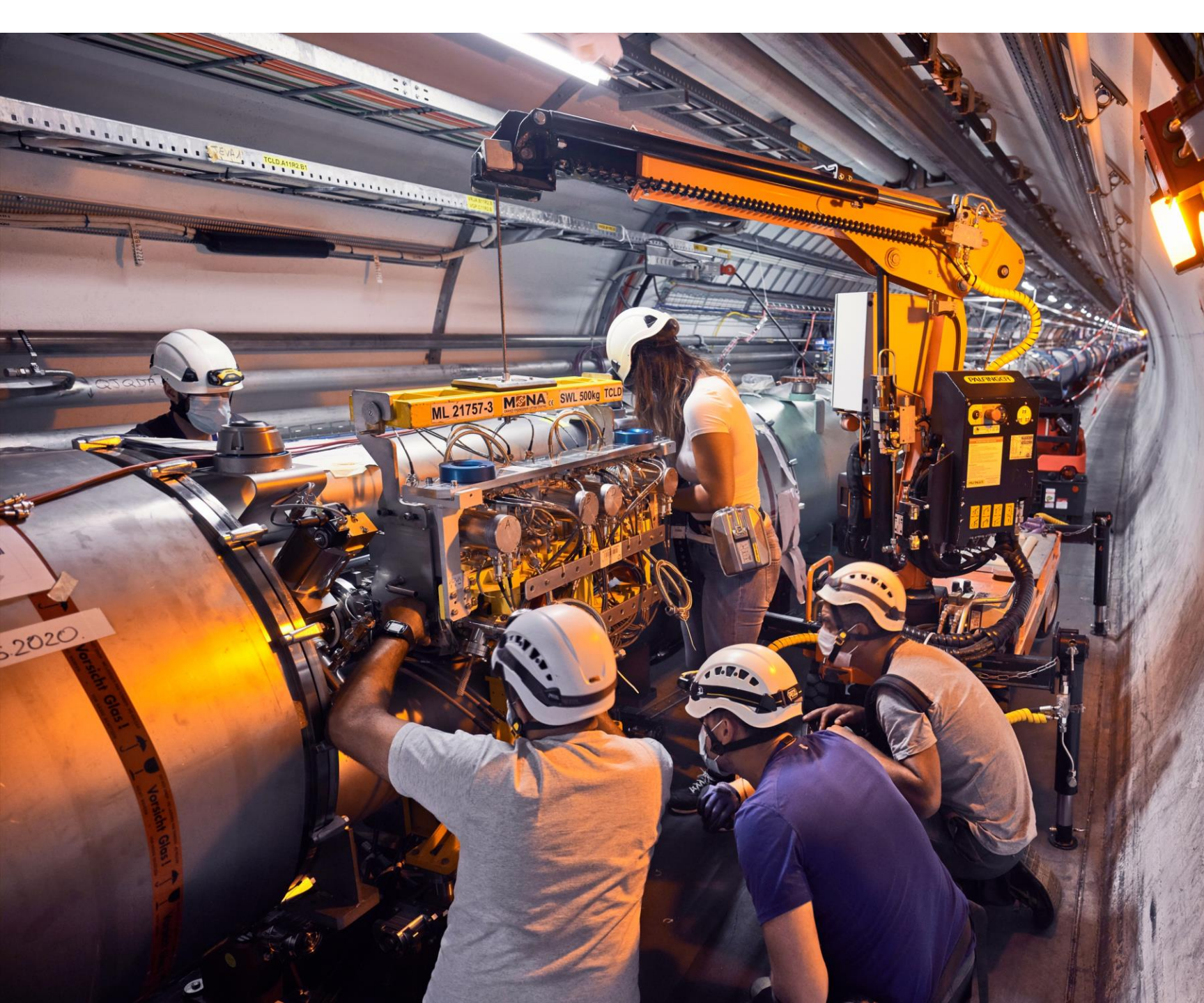

Upgrade to the High-Luminosity LHC is under way

- The HL-LHC will use new technologies to provide 10 times more collisions than the LHC.
- It will give access to rare phenomena, improved precision and discovery potential.
- It will start operating in 2029 and run until 2040.

The LHC / HL-LHC will make significant progress but new collider needed to advance research in totally new areas.

There are many unanswered questions in fundamental physics

Including

What is the unknown
95% of the mass
and energy
of the universe?

Is there only one Higgs
boson, and does it
behave exactly as
expected?

Why is the universe
made only of matter,
with hardly any
antimatter?

Why is gravity so weak
compared to the other
forces?

Preparing CERN's Future

Driven by the 2020 Update of the European Strategy for Particle Physics

- Technical and financial feasibility study of a Future Circular Collider (**FCC**).
- Accelerator R&D to develop technologies for FCC and for alternative options.
- Detector and computing R&D.
- Maintain and expand a compelling scientific diversity programme.
- Continue to support other projects around the world.

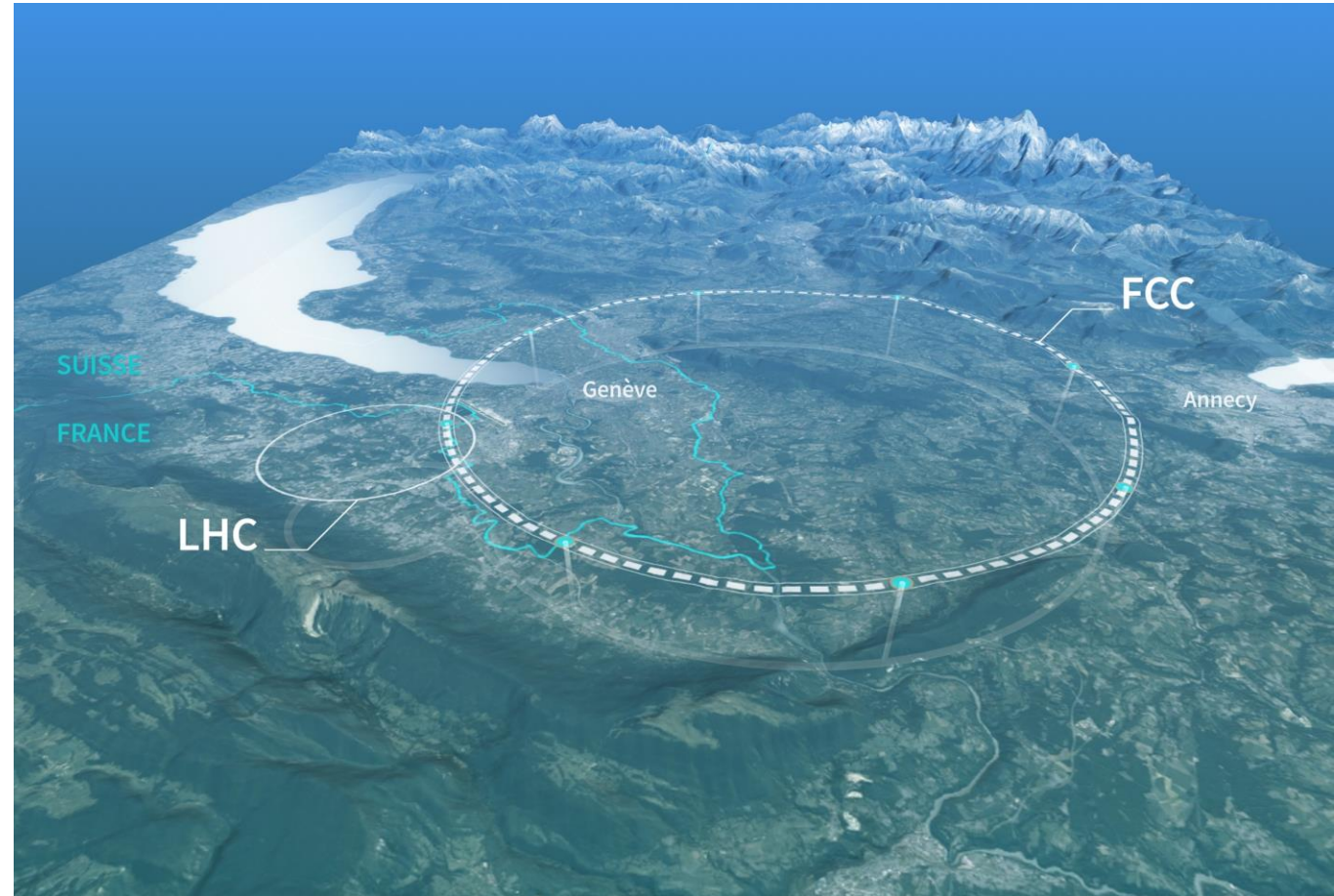

CERN Research Infrastructure

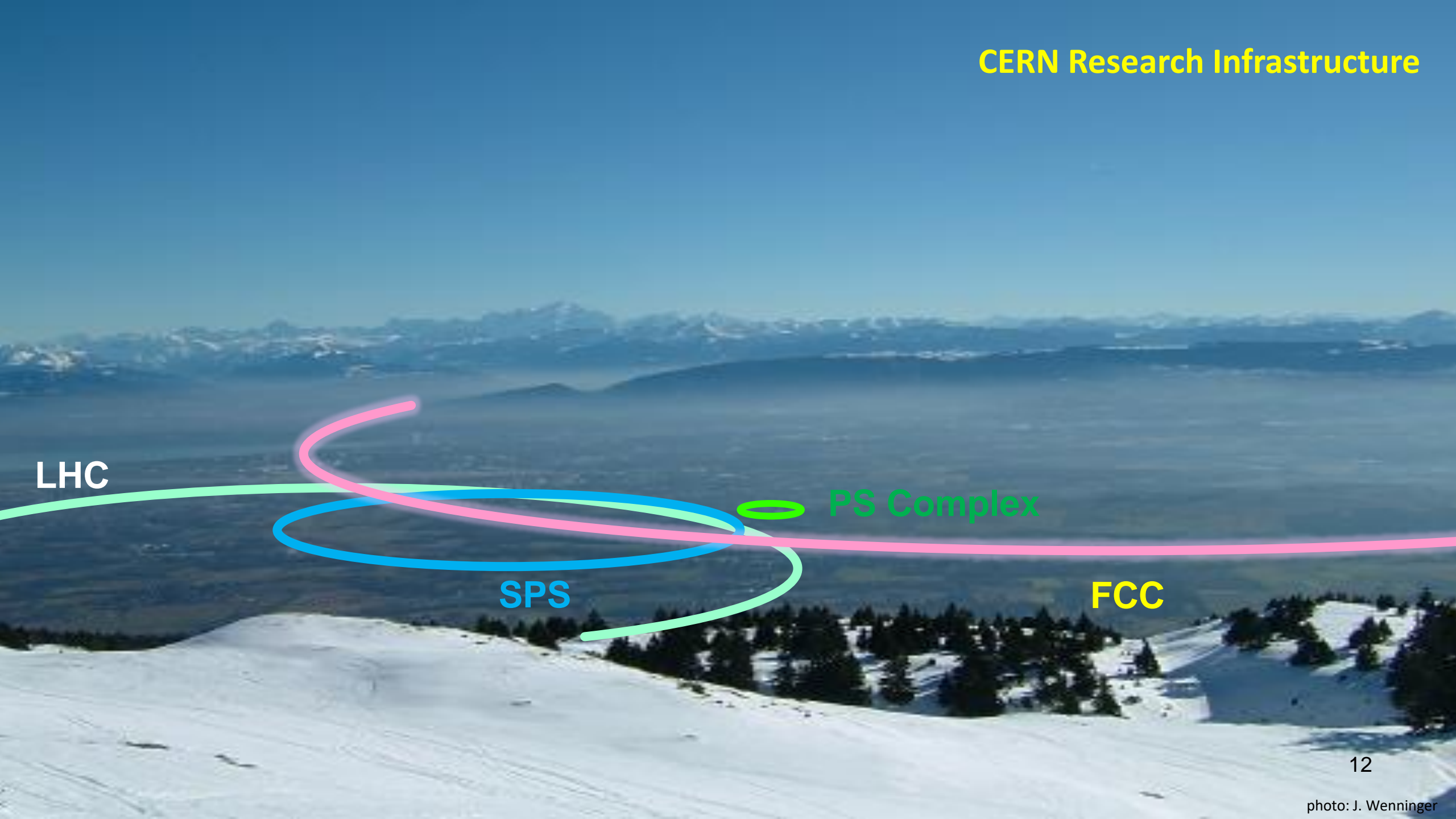

LHC

PS Complex

SPS

FCC

FCC Integrated Programme

Comprehensive long-term programme maximising physics opportunities

- Stage 1: FCC-ee (Z, W, H, $t\bar{t}$) as Higgs factory, electroweak & top factory at highest luminosities
- Stage 2: FCC-hh (~100 TeV) as natural continuation at energy frontier, pp & AA collisions; e-h option
- Highly synergetic and complementary programme boosting the physics reach of both colliders
- Common civil engineering and technical infrastructures, building on and reusing CERN's existing infrastructure
- FCC integrated project allows the start of a new, major facility at CERN within a few years of the end of HL-LHC

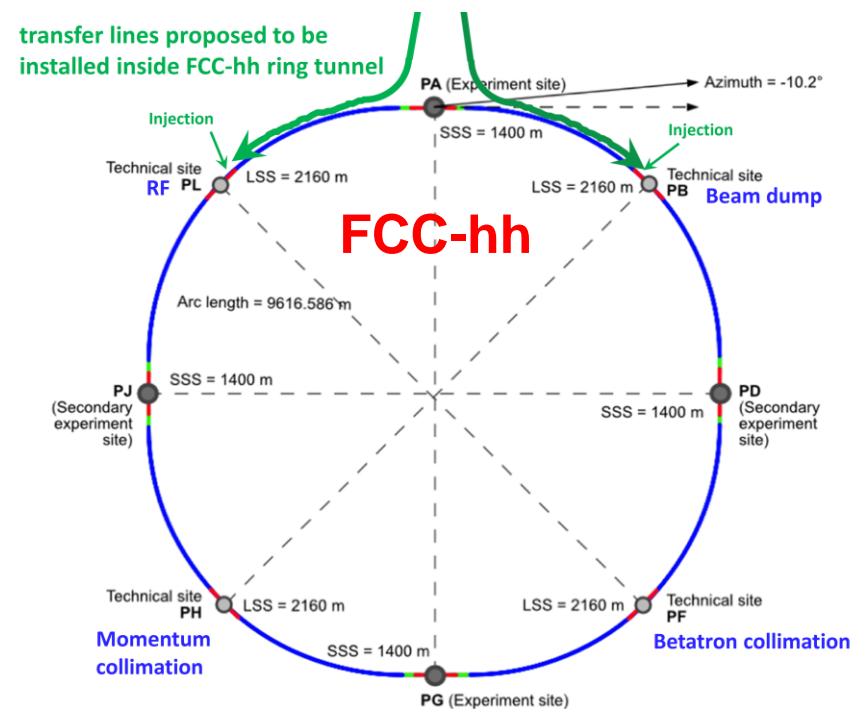
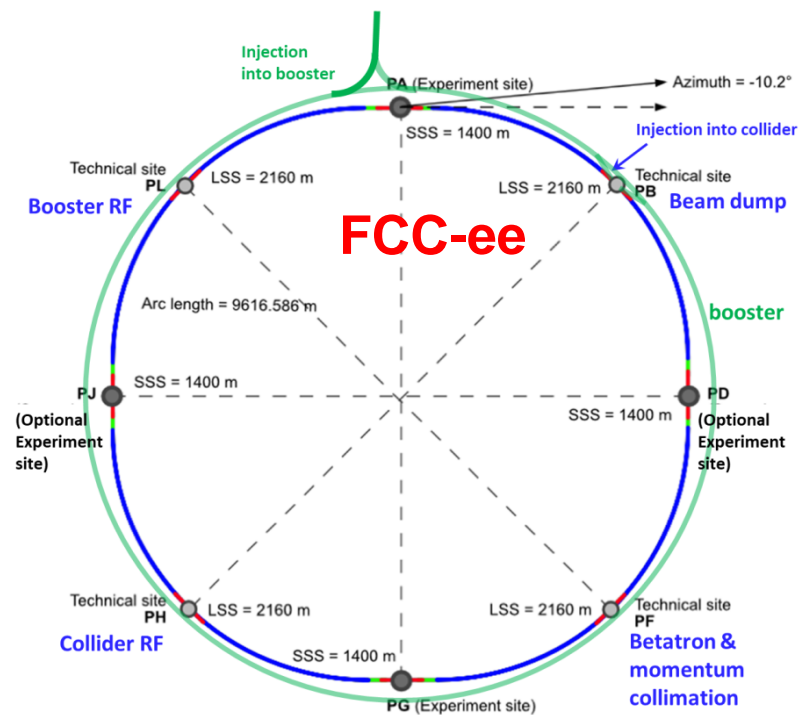
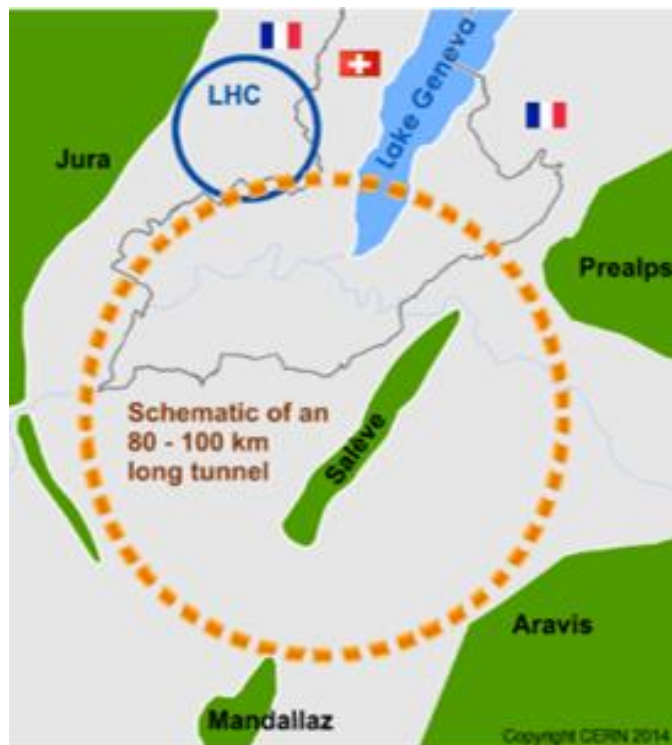

The LHC Legacy (so far)

- ▶ **Standard Model (SM) confirmed to high accuracy up to energies of several TeV** (thanks to a firm control of exp. & th. syst. uncertainties, the LHC became a precision machine)
- ▶ **Higgs boson discovered** at the mass predicted* by LEP precision EW measurements

*within the Standard Model

- ▶ **Absence of new physics**

TeV-scale Naturalness might not explain DM/baryogenesis
Traditional New Physics models are under siege

New approaches: relaxion, Nnaturalness, clockwork...

Cosmology might settle the vacuum of the SM

We need a **broad, versatile** and **ambitious** programme that

1. **Sharpens** our knowledge of already discovered physics

2. **Pushes** the frontiers of the unknown at high and low scales

Together FCC-ee & FCC-hh combine these two aspects

More **PRECISION** and more **ENERGY** for more **SENSITIVITY** to **New Physics**

FCC-ee Collider Programme

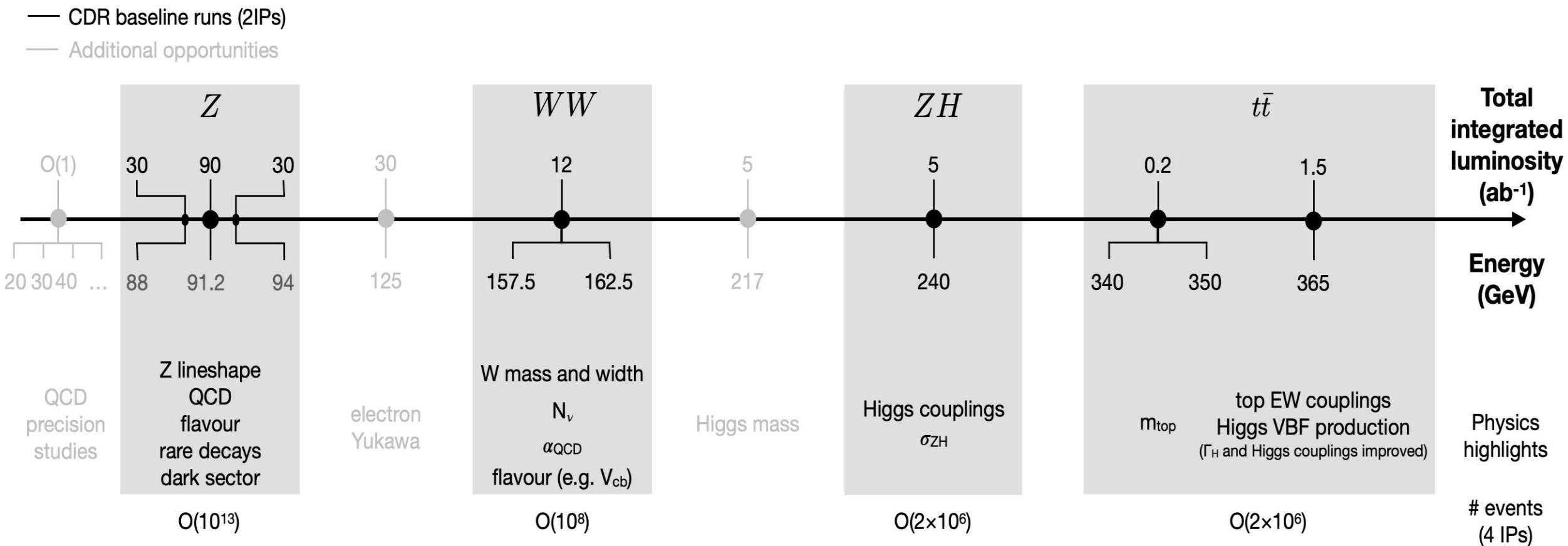

- **Opportunities** beyond the baseline plan (\sqrt{s} below Z, 125GeV, 217GeV; larger integrated lumi...)
- **Opportunities** to exploit FCC facility differently (to be studied more carefully):
 - using the electrons from the injectors for beam-dump experiments,
 - extracting electron beams from the booster,
 - reusing the synchrotron radiation photons.

FCC-ee Run Plan

LEP1 data accumulated in **every 2 mn.** Exciting & diverse programme with different priorities every few years.
(order of the different stages still subject to discussion/optimisation)

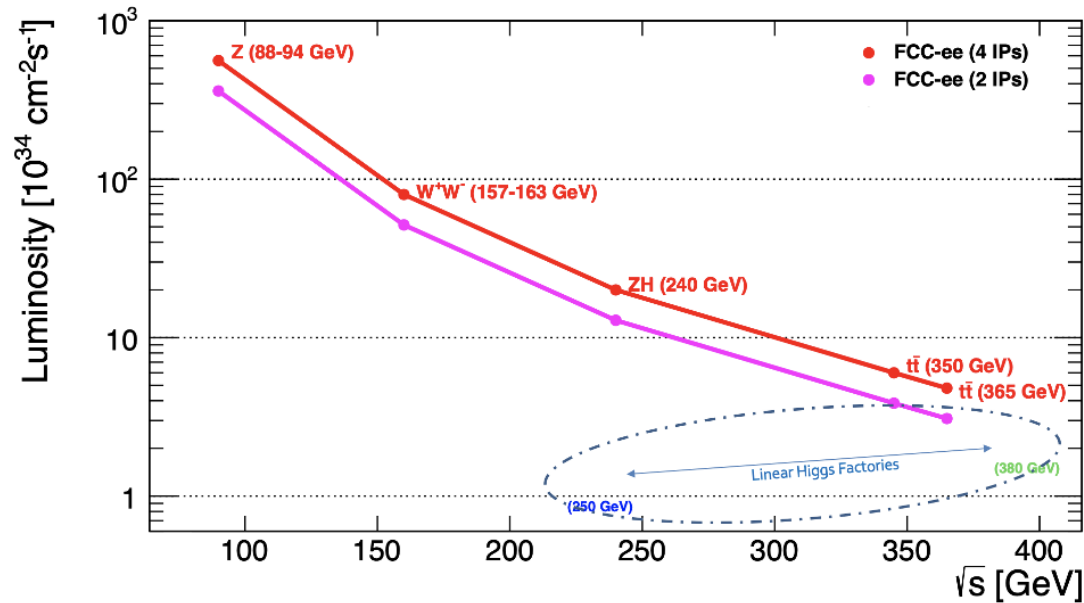

Statistics achieved in

in each detector:
 **10^5 Z/sec, 10^4 W/hour,
1500 Higgs/day, 1500 top/day**

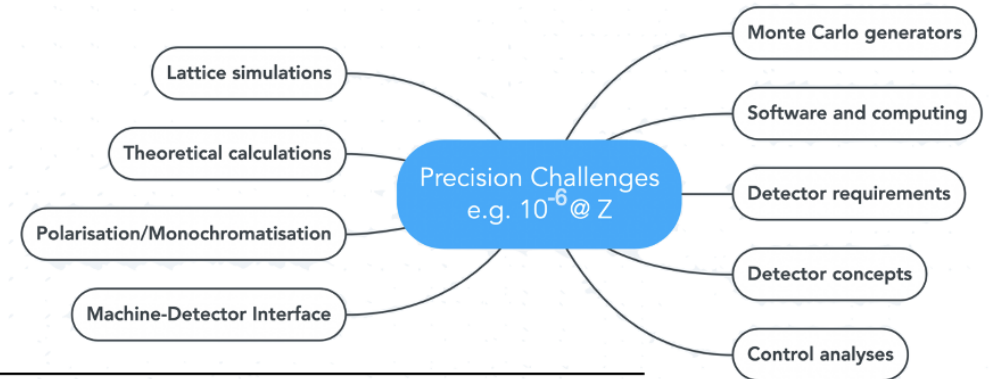

Working point	Z, years 1-2	Z, later	WW, years 1-2	WW, later	ZH	$t\bar{t}$
\sqrt{s} (GeV)	88, 91, 94		157, 163		240	340–350 365
Lumi/IP ($10^{34} \text{ cm}^{-2} \text{ s}^{-1}$)	70	140	10	20	5.0	0.75 1.20
Lumi/year (ab^{-1})	34	68	4.8	9.6	2.4	0.36 0.58
Run time (year)	2	2	2	–	3	1 4
Number of events	6×10^{12} Z		2.4×10^8 WW		1.45×10^6 ZH + 45k WW \rightarrow H	1.9×10^6 $t\bar{t}$ +330k ZH +80k WW \rightarrow H

EXPLORE INDIRECTLY the 10 -100 TeV energy scale with precision measurements

From the correlated properties of the Z , b, c, τ , W, Higgs, and top particles

Up to 20-50-fold improved precision on ALL electroweak observables (EWPO)

→ m_Z , m_W , m_{top} , Γ_Z , $\sin^2 \theta_W^{\text{eff}}$, R_b , $\alpha_{\text{QED}}(m_Z)$, $\alpha_s(m_Z, m_W, m_t)$, top EW couplings ...

Up to 10 × more precise and model-independent Higgs couplings (width, mass) measurements

→ Access the Higgs potential and infer the vacuum structure of the Universe

→ Reveals the dynamics of the EW phase transition and infer the fate of the EW vacuum

DISCOVER that the Standard Model does not fit

New Physics! → Pattern of deviations may point to the source.

DISCOVER a violation of flavour conservation / universality

$Z \rightarrow \tau \mu$ in 5×10^{12} Z decays; $\tau \rightarrow \mu \nu / e \nu$ in 2×10^{11} τ decays; $B^0 \rightarrow K^{*0} \tau^+ \tau^-$ or $B_s \rightarrow \tau^+ \tau^-$ in 10^{12} bb evts

DISCOVER dark matter, e.g., as invisible decays of Higgs or Z

DISCOVER DIRECTLY elusive (aka feebly-coupled) particles

in the 5-100 GeV mass range, such as right-handed neutrinos, dark photons, light Higgs-like scalars, dilaton, ALPs, relaxions...

Number of Resonances Produced

FCC-

hh Mass Reach

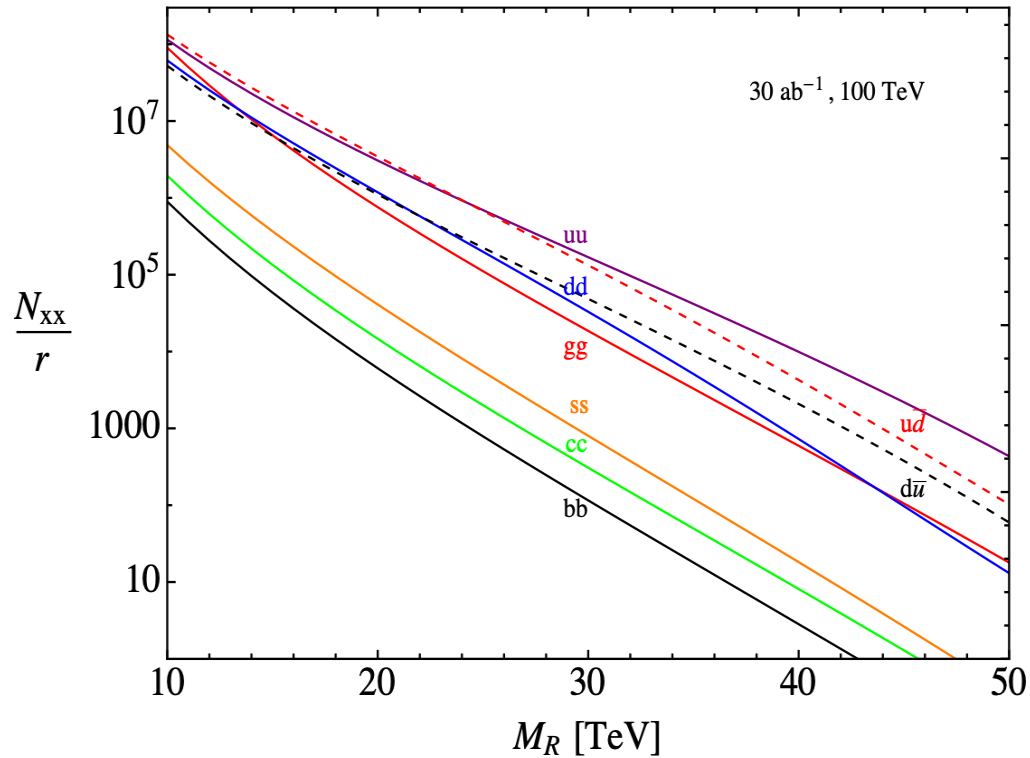

Plot from mid-term report

FCC-hh Simulation (Delphes), $\sqrt{s} = 100$ TeV

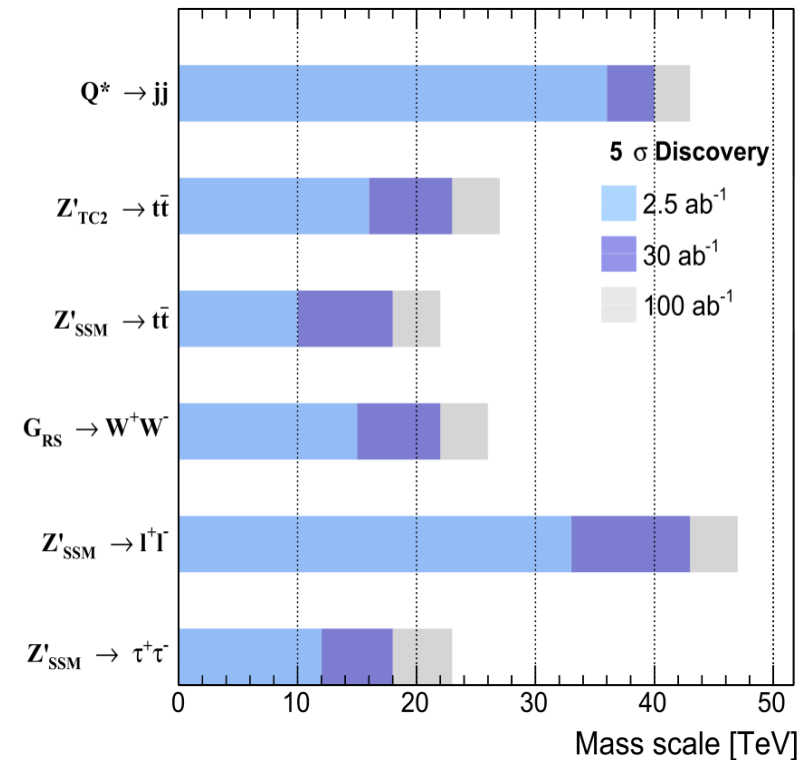

Plot from FCC CDR

FCC-hh effectively collides 196 different initial states, perfect exploratory machine

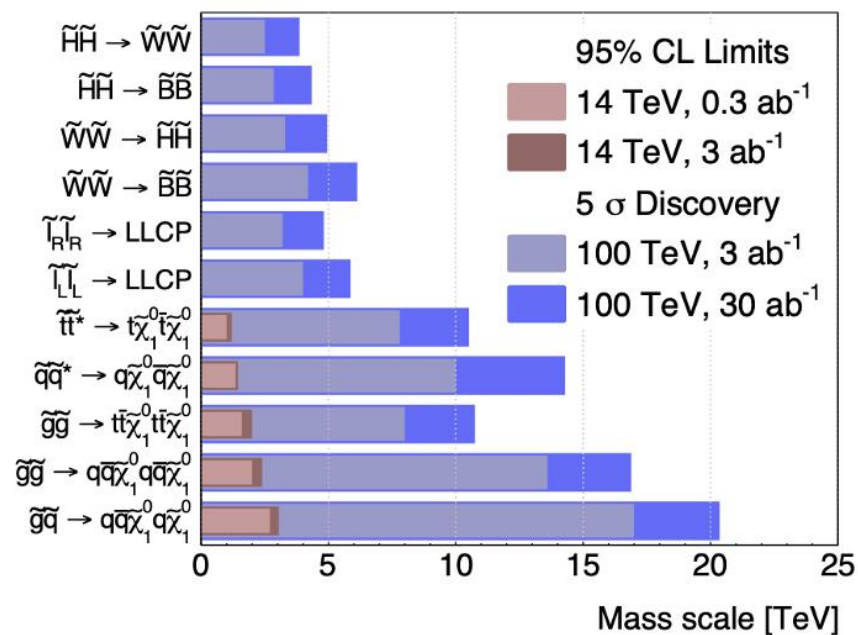

Plot from [arXiv:1606.00947](https://arxiv.org/abs/1606.00947)

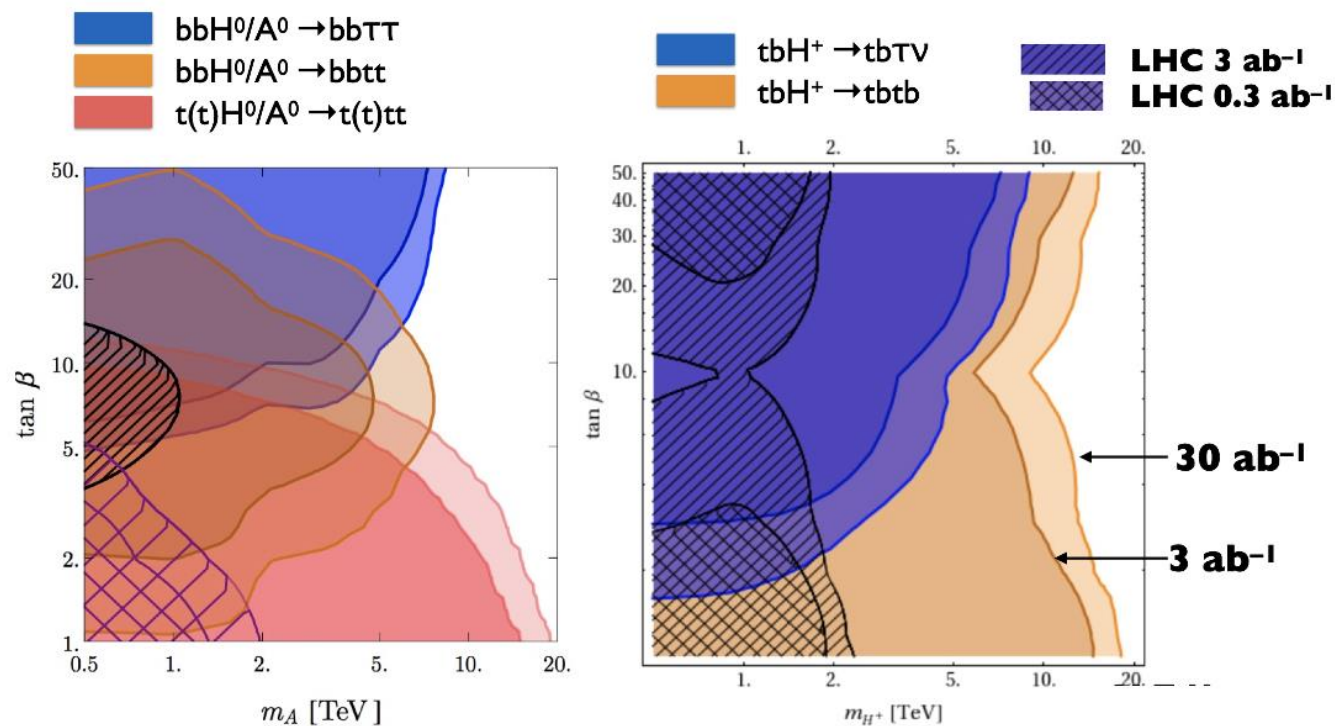

Plot from [arXiv:1605.08744](https://arxiv.org/abs/1605.08744) and [arXiv:1504.07617](https://arxiv.org/abs/1504.07617)

2013 Update of European Strategy for Particle Physics:

“CERN should undertake design studies for accelerator projects in a global context, with emphasis on proton-proton and electron-positron high-energy frontier machines.”

→ FCC Conceptual Design Reports (2018/19)



Vol 1 Physics, Vol 2 FCC-ee, Vol 3 FCC-hh, Vol 4 HE-LHC

CDRs published in **European Physical Journal C (Vol 1)** and **ST (Vol 2 – 4)**

EPJ C 79, 6 (2019) 474 , EPJ ST 228, 2 (2019) 261-623 ,
EPJ ST 228, 4 (2019) 755-1107 , EPJ ST 228, 5 (2019) 1109-1382

2020 Update of European Strategy for Particle Physics:

“Europe, together with its international partners, should investigate technical and financial feasibility of a future hadron collider at CERN with a centre-of-mass energy of at least 100 TeV and with an electron-positron Higgs and electroweak factory as a possible first stage.”

High-level Goals of Feasibility Study

High-level goals of Feasibility Study

- optimisation of placement and layout of the ring and related infrastructure, and demonstration of the geological, technical, environmental and administrative feasibility of the tunnel and surface areas;
- pursuit, together with the Host States, of the preparatory administrative processes required for a potential project approval, with a focus on identifying and surmounting possible showstoppers;
- optimisation of the design of the colliders and their injector chains, supported by targeted R&D to develop the needed key technologies;
- development and documentation of the main components of the technical infrastructure;
- elaboration of a sustainable operational model for the colliders and experiments in terms of human and financial resource needs, environmental aspects and energy efficiency;
- identification of substantial resources from outside CERN's budget for the implementation of the first stage of a possible future project;
- consolidation of the physics case and detector concepts for both colliders.

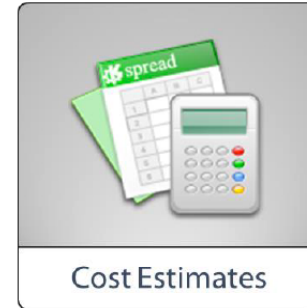
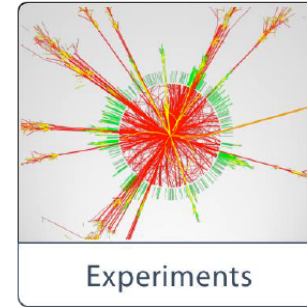
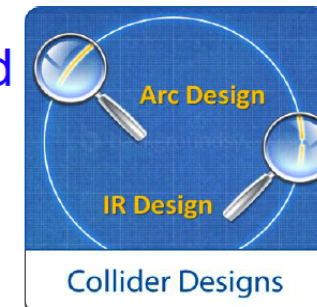
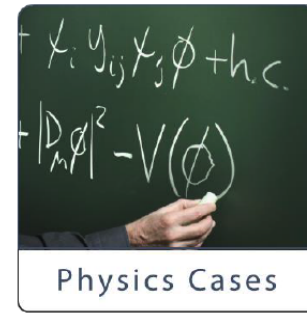
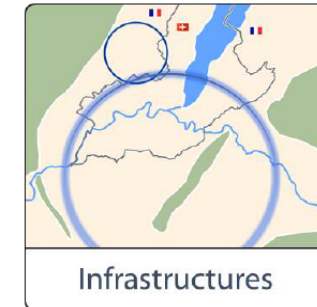

FCC Integrated Programme - Timeline

Note: FCC Conceptual Design Study started in 2014 leading to CDR in 2018

FCC construction can proceed in parallel with HL-LHC operation.

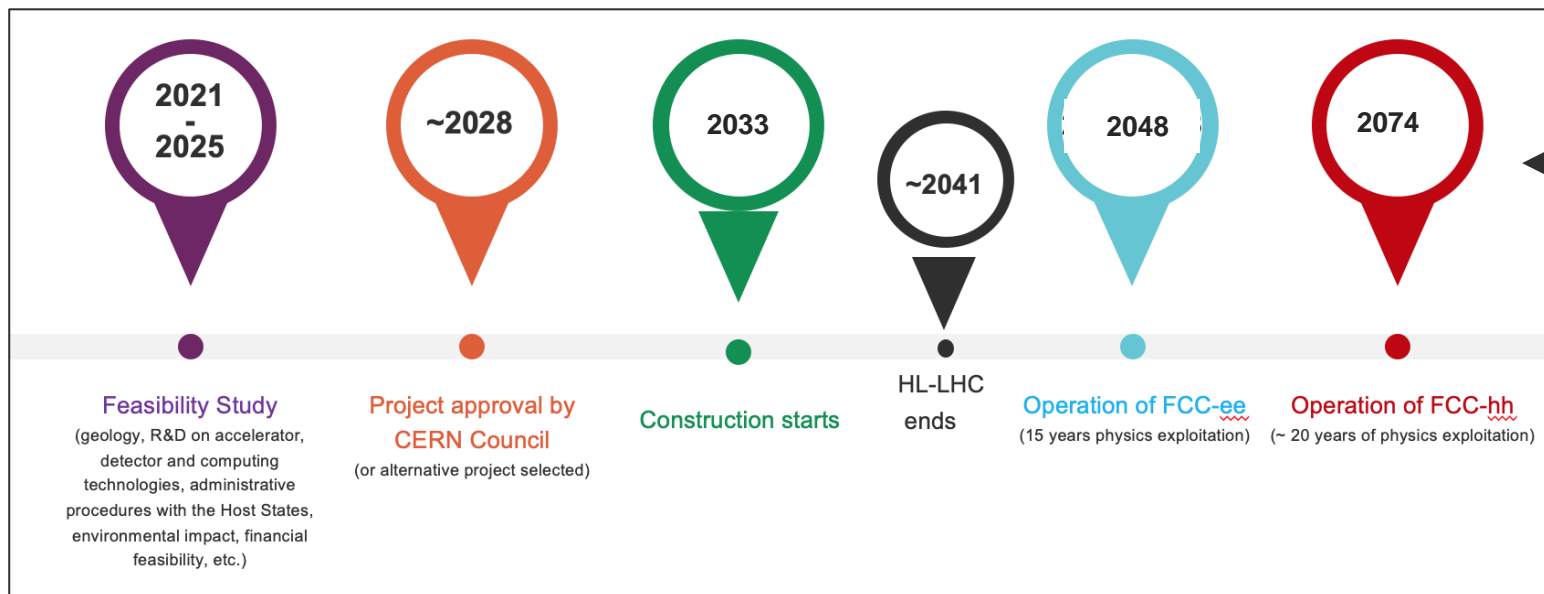
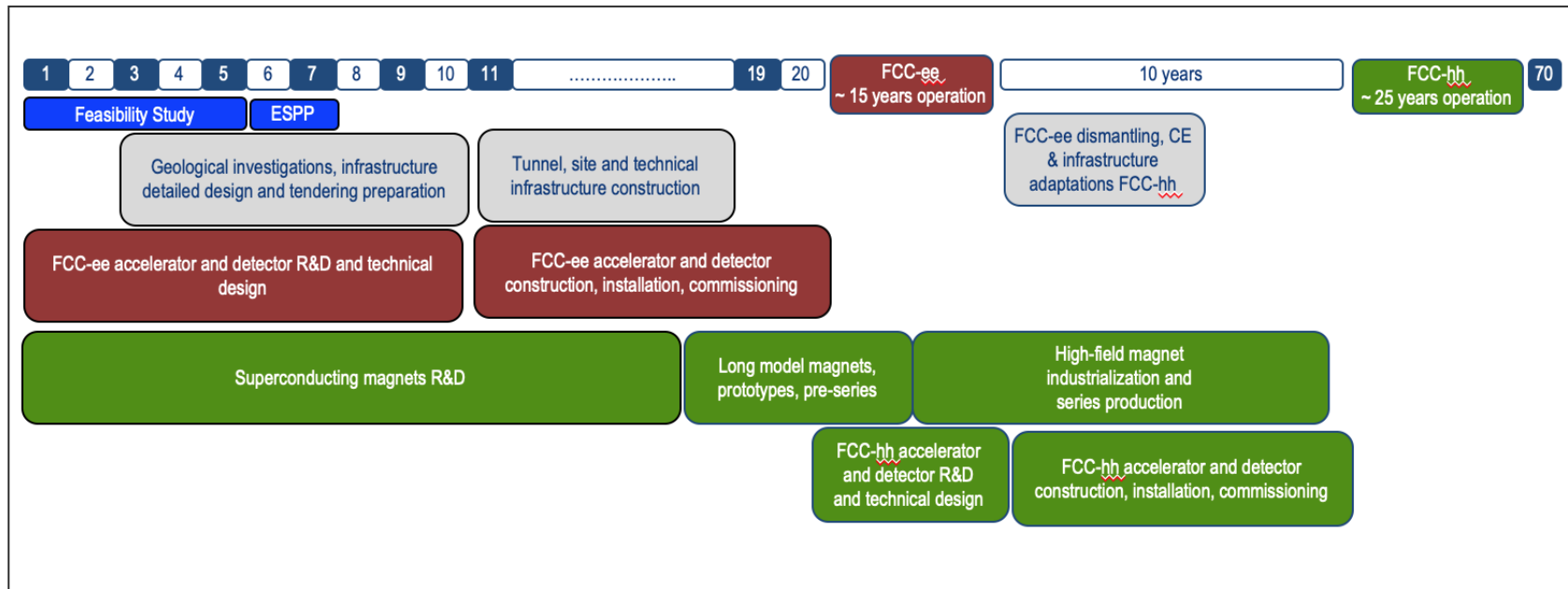

“Realistic” schedule taking into account:

- past experience in building colliders at CERN
- approval timeline: ESPP, Council decision
- that HL-LHC will run until 2041

Can be accelerated if more resources available

FCC-ee in a Nutshell

- **High luminosity precision study of Z, W, H, and $t\bar{t}$**
 - $2 \times 10^{36} \text{ cm}^{-2}\text{s}^{-1}/\text{IP}$ at Z (or total $\sim 10^{37} \text{ cm}^{-2}\text{s}^{-1}$ with 4 IPs)
 - $7 \times 10^{34} \text{ cm}^{-2}\text{s}^{-1}$ at ZH, $1.3 \times 10^{34} \text{ cm}^{-2}\text{s}^{-1}$ at $t\bar{t}$
 - Unprecedented energy resolution at Z (<100 keV) and W (<300 keV)
- **Low-risk technical solution** based on 60 years of e^+e^- circular colliders and particle detectors ; R&D on components for improved performance, but no need for “demonstration” facilities; LEP2, VEPP-4M, PEP-II, KEKB, DAΦNE, or SuperKEKB already used many of the key ingredients in routine operation
- Infrastructure will support a **century of exciting physics of discovery**
 - FCC-ee \rightarrow FCC-hh \rightarrow FCC-eh and/or several other options (FCC- $\mu\mu$, Gamma Factory ..)
- **Utility requirements** similar to CERN existing use
- **Strong support** from CERN, partners & particle physics roadmaps (Europe, US)
- **Detailed multi-domain feasibility study underway** for next European Strategy

Based on lessons and techniques from past colliders (last 40 years)

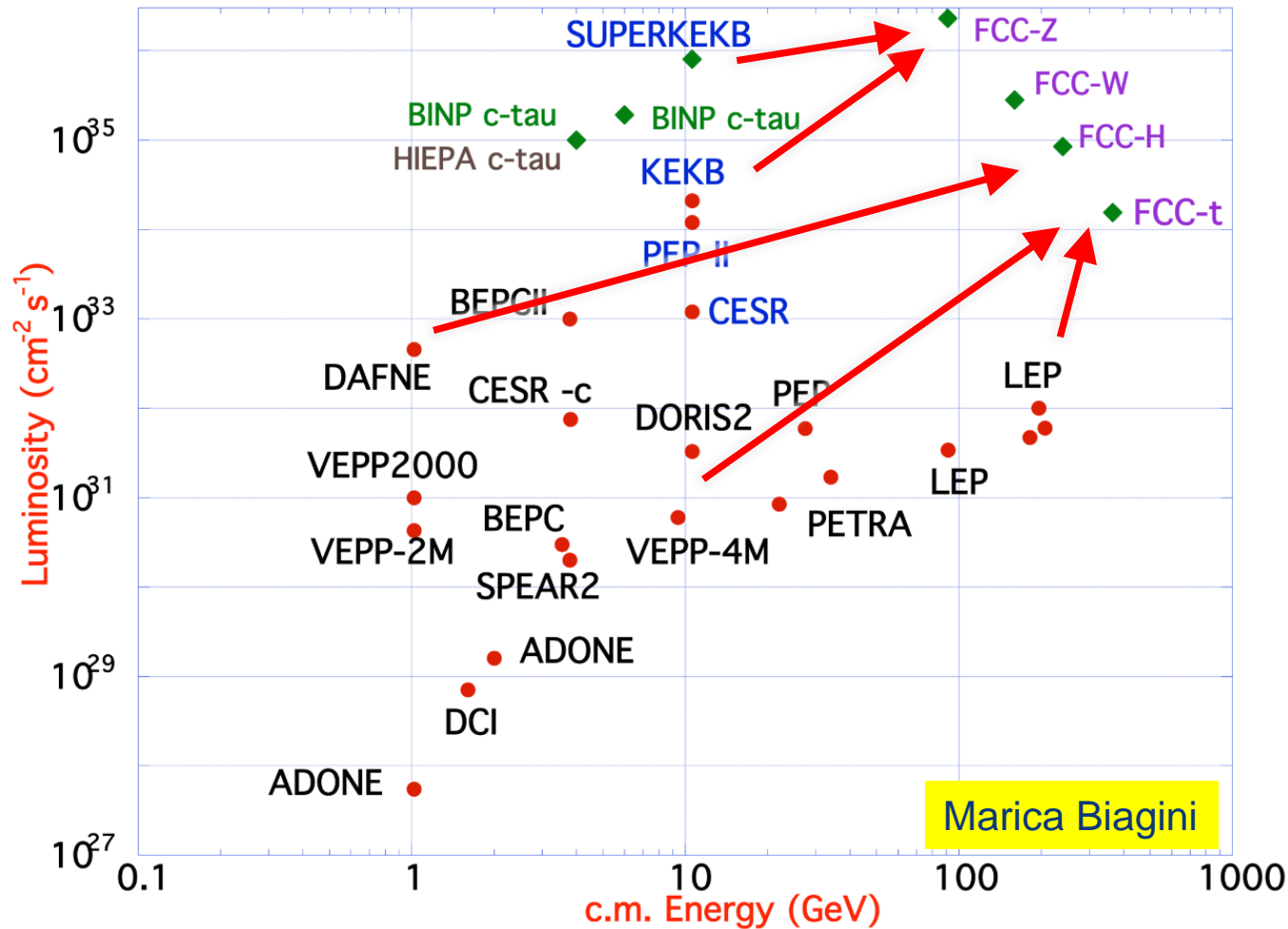

B-factories: KEKB & PEP-II:

**double-ring lepton colliders,
high beam currents,
top-up injection**

DAFNE: crab waist, double ring

S-KEKB: low β_y^* , crab waist

LEP: high energy, SR effects

VEPP-4M, LEP: precision E calibration

KEKB: e^+ source

HERA, LEP, RHIC: spin gymnastics

Marica Biagini

combining successful ingredients of several recent colliders → highest luminosities & energies

Parameter	Z	WW	H (ZH)	ttbar
beam energy [GeV]	45.6	80	120	182.5
beam current [mA]	1270	137	26.7	4.9
number bunches/beam	11200	1780	440	60
bunch intensity [10^{11}]	2.14	1.45	1.15	1.55
SR energy loss / turn [GeV]	0.0394	0.374	1.89	10.4
total RF voltage 400/800 MHz [GV]	0.120/0	1.0/0	2.1/0	2.1/9.4
long. damping time [turns]	1158	215	64	18
horizontal beta* [m]	0.11	0.2	0.24	1.0
vertical beta* [mm]	0.7	1.0	1.0	1.6
horizontal geometric emittance [nm]	0.71	2.17	0.71	1.59
vertical geom. emittance [pm]	1.9	2.2	1.4	1.6
horizontal rms IP spot size [μm]	9	21	13	40
vertical rms IP spot size [nm]	36	47	40	51
beam-beam parameter ξ_x / ξ_y	0.002/0.0973	0.013/0.128	0.010/0.088	0.073/0.134
rms bunch length with SR / BS [mm]	5.6 / 15.5	3.5 / 5.4	3.4 / 4.7	1.8 / 2.2
luminosity per IP [$10^{34} \text{ cm}^{-2}\text{s}^{-1}$]	140	20	5.0	1.25
total integrated luminosity / IP / year [ab^{-1}/yr]	17	2.4	0.6	0.15
beam lifetime rad Bhabha + BS [min]	15	12	12	11

Design and parameters dominated by the choice to allow for 50 MW synchrotron radiation per beam.

4 years
 5×10^{12} Z
 LEP $\times 10^5$

2 years
 $> 10^8$ WW
 LEP $\times 10^4$

3 years
 2×10^6 H

5 years
 2×10^6 tt pairs

- Up to x2000 improvement on all EW observables
- Up to x10 improvement on Higgs coupling (model-indep.) measurements over HL-LHC
- x10 Belle II statistics for b, c, τ
- indirect discovery potential up to ~ 70 TeV
- direct discovery potential for feebly-interacting particles over 5-100 GeV mass range

Up to 4 interaction points \rightarrow robustness, statistics, possibility of specialised detectors to maximise physics output

Efficient RF power sources (400 & 800 MHz)

I. Syrathev

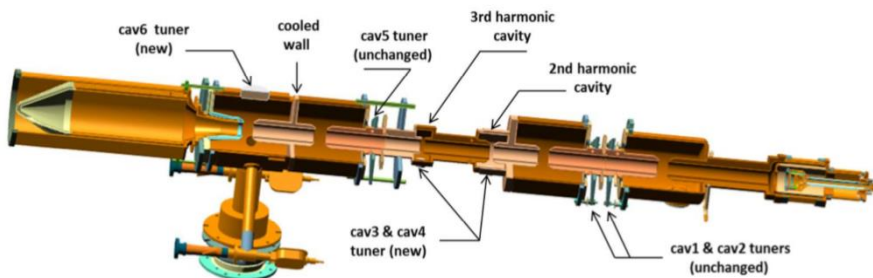

400 MHz
1-,2- & 4-
cell
Nb/Cu ,
4.5 K

FPC & HOM coupler, cryomodule,
thin-film coatings...

Energy efficient twin aperture arc dipoles

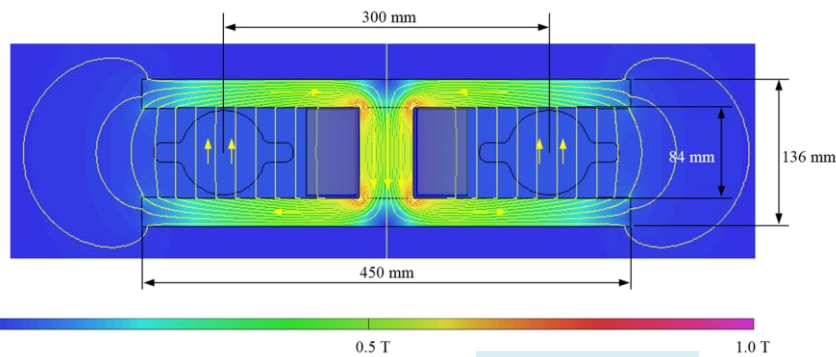
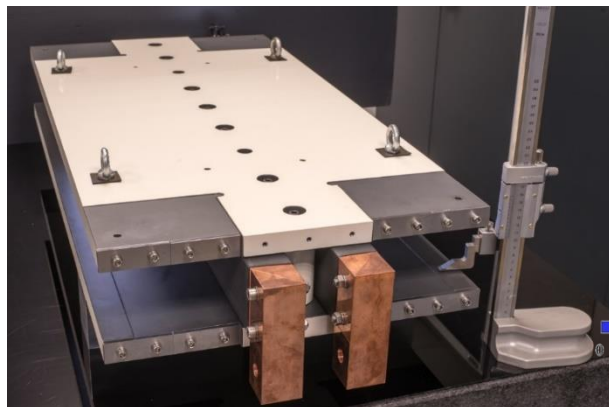

A. Milanese

Efficient SC cavities



800 MHz 5-cell Nb
prototype / JLAB, 2 K

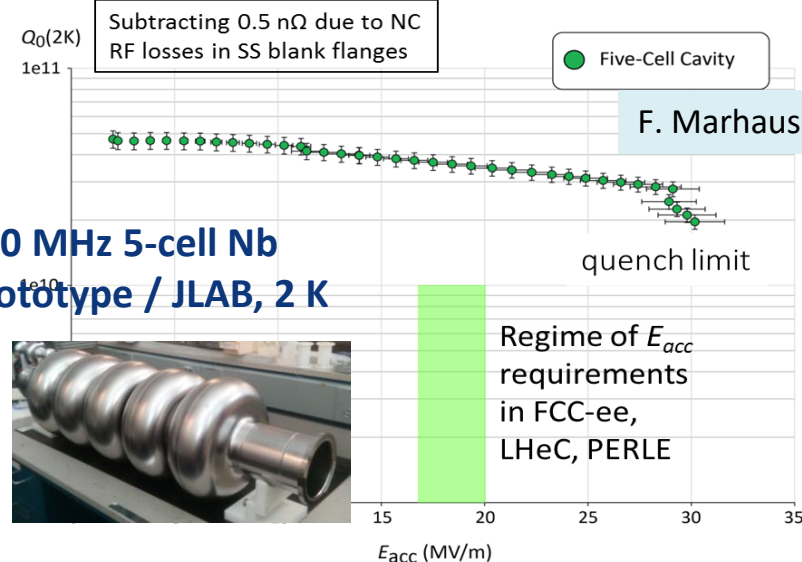

Jefferson Lab

Under study: CCT HTS quad's & sext's for arcs

PAUL SCHERRER INSTITUT
PSI

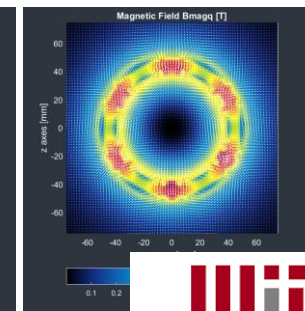
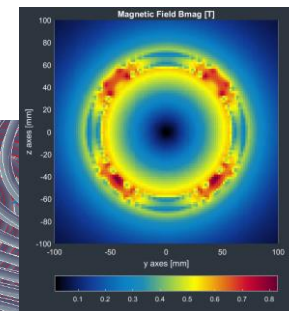
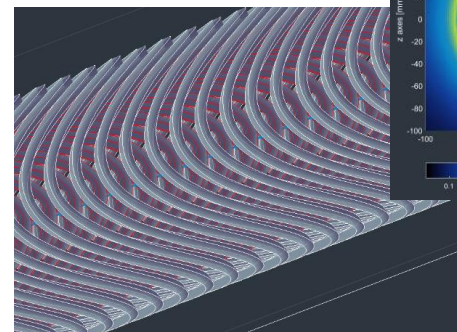

M. Koratzinos

MIT
Massachusetts
Institute of
Technology

Optimised Placement and Lay-out for Feasibility Study

Layout chosen out of ~ 100 initial variants, based on **geology** and **surface constraints** (land availability, access to roads, etc.), **environment**, (protected zones), **infrastructure** (water, electricity, transport), **machine performance** etc.

“**Avoid-reduce-compensate**” principle of EU and French regulations

Overall lowest-risk baseline: 90.7 km ring, 8 surface points,
Whole project now adapted to this placement

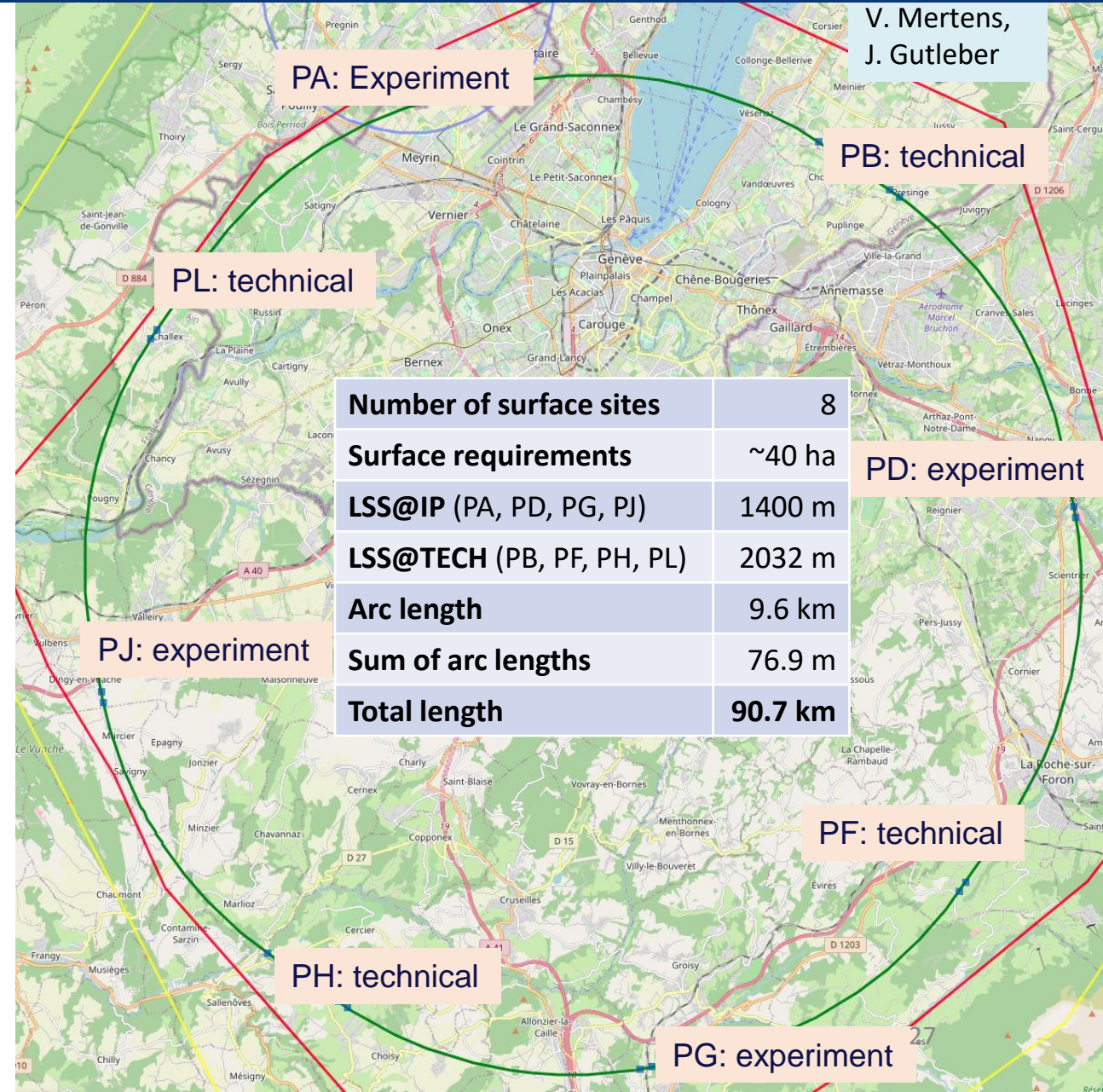
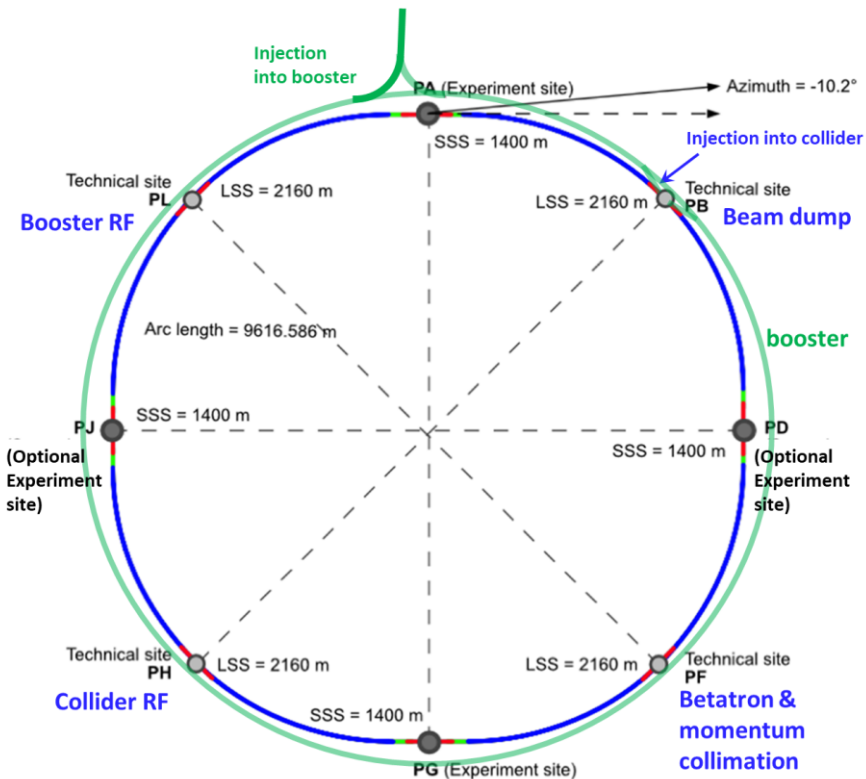

Number of surface sites	8
Surface requirements	~40 ha
LSS@IP (PA, PD, PG, PJ)	1400 m
LSS@TECH (PB, PF, PH, PL)	2032 m
Arc length	9.6 km
Sum of arc lengths	76.9 m
Total length	90.7 km

V. Mertens,
J. Gutleber

PA: Experiment

PB: technical

PL: technical

PD: experiment

PJ: experiment

PF: technical

PH: technical

PG: experiment

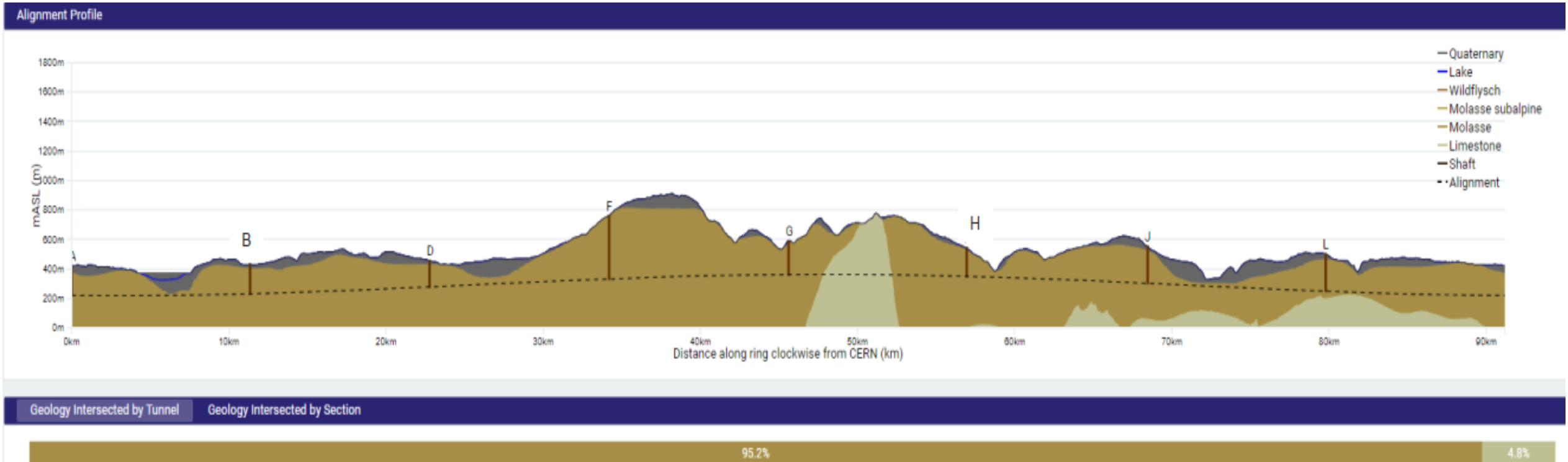

Tunnel implementation summary

- 91 km circumference
- 95% in molasse geology for minimising tunnel construction risks
- Site investigations in zones where tunnel is close to geological interfaces: moraines-molasse-limestone

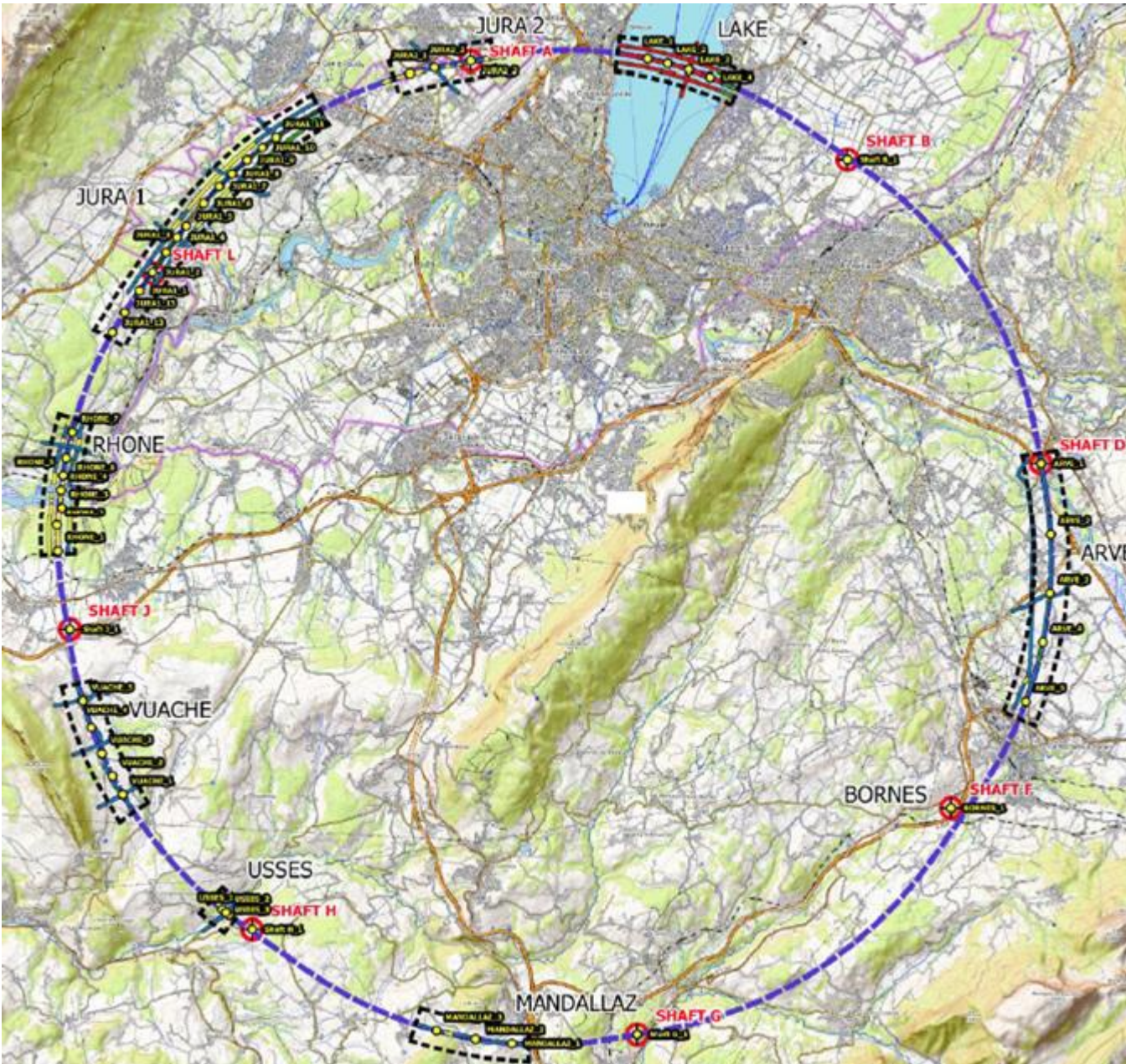

- **Site investigations in areas with uncertain geological conditions:**
 - Optimisation of localisation of drilling locations ongoing with site visits since end 2022.
 - **Alignment with FR and CH on the process for obtaining autorisation procedures. Ongoing for start of drillings in Q2/2024.**
- **Contracts Status:**
 - Contract for engineering services and role of Engineer during works, active since July 2022
 - Site investigations tendering ongoing towards contract placement in December 2023 and mobilization from January 2024.



Sondage A89 (2007) incliné de 45° de 125 ml (surface plateforme estimée: 12 x 12 m soit environ 150 m²)



Drilling works on the lake

An innovative local approach for excavated materials

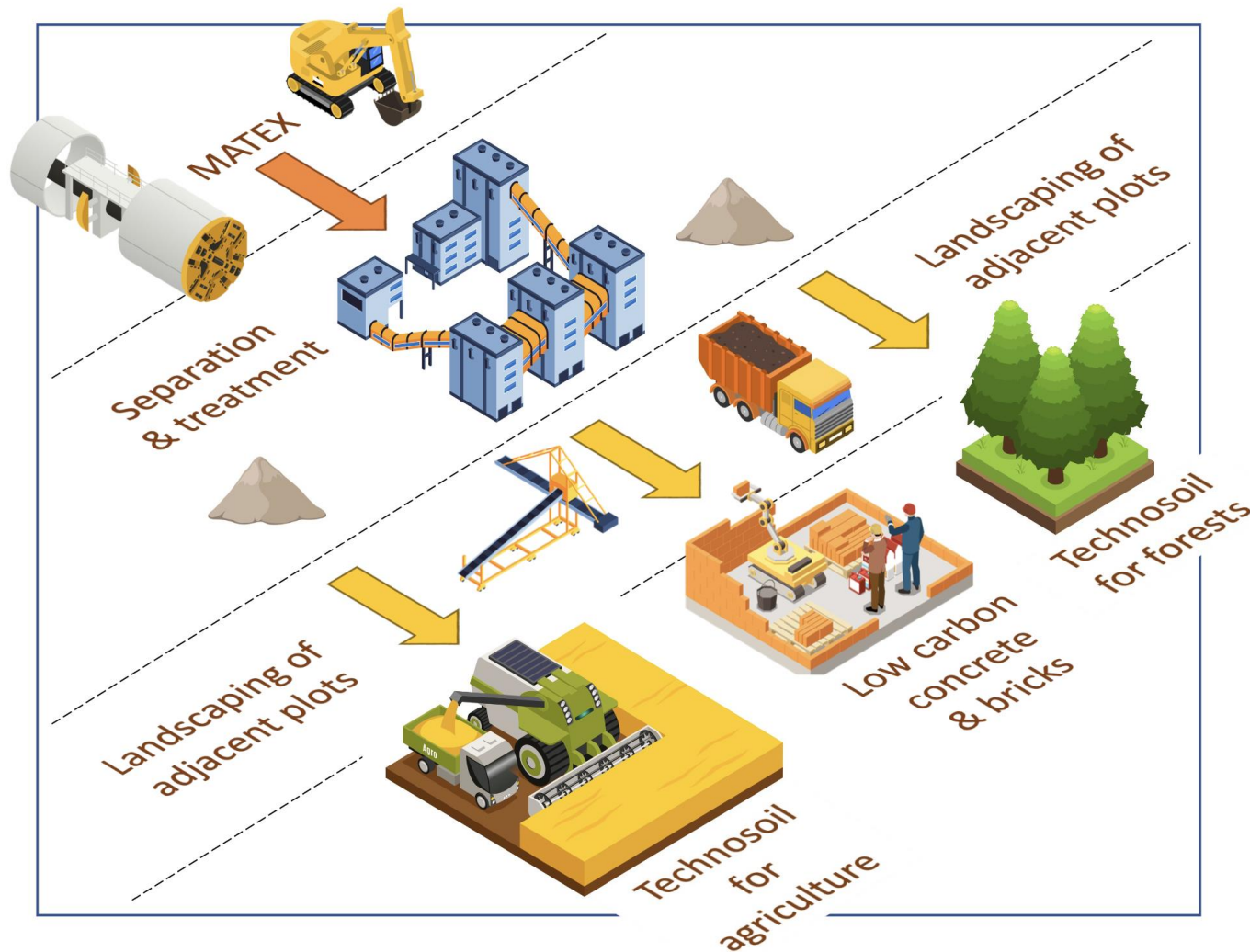

- Excavated material from FCC subsurface infrastructures: 6.5 Mm³ in situ, 8.4 Mm³ excavated (bulk factor 1.3)
- **2021-2022: International competition “Mining the Future”**, launched with the support of the EU Horizon 2020 grant agreement 951754, to **find innovative and realistic ideas for the reuse of Molasse** (96% of excavated materials)
- **2023: Definition of the “OpenSky Laboratory” project:**
 - Objective: Develop and test an innovative process to transform sterile “molasse” into fertile soil for agricultural use and afforestation.
 - Duration: 4 years (2024-2027)

GOAL: demonstrate the feasibility to transform Molasse (excavated material) into fertile soil.

- Project launched in January 2024
- 5500 m² near LHC P5 in Cessy, France.
- Trial with 5 000 t of excavated local molasse

Layout :

- cells for agriculture trials (10*10 m)
- cells for forestry trials (20*20 m)

Different types of plants selected in function of regional specificities and possible soil reuse cases

Project phases:

- 1) Initial laboratory analysis to **identify** the **most suitable mix** of molasse and amendments.
- 2) **Field tests** in a **controlled environment** (**monitoring** of the field conditions)

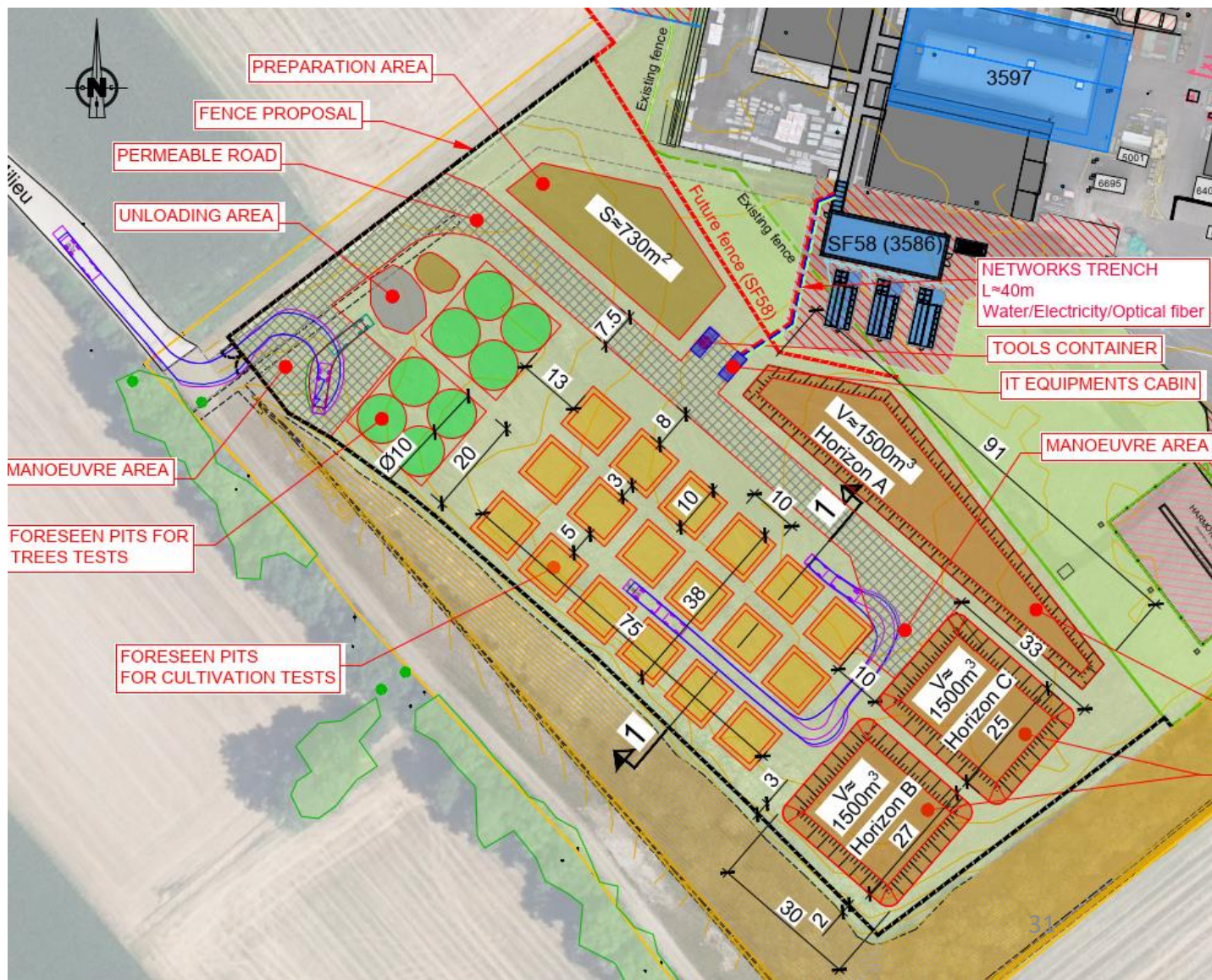

FCC-hh: Highest Collision Energies

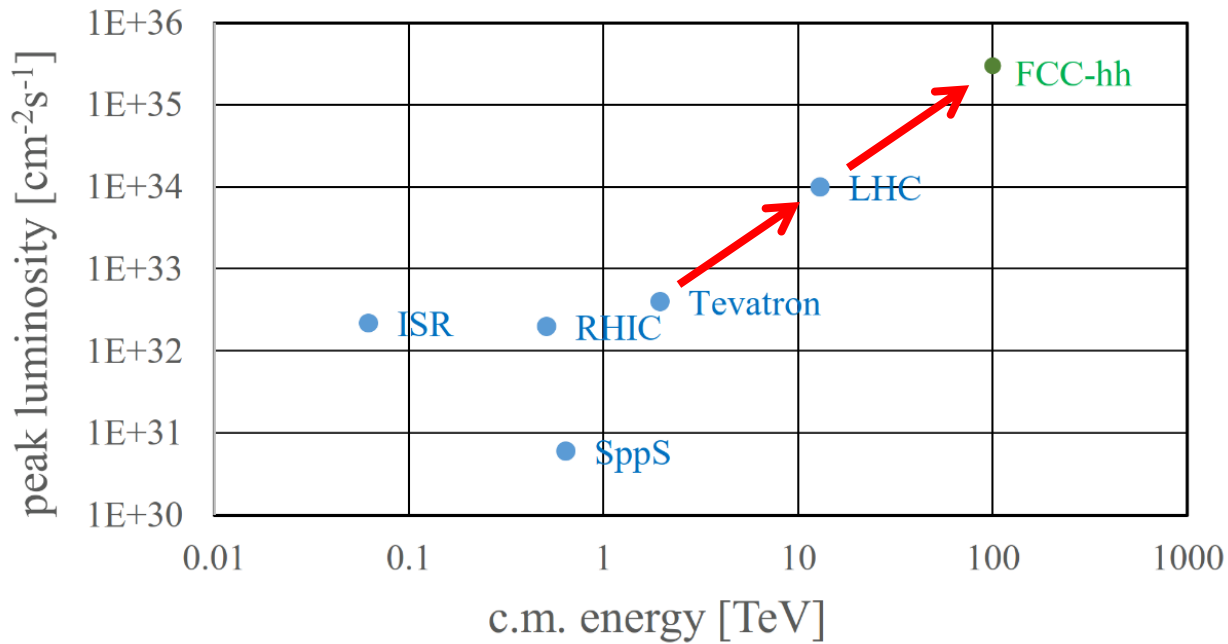

- **Order of magnitude performance increase** in both **energy & luminosity**
- **100 TeV collision energy** (vs 14 TeV for LHC)
- **20 ab^{-1} per experiment collected over 25 years** of operation (vs 3 ab^{-1} for LHC)
- Similar performance increase as from Tevatron to LHC
- **Key technology: high-field magnets**

from
LHC technology
8.3 T NbTi dipole

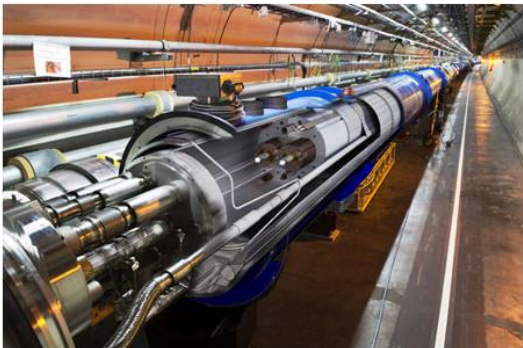

via
HL-LHC technology
12 T Nb_3Sn quadrupole

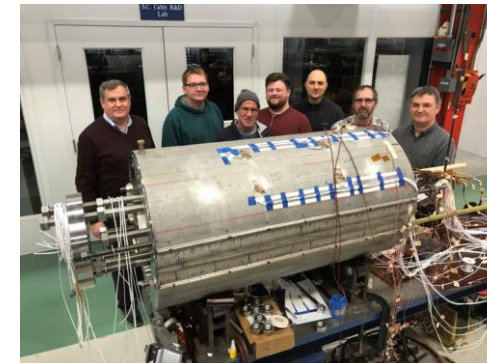

FNAL dipole
demonstrator
14.5 T Nb_3Sn

FCC-hh – Main Machine Parameters

parameter	FCC-hh	HL-LHC	LHC
collision energy cms [TeV]	81 - 115		14
dipole field [T]	14 - 20		8.33
circumference [km]	90.7		26.7
arc length [km]	76.9		22.5
beam current [A]	0.5	1.1	0.58
bunch intensity [10^{11}]	1	2.2	1.15
bunch spacing [ns]	25		25
synchr. rad. power / ring [kW]	1020 - 4250	7.3	3.6
SR power / length [W/m/ap.]	13 - 54	0.33	0.17
long. emit. damping time [h]	0.77 – 0.26		12.9
peak luminosity [$10^{34} \text{ cm}^{-2}\text{s}^{-1}$]	~30	5 (lev.)	1
events/bunch crossing	~1000	132	27
stored energy/beam [GJ]	6.1 - 8.9	0.7	0.36
Integrated luminosity/main IP [fb^{-1}]	20000	3000	300

With FCC-hh after FCC-ee:
significantly
more time for high-field
magnet R&D
aiming at highest possible
energies

Formidable challenges:

- high-field superconducting magnets: 14 - 20 T**
- power load** in arcs from **synchrotron radiation: 4 MW** → cryogenics, vacuum
- stored beam energy: ~ 9 GJ** → machine protection
- pile-up** in the detectors: **~1000 events/xing**
- energy consumption: 4 TWh/year** → R&D on cryo, HTS, beam current, ...

Formidable physics reach, including:

- Direct discovery potential up to ~ 40 TeV**
- Measurement of Higgs self to ~ 5% and ttH to ~ 1%
- High-precision and model-indep** (with FCC-ee input)
measurements of rare Higgs decays ($\gamma\gamma, Z\gamma, \mu\mu$)₃₃
- Final word about WIMP dark matter**

PSI Nb₃Sn CCT «CD1» main test carried out in 2022/23

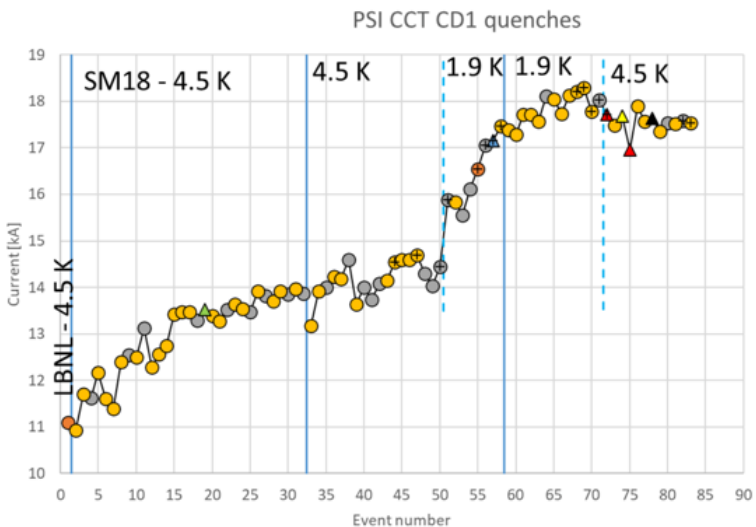

It trained A LOT. It reached 100% of maximum field at 4.5 K. No conductor degradation occurred from handling, assembly, powering, or thermal cycling.

Stress-management works, CD1 is a robust magnet.

B. Auchmann

Next: FCC-hh SM-CC Demonstrator

Goal: demonstrate robust & cost-efficient Nb₃Sn technology for next European Strategy update.

Novel concept: Stress-managed and asymmetric common coils.

- Stainless steel shell
- Iron yoke
- Coil collar
- Former
- Non-magnetic poles
- Nb₃Sn conductor



B₀ target of 14 T, at T_{op}: 4.2 K
Eng margin of 10%
B₀ short sample @ 1.9 K: 16 T

D. Araujo

Rough estimates

Bottom line: HTS technology must catch up over the coming 10 years in TRL to LTS

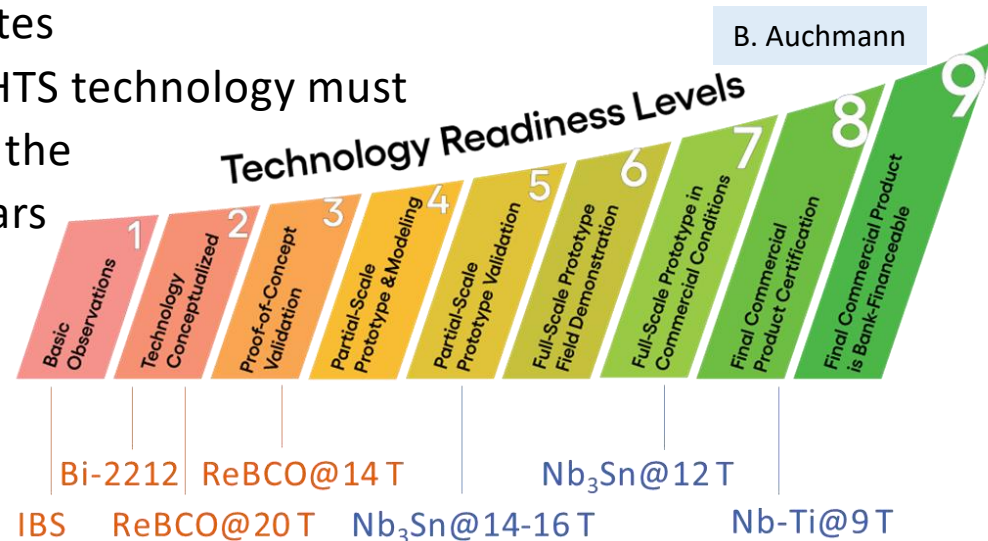

HTS Innovation Funnel for HFM

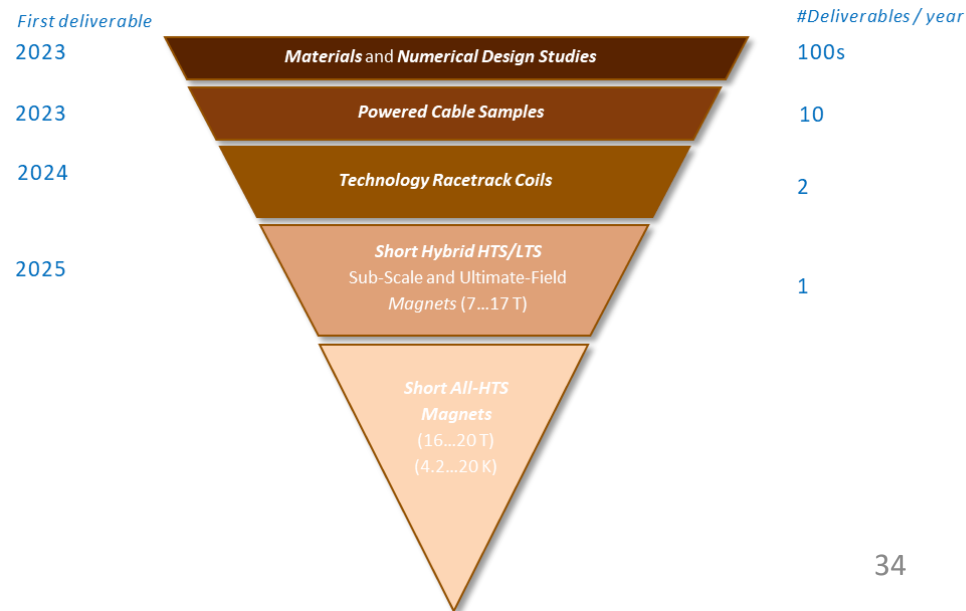

Regular Arc Tunnel Cross-section & Element Integration

FCC-ee

FCC-hh

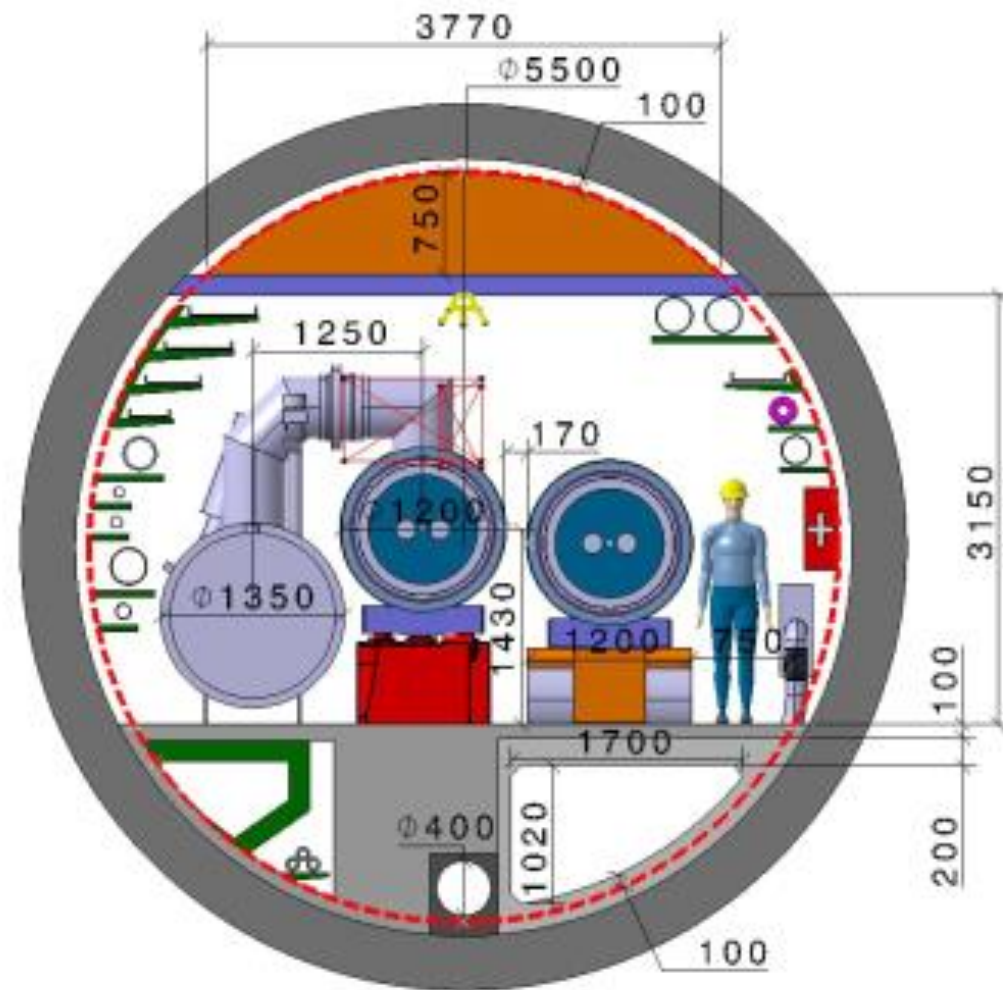
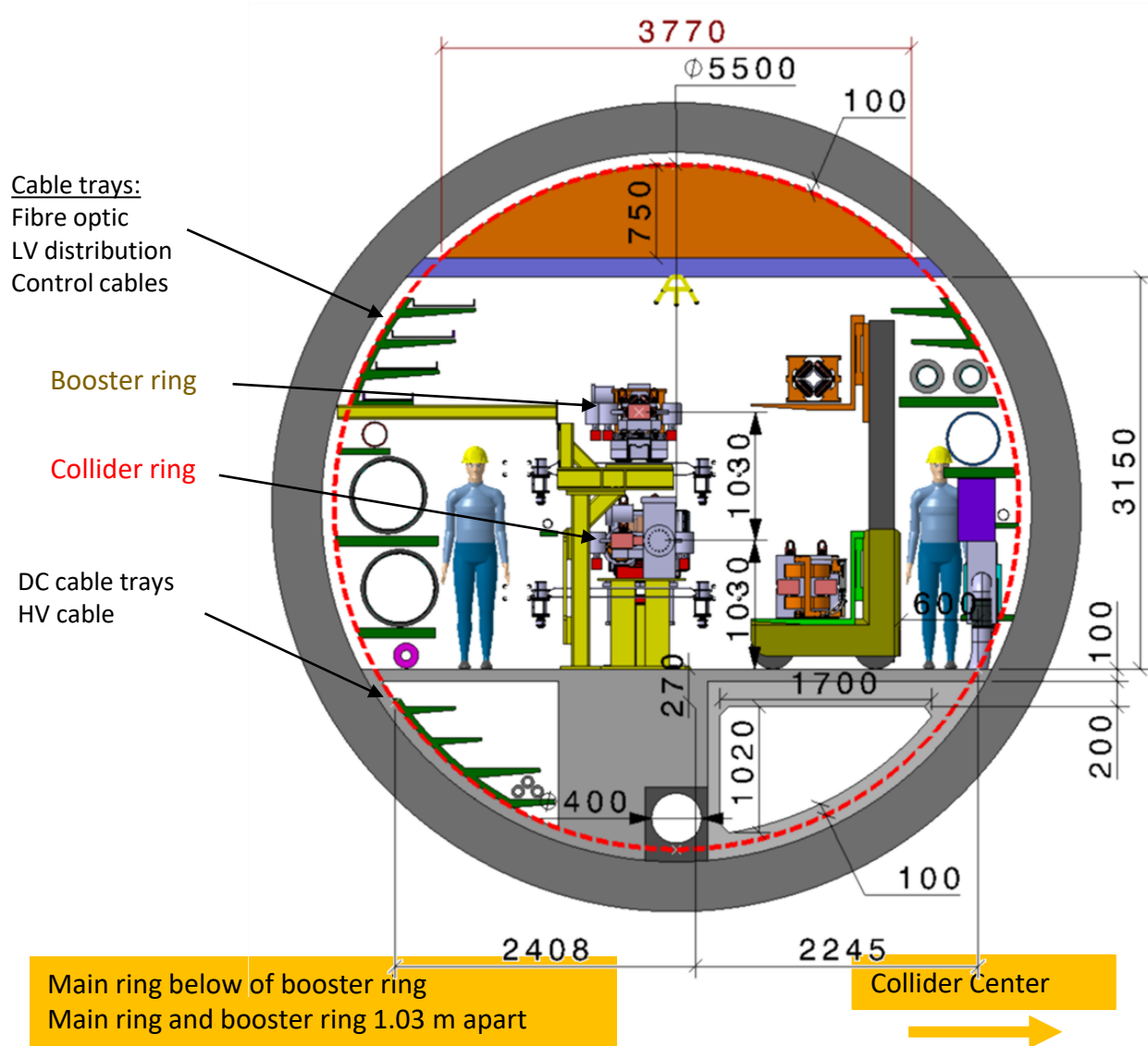

Collider Center

35

Detectors Under Study for FCC-ee

CLD

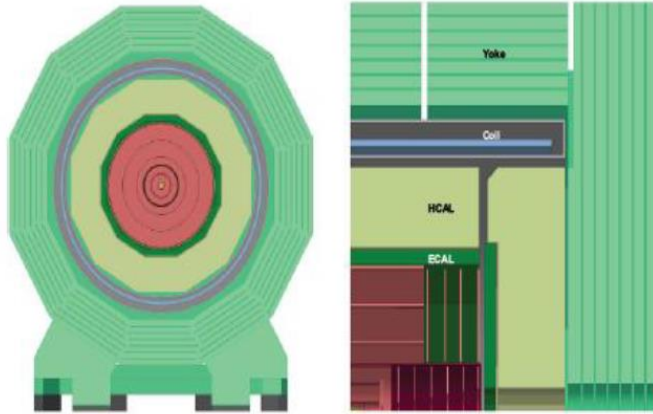

- conceptually extended from the CLIC detector design
- full silicon tracker
- 2T magnetic field
- high granular silicon-tungsten ECAL
- high granular scintillator-steel HCAL
- instrumented steel-yoke with RPC for muon detection

IDEA

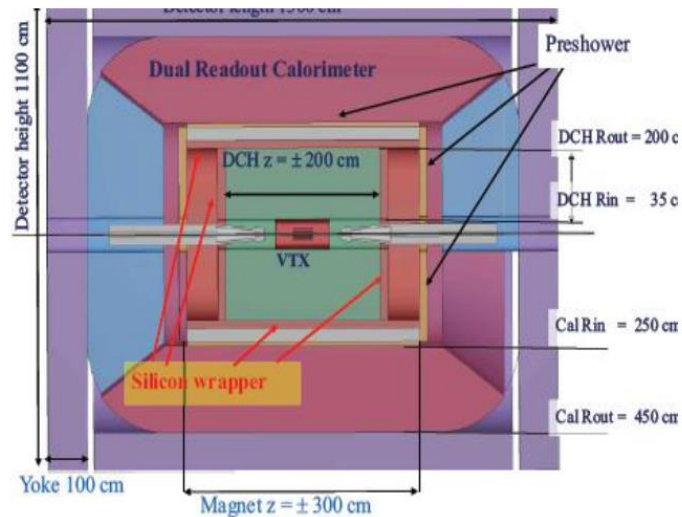

- explicitly designed for FCC-ee/CepC
- silicon vertex
- low X_0 drift chamber
- drift-chamber silicon wrapper
- MPGD/magnet coil/lead preshower
- dual-readout calorimeter: lead-scintillating/cerenkov fibers

Noble Liquid ECAL



- explicitly designed for FCC-ee, recent concept, under development
- silicon vertex
- Low X_0 drift chamber
- Thin Solenoid before the Calorimeter
- High Granularity Liquid Argon Calorimetry

But several other options like Crystal Calorimetry (active in US, Italy), are under study (similarly for tracking, muons and particle ID) and Time Projection Chamber (TPC) of ILD

With potentially 4 experiments, many complementary options will be implemented, Definitely a place to contribute

Energy and Carbon Footprint

- **Our first responsibility (as particle physicists) is to do the maximum of science**
 - ◆ **With the minimal energy consumption and the minimal environmental impact for our planet**
 - Should become one of our top-level decision criteria for design, choice and optimization of a collider

- **All Higgs factories have a “similar” physics outcome**
 - ◆ **Natural question: what is their energy consumption or carbon footprint for the same physics outcome?**
 - Circular colliders have a much larger instantaneous luminosity and operate several detectors
 - FCC-ee is at CERN, where electricity is already almost carbon-free (and will be even more so in 2048)

arXiv:2208.10466

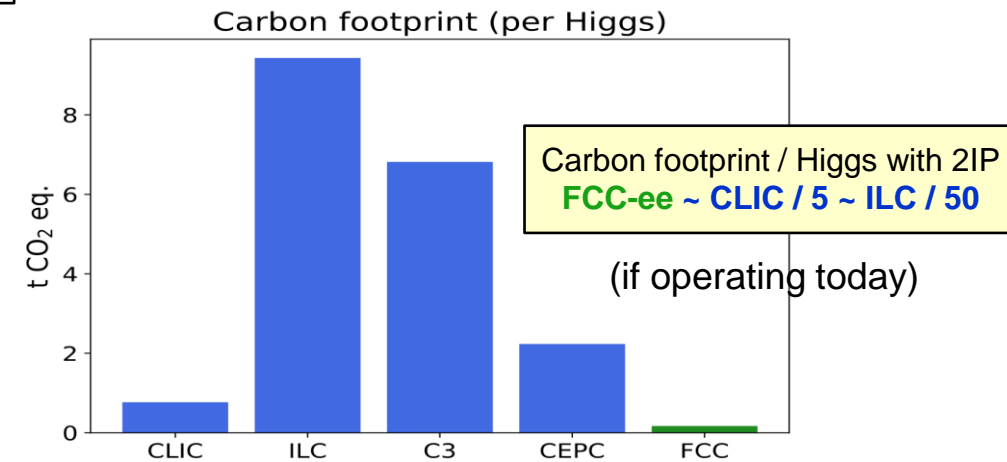
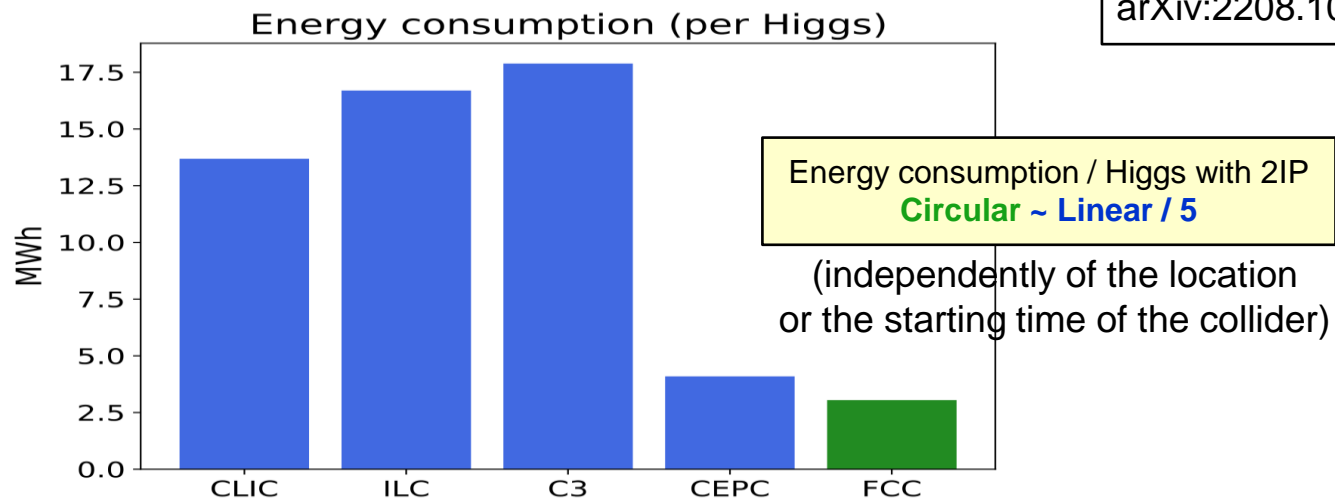

First part of FCC Feasibility Study completed successfully with the Mid-term Review

- 20 – 22 November 2023: SPC and FC review meetings on mid-term review
- 2 February 2024: CERN Council meeting on mid-term review

Focus 2021 - 2023:

- Identify best placement & layout and adapting entire project to new placement.
- This provided the input for the mid-term review documentation and cost estimate update.

Fruitful collaboration between scientific & technical actors, in close cooperation with the CERN Host State services, at departmental/cantonal and local level. Direct exchange in place with communes concerned by surface sites. Environmental studies ongoing.

Focus 2024 - 2025:

- Subsurface investigations, further optimisation of implementation, surface sites, synergies, etc.
- Full design iteration in view of technical and cost optimisation of entire project.
- Cost containment and reduction of cost uncertainties, development of risk register.
- Further development of an affordable funding model and related governance implications (with Council).
- Environmental impact (civil engineering, excavated materials, sustainability); geological investigations
- Completion of the FCC Feasibility Study in 2025.

FCC Preliminary Budget

- The **total estimated cost for FCC-ee with 4 experimental points that could run across 4 different energy stages (from 90 to 360 GeV) is 15 BCHF over ~10 years and across CERN's Member States, Associate Member States as well as international partners (non-Member States / Observer States).**
- These facilities are planned to be used initially for FCC-ee and take into account any **specific requirements for a future FCC-hh machine.**
- Large parts will return via **procurement to industries** of participating countries.
- **Current uncertainties will be reduced further** by the completion of the FCC Feasibility Study in 2025.

- The path to the **governance structure** required for the FCC project and operation phases is both **exciting and challenging**.
- Requires the **long-term engagement and support** of participants from CERN's Member, Associate Member & non-Member States.
- As the project evolves further, it is crucial to **refine and adapt the collaboration model** to ensure the efficient allocation of resources and sustained momentum.
- The **collaborative spirit** that defines the FCC promises to shape the **future of particle physics**.
- **First discussions** on the governance considerations for the FCC project are taking place in the **CERN Council**.

- **Ownership** of the Feasibility Study by the Council.
- Effective and timely **supervision**.
- Integration of scientific and technical **advice**.
- **Participation of stakeholders** that can potentially make significant financial and technical contributions to a possible future project.
- **Execution** of Feasibility Study.

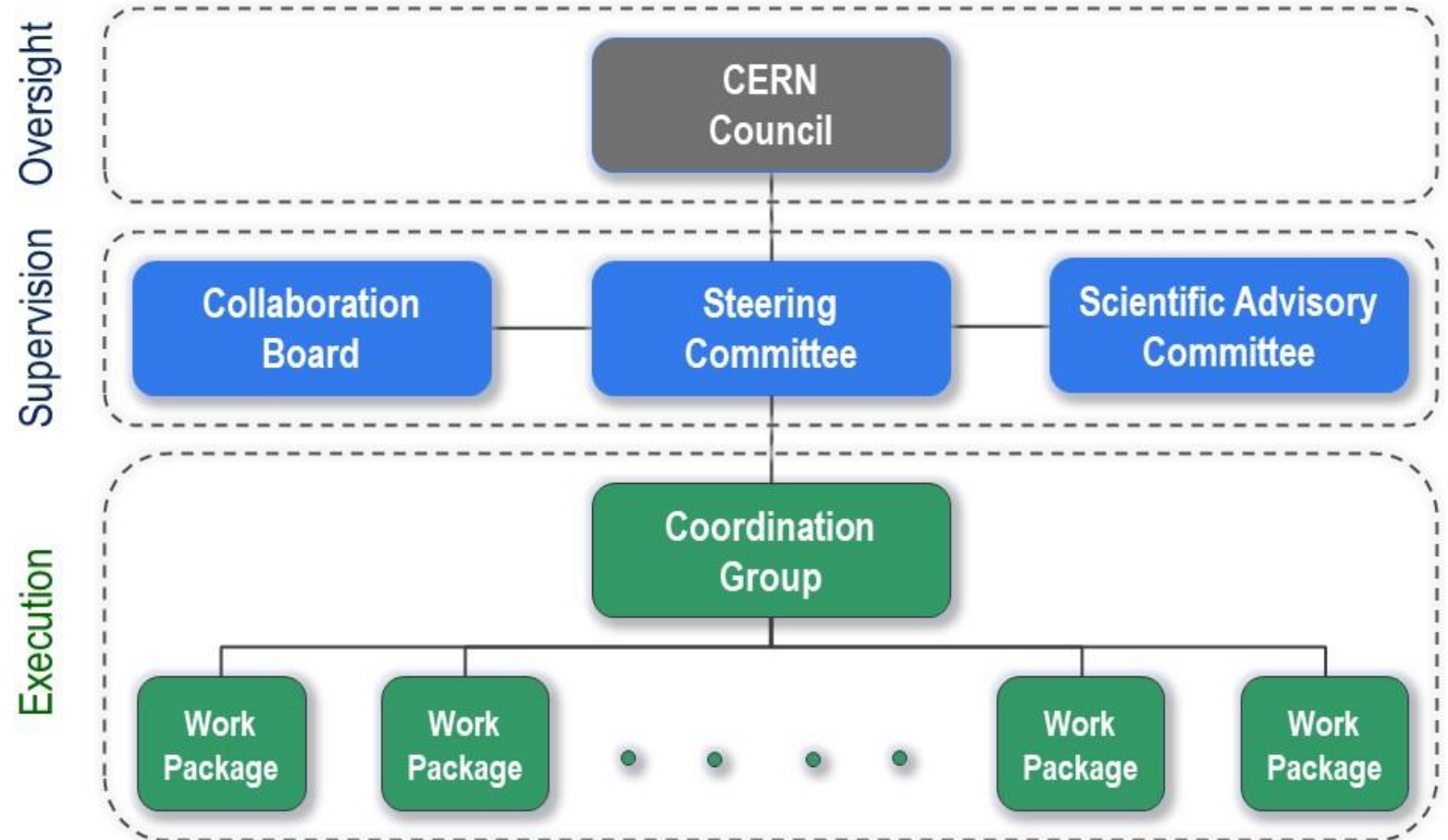

FCC Feasibility Study is organised as an international collaboration.

The FCC Feasibility Study and a possible future project will profit from CERN's decades-long experience with successful large international accelerator projects, e.g., the **LHC** and **HL-LHC**, and the associated global experiments, such as **ATLAS** and **CMS**.

Status of FCC Global Collaboration

The CERN Council reviewed the work undertaken in a fruitful meeting on 2 February 2024. It congratulated and thanked all the teams involved in the study for the excellent and significant work done so far and for the impressive progress, and looks forward to receiving the final report in 2025.

150

Institutes

32

Companies

34

Countries



FCC Feasibility Study: Aim is to increase further the collaboration, on all aspects, in particular, on Accelerator and Particle/Experiments/Detectors (PED).

FCC Week 2023
London, UK

473 participants

362 in person and
111 remote

FCC Week 2024
San Francisco, USA
10-14 June 2024

Courtesy P. Charitos



We now know much about the **Universe**, using increasingly larger and more complex machines. There remain many very **interesting and unanswered questions** in particle physics to be solved.

CERN is the right place for the next large accelerator.

The **first stage of FCC could be approved within a few years after the next European Strategy Update**, if the latter is supportive. Following **approval by the CERN Council, tunnel construction could then start in the early 2030s** and **FCC-ee physics programme could begin in the second half of the 2040s**, a few years after completion of the HL-LHC physics runs, expected by around 2040.

Long-term goal: **world-leading HEP infrastructure for 21st century** to push particle-physics **precision and energy frontiers** far beyond present limits.

We are counting on the **scientists and engineers of the future** to make the project a success for the exploration of the **fundamental laws and building blocks of the Universe**.



FUTURE
CIRCULAR
COLLIDER