

Calibration and tests of multichannel photodetection modules for the JEM-EUSO stratospheric and orbital missions



D3 PhD student: Daniil Trofimov
Supervisor: Prof. Etienne Parizot

Cosmic rays

Cosmic rays are high-energy protons and atomic nuclei that move through space at nearly the speed of light. They originate from the Sun, in our own galaxy outside of the Solar system and from distant galaxies.

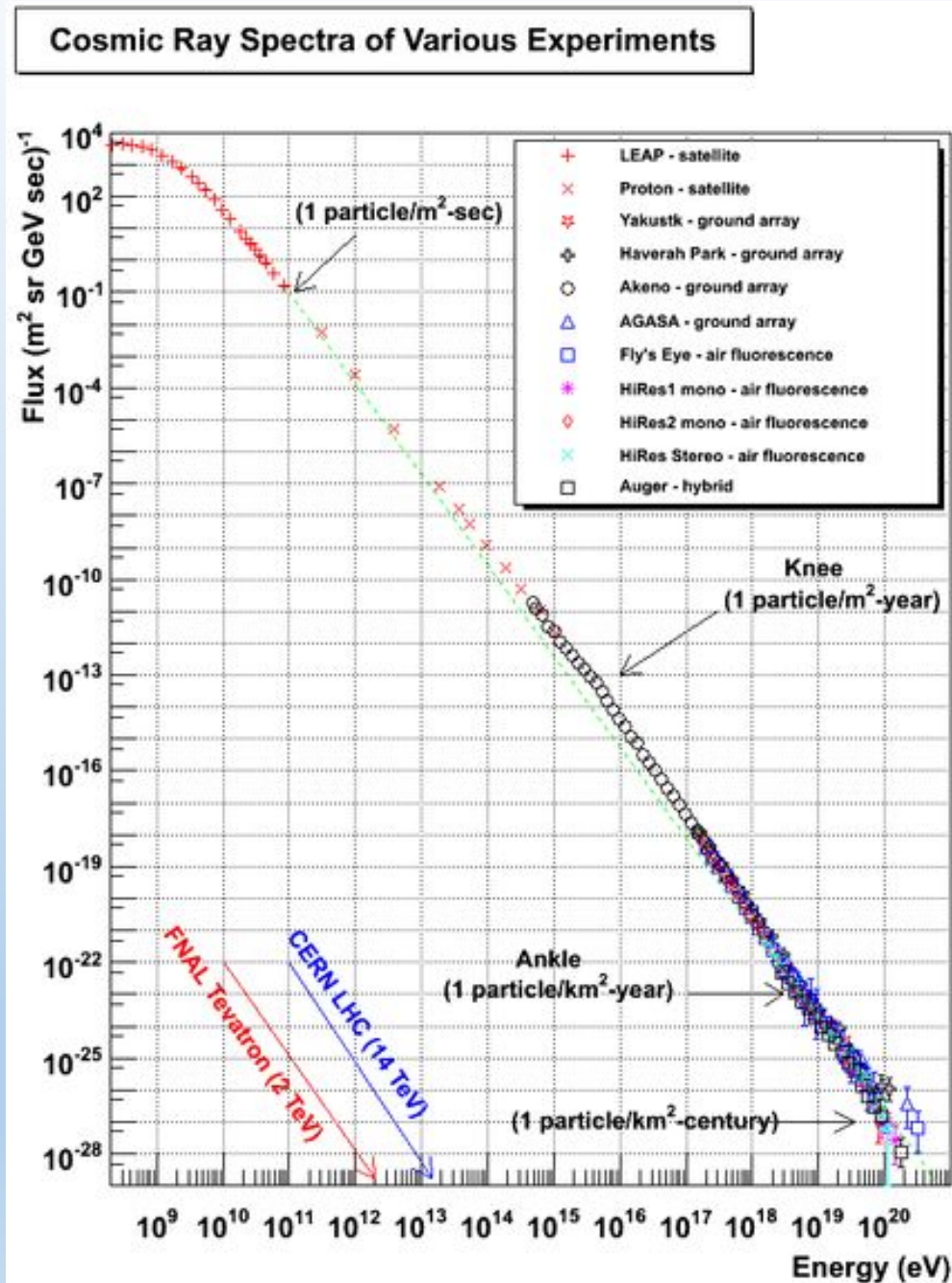

Extensive air showers (EAS)

When a primary cosmic ray with high energy enters the atmosphere, it creates an extensive air shower (EAS): a cascade of energetic particles and electromagnetic radiation produced in the atmosphere

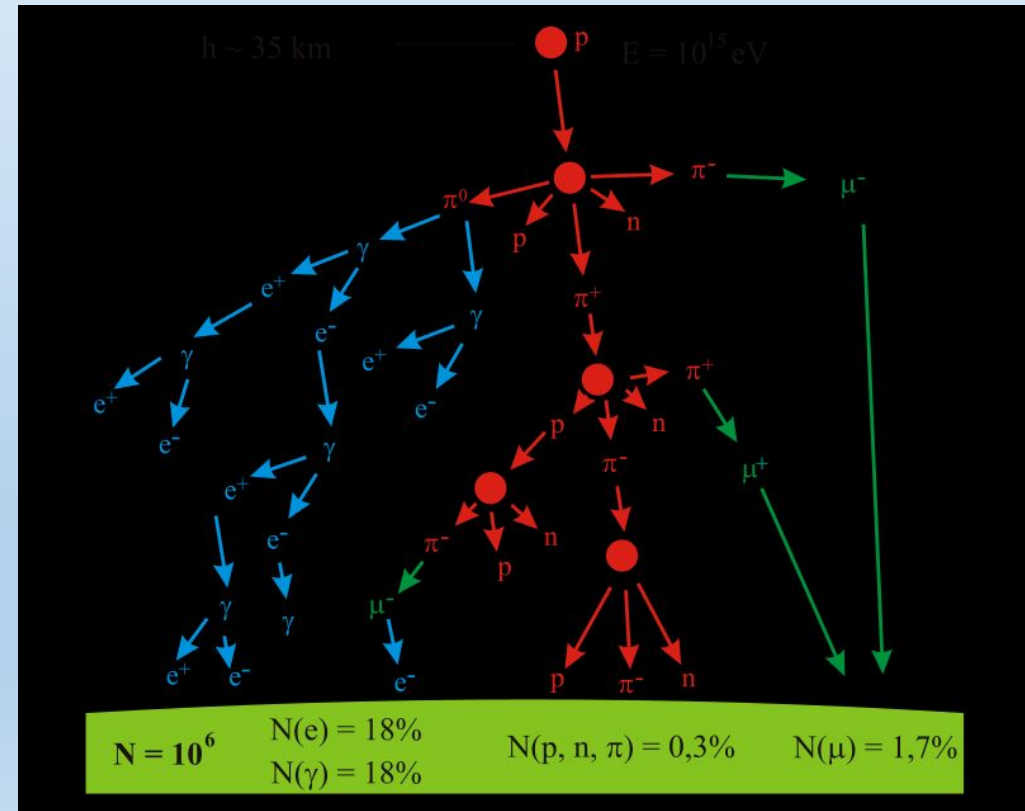
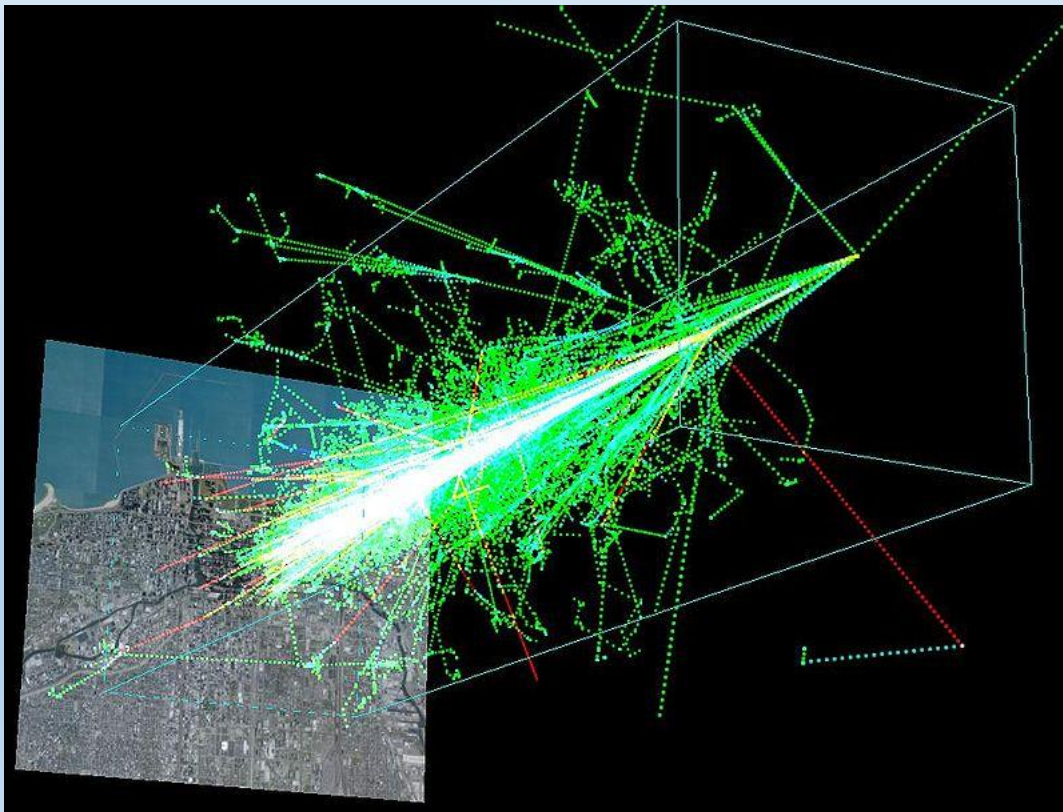

Ultra High Energy Cosmic Rays (UHECR)

Ultra High Energy Cosmic Rays are the most energetic particles in the Universe with energies up to 10^{20} eV and beyond, i.e. macroscopic energies (several tens of Joules!)

These particles are detected through the observation of extensive air showers.

The origin of UHECRs remains one of the most challenging mysteries in astrophysics

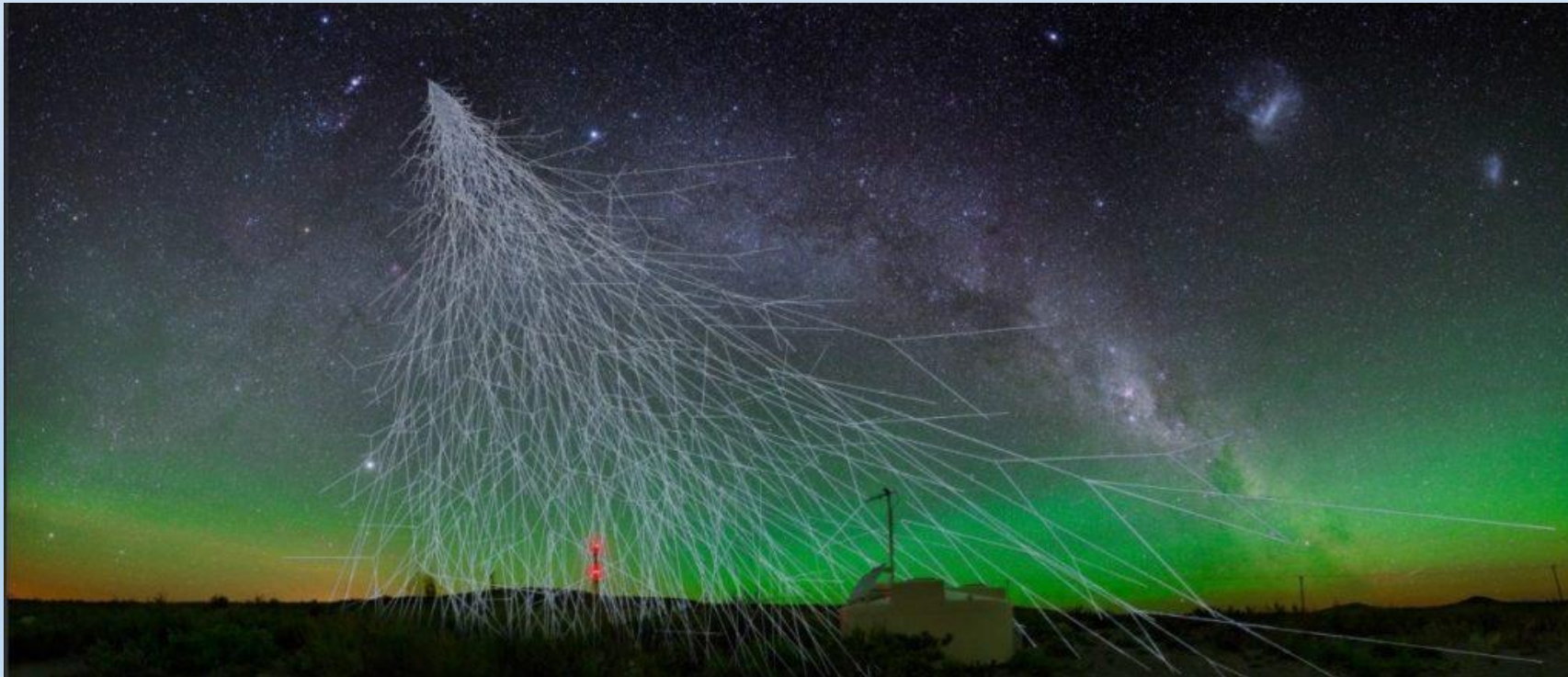

Ground-based installations

The currently operating ground-based observatories (Auger and Telescope Array) could only detect around two dozen of events with energies exceeding 10^{20} eV, with very non uniform exposure of the sky in the northern and southern hemispheres. This proved insufficient to determine their sources, composition, and acceleration mechanism.

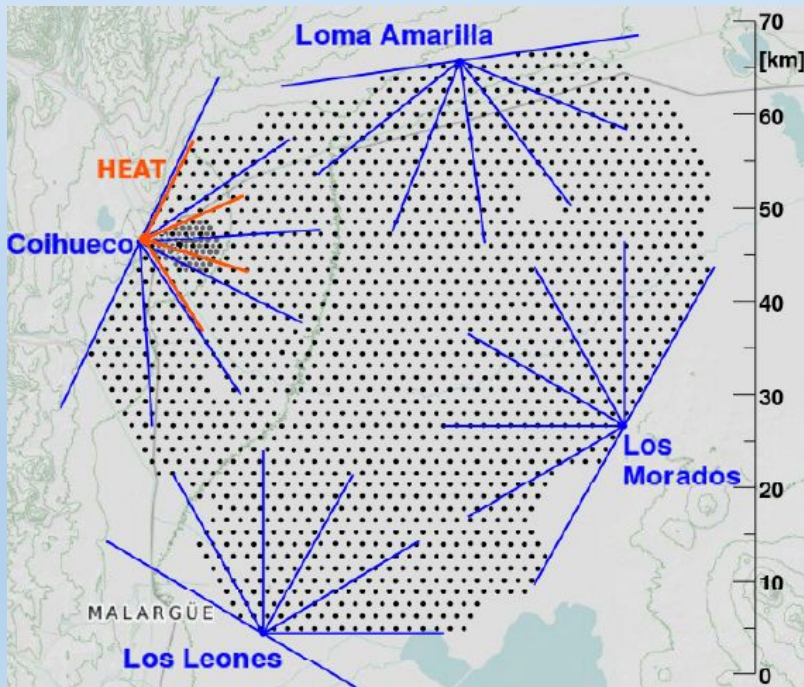

Pierre Auger Observatory map and installation unit

UHECR spectrum

Two different spectra were obtained by 2 ground-based detectors (Auger and TA).

It may be due to different systematic uncertainties or to the fact that the observed regions of the sky are different (Auger in the south and TA in the north hemisphere).

Full-sky UHECR observation with one single instrument from space-based should help disentangling this issue and give improved information about UHECR anisotropies.

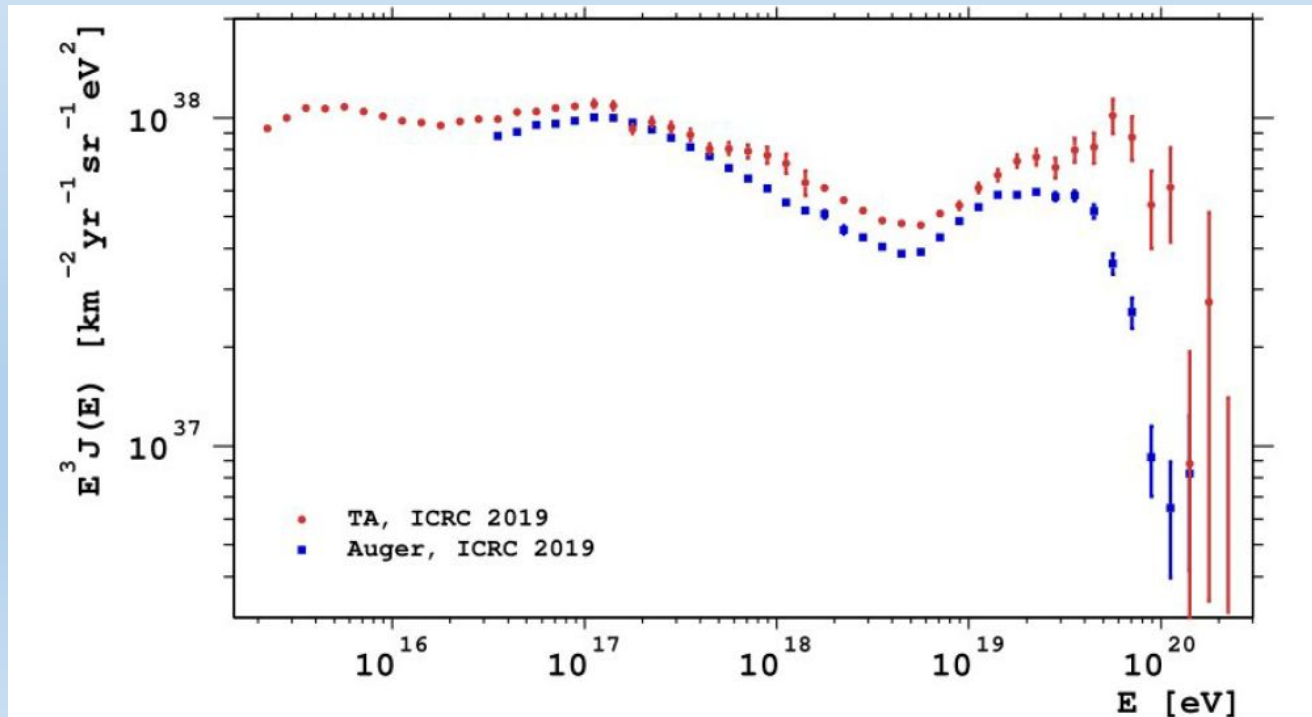

The aim of JEM-EUSO projects

JEM-EUSO (Joint Experiment Missions for Extreme Universe Space Observatory) develops the technique for the UHECR and neutrino detection by fluorescence and Cherenkov light of EAS from the Earth's orbit. The SPB (Super Pressure Balloon) experiment is a stratospheric pathfinder for K-EUSO and POEMMA orbital missions.

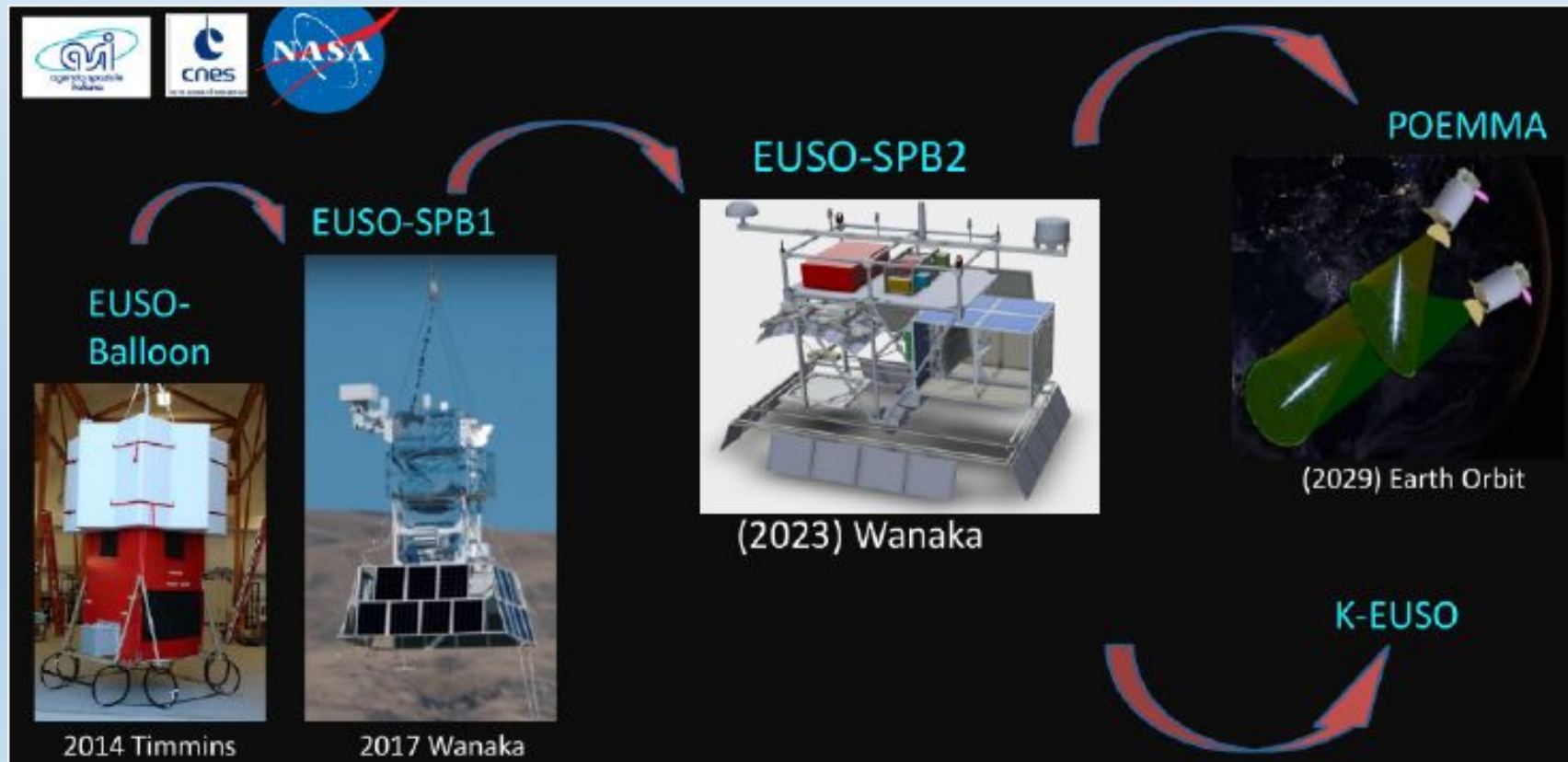

Scientific objectives of the EUSO-SPB2 experiment

- The first observations of extensive air showers (EAS) using a fluorescence telescope from suborbital space.
- Detection of the Cherenkov light of EAS induced by high-energy cosmic rays.
- Measurement of the background for the detection of neutrino-induced ascending EAS.
- Search for neutrinos as a result of transient astrophysical events (for example, during the merger of binary neutron stars).

To address these questions, the mission includes two instruments: fluorescence and Cherenkov telescopes.

EUSO-SPB2 Fluorescence Telescope

The main objective of the Fluorescence Telescope of EUSO-SPB2 is to observe the first extensive air showers via the fluorescence technique from suborbital space.

Expected number of EAS events: 0.12 ± 0.01 events/hour, or ~ 0.6 events per night

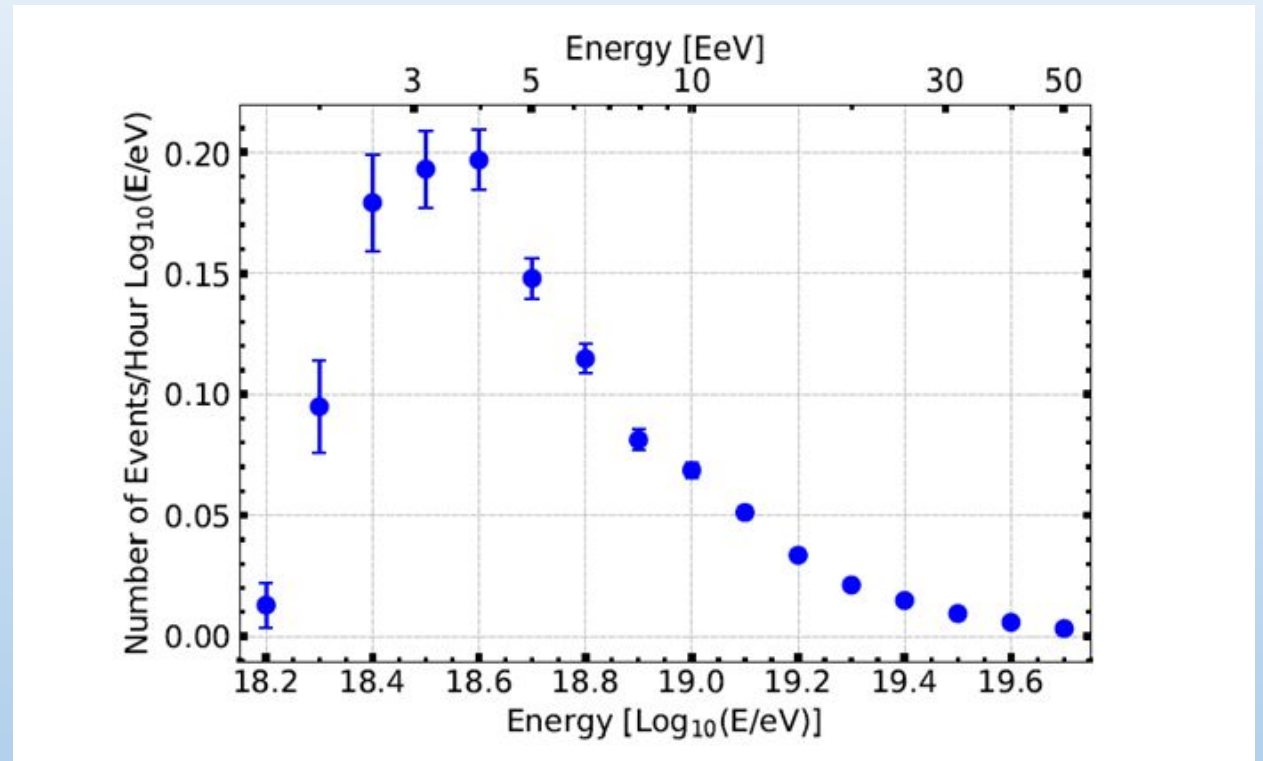

Expected number of events

EUSO-SPB2

Characteristics of the
Fluorescence telescope:

- Altitude: 33 km
- Field of view: $37.4^\circ \times 11.4^\circ$
- Aperture: 1 m
- Time resolution: $1 \mu\text{s}$
- Number of
modules/channels: 3/ 6,912

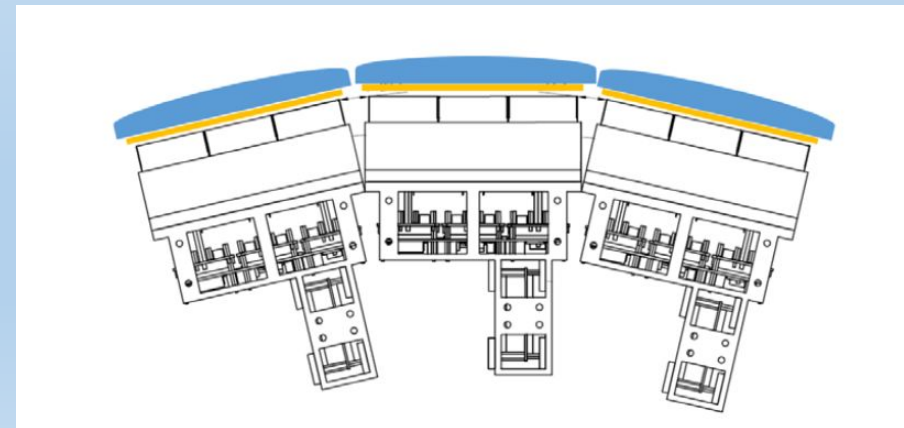
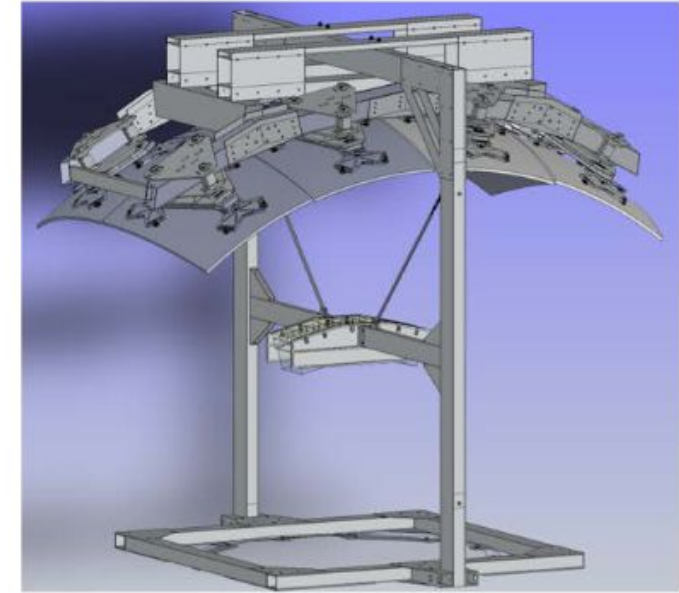
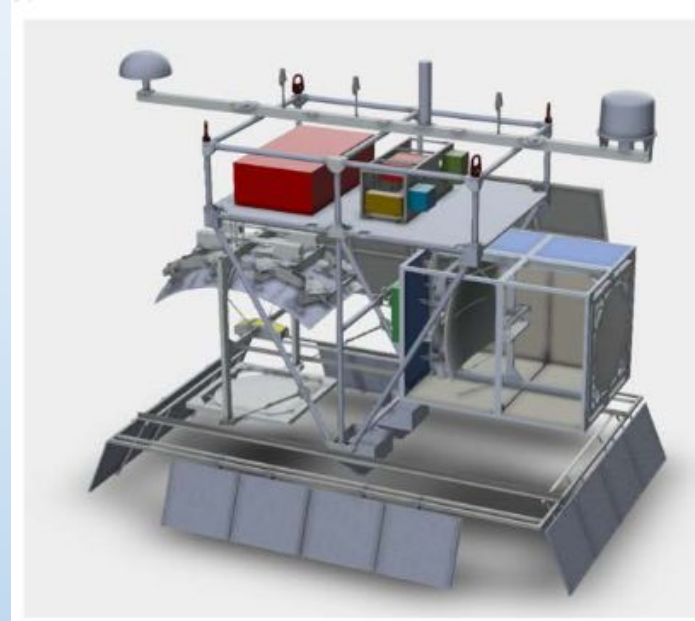

Photodetector for EUSO-SPB2 and K-EUSO

In the figure on the right: a photodetection module (PDM)

Each PDM consists of 9 elementary cells (EC-unit, bottom right figure). Each EC-unit contains a SPACIROC chip, the basis of which is a discriminator of single-photoelectronic pulses.

Each EC-unit consists of 4 HAMAMATSU R11265-103-M64 multi-anode photomultiplier tubes (MAPMTs), each has 64 channels (pixels).

Each PDM has 2304 channels of registration

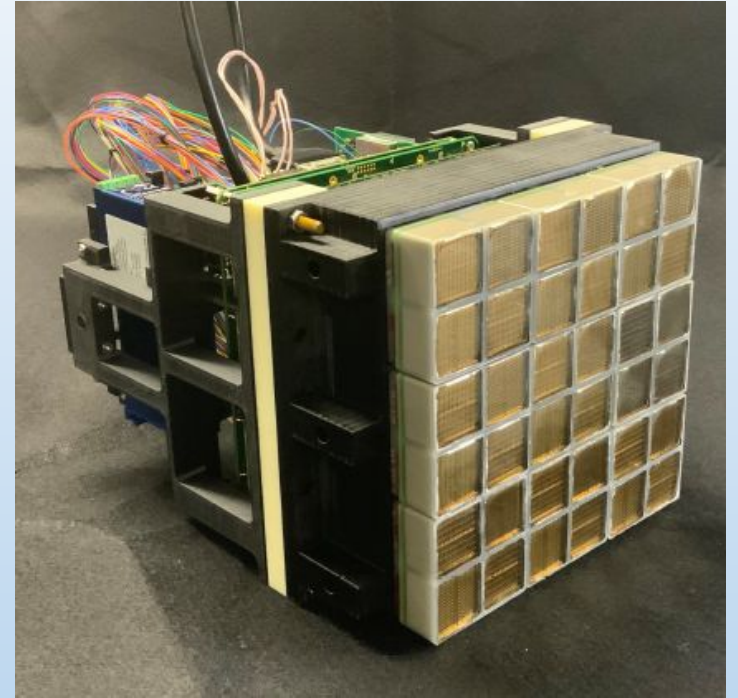

Photomultiplier Tube (PMT)

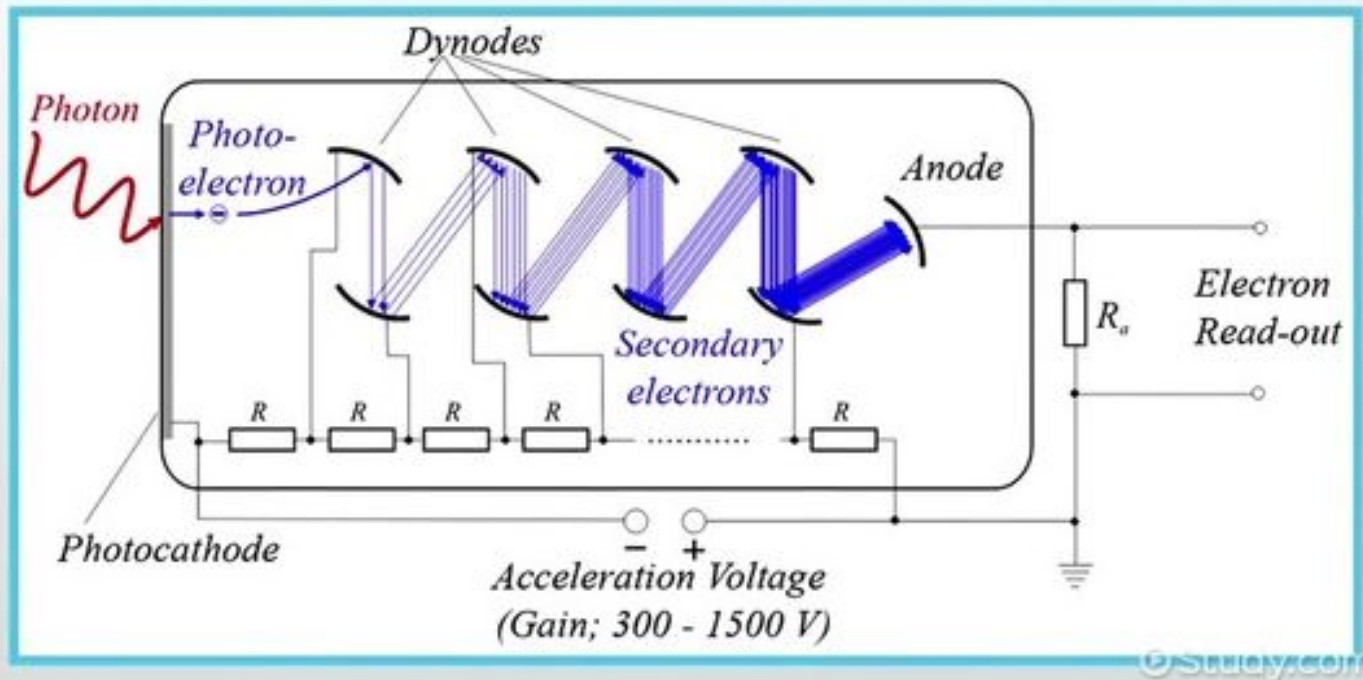

The single-channel PMT scheme of work

In the photo, the dynodes and the anode of the old single-channel PMT

Diagram of the photodetector electronics

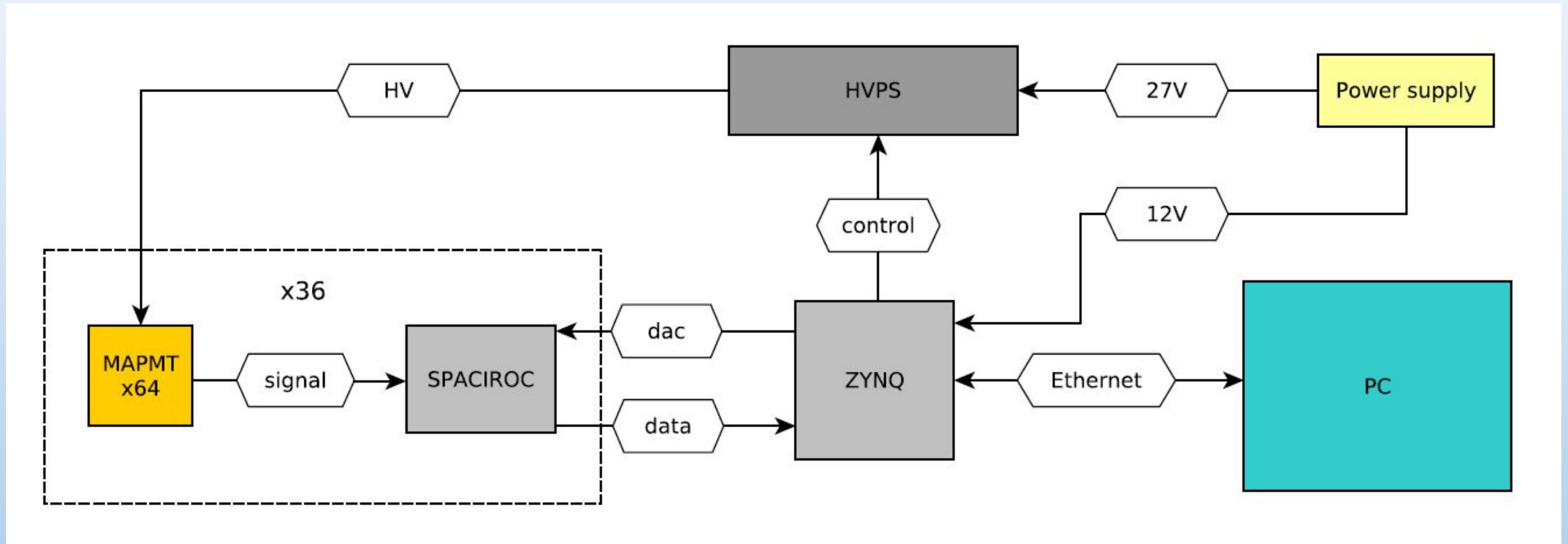

SPACIROC3 is a specialized chip designed to count photoelectronic pulses for a certain time. The basis of the chip is an amplitude discriminator, which provides the selection of single-photoelectronic pulses.

Calibration scheme of EUSO-SPB2

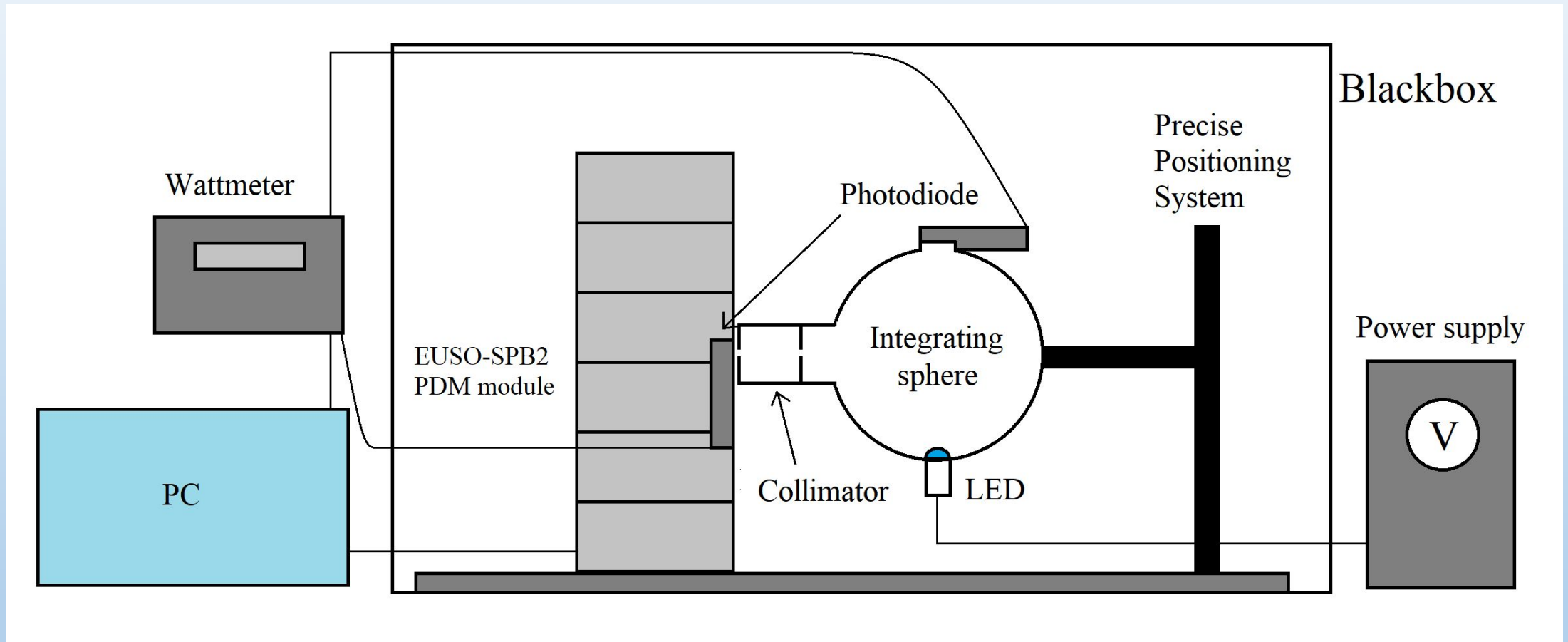

Scheme of the calibration process, with a collimator attached to the integrating sphere for single pixel illumination.

PDM Integration

Three PDMs have been integrated. On the right – uniform illumination mode

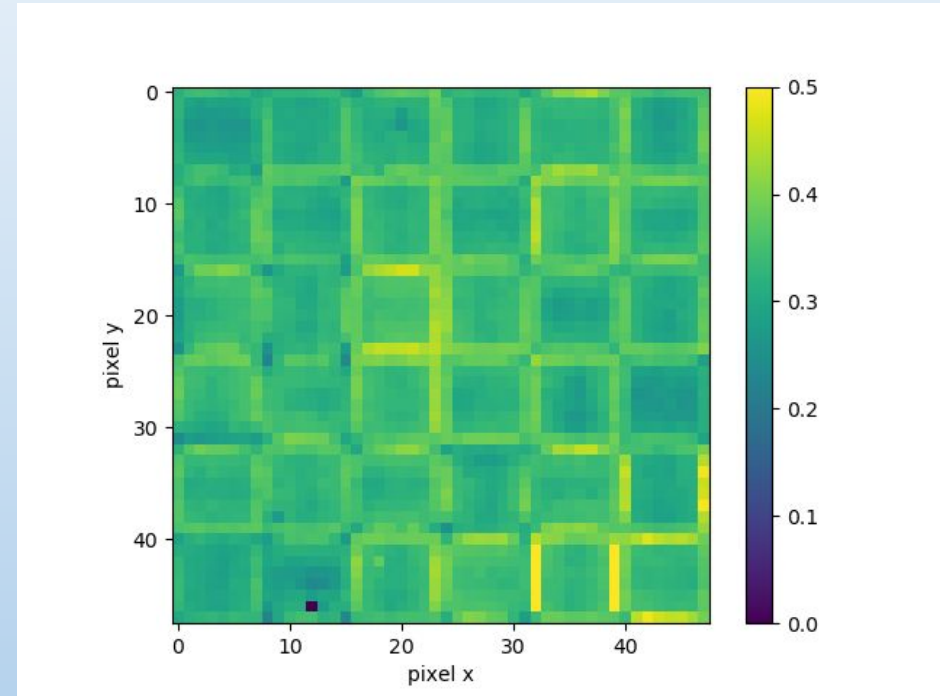

EC48	EC45	EC58
EC35	EC47	EC46
EC50(inv)	EC43	EC60

EC59	EC63	EC64
EC57	EC62	EC53
EC61	EC49	EC42

EC36	EC54	EC34
EC55	EC40	EC52
EC41	EC39	EC38

S-curve measurements

The S-curve is measured to set the optimal thresholds on each pixel and to verify their performance.

The threshold cuts off noise and counts pulses corresponding to the signal of 1 photo-electron. A 10-bit DAC allows to set the counting threshold at the level of each PMT, while a 7-bit DAC allows to shift the reference of the 10-bit DAC scale individually for each pixel.

In our case, we use a single 10-bit DAC threshold at 800, after adjusting all pedestals with the use of the 7-bit DAC pixel by pixel.

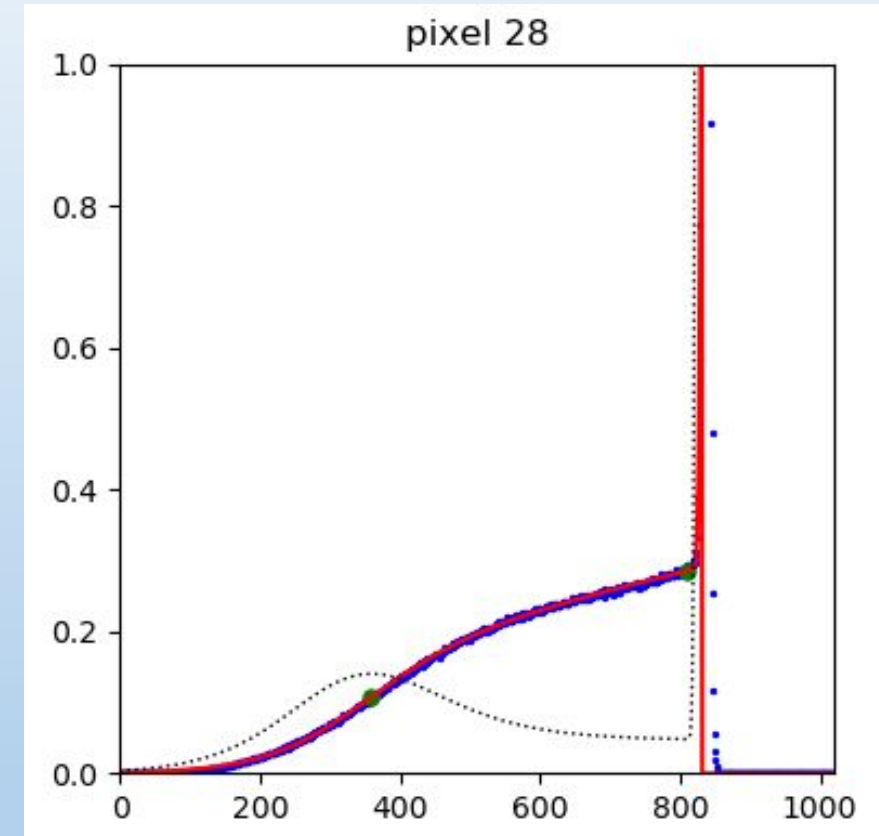

Alignment of s-curves after individual 7-bit DAC setting

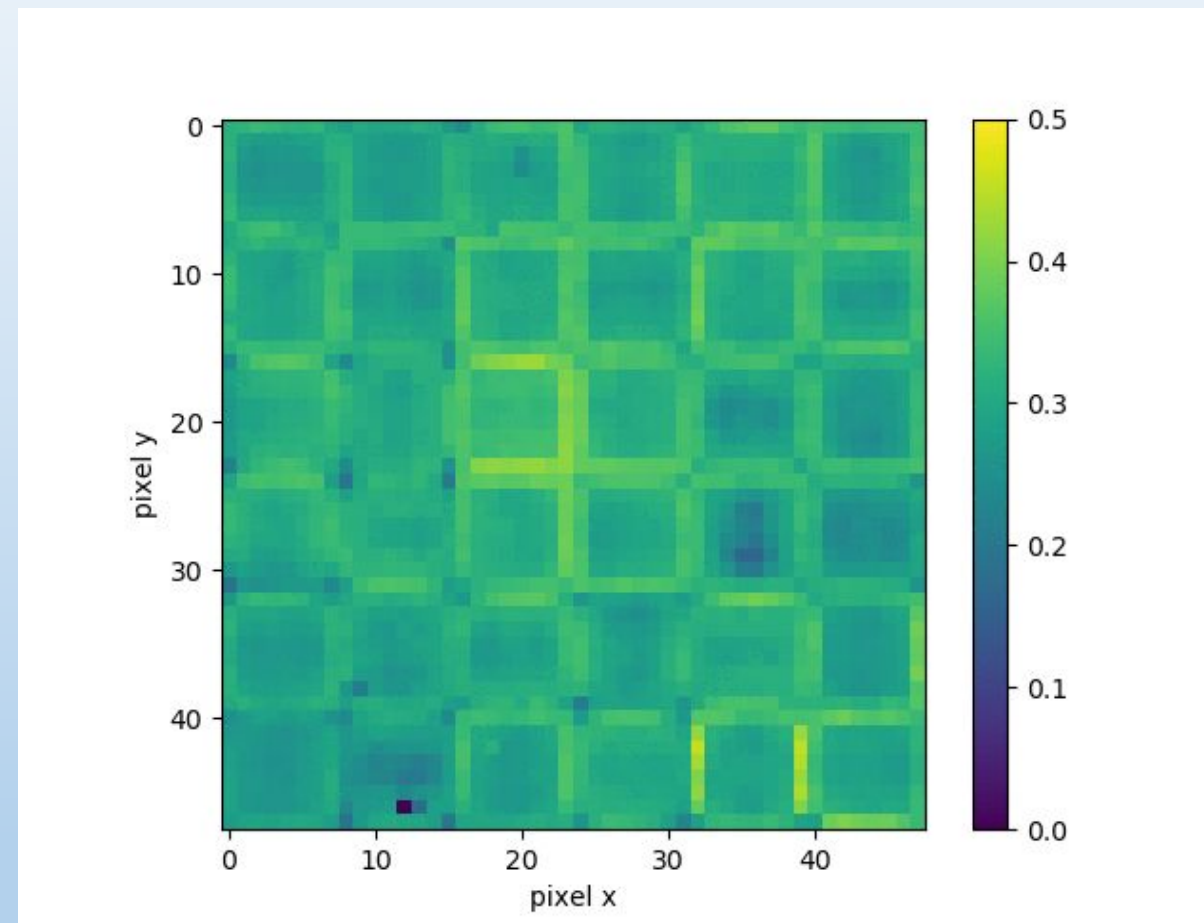
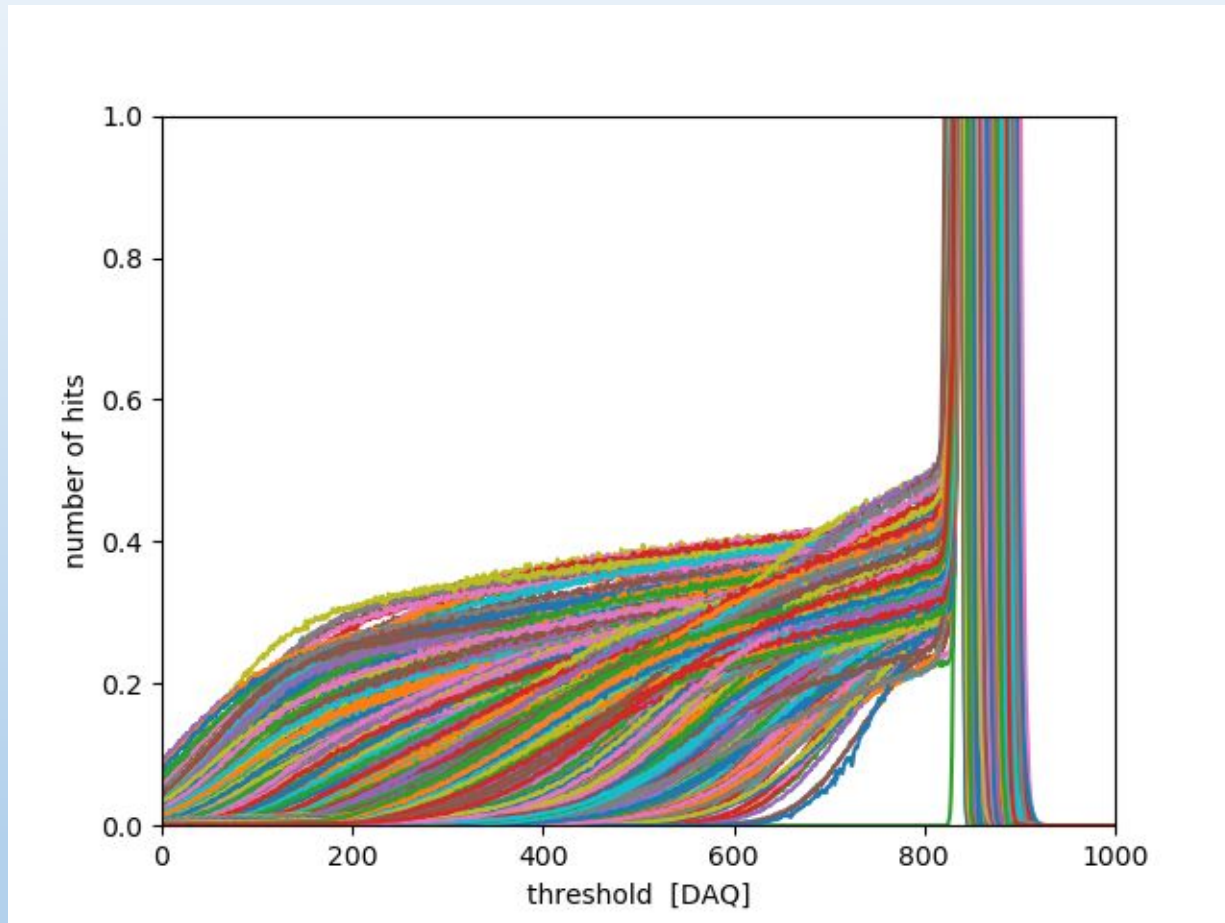

After setting the individual thresholds, you can see that in DAC10 mode, the pedestals of all pixels begin almost simultaneously

Example of a full PDM scan

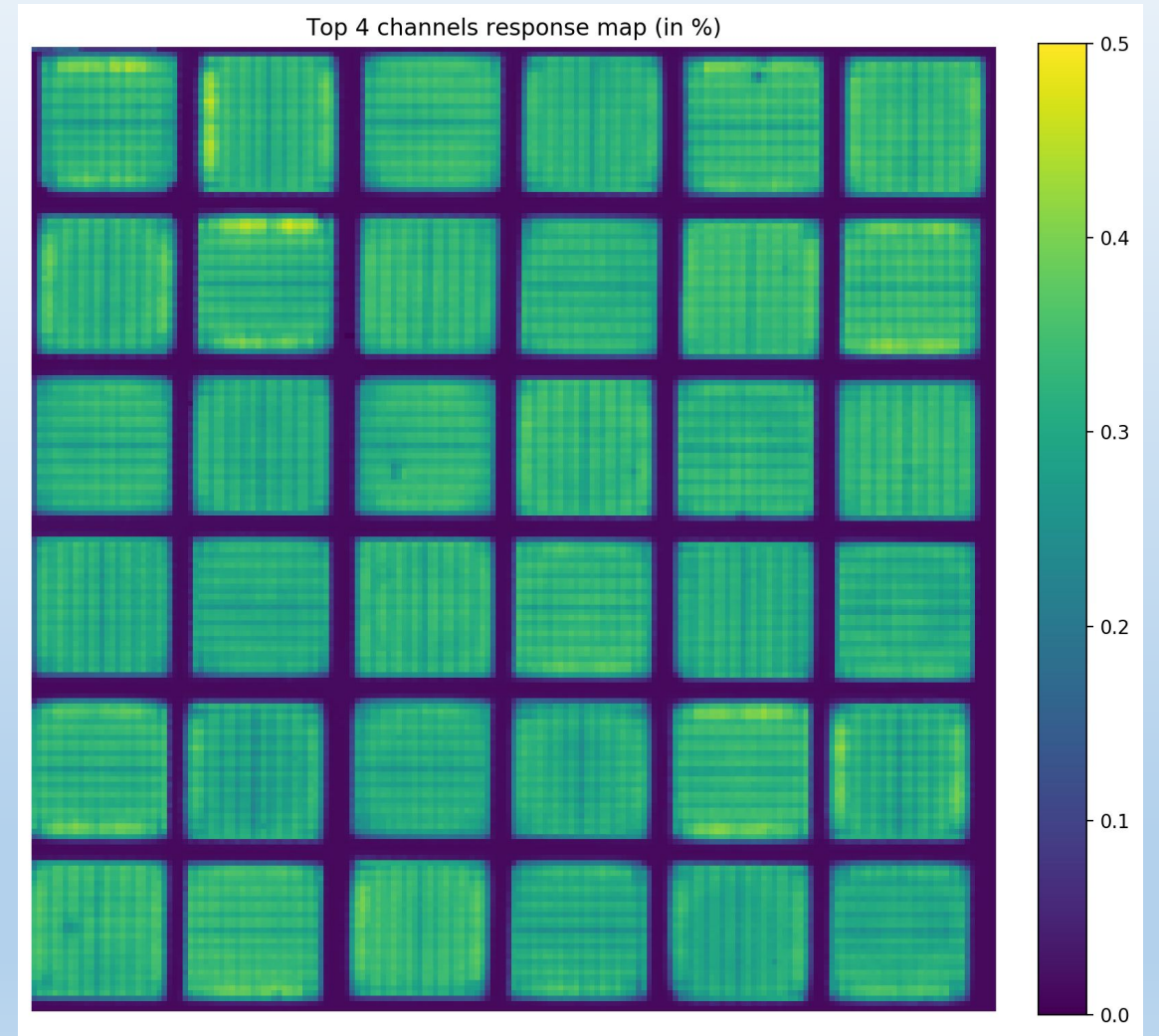
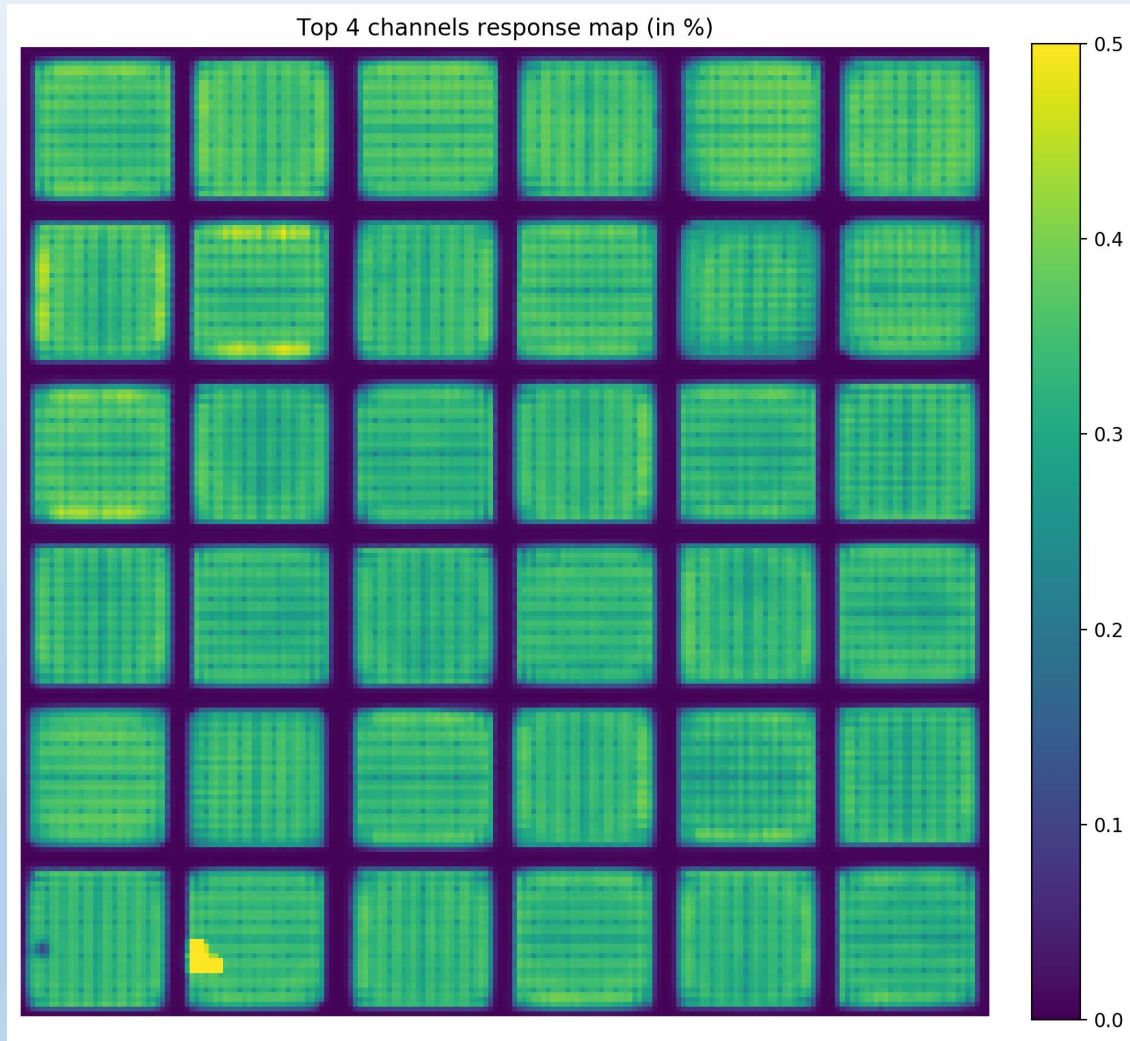

PDM1 and PDM3, wavelength 375nm, resolution is 200x200 pixels

Partial PDM Scan

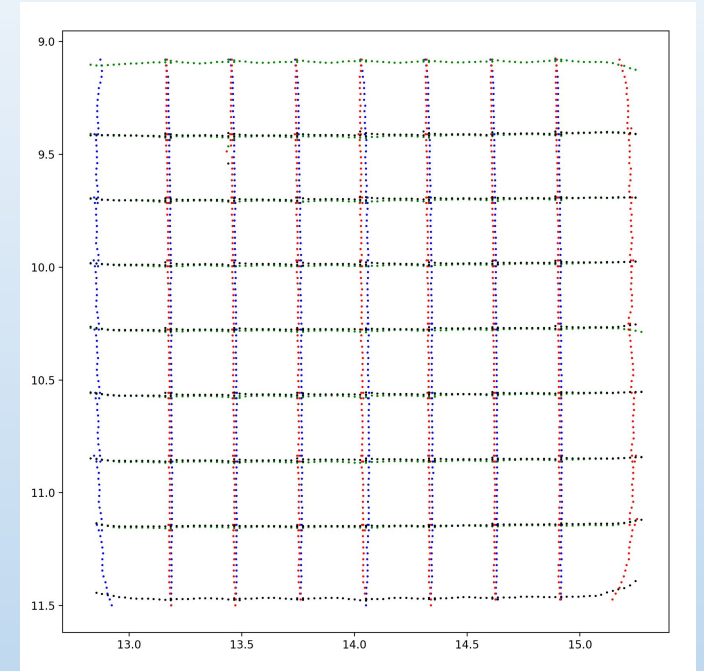
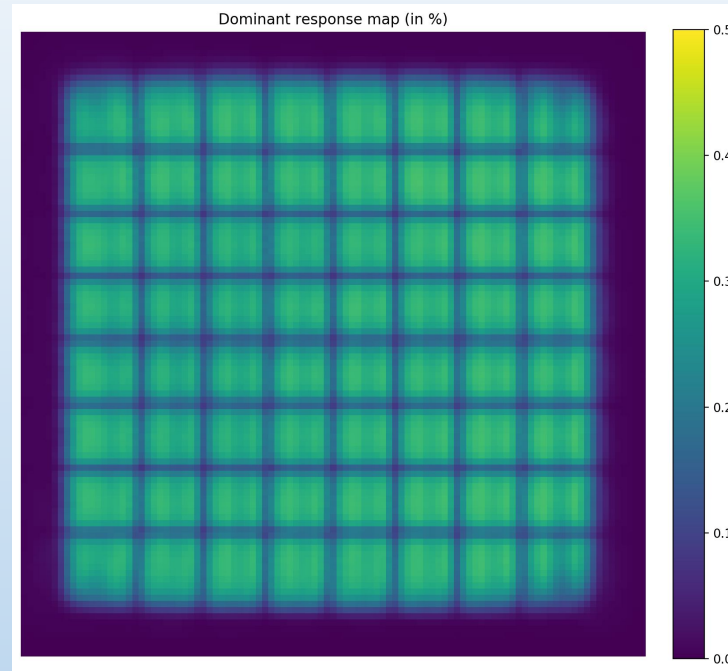
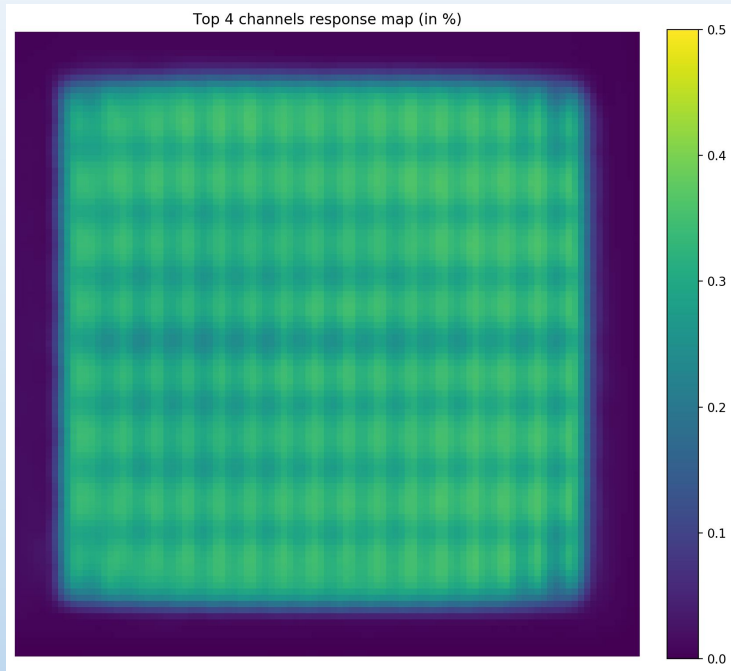

Left: top-4 channel response map (for each position, we sum the photon count of the 4 brightest pixels to derive the total detection efficiency at that position). Center: dominant response map (photon count rate of the brightest pixel only). Right: borders of the MAPMT. The last figure reveals that border pixels are larger than central ones – causing “border effects” in full illumination mode (PMT22 of PDM2, $\lambda = 405\text{nm}$, 100 x 100 resolution)

Compare pixel profiles when scanning

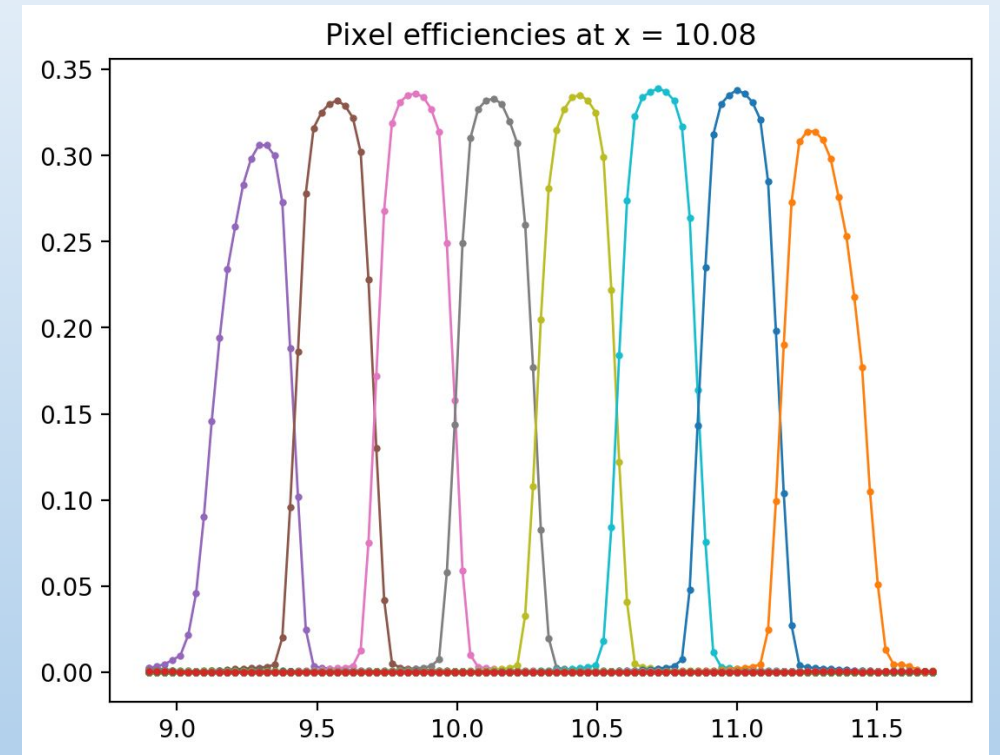
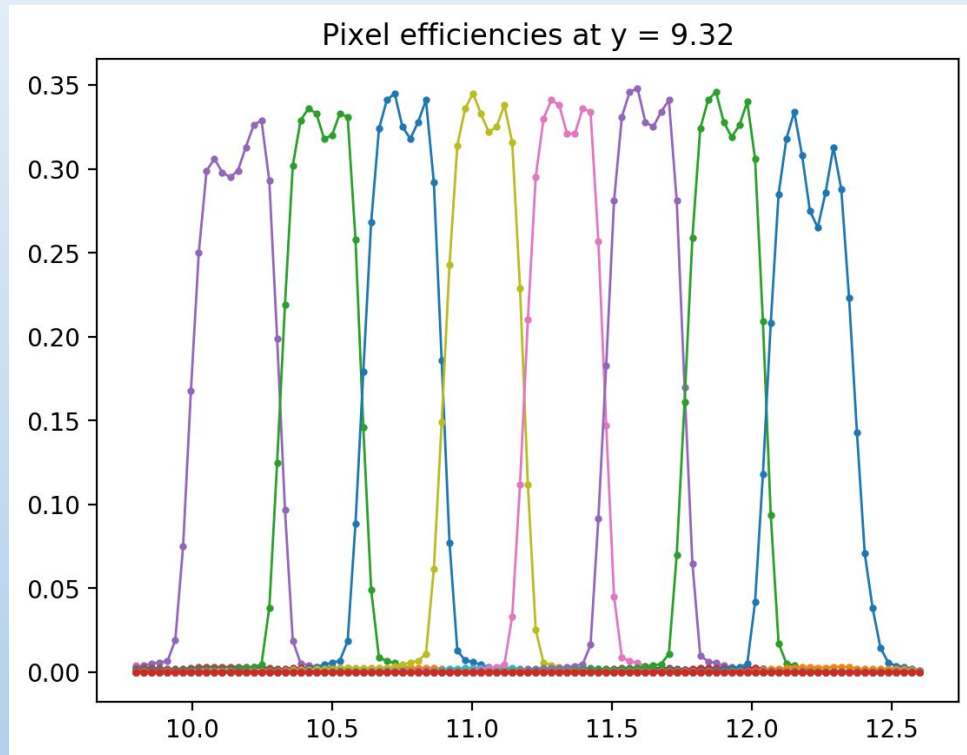

The structure of the pixels depends on the direction of scanning (vertically or horizontally)
In the center, the efficiency is less!
PMT22 of PDM2, wavelength $\lambda = 405\text{nm}$

Study of the effect of overlapping impulses (Pile-up)

For high light intensity, “pile-up” occurs when the time interval between consecutive photoelectrons is smaller than the time resolution of the ASIC (a few ns). The number of counts thus saturates and eventually decreases as the photon rate increases (more and more photons being missed). The expected counting rate is $\varepsilon N \times \exp(-\varepsilon N \delta t)$, where N is the incoming photon rate, ε is the detection efficiency and δt is the double pulse resolution (dead time).

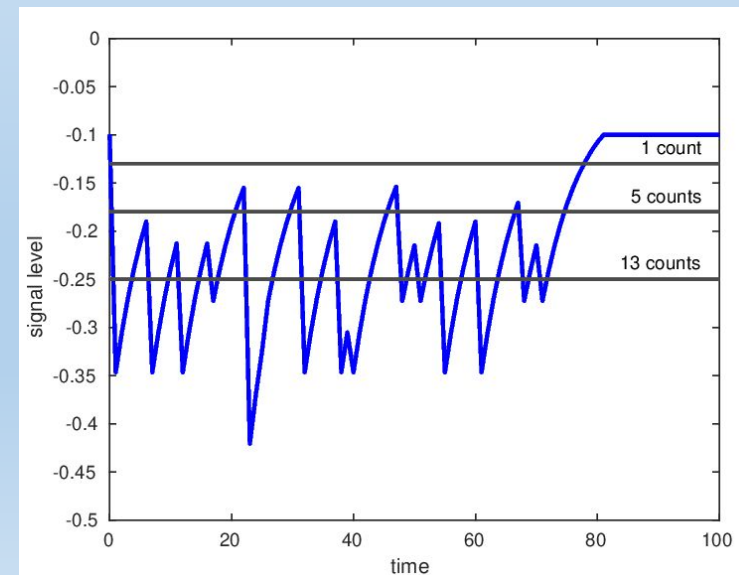
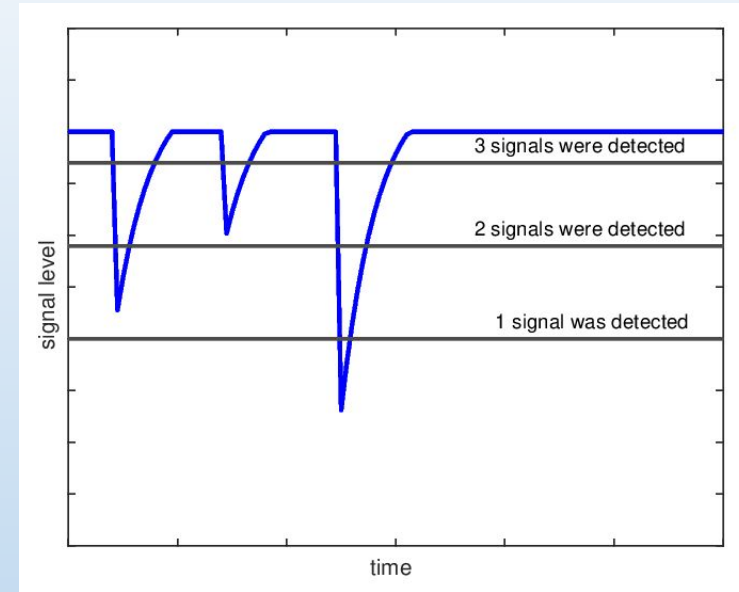

Pile-up effect in the photodetector EUSO-SPB2

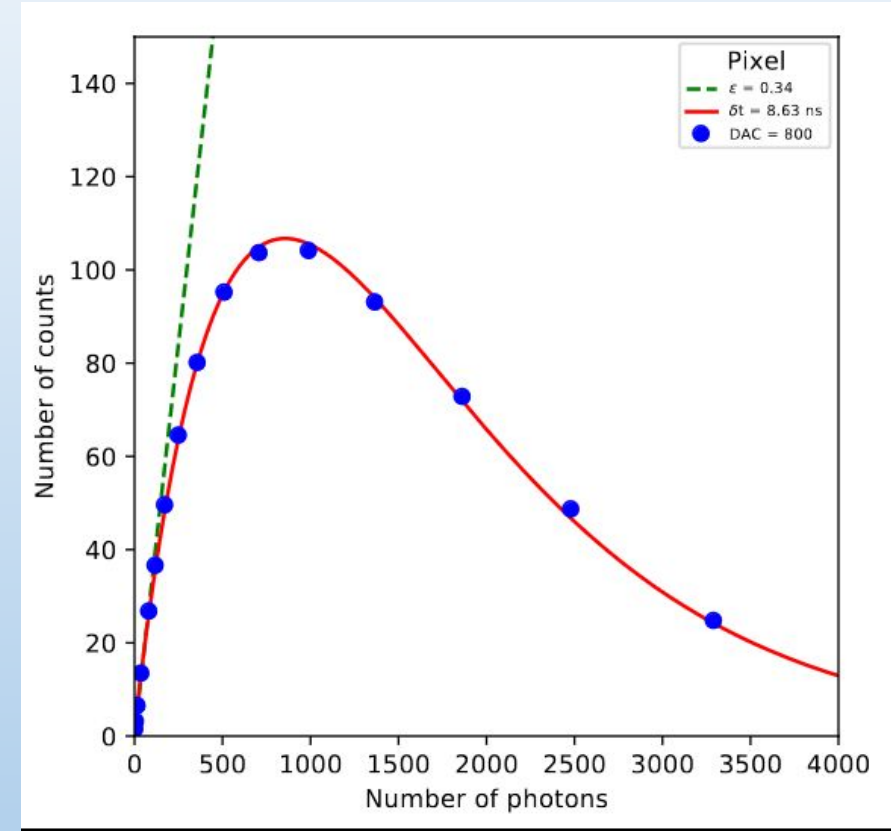
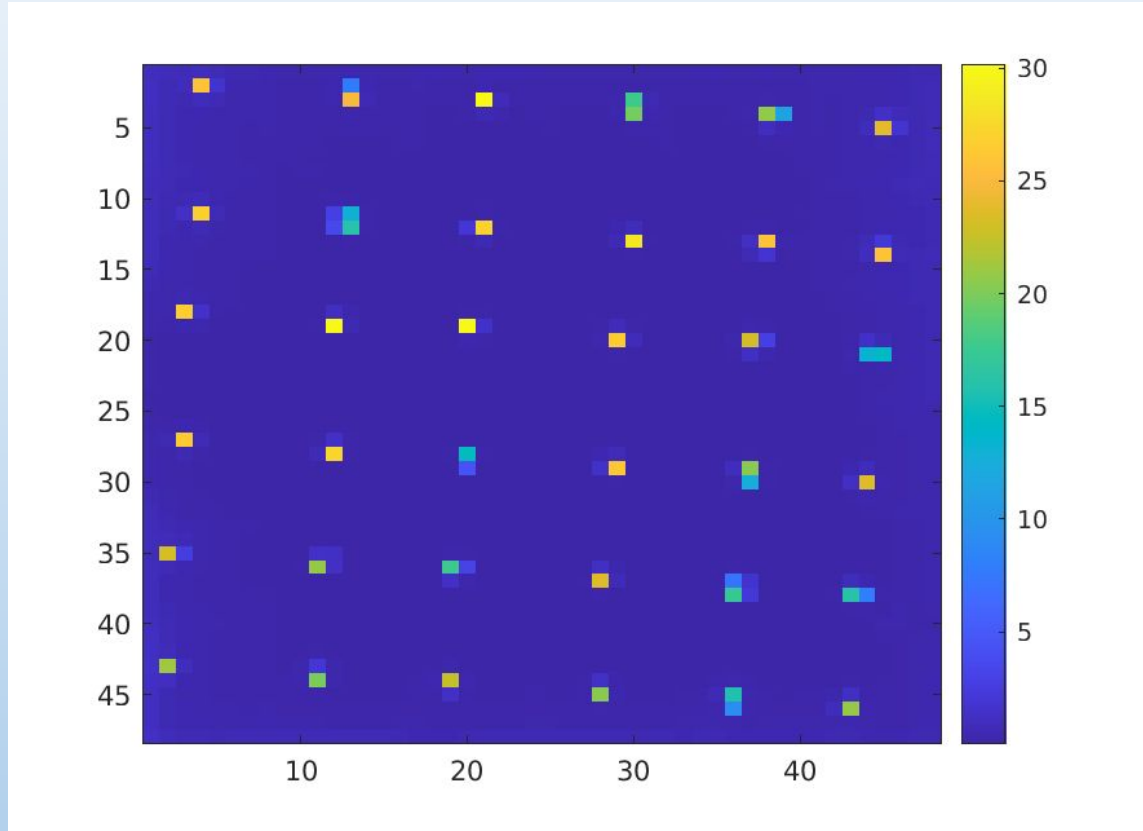

Time resolutions has been calculated for all 108 MAPMTs a fluorescent telescope EUSO-SPB2. The measurements could not be carried out in full light mode due to the reduction of high voltage in strong light conditions.

Pile-up effect in the photodetector EUSO-SPB2

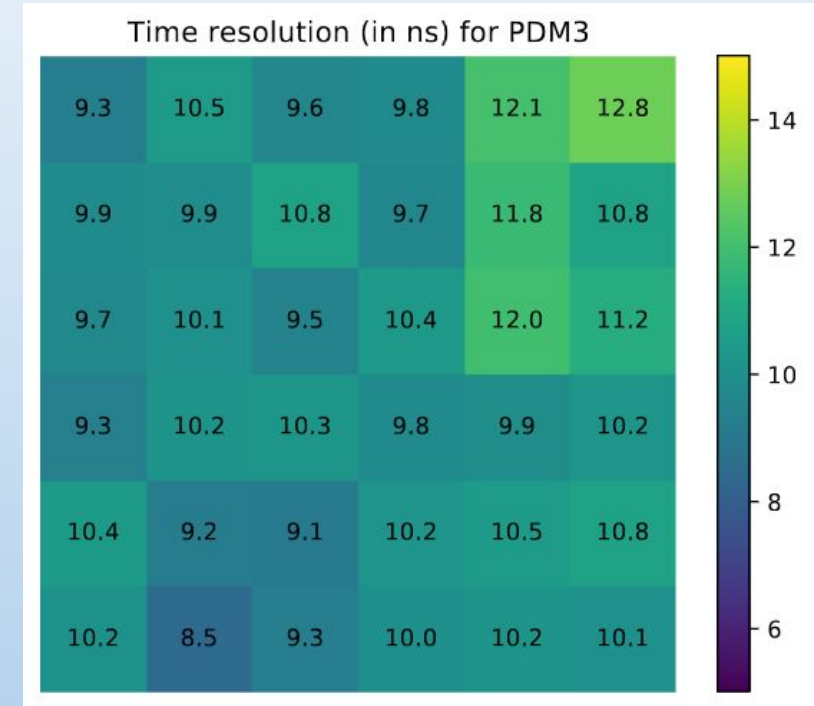
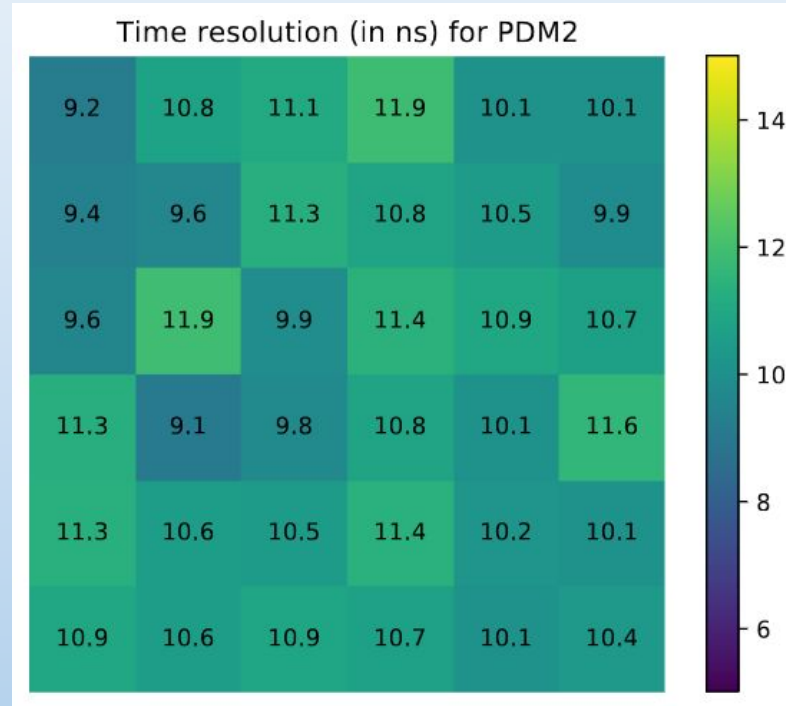
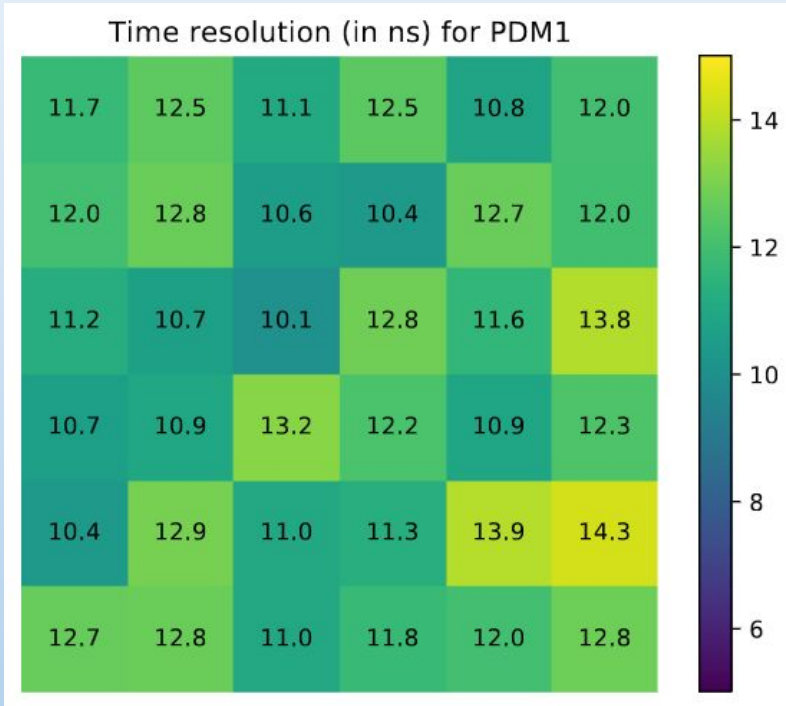

3 figures with the time resolution for each MAPMT of all PDMs

Time resolution dependences

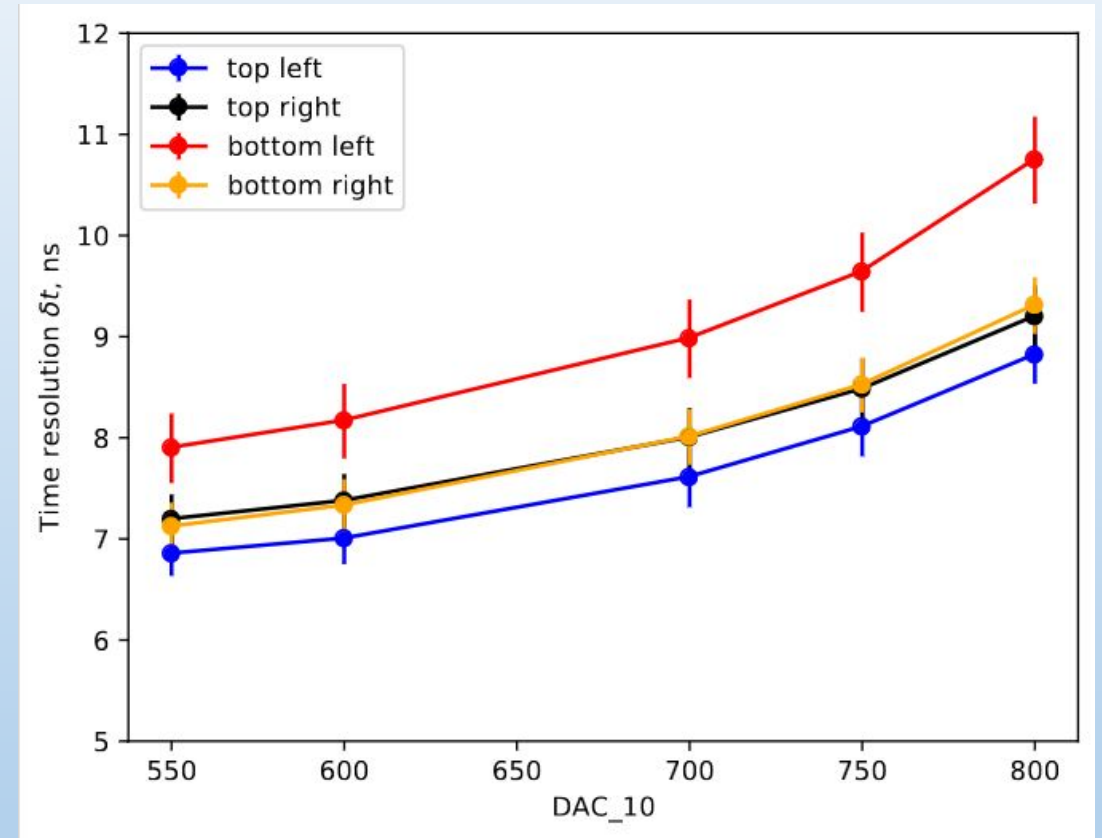
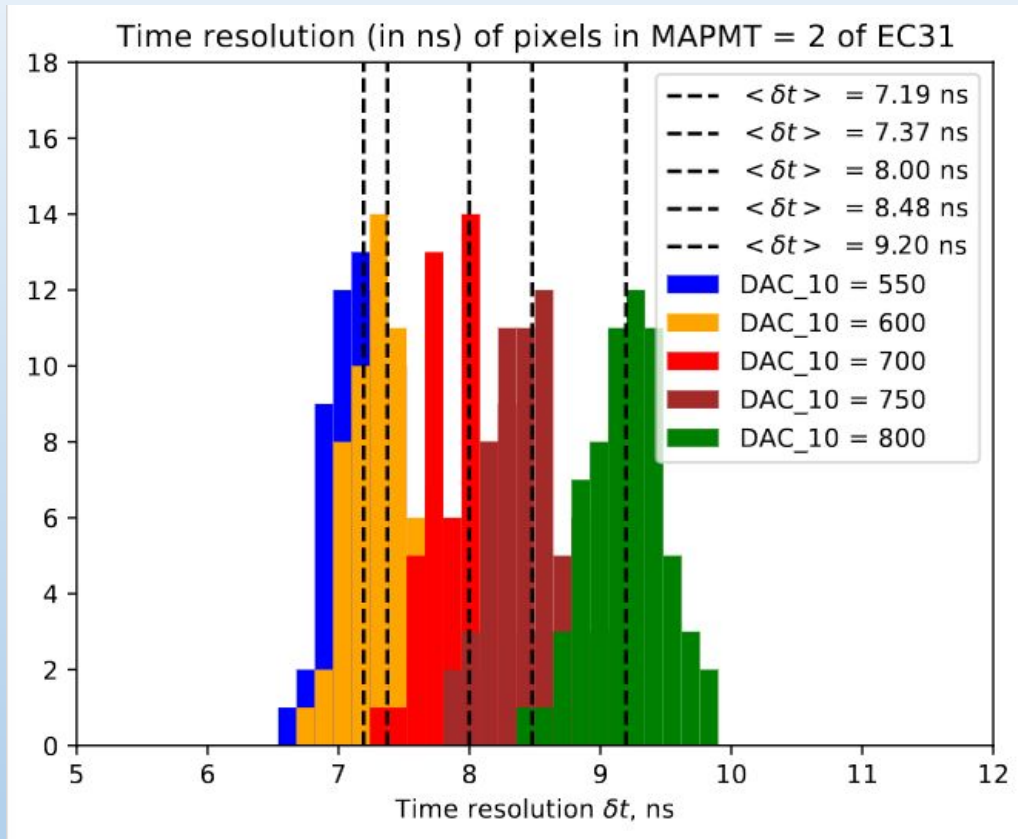

Left figure: time resolution diagram for all pixels of one MAPMT. Right: the dependence of mean time resolution for MAPMT on thresholds

KI mode in EUSO-SPB2 FT

When the light level is high, the device uses KI mode.

There are 8 such channels for each MAPMT. Each KI channel performs summation of the charge from the 8 anodes of the corresponding pixels, which is then encoded on 6 bits (i.e. with values from 0 to 63).

The response of KI channels is not linear to the photon flux (due to the internal characteristics of the ASIC, as well as the power supply limitations inherent in a low-consumption system)

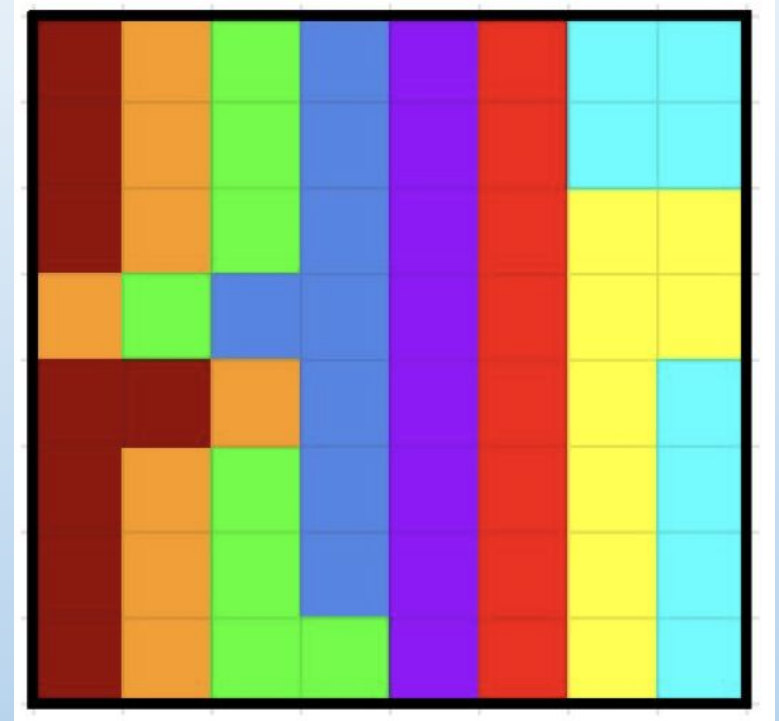

Map of matching photoelectron detection channels (PE) and integrated mode channels KI

KI mode in EUSO-SPB2 FT

KI mode is used for collecting data in high-light conditions, and for interpreting photoelectron detection data.

At high illumination, the effect of superimposing pulses occurs in the photoelectron detection mode (starting from 40 photons per microsecond / pixel). Because of this effect, some of the photoelectrons are not detected, because there is a dependence on the dead time of the discriminator.

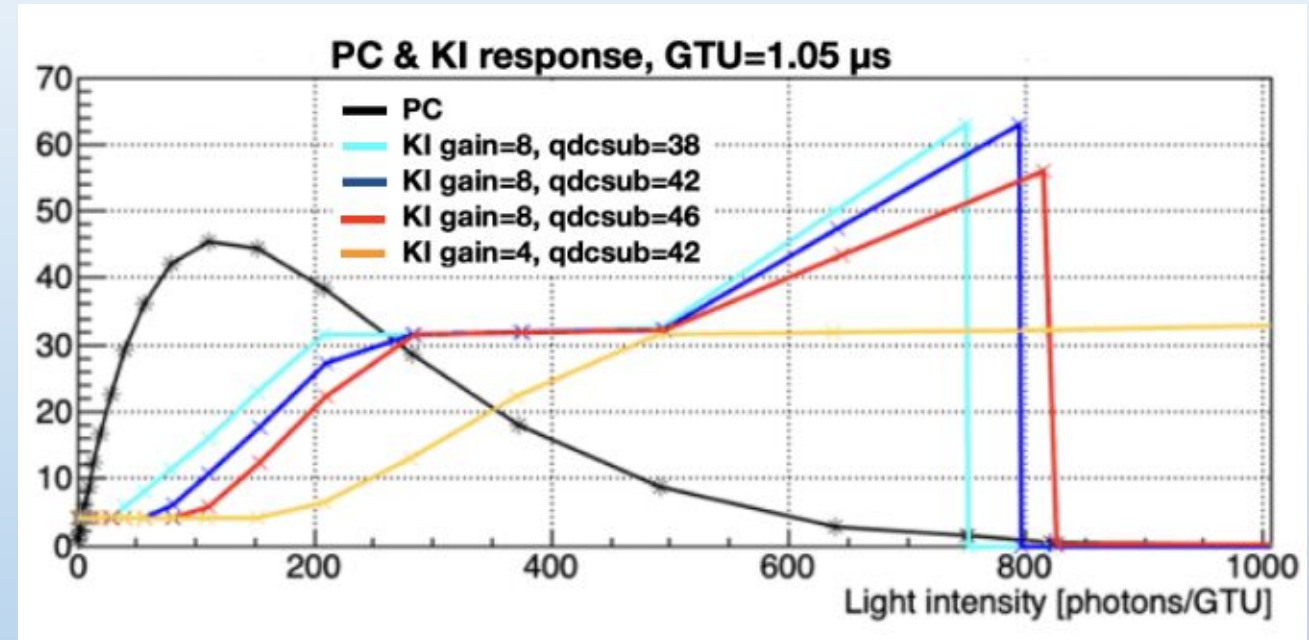

Figure 1 shows the curves for the photoelectron detection mode (Photon counting) and the mode KI with different characteristics gain (gain) and qdcsub (subtraction current). The measurements were carried out when one channel of the photodetector was illuminated using a collimator, the luminous flux intensity was from 1 to 1000 photons per channel per time. GTU (1.05 μ s). Data was taken simultaneously from both channels

Launch EUSO-SPB2



The EUSO-SPB2 was launched in New Zealand on May 13, 2023 and it worked until May 14. The telescope made measurements at an altitude of 33 km during 2 nights of operation. The equipment recorded more than 120,000 “events”, mostly related to background fluctuations.

Conclusions

EUSO-SPB2 photodetector modules have been calibrated with high precision in different modes. Detailed information about the size, efficiency and time resolution of each pixel will allow us to analyse and reconstruct the events detected during the mission. The methods of calibration will be used in future JEM-EUSO projects such as the balloon EUSO-SPB3/PBR and orbital K-EUSO and POEMMA missions.

EUSO-SPB3/PBR will be launched in 2027 with 4 photodetection modules (PDMs) and will detect the first EAS, in a flight of 100 days.

The first observations of EAS via the fluorescence technique from suborbital space will confirm this method and open the way to orbital projects K-EUSO and POEMMA. The fluorescence detection from space will increase statistics significantly and reveal the mystery of UHECR.

Thank you for your attention