



(Un)conventional mesons between 1-2 GeV and the lightest hybrid nonet

Francesco Giacosa

UJK Kielce (Poland) & Goethe U Frankfurt (Germany)

in collaboration with:

S. Jafarzade, A. Vereijken, E. Trotti, A. Koenigstein,
M. Piotrowska, V. Shastry
R. Pisarski, C. Fischer

STRONG-2020 Annual Meeting (2022 edition)



17-19/10/2022, Orsay/Paris, France

Outline



Symmetries of QCD

Conventional and unconventional mesons

From $J=3$ downwards

$J=3$: a well-established nonet

$J=2$: from ideal tensor to unknown axial-tensor mesons

$J=2$: pseudotensor mesons: an open question about them

$J=1$: excited vector mesons: an open question

$J=1$: toward a nonet of hybrid states?

($J=0$: A new entry: the glueballonium)

Conclusions

Symmetries of QCD

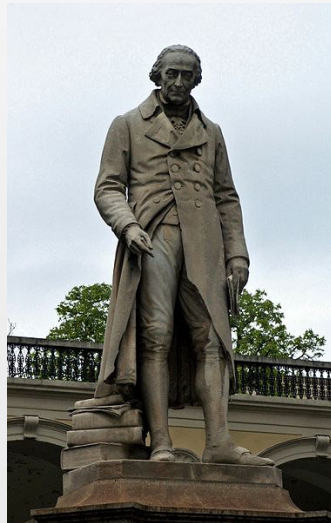

Born Giuseppe Lodovico Lagrangia
25 January 1736
Turin

Died 10 April 1813 (aged 77)
Paris

The QCD Lagrangian

Quark: u,d,s and c,b,t R, G, B

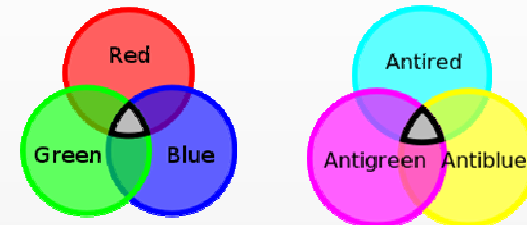

$$q_i = \begin{pmatrix} q_i^R \\ q_i^G \\ q_i^B \end{pmatrix}; \quad i = u, d, s, \dots$$

8 type of gluons (RG, BG, ...)

$$A_\mu^a; \quad a = 1, \dots, 8$$

$$\mathcal{L}_{QCD} = \sum_{i=1}^{N_f} \bar{q}_i (i\gamma^\mu D_\mu - m_i) q_i - \frac{1}{4} G_{\mu\nu}^a G^{a,\mu\nu}$$

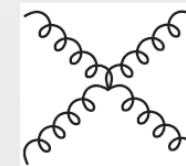
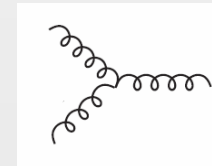
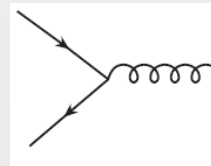

Confinement: quarks never 'seen' directly. How they might look like 😊



Picture by Pawel Piotrowski

Trace anomaly: the emergence of a dimension

Chiral limit: $m_f = 0$

$x^\mu \rightarrow x'^\mu = \lambda^{-1} x^\mu$ is a classical symmetry broken by quantum fluctuations (trace anomaly)

Dimensional transmutation

$$\Lambda_{YM} \approx 250 \text{ MeV}$$

$$\alpha_s(\mu = Q) = \frac{g^2(Q)}{4\pi}$$

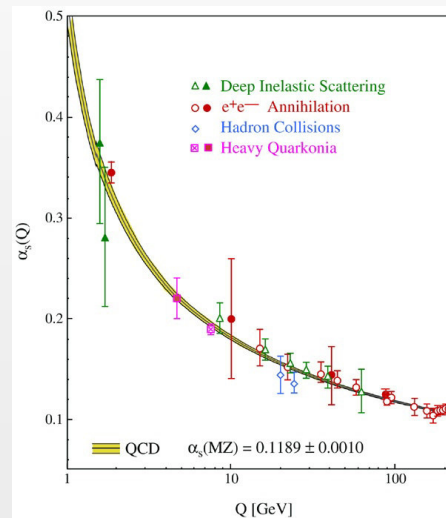

Effective gluon mass: $m_{gluon} = 0 \rightarrow m_{gluon}^* \approx 500 - 800 \text{ MeV}$

Gluon condensate: $\langle G_{\mu\nu}^a G^{a,\mu\nu} \rangle \neq 0$

Flavor symmetry

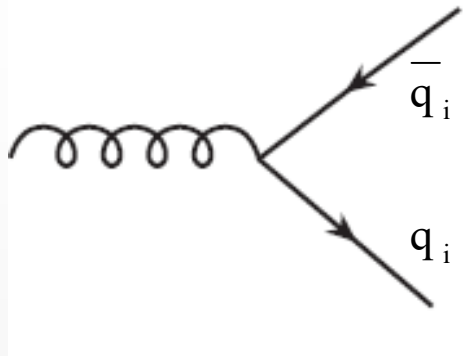

Gluon-quark-antiquark vertex

It is democratic! The gluon couples to each flavor with the same strength

$$q_i \rightarrow U_{ij} q_j$$

$$U \in U(3)_V \rightarrow U^\dagger U = 1$$

Chiral symmetry

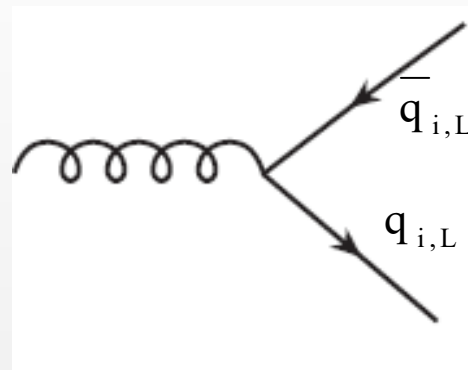
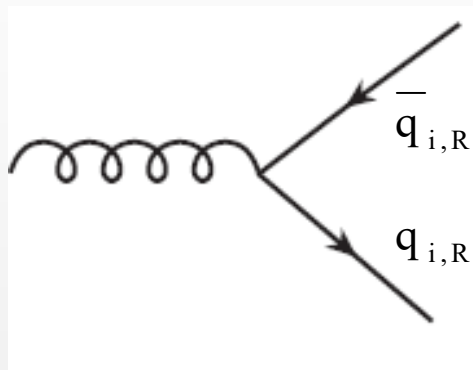
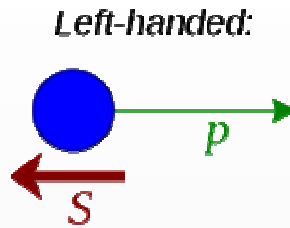
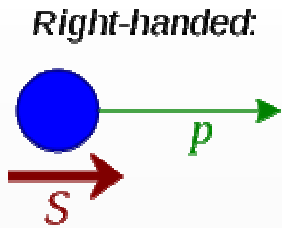

$$q_i = q_{i,R} + q_{i,L}$$

$$q_{i,R} = \frac{1}{2}(1 + \gamma^5)q_i$$

$$q_{i,L} = \frac{1}{2}(1 - \gamma^5)q_i$$

$$q_i = q_{i,R} + q_{i,L} \rightarrow U_{ij}^R q_{j,R} + U_{ij}^L q_{j,L}$$

$$U(3)_R \times U(3)_L = U(1)_{R+L} \times U(1)_{R-L} \times SU(3)_R \times SU(3)_L$$

baryon number anomaly U(1)_A

SSB into SU(3)_v

Chiral (or axial) anomaly: explicitly broken by quantum fluctuations

$$\partial^\mu (\bar{q}^i \gamma_\mu \gamma_5 q^i) = \frac{3g^2}{16\pi^2} \varepsilon^{\mu\nu\rho\sigma} \text{tr}(G_{\mu\nu} G_{\rho\sigma})$$

In the chiral limit ($m_i=0$) chiral symmetry is exact, but is **spontaneously broken** by the QCD vacuum

Symmetries of QCD and breakings



SU(3)_{color}: exact. Confinement: you never see color, but only white states.

Dilatation invariance: holds only at a classical level and in the chiral limit. Broken by quantum fluctuations (**scale anomaly**) and by quark masses.

SU(3)_R × SU(3)_L: holds in the chiral limit, but is broken by nonzero quark masses. Moreover, it is **spontaneously** broken to U(3)_{V=R+L}

U(1)_{A=R-L}: holds at a classical level, but is also broken by quantum fluctuations (**chiral anomaly**)

Conventional mesons: quark-antiquark states

Hadrons



The QCD Lagrangian contains 'colored' quarks and gluons. However, no 'colored' state has been seen.

Confinement: physical states are "white" and are called hadrons.

Hadrons can be:

Mesons: bosonic hadrons

Baryons: fermionic hadrons

A meson is **not necessarily** a quark-antiquark state.

A quark-antiquark state is a conventional meson.

Example of conventional quark-antiquark states: the ρ and the π mesons

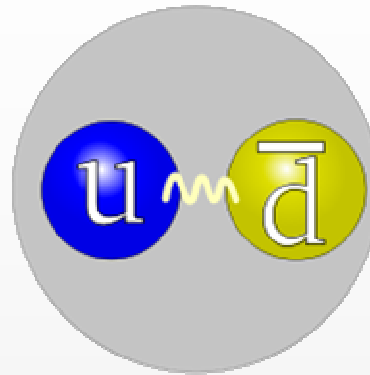

Rho-meson

$$m_{\rho^+} = 775 \text{ MeV}$$

Pion

$$m_{\pi^+} = 139 \text{ MeV}$$

$$m_u + m_d \approx 7 \text{ MeV}$$

$$|\rho^+\rangle \propto |u\bar{d}\rangle + \frac{1}{N_c} (|\pi^+\pi^0\rangle + \dots)$$

where

$$|u\bar{d}\rangle = |\text{valence } u + \text{valence } \bar{d} + \text{gluons}\rangle$$

Mass generation in QCD
is a nonpert. phenomenon
based on SSB

(mentioned previously).

Quark-antiquark mesons (PDG 2018)

$n \ 2s+1 \ell_J$	J^{PC}	$l = 1$ $\bar{u}d, \bar{u}d, \frac{1}{\sqrt{2}}(d\bar{d} - u\bar{u})$	$l = \frac{1}{2}$ $u\bar{s}, d\bar{s}; \bar{d}s, -\bar{u}s$	$l = 0$ f'	$l = 0$ f	θ_{quad} [°]	θ_{lin} [°]
$1 \ ^1S_0$	0^{-+}	π	K	η	$\eta'(958)$	-11.3	-24.5
$1 \ ^3S_1$	1^{--}	$\rho(770)$	$K^*(892)$	$\phi(1020)$	$\omega(782)$	39.2	36.5
$1 \ ^1P_1$	1^{+-}	$b_1(1235)$	K_{1B}^\dagger	$h_1(1380)$	$h_1(1170)$		
$1 \ ^3P_0$	0^{++}	$a_0(1450)$	$K_0^*(1430)$	$f_0(1710)$	$f_0(1370)$		
$1 \ ^3P_1$	1^{++}	$a_1(1260)$	K_{1A}^\dagger	$f_1(1420)$	$f_1(1285)$		
$1 \ ^3P_2$	2^{++}	$a_2(1320)$	$K_2^*(1430)$	$f_2'(1525)$	$f_2(1270)$	29.6	28.0
$1 \ ^1D_2$	2^{-+}	$\pi_2(1670)$	$K_2(1770)^\dagger$	$\eta_2(1870)$	$\eta_2(1645)$		
$1 \ ^3D_1$	1^{--}	$\rho(1700)$	$K^*(1680)$		$\omega(1650)$		
$1 \ ^3D_2$	2^{--}		$K_2(1820)$				
$1 \ ^3D_3$	3^{--}	$\rho_3(1690)$	$K_3^*(1780)$	$\phi_3(1850)$	$\omega_3(1670)$	31.8	30.8
$1 \ ^3F_4$	4^{++}	$a_4(2040)$	$K_4^*(2045)$		$f_4(2050)$		
$1 \ ^3G_5$	5^{--}	$\rho_5(2350)$	$K_5^*(2380)$				
$1 \ ^3H_6$	6^{++}	$a_6(2450)$			$f_6(2510)$		
$2 \ ^1S_0$	0^{-+}	$\pi(1300)$	$K(1460)$	$\eta(1475)$	$\eta(1295)$		
$2 \ ^3S_1$	1^{--}	$\rho(1450)$	$K^*(1410)$	$\phi(1680)$	$\omega(1420)$		
$3 \ ^1S_0$	0^{-+}	$\pi(1800)$			$\eta(1760)$		

Quark-antiquark mesons (PDG 2018)

$n^{2s+1}\ell_J$	J^{PC}	$l = 1$ $u\bar{d}, \bar{u}d, \frac{1}{\sqrt{2}}(d\bar{d} - u\bar{u})$	$l = \frac{1}{2}$ $u\bar{s}, d\bar{s}; \bar{d}s, -\bar{u}s$	$l = 0$ f'	$l = 0$ f	θ_{quad} [°]	θ_{lin} [°]
1^1S_0	0^{-+}	π	K	η	$\eta'(958)$	-11.3	-24.5
1^3S_1	1^{--}	$\rho(770)$	$K^*(892)$	$\phi(1020)$	$\omega(782)$	39.2	36.5
1^1P_1	1^{+-}	$b_1(1235)$	K_{1B}^\dagger	$h_1(1380)$	$h_1(1170)$		
1^3P_0	0^{++}	$a_0(1450)$	$K_0^*(1430)$	$f_0(1710)$	$f_0(1370)$		
1^3P_1	1^{++}	$a_1(1260)$	K_{1A}^\dagger	$f_1(1420)$	$f_1(1285)$		
1^3P_2	2^{++}	$a_2(1320)$	$K_2^*(1430)$	$f_2'(1525)$	$f_2(1270)$	29.6	28.0
1^1D_2	2^{-+}	$\pi_2(1670)$	$K_2(1770)^\dagger$	$\eta_2(1870)$	$\eta_2(1645)$		
1^3D_1	1^{--}	$\rho(1700)$	$K^*(1680)$		$\omega(1650)$		
1^3D_2	2^{--}		$K_2(1820)$				
1^3D_3	3^{--}	$\rho_3(1690)$	$K_3^*(1780)$	$\phi_3(1850)$	$\omega_3(1670)$	31.8	30.8
1^3F_4	4^{++}	$a_4(2040)$	$K_4^*(2045)$		$f_4(2050)$		
1^3G_5	5^{--}	$\rho_5(2350)$	$K_5^*(2380)$				
1^3H_6	6^{++}	$a_6(2450)$			$f_6(2510)$		
2^1S_0	0^{-+}	$\pi(1300)$	$K(1460)$	$\eta(1475)$	$\eta(1295)$		
2^3S_1	1^{--}	$\rho(1450)$	$K^*(1410)$	$\phi(1680)$	$\omega(1420)$		
3^1S_0	0^{-+}	$\pi(1800)$			$\eta(1760)$		

Some selected nonets

$n^{2S+1}L_J$	J^{PC}	I=1 $u\bar{d}, d\bar{u}$ $\frac{d\bar{d}-u\bar{u}}{\sqrt{2}}$	I=1/2 $u\bar{s}, d\bar{s}$ $s\bar{d}, s\bar{u}$	I=0 $\approx \frac{u\bar{u}+d\bar{d}}{\sqrt{2}}$	I=0 $\approx s\bar{s}$	Meson names	Chiral Partners
1^1S_0	0^{-+}	π	K	$\eta(547)$	$\eta'(958)$	Pseudoscalar	$J = 0$
1^3P_0	0^{++}	$a_0(1450)$	$K_0^*(1430)$	$f_0(1370)$	$f_0(1500)/f_0(1710)$	Scalar	
1^3S_1	1^{--}	$\rho(770)$	$K^*(892)$	$\omega(782)$	$\phi(1020)$	Vector	$J = 1$
1^3P_1	1^{++}	$a_1(1260)$	K_{1A}	$f_1(1285)$	$f_1'(1420)$	Axial-vector	
1^1P_1	1^{+-}	$b_1(1235)$	K_{1B}	$h_1(1170)$	$h_1(1415)$	Pseudovector	$J = 1^*$
1^3D_1	1^{--}	$\rho(1700)$	$K^*(1680)$	$\omega(1650)$	$\phi(???)$	Excited-vector	
1^3P_2	2^{++}	$a_2(1320)$	$K_2^*(1430)$	$f_2(1270)$	$f_2'(1525)$	Tensor	$J = 2$
1^3D_2	2^{--}	$\rho_2(???)$	$K_2(1820)$	$\omega_2(???)$	$\phi_2(???)$	Axial-tensor	
1^1D_2	2^{-+}	$\pi_2(1670)$	$K_2(1770)$	$\eta_2(1645)$	$\eta_2(1870)$	Pseudotensor	
1^3D_3	3^{--}	$\rho_3(1690)$	$K_3^*(1780)$	$\omega_3(1670)$	$\phi_3(1850)$	$J = 3$ - Tensor	

Chiral partners

$n^{2S+1}L_J$	J^{PC}	I=1 $u\bar{d}, d\bar{u}$ $\frac{d\bar{d}-u\bar{u}}{\sqrt{2}}$	I=1/2 $u\bar{s}, d\bar{s}$ $s\bar{d}, s\bar{u}$	I=0 $\approx \frac{u\bar{u}+d\bar{d}}{\sqrt{2}}$	I=0 $\approx s\bar{s}$	Meson names	Chiral Partners
1^1S_0	0^{-+}	π	K	$\eta(547)$	$\eta'(958)$	Pseudoscalar	$J = 0$
1^3P_0	0^{++}	$a_0(1450)$	$K_0^*(1430)$	$f_0(1370)$	$f_0(1500)/f_0(1710)$	Scalar	
1^3S_1	1^{--}	$\rho(770)$	$K^*(892)$	$\omega(782)$	$\phi(1020)$	Vector	$J = 1$
1^3P_1	1^{++}	$a_1(1260)$	K_{1A}	$f_1(1285)$	$f_1'(1420)$	Axial-vector	
1^1P_1	1^{+-}	$b_1(1235)$	K_{1B}	$h_1(1170)$	$h_1(1415)$	Pseudovector	$J = 1^*$
1^3D_1	1^{--}	$\rho(1700)$	$K^*(1680)$	$\omega(1650)$	$\phi(???)$	Excited-vector	
1^3P_2	2^{++}	$a_2(1320)$	$K_2^*(1430)$	$f_2(1270)$	$f_2'(1525)$	Tensor	$J = 2$
1^3D_2	2^{--}	$\rho_2(???)$	$K_2(1820)$	$\omega_2(???)$	$\phi_2(???)$	Axial-tensor	
1^1D_2	2^{-+}	$\pi_2(1670)$	$K_2(1770)$	$\eta_2(1645)$	$\eta_2(1870)$	Pseudotensor	
1^3D_3	3^{--}	$\rho_3(1690)$	$K_3^*(1780)$	$\omega_3(1670)$	$\phi_3(1850)$	$J = 3$ - Tensor	

TABLE I. Chiral multiplets, their currents, and transformations up to $J = 3$. [* and/or $f_0(1500)$; **a mix of.] The first two columns correspond to the assignment suggested in the Quark Model review of the PDG [8], to which we refer for further details and references (see also the discussion in the text).

$J^{PC}, {}^{2S+1}L_J$	$\begin{cases} I = 1(\bar{u}d, \bar{d}u, \frac{\bar{d}d - \bar{u}u}{\sqrt{2}}) \\ I = 1(-\bar{u}s, \bar{s}u, \bar{d}s, \bar{s}d) \\ I = 0(\frac{\bar{u}u + \bar{d}d}{\sqrt{2}}, \bar{s}s)** \end{cases}$	Microscopic currents	Chiral multiplet	Transformation under $SU(3)_L \times SU(3)_R \times U(1)_A$
$0^{-+}, {}^1S_0$	$\begin{cases} \pi \\ K \\ \eta, \eta'(958) \end{cases}$	$P^{ij} = \frac{1}{2} \bar{q}^j i\gamma^5 q^i$	$\Phi = S + iP$ ($\Phi^{ij} = \bar{q}_R^j q_L^i$)	$\Phi \rightarrow e^{-2i\alpha} U_L \Phi U_R^\dagger$
$0^{++}, {}^3P_0$	$\begin{cases} a_0(1450) \\ K_0^*(1430) \\ f_0(1370), f_0(1710)* \end{cases}$	$S^{ij} = \frac{1}{2} \bar{q}^j q^i$		
$1^{--}, {}^1S_1$	$\begin{cases} \rho(770) \\ K^*(892) \\ \omega(782), \phi(1020) \end{cases}$	$V_\mu^{ij} = \frac{1}{2} \bar{q}^j \gamma_\mu q^i$	$L_\mu = V_\mu + A_\mu$ ($L_\mu^{ij} = \bar{q}_L^j \gamma_\mu q_L^i$)	$L_\mu \rightarrow U_L L_\mu U_L^\dagger$
$1^{++}, {}^3P_1$	$\begin{cases} a_1(1260) \\ K_{1,A} \\ f_1(1285), f_1(1420) \end{cases}$	$A_\mu^{ij} = \frac{1}{2} \bar{q}^j \gamma^5 \gamma_\mu q^i$	$R_\mu = V_\mu - A_\mu$ ($R_\mu^{ij} = \bar{q}_R^j \gamma_\mu q_R^i$)	$R_\mu \rightarrow U_R R_\mu U_R^\dagger$
$1^{+-}, {}^1P_1$	$\begin{cases} b_1(1235) \\ K_{1,B} \\ h_1(1170), h_1(1380) \end{cases}$	$P_\mu^{ij} = -\frac{1}{2} \bar{q}^j \gamma^5 \overleftrightarrow{D}_\mu q^i$	$\Phi_\mu = S_\mu + iP_\mu$ ($\Phi_\mu^{ij} = \bar{q}_R^j i\overleftrightarrow{D}_\mu q_L^i$)	$\Phi_\mu \rightarrow e^{-2i\alpha} U_L \Phi_\mu U_R^\dagger$
$1^{--}, {}^3D_1$	$\begin{cases} \rho(1700) \\ K^*(1680) \\ \omega(1650), \phi(?) \end{cases}$	$S_\mu^{ij} = \frac{1}{2} \bar{q}^j i\overleftrightarrow{D}_\mu q^i$		
$2^{++}, {}^3P_2$	$\begin{cases} a_2(1320) \\ K_2^*(1430) \\ f_2(1270), f_2'(1525) \end{cases}$	$V_{\mu\nu}^{ij} = \frac{1}{2} \bar{q}^j (\gamma_\mu i\overleftrightarrow{D}_\nu + \dots) q^i$	$L_{\mu\nu} = V_{\mu\nu} + A_{\mu\nu}$ ($L_{\mu\nu}^{ij} = \bar{q}_L^j (\gamma_\mu i\overleftrightarrow{D}_\nu + \dots) q_L^i$)	$L_{\mu\nu} \rightarrow U_L L_{\mu\nu} U_L^\dagger$
$2^{--}, {}^3D_2$	$\begin{cases} \rho_2(?) \\ K_2(1820) \\ \omega_2(?), \phi_2(?) \end{cases}$	$A_{\mu\nu}^{ij} = \frac{1}{2} \bar{q}^j (\gamma^5 \gamma_\mu i\overleftrightarrow{D}_\nu + \dots) q^i$	$R_{\mu\nu} = V_{\mu\nu} - A_{\mu\nu}$ ($R_{\mu\nu}^{ij} = \bar{q}_R^j (\gamma_\mu \overleftrightarrow{D}_\nu + \dots) q_R^i$)	$R_{\mu\nu} \rightarrow U_R R_{\mu\nu} U_R^\dagger$
$2^{-+}, {}^1D_2$	$\begin{cases} \pi_2(1670) \\ K_2(1770) \\ \eta_2(1645), \eta_2(1870) \end{cases}$	$P_{\mu\nu}^{ij} = -\frac{1}{2} \bar{q}^j (i\gamma^5 \overleftrightarrow{D}_\mu \overleftrightarrow{D}_\nu + \dots) q^i$	$\Phi_{\mu\nu} = S_{\mu\nu} + iP_{\mu\nu}$ ($\Phi_{\mu\nu}^{ij} = \bar{q}_R^j (\overleftrightarrow{D}_\mu \overleftrightarrow{D}_\nu + \dots) q_L^i$)	$\Phi_{\mu\nu} \rightarrow e^{-2i\alpha} U_L \Phi_{\mu\nu} U_R^\dagger$
$2^{++}, {}^3F_2$	$\begin{cases} a_2(?) \\ K_2^*(?) \\ f_2(?), f_2'(?), f_2''(?) \end{cases}$	$S_{\mu\nu}^{ij} = -\frac{1}{2} \bar{q}^j (\overleftrightarrow{D}_\mu \overleftrightarrow{D}_\nu + \dots) q^i$		
$3^{--}, {}^3D_3$	$\begin{cases} \rho_3(1690) \\ K_3^*(1780) \\ \omega_3(1670), \phi_3(1850) \end{cases}$	\vdots	\vdots	\vdots

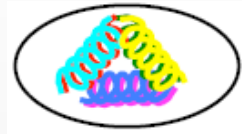

Table from:

F.G., R. Pisarski,
A. Koenigstein
Phys.Rev.D 97 (2018) 9,
091901
e-Print: 1709.07454

Non-conventional mesons: beyond qq

1) Glueballs



2) Hybrids

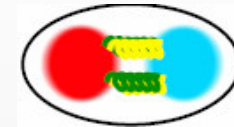

Compact diquark-antidiquark states



3) Four-quark states

Molecular states (a type of dynamical generation)



Companion poles (another type of dynamical generation)

Models for conventional mesons: from $J=3$ downwards

Strategy



- For a given nonet , write down the corresponding model-Lagrangian respecting flavor (or if possible chiral) symmetry.
- Consider only C, P, invariant terms
- Calculate decays in all possible channels (first at tree-level, in some selected case including finite width or loop effects;
- Fit free parameters to known experimental value;
- Make postdictions and predictions.

Mesons with J=3

$n^{2S+1}L_J$	J^{PC}	I=1 $u\bar{d}, d\bar{u}$ $\frac{d\bar{d}-u\bar{u}}{\sqrt{2}}$	I=1/2 $u\bar{s}, d\bar{s}$ $s\bar{d}, s\bar{u}$	I=0 $\approx \frac{u\bar{u}+d\bar{d}}{\sqrt{2}}$	I=0 $\approx s\bar{s}$	Meson names	Chiral Partners
1^1S_0	0^{-+}	π	K	$\eta(547)$	$\eta'(958)$	Pseudoscalar	$J = 0$
1^3P_0	0^{++}	$a_0(1450)$	$K_0^*(1430)$	$f_0(1370)$	$f_0(1500)/f_0(1710)$	Scalar	
1^3S_1	1^{--}	$\rho(770)$	$K^*(892)$	$\omega(782)$	$\phi(1020)$	Vector	$J = 1$
1^3P_1	1^{++}	$a_1(1260)$	K_{1A}	$f_1(1285)$	$f_1'(1420)$	Axial-vector	
1^1P_1	1^{+-}	$b_1(1235)$	K_{1B}	$h_1(1170)$	$h_1(1415)$	Pseudovector	$J = 1^*$
1^3D_1	1^{--}	$\rho(1700)$	$K^*(1680)$	$\omega(1650)$	$\phi(???)$	Excited-vector	
1^3P_2	2^{++}	$a_2(1320)$	$K_2^*(1430)$	$f_2(1270)$	$f_2'(1525)$	Tensor	$J = 2$
1^3D_2	2^{--}	$\rho_2(???)$	$K_2(1820)$	$\omega_2(???)$	$\phi_2(???)$	Axial-tensor	
1^1D_2	2^{-+}	$\pi_2(1670)$	$K_2(1770)$	$\eta_2(1645)$	$\eta_2(1870)$	Pseudotensor	
1^3D_3	3^{--}	$\rho_3(1690)$	$K_3^*(1780)$	$\omega_3(1670)$	$\phi_3(1850)$	$J = 3$ - Tensor	

Phenomenology of $J^{PC} = 3^{--}$ tensor mesons

Shahriyar Jafarzade ^{*}

Institute of Physics, Jan Kochanowski University, ul. Uniwersytecka 7, P-25-406 Kielce, Poland

Adrian Koenigstein [†]

*Institute for Theoretical Physics, Goethe-University, Max-von-Laue-Str. 1,
D-60438 Frankfurt am Main, Germany*

Francesco Giacosa [‡]

*Institute of Physics, Jan Kochanowski University, ul. Uniwersytecka 7, P-25-406 Kielce, Poland,
and Institute for Theoretical Physics, Goethe-University, Max-von-Laue-Str. 1,
D-60438 Frankfurt am Main, Germany*



(Received 19 January 2021; accepted 15 April 2021; published 28 May 2021)

We study the strong and radiative decays of the antiquark-quark ground state $J^{PC} = 3^{--}$ ($n^{2S+1}L_J = 1^3D_3$) nonet $\{\rho_3(1690), K_3^*(1780), \phi_3(1850), \omega_3(1670)\}$ in the framework of an effective quantum field theory approach, based on the $SU_V(3)$ -flavor symmetry. The effective model is fitted to experimental data listed by the Particle Data Group. We predict numerous experimentally unknown decay widths and branching ratios. An overall agreement of theory (fit and predictions) with experimental data confirms the $\bar{q}q$ nature of the states and qualitatively validates the effective approach. Naturally, experimental clarification as well as advanced theoretical description is needed for trustworthy quantitative predictions, which is observed from some of the decay channels. Besides conventional spin-3 mesons, theoretical predictions for ratios of strong and radiative decays of a hypothetical glueball state $G_3(4200)$ with $J^{PC} = 3^{--}$ are also presented.

Decays of J=3-mesons

TABLE III. Effective relativistic interaction terms describing the strong decays of mesons with $J^{PC} = 3^{--}$.

Decay mode	Interaction Lagrangians
$3^{--} \rightarrow 0^{++} + 0^{--}$	$\mathcal{L}_{w_3pp} = g_{w_3pp} \text{tr}[W_3^{\mu\nu\rho}[P, (\partial_\mu \partial_\nu \partial_\rho P)]_-]$
$3^{--} \rightarrow 0^{++} + 1^{--}$	$\mathcal{L}_{w_3v_1p} = g_{w_3v_1p} \epsilon^{\mu\nu\rho\sigma} \text{tr}[W_{3,\mu\alpha\beta}\{(\partial_\nu V_{1,\rho}), (\partial^\alpha \partial^\beta \partial_\sigma P)\}_+]$
$3^{--} \rightarrow 0^{++} + 2^{++}$	$\mathcal{L}_{w_3a_2p} = g_{w_3a_2p} \epsilon_{\mu\rho\sigma} \text{tr}[W_3^{\mu\alpha\beta}\{(\partial^\nu A_2^\rho), (\partial^\sigma \partial^\beta P)\}_-]$
$3^{--} \rightarrow 0^{++} + 1^{+-}$	$\mathcal{L}_{w_3b_1p} = g_{w_3b_1p} \text{tr}[W_3^{\mu\nu\rho}\{B_{1,\mu}, (\partial_\nu \partial_\rho P)\}_+]$
$3^{--} \rightarrow 0^{++} + 1^{++}$	$\mathcal{L}_{w_3a_1p} = g_{w_3a_1p} \text{tr}[W_3^{\mu\nu\rho}[A_{1,\mu}, (\partial_\nu \partial_\rho P)]_-]$
$3^{--} \rightarrow 1^{--} + 1^{--}$	$\mathcal{L}_{w_3v_1v_1} = g_{w_3v_1v_1} \text{tr}[W_3^{\mu\nu\rho}\{(\partial_\mu V_{1,\nu}), V_{1,\rho}\}_-]$

$$W_3^{\mu\nu\rho} = \frac{1}{\sqrt{2}} \begin{pmatrix} \frac{\omega_{3,N}^{\mu\nu\rho} + \rho_3^{0\mu\nu\rho}}{\sqrt{2}} & \rho_3^{+\mu\nu\rho} & K_3^{+\mu\nu\rho} \\ \rho_3^{-\mu\nu\rho} & \frac{\omega_{3,N}^{\mu\nu\rho} - \rho_3^{0\mu\nu\rho}}{\sqrt{2}} & K_3^{0\mu\nu\rho} \\ K_3^{-\mu\nu\rho} & \bar{K}_3^{0\mu\nu\rho} & \omega_{3,S}^{\mu\nu\rho} \end{pmatrix}$$

$$P = \frac{1}{\sqrt{2}} \begin{pmatrix} \frac{\eta_N + \pi^0}{\sqrt{2}} & \pi^+ & K^+ \\ \pi^- & \frac{\eta_N - \pi^0}{\sqrt{2}} & K^0 \\ K^- & \bar{K}^0 & \eta_S \end{pmatrix}$$

$$V_1^\mu = \frac{1}{\sqrt{2}} \begin{pmatrix} \frac{\omega_{1,N}^\mu + \rho_1^{0\mu}}{\sqrt{2}} & \rho_1^{+\mu} & K_1^{*+\mu} \\ \rho_1^{-\mu} & \frac{\omega_{1,N}^\mu - \rho_1^{0\mu}}{\sqrt{2}} & K_1^{*0\mu} \\ K_1^{*-\mu} & \bar{K}_1^{*0\mu} & \omega_{1,S}^\mu \end{pmatrix}$$

TABLE IV. Decay amplitudes for different decay modes.

Decay mode	$\frac{1}{7} \mathcal{M} ^2$
$3^{--} \rightarrow 0^{++} + 0^{--}$	$g_{w_3pp}^2 \frac{2}{35} \vec{k}_{p^{(1)},p^{(2)}} ^6$
$3^{--} \rightarrow 0^{++} + 1^{--}$	$g_{w_3v_1p}^2 \frac{8}{105} \vec{k}_{v_1,p} ^6 m_{w_3}^2$
$3^{--} \rightarrow 0^{++} + 2^{++}$	$g_{w_3a_2p}^2 \frac{2}{105} \vec{k}_{a_2,p} ^4 \frac{m_{w_3}^2}{m_{a_2}^2} (2 \vec{k}_{a_2,p} ^2 + 7m_{a_2}^2)$
$3^{--} \rightarrow 0^{++} + 1^{+-}$	$g_{w_3b_1p}^2 \frac{2}{105} \vec{k}_{b_1,p} ^4 (7 + 3 \frac{ \vec{k}_{b_1,p} ^2}{m_{b_1}^2})$
$3^{--} \rightarrow 0^{++} + 1^{++}$	$g_{w_3a_1p}^2 \frac{2}{105} \vec{k}_{a_1,p} ^4 (7 + 3 \frac{ \vec{k}_{a_1,p} ^2}{m_{a_1}^2})$
$3^{--} \rightarrow 1^{--} + 1^{--}$	$g_{w_3v_1v_1}^2 \frac{1}{105} (m_{v_1^{(1)}}^2 m_{v_1^{(2)}}^2)^{-1} \vec{k}_{v_1^{(1)},v_1^{(2)}} ^2 [6 \vec{k}_{v_1^{(1)},v_1^{(2)}} ^4 + 35m_{v_1^{(1)}}^2 m_{v_1^{(2)}}^2 + 14 \vec{k}_{v_1^{(1)},v_1^{(2)}} ^2 (m_{v_1^{(1)}}^2 + m_{v_1^{(2)}}^2)]$

Results (post- and predictions)



TABLE V. Decays of $J^{PC} = 3^{--}$ mesons into two pseudoscalars. Experimental data is taken from Ref. [1].

Decay process	Theory Γ/MeV	Experiment Γ/MeV
$\rho_3(1690) \rightarrow \pi\pi$	32.7 ± 2.3	38.0 ± 3.2
$\rho_3(1690) \rightarrow \bar{K}K$	4.0 ± 0.3	2.54 ± 0.45
$K_3^*(1780) \rightarrow \pi\bar{K}$	18.5 ± 1.3	29.9 ± 4.3
$K_3^*(1780) \rightarrow \bar{K}\eta$	7.4 ± 0.5	48 ± 22
$K_3^*(1780) \rightarrow \bar{K}\eta'(958)$	0.021 ± 0.001	
$\omega_3(1670) \rightarrow \bar{K}K$	3.0 ± 0.2	
$\phi_3(1850) \rightarrow \bar{K}K$	18.8 ± 1.3	Seen

TABLE VII. Theoretical predictions for the radiative decays $W_3 \rightarrow \gamma P$.

Decay process	Theory Γ/keV
$\rho_3^{\pm/0}(1690) \rightarrow \gamma\pi^{\pm/0}$	69 ± 14
$\rho_3^0(1690) \rightarrow \gamma\eta$	157 ± 32
$\rho_3^0(1690) \rightarrow \gamma\eta'(958)$	20 ± 4
$K_3^\pm(1780) \rightarrow \gamma K^\pm$	58 ± 12
$K_3^0(1780) \rightarrow \gamma K^0$	231 ± 48
$\omega_3(1670) \rightarrow \gamma\pi^0$	560 ± 120
$\omega_3(1670) \rightarrow \gamma\eta$	19 ± 4
$\omega_3(1670) \rightarrow \gamma\eta'(958)$	1.4 ± 0.3
$\phi_3(1850) \rightarrow \gamma\pi^0$	4 ± 1
$\phi_3(1850) \rightarrow \gamma\eta$	129 ± 26
$\phi_3(1850) \rightarrow \gamma\eta'(958)$	35 ± 7

TABLE VI. Decays of $J^{PC} = 3^{--}$ mesons into a pseudoscalar-vector pair. Experimental data taken from Ref. [1].

Decay process	Theory Γ/MeV	Experiment Γ/MeV
$\rho_3(1690) \rightarrow \rho(770)\eta$	3.8 ± 0.8	Seen
$\rho_3(1690) \rightarrow \bar{K}^*(892)K$	3.4 ± 0.7	
$\rho_3(1690) \rightarrow \omega(782)\pi$	35.8 ± 7.4	25.8 ± 9.8
$\rho_3(1690) \rightarrow \phi(1020)\pi$	0.036 ± 0.007	
$K_3^*(1780) \rightarrow \rho(770)K$	16.8 ± 3.5	49.3 ± 15.7
$K_3^*(1780) \rightarrow \bar{K}^*(892)\pi$	27.2 ± 5.6	31.8 ± 9.0
$K_3^*(1780) \rightarrow \bar{K}^*(892)\eta$	0.09 ± 0.02	
$K_3^*(1780) \rightarrow \omega(782)\bar{K}$	4.3 ± 0.9	
$K_3^*(1780) \rightarrow \phi(1020)\bar{K}$	1.2 ± 0.3	
$\omega_3(1670) \rightarrow \rho(770)\pi$	97 ± 20	Seen
$\omega_3(1670) \rightarrow \bar{K}^*(892)K$	2.9 ± 0.6	
$\omega_3(1670) \rightarrow \omega(782)\eta$	2.8 ± 0.6	
$\omega_3(1670) \rightarrow \phi(1020)\eta$	$(7.6 \pm 1.6) \times 10^{-6}$	
$\phi_3(1850) \rightarrow \rho(770)\pi$	1.1 ± 0.2	
$\phi_3(1850) \rightarrow \bar{K}^*(892)K$	35.5 ± 7.3	Seen
$\phi_3(1850) \rightarrow \omega(782)\eta$	0.015 ± 0.003	
$\phi_3(1850) \rightarrow \omega(782)\eta'(958)$	0.003 ± 0.001	
$\phi_3(1850) \rightarrow \phi(1020)\eta$	3.8 ± 0.8	

Isoscalar mixing is small

$$\begin{pmatrix} \omega_3(1670) \\ \phi_3(1850) \end{pmatrix} = \begin{pmatrix} \cos \beta_{w_3} & \sin \beta_{w_3} \\ -\sin \beta_{w_3} & \cos \beta_{w_3} \end{pmatrix} \begin{pmatrix} \omega_{3,N} \\ \omega_{3,S} \end{pmatrix}$$

$$\beta_{w_3} = 3.5^\circ$$

Tensor and (axial-)tensors

$n^{2S+1}L_J$	J^{PC}	I=1 $u\bar{d}, d\bar{u}$ $\frac{d\bar{d}-u\bar{u}}{\sqrt{2}}$	I=1/2 $u\bar{s}, d\bar{s}$ $s\bar{d}, s\bar{u}$	I=0 $\approx \frac{u\bar{u}+d\bar{d}}{\sqrt{2}}$	I=0 $\approx s\bar{s}$	Meson names	Chiral Partners
1^1S_0	0^{-+}	π	K	$\eta(547)$	$\eta'(958)$	Pseudoscalar	$J = 0$
1^3P_0	0^{++}	$a_0(1450)$	$K_0^*(1430)$	$f_0(1370)$	$f_0(1500)/f_0(1710)$	Scalar	
1^3S_1	1^{--}	$\rho(770)$	$K^*(892)$	$\omega(782)$	$\phi(1020)$	Vector	$J = 1$
1^3P_1	1^{++}	$a_1(1260)$	K_{1A}	$f_1(1285)$	$f_1'(1420)$	Axial-vector	
1^1P_1	1^{+-}	$b_1(1235)$	K_{1B}	$h_1(1170)$	$h_1(1415)$	Pseudovector	$J = 1^*$
1^3D_1	1^{--}	$\rho(1700)$	$K^*(1680)$	$\omega(1650)$	$\phi(???)$	Excited-vector	
1^3P_2	2^{++}	$a_2(1320)$	$K_2^*(1430)$	$f_2(1270)$	$f_2'(1525)$	Tensor	$J = 2$
1^3D_2	2^{--}	$\rho_2(???)$	$K_2(1820)$	$\omega_2(???)$	$\phi_2(???)$	Axial-tensor	
1^1D_2	2^{-+}	$\pi_2(1670)$	$K_2(1770)$	$\eta_2(1645)$	$\eta_2(1870)$	Pseudotensor	
1^3D_3	3^{--}	$\rho_3(1690)$	$K_3^*(1780)$	$\omega_3(1670)$	$\phi_3(1850)$	$J = 3$ - Tensor	

Based on:

PHYSICAL REVIEW D **106**, 036008 (2022)

From well-known tensor mesons to yet unknown axial-tensor mesons

Shahriyar Jafarzade¹,¹ Arthur Vereijken,¹ Milena Piotrowska,¹ and Francesco Giacosa^{1,2}

¹*Institute of Physics, Jan Kochanowski University, ulica Uniwersytecka 7, 25-406 Kielce, Poland*

²*Institute for Theoretical Physics, J. W. Goethe University,
Max-von-Laue-Straße 1, 60438 Frankfurt am Main, Germany*

 (Received 4 April 2022; accepted 25 July 2022; published 10 August 2022)

While the ground-state tensor ($J^{PC} = 2^{++}$) mesons $a_2(1320)$, $K_2^*(1430)$, $f_2(1270)$, and $f_2'(1525)$ are well known experimentally and form an almost ideal nonet of quark-antiquark states, their chiral partners, the ground-states axial-tensor ($J^{PC} = 2^{-+}$) mesons are poorly settled: only the kaonic member $K_2(1820)$ of the nonet has been experimentally found, whereas the isovector state ρ_2 and two isoscalar states ω_2 and ϕ_2 are still missing. Here, we study masses, strong, and radiative decays of tensor and axial-tensor mesons within a chiral model that links them: the established tensor mesons are used to test the model and to determine its parameters, and subsequently various predictions for their chiral partners, the axial-tensor mesons, are obtained. The results are compared to current lattice QCD outcomes as well as to other theoretical approaches and show that the ground-state axial-tensor mesons are expected to be quite broad, the vector-pseudoscalar mode being the most prominent decay mode followed by the tensor-pseudoscalar one. Nonetheless, their experimental finding seems to be possible in ongoing and/or future experiments.

DOI: 10.1103/PhysRevD.106.036008

Building the Lagrangian

$2^{++}, {}^3P_2$	$\begin{cases} a_2(1320) \\ K_2^*(1430) \\ f_2(1270), f_2'(1525) \end{cases}$	$V_{\mu\nu}^{ij} = \frac{1}{2} \bar{q}^j (\gamma_\mu i \overleftrightarrow{D}_\nu + \dots) q^i$	$L_{\mu\nu} = V_{\mu\nu} + A_{\mu\nu}$ $(L_{\mu\nu}^{ij} = \bar{q}_L^j (\gamma_\mu i \overleftrightarrow{D}_\nu + \dots) q_L^i)$	$L_{\mu\nu} \rightarrow U_L L_{\mu\nu} U_L^\dagger$
$2^{--}, {}^3D_2$	$\begin{cases} \rho_2(?) \\ K_2(1820) \\ \omega_2(?), \phi_2(?) \end{cases}$	$A_{\mu\nu}^{ij} = \frac{1}{2} \bar{q}^j (\gamma^5 \gamma_\mu i \overleftrightarrow{D}_\nu + \dots) q^i$	$R_{\mu\nu} = V_{\mu\nu} - A_{\mu\nu}$ $(R_{\mu\nu}^{ij} = \bar{q}_R^j (\gamma_\mu i \overleftrightarrow{D}_\nu + \dots) q_R^i)$	$R_{\mu\nu} \rightarrow U_R R_{\mu\nu} U_R^\dagger$

$$\mathcal{L}_{g_2^{\text{ten}}} = \frac{g_2^{\text{ten}}}{2} \left(\text{Tr} \left[\mathbf{L}_{\mu\nu} \{L^\mu, L^\nu\} \right] + \text{Tr} \left[\mathbf{R}_{\mu\nu} \{R^\mu, R^\nu\} \right] \right)$$

$$\begin{aligned} 2^{++} &\longrightarrow 0^{-+} + 0^{-+} ; \\ 2^{--} &\longrightarrow 0^{-+} + 1^{--} . \end{aligned}$$

Also in this case: small isoscalar mixing angle

$$\begin{pmatrix} f_2(1270) \\ f_2'(1525) \end{pmatrix} = \begin{pmatrix} \cos \beta_T & \sin \beta_T \\ -\sin \beta_T & \cos \beta_T \end{pmatrix} \begin{pmatrix} f_{2,N} \\ f_{2,S} \end{pmatrix}$$

$$\beta_T = (3.16 \pm 0.81)^\circ$$

Postdictions (left) predictions (right)

Decay process (in model)	eLSM (MeV)	PDG (MeV)
$a_2(1320) \rightarrow \bar{K} K$	4.06 ± 0.14	$7.0^{+2.0}_{-1.5} \leftrightarrow (4.9 \pm 0.8)\%$
$a_2(1320) \rightarrow \pi \eta$	25.37 ± 0.87	$18.5 \pm 3.0 \leftrightarrow (14.5 \pm 1.2)\%$
$a_2(1320) \rightarrow \pi \eta'(958)$	1.01 ± 0.03	$0.58 \pm 0.10 \leftrightarrow (0.55 \pm 0.09)\%$
$K_2^*(1430) \rightarrow \pi \bar{K}$	44.82 ± 1.54	$49.9 \pm 1.9 \leftrightarrow (49.9 \pm 0.6)\%$
$f_2(1270) \rightarrow \bar{K} K$	3.54 ± 0.29	$8.5 \pm 0.8 \leftrightarrow (4.6^{+0.5}_{-0.4})\%$
$f_2(1270) \rightarrow \pi \pi$	168.82 ± 3.89	$157.2^{+4.0}_{-1.1} \leftrightarrow (84.2^{+2.9}_{-0.9})\%$
$f_2(1270) \rightarrow \eta \eta$	0.67 ± 0.03	$0.75 \pm 0.14 \leftrightarrow (0.4 \pm 0.08)\%$
$f_2'(1525) \rightarrow \bar{K} K$	23.72 ± 0.60	$75 \pm 4 \leftrightarrow (87.6 \pm 2.2)\%$
$f_2'(1525) \rightarrow \pi \pi$	0.67 ± 0.14	$0.71 \pm 0.14 \leftrightarrow (0.83 \pm 0.16)\%$
$f_2'(1525) \rightarrow \eta \eta$	1.81 ± 0.05	$9.9 \pm 1.9 \leftrightarrow (11.6 \pm 2.2)\%$

Decay process (in model)	eLSM (MeV)	PDG-2020 (MeV)
$a_2(1320) \rightarrow \rho(770) \pi$	71.0 ± 2.6	$73.61 \pm 3.35 \leftrightarrow (70.1 \pm 2.7)\%$
$K_2^*(1430) \rightarrow \bar{K}^*(892) \pi$	27.9 ± 1.0	$26.92 \pm 2.14 \leftrightarrow (24.7 \pm 1.6)\%$
$K_2^*(1430) \rightarrow \rho(770) K$	10.3 ± 0.4	$9.48 \pm 0.97 \leftrightarrow (8.7 \pm 0.8)\%$
$K_2^*(1430) \rightarrow \omega(782) \bar{K}$	3.5 ± 0.1	$3.16 \pm 0.88 \leftrightarrow (2.9 \pm 0.8)\%$
$f_2'(1525) \rightarrow \bar{K}^*(892) K + c.c.$	19.89 ± 0.73	

Decay process (in model)	eLSM (MeV)
$\rho_2(?) \rightarrow \rho(770) \eta$	$\approx 99 \pm 50$
$\rho_2(?) \rightarrow \bar{K}^*(892) K + c.c.$	$\approx 85 \pm 43$
$\rho_2(?) \rightarrow \omega(782) \pi$	$\approx 419 \pm 210$
$\rho_2(?) \rightarrow \phi(1020) \pi$	≈ 0.8
$K_{2,A} \rightarrow \rho(770) K$	$\approx 195 \pm 98$
$K_{2,A} \rightarrow \bar{K}^*(892) \pi$	$\approx 316 \pm 158$
$K_{2,A} \rightarrow \bar{K}^*(892) \eta$	≈ 0.01
$K_{2,A} \rightarrow \omega(782) \bar{K}$	$\approx 51 \pm 26$
$K_{2,A} \rightarrow \phi(1020) \bar{K}$	$\approx 50 \pm 25$
$\omega_{2,N} \rightarrow \rho(770) \pi$	$\approx 1314 \pm 657$
$\omega_{2,N} \rightarrow \bar{K}^*(892) K + c.c.$	$\approx 85 \pm 43$
$\omega_{2,N} \rightarrow \omega(782) \eta$	$\approx 93 \pm 47$
$\omega_{2,N} \rightarrow \phi(1020) \eta$	≈ 0.06
$\omega_{2,S} \rightarrow \bar{K}^*(892) K + c.c.$	$\approx 510 \pm 255$
$\omega_{2,S} \rightarrow \omega(782) \eta$	$\approx 1.0 \pm 0.5$
$\omega_{2,S} \rightarrow \omega(782) \eta'(958)$	≈ 0.3
$\omega_{2,S} \rightarrow \phi(1020) \eta$	$\approx 101 \pm 51$

Decay process (in model)	eLSM (MeV)
$\rho_2(?) \rightarrow a_2(1320) \pi$	≈ 88
$K_{2,A} \rightarrow K_2^*(1430) \pi$	≈ 49
$K_{2,A} \rightarrow a_2(1320) K$	≈ 84
$K_{2,A} \rightarrow f_2(1270) K$	≈ 4
$\omega_{2,S} \rightarrow K_2^*(1430) K + c.c.$	≈ 15

Pseudotensor mesons

$n^{2S+1}L_J$	J^{PC}	I=1 $u\bar{d}, d\bar{u}$ $\frac{d\bar{d}-u\bar{u}}{\sqrt{2}}$	I=1/2 $u\bar{s}, d\bar{s}$ $s\bar{d}, s\bar{u}$	I=0 $\approx \frac{u\bar{u}+d\bar{d}}{\sqrt{2}}$	I=0 $\approx s\bar{s}$	Meson names	Chiral Partners
1^1S_0	0^{-+}	π	K	$\eta(547)$	$\eta'(958)$	Pseudoscalar	$J = 0$
1^3P_0	0^{++}	$a_0(1450)$	$K_0^*(1430)$	$f_0(1370)$	$f_0(1500)/f_0(1710)$	Scalar	
1^3S_1	1^{--}	$\rho(770)$	$K^*(892)$	$\omega(782)$	$\phi(1020)$	Vector	$J = 1$
1^3P_1	1^{++}	$a_1(1260)$	K_{1A}	$f_1(1285)$	$f'_1(1420)$	Axial-vector	
1^1P_1	1^{+-}	$b_1(1235)$	K_{1B}	$h_1(1170)$	$h_1(1415)$	Pseudovector	$J = 1^*$
1^3D_1	1^{--}	$\rho(1700)$	$K^*(1680)$	$\omega(1650)$	$\phi(???)$	Excited-vector	
1^3P_2	2^{++}	$a_2(1320)$	$K_2^*(1430)$	$f_2(1270)$	$f'_2(1525)$	Tensor	$J = 2$
1^3D_2	2^{--}	$\rho_2(???)$	$K_2(1820)$	$\omega_2(???)$	$\phi_2(???)$	Axial-tensor	
1^1D_2	2^{-+}	$\pi_2(1670)$	$K_2(1770)$	$\eta_2(1645)$	$\eta_2(1870)$	Pseudotensor	
1^3D_3	3^{--}	$\rho_3(1690)$	$K_3^*(1780)$	$\omega_3(1670)$	$\phi_3(1850)$	$J = 3$ - Tensor	

Phenomenology of pseudotensor mesons and the pseudotensor glueball

Adrian Koenigstein^{1,2,a} and Francesco Giacosa^{3,1}

¹ Institute for Theoretical Physics, Johann Wolfgang Goethe University, Max-von-Laue-Str. 1, 60438 Frankfurt am Main, Germany

² Frankfurt Institute for Advanced Studies, Ruth-Moufang-Str. 1, 60438 Frankfurt am Main, Germany

³ Institute of Physics, Jan Kochanowski University, ul. Świetokrzyska 15, 25-406 Kielce, Poland

Received: 6 September 2016 / Revised: 11 November 2016

Published online: 9 December 2016 – © Società Italiana di Fisica / Springer-Verlag 2016

Communicated by R. Alkofer

Abstract. We study the decays of the pseudotensor mesons ($\pi_2(1670)$, $K_2(1770)$, $\eta_2(1645)$, $\eta_2(1870)$) interpreted as the ground-state nonet of 1^1D_2 $\bar{q}q$ states using interaction Lagrangians which couple them to pseudoscalar, vector, and tensor mesons. While the decays of $\pi_2(1670)$ and $K_2(1770)$ can be well described, the decays of the isoscalar states $\eta_2(1645)$ and $\eta_2(1870)$ can be brought in agreement with the present experimental data only if the mixing angle between nonstrange and strange states is surprisingly large (about -42° , similar to the mixing in the pseudoscalar sector, in which the chiral anomaly is active). Such a large mixing angle is however at odd with all other conventional quark-antiquark nonets: if confirmed, a deeper study of its origin will be needed in the future. Moreover, the $\bar{q}q$ assignment of pseudotensor states predicts that the ratio $[\eta_2(1870) \rightarrow a_2(1320)\pi]/[\eta_2(1870) \rightarrow f_2(1270)\eta]$ is about 23.5. This value is in agreement with Barberis *et al.*, (20.4 ± 6.6) , but disagrees with the recent reanalysis of Anisovich *et al.*, (1.7 ± 0.4) . Future experimental studies are necessary to understand this puzzle. If Anisovich's value is confirmed, a simple nonet of pseudoscalar mesons cannot be able to describe data (different assignments and/or additional states, such as an hybrid state, will be needed). In the end, we also evaluate the decays of a pseudoscalar glueball into the aforementioned conventional $\bar{q}q$ states: a sizable decay into $K_2^*(1430)K$ and $a_2(1230)\pi$ together with a vanishing decay into pseudoscalar-vector pairs (such as $\rho(770)\pi$ and $K^*(892)K$) are expected. This information can be helpful in future studies of glueballs at the ongoing BESIII and at the future PANDA experiments.

ArXiv: 1608.08777

Other considerations on pseudotensor mesons



Our model

- couples pseudotensor mesons to pseudoscalar, vector and tensor mesons.
- reproduces present experimental data for $\pi_2(1670)$ and $K_2(1770)$.
- identifies $\eta_2(1870)$ and $\eta_2(1645)$ with the $\bar{q}q$ pseudotensor meson nonet, if non-strange-strange mixing is large.
- predicts a large non-strange-strange mixing angle $\beta_{pt} \approx -40^\circ$ in the isoscalar sector.
- contributes to the discussion on conflicting experimental results for the branching ratios of $\eta_2(1870)$.

Results for $I = 1$ and $I = 1/2$

Decay process	Theory (MeV)	Experiment (MeV)
$\pi_2(1670) \rightarrow \rho(770) \pi$	80.6 ± 10.8	80.6 ± 10.8
$\pi_2(1670) \rightarrow f_2(1270) \pi$	146.4 ± 9.7	146.4 ± 9.7
$\pi_2(1670) \rightarrow \bar{K}^*(892) K + c.c.$	11.7 ± 1.6	10.9 ± 3.7
$\pi_2(1670) \rightarrow \bar{K}_2^*(1430) K + c.c.$	0	
$\pi_2(1670) \rightarrow f_2'(1525) \pi$	0.1 ± 0.1	
$\pi_2(1670) \rightarrow a_2(1320) \pi$	0	not seen
$\pi_2(1670) \rightarrow a_2(1320) \eta$	0	
$\pi_2(1670) \rightarrow a_2(1320) \eta'(958)$	0	
$K_2(1770) \rightarrow \rho(770) K$	22.2 ± 3.0	
$K_2(1770) \rightarrow \bar{K}^*(892) \pi$	25.5 ± 3.4	seen
$K_2(1770) \rightarrow \bar{K}^*(892) \eta$	10.5 ± 1.4	
$K_2(1770) \rightarrow \bar{K}^*(892) \eta'(958)$	0	
$K_2(1770) \rightarrow \omega(782) K$	8.3 ± 1.1	seen
$K_2(1770) \rightarrow \phi(1020) K$	4.2 ± 0.6	seen
$K_2(1770) \rightarrow a_2(1320) K$	0	
$K_2(1770) \rightarrow \bar{K}_2^*(1430) \pi$	84.5 ± 5.6	dominant
$K_2(1770) \rightarrow \bar{K}_2^*(1430) \eta$	0	
$K_2(1770) \rightarrow \bar{K}_2^*(1430) \eta'(958)$	0	
$K_2(1770) \rightarrow f_2(1270) K$	5.8 ± 0.4	seen
$K_2(1770) \rightarrow f_2'(1525) K$	0	

Table 4: Decays of $I = 1$ and $I = 1/2$ pseudotensor states. The first two entries were used to determine the coupling constants of the model, see Eq. (3.2). The total decay widths are $\Gamma_{\pi_2(1670)}^{\text{tot}} = (260 \pm 9)$ MeV and $\Gamma_{K_2(1770)}^{\text{tot}} = (186 \pm 14)$ MeV.

ArXiv: 1608.08777

Results in the isoscalar (large isoscalar mixing!)

Decay process	Theory (MeV) ($\beta_{pt} = -42^\circ$)	Experiment (MeV)
$\eta_2(1645) \rightarrow \bar{K}^*(892) K + c.c.$	24.7	seen
$\eta_2(1645) \rightarrow a_2(1320) \pi$	186.5	
$\eta_2(1645) \rightarrow \bar{K}_2^*(1430) K + c.c.$	0	
$\eta_2(1645) \rightarrow f_2(1270) \eta$	0	not seen
$\eta_2(1645) \rightarrow f_2(1270) \eta'(958)$	0	
$\eta_2(1645) \rightarrow f_2'(1525) \eta$	0	
$\eta_2(1645) \rightarrow f_2'(1525) \eta'(958)$	0	
$\eta_2(1870) \rightarrow \bar{K}^*(892) K + c.c.$	3.3	
$\eta_2(1870) \rightarrow a_2(1320) \pi$	221.0	
$\eta_2(1870) \rightarrow \bar{K}_2^*(1430) K + c.c.$	0	
$\eta_2(1870) \rightarrow f_2(1270) \eta$	9.4	
$\eta_2(1870) \rightarrow f_2(1270) \eta'(958)$	0	
$\eta_2(1870) \rightarrow f_2'(1525) \eta$	0	
$\eta_2(1870) \rightarrow f_2'(1525) \eta'(958)$	0	

Table 6: Decays of $I = 0$ pseudotensor states. The total decay widths are $\Gamma_{\eta_2(1645)}^{\text{tot}} = (181 \pm 11)$ MeV and $\Gamma_{\eta_2(1870)}^{\text{tot}} = (225 \pm 14)$ MeV.

ArXiv: 1608.08777

For a recent re-analysis with decay widths partial-wave :

V. Shastry, E. Trotti, F.G., Phys. Rev.D 105 (2022) 5, 054022 • e-Print: 2107.13501

Francesco Giacosa

Considerations

If new experimental data **confirms** our results,

- we have good candidates for a ground-state pseudotensor meson nonet.
- the large mixing angle $\beta_{pT} \approx -40^\circ$ would be a mystery which deserves a detailed study.
- the current phenomenological study should be redone, including higher order corrections.

If new experimental data **is at odd** with our results,

- an understanding of the lowlying pseudotensor states as a standard quark-antiquark nonet would be hard.
- $\eta_2(1870)$ could be wrongly assigned as a $\bar{q}q$ -state.
- possible further mixings with (hybrid) states could be included in the model.

Large mixing angle: where does it come from?



PHYSICAL REVIEW D **97**, 091901(R) (2018)

Rapid Communications

How the axial anomaly controls flavor mixing among mesons

Francesco Giacosa,^{1,2,*} Adrian Koenigstein,^{2,†} and Robert D. Pisarski^{3,‡}

¹*Institute of Physics, Jan Kochanowski University, ulica Swietokrzyska 15, 25-406 Kielce, Poland*

²*Institute for Theoretical Physics, Johann Wolfgang Goethe University, Max-von-Laue-Straße 1, 60438 Frankfurt am Main, Germany*

³*Department of Physics, Brookhaven National Laboratory, Upton, New York 11973, USA*

$$\begin{pmatrix} \eta_2(1645) \\ \eta_2(1870) \end{pmatrix} = \begin{pmatrix} \cos \beta_{pt} & \sin \beta_{pt} \\ -\sin \beta_{pt} & \cos \beta_{pt} \end{pmatrix} \begin{pmatrix} \eta_{2,N} \equiv \sqrt{\frac{1}{2}}(\bar{u}u + \bar{d}d) \\ \eta_{2,S} \equiv \bar{s}s \end{pmatrix} \quad \beta_{pt} = -42^\circ$$

$$\begin{pmatrix} \eta \equiv \eta(547) \\ \eta' \equiv \eta(958) \end{pmatrix} = \begin{pmatrix} \cos \theta_P & \sin \theta_P \\ -\sin \theta_P & \cos \theta_P \end{pmatrix} \begin{pmatrix} \eta_N = \sqrt{1/2}(\bar{u}u + \bar{d}d) \\ \eta_S = \bar{s}s \end{pmatrix} \quad \theta_P \simeq -42^\circ$$

(Excited) vector mesons

$n^{2S+1}L_J$	J^{PC}	I=1 $u\bar{d}, d\bar{u}$ $\frac{d\bar{d}-u\bar{u}}{\sqrt{2}}$	I=1/2 $u\bar{s}, d\bar{s}$ $s\bar{d}, s\bar{u}$	I=0 $\approx \frac{u\bar{u}+d\bar{d}}{\sqrt{2}}$	I=0 $\approx s\bar{s}$	Meson names	Chiral Partners
1^1S_0	0^{-+}	π	K	$\eta(547)$	$\eta'(958)$	Pseudoscalar	$J = 0$
1^3P_0	0^{++}	$a_0(1450)$	$K_0^*(1430)$	$f_0(1370)$	$f_0(1500)/f_0(1710)$	Scalar	
1^3S_1	1^{--}	$\rho(770)$	$K^*(892)$	$\omega(782)$	$\phi(1020)$	Vector	$J = 1$
1^3P_1	1^{++}	$a_1(1260)$	K_{1A}	$f_1(1285)$	$f_1'(1420)$	Axial-vector	
1^1P_1	1^{+-}	$b_1(1235)$	K_{1B}	$h_1(1170)$	$h_1(1415)$	Pseudovector	$J = 1^*$
1^3D_1	1^{--}	$\rho(1700)$	$K^*(1680)$	$\omega(1650)$	$\phi(???)$	Excited-vector	
1^3P_2	2^{++}	$a_2(1320)$	$K_2^*(1430)$	$f_2(1270)$	$f_2'(1525)$	Tensor	$J = 2$
1^3D_2	2^{--}	$\rho_2(???)$	$K_2(1820)$	$\omega_2(???)$	$\phi_2(???)$	Axial-tensor	
1^1D_2	2^{-+}	$\pi_2(1670)$	$K_2(1770)$	$\eta_2(1645)$	$\eta_2(1870)$	Pseudotensor	
1^3D_3	3^{--}	$\rho_3(1690)$	$K_3^*(1780)$	$\omega_3(1670)$	$\phi_3(1850)$	$J = 3$ - Tensor	

Citation: R.L. Workman *et al.* (Particle Data Group), to be published (2022)



$\phi(2170)$

$$I^G(J^{PC}) = 0^-(1^{--})$$

See the review on "Spectroscopy of Light Meson Resonances."



$\phi(2170)$ MASS

<u>VALUE (MeV)</u>	<u>EVTS</u>	<u>DOCUMENT ID</u>	<u>TECN</u>	<u>COMMENT</u>
2162 ± 7	OUR AVERAGE	Error includes scale factor of 1.1.		

$\phi(2170)$ WIDTH

<u>VALUE (MeV)</u>	<u>EVTS</u>	<u>DOCUMENT ID</u>	<u>TECN</u>	<u>C</u>
100 $\begin{smallmatrix} +31 \\ -23 \end{smallmatrix}$	OUR AVERAGE	Error includes scale factor of 2.5.		

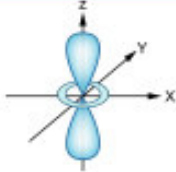
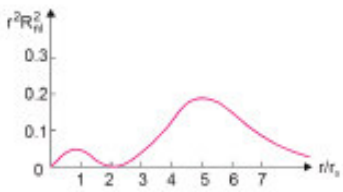
Excited vector mesons: properties

Type of excitation	Radially excited vector mesons	Angular momentum excited vector mesons
Quantum numbers	$n \ 2^{S+1}L_J = 2^3S_1$	$n \ 2^{S+1}L_J = 1^3D_1$
Notation	V_E	V_D
S	1 $\uparrow\uparrow$	1 $\uparrow\uparrow$
n	2	1
L	0	2
orbital		
Radial function		
Associated states	$\rho(1450), K^*(1410), \phi(1680), \omega(1420)$	$\rho(1700), K^*(1680), \phi_P, \omega(1650)$
Decay types	$V_E \rightarrow PP$ $V_E \rightarrow VP$ $V_E \rightarrow \gamma P$	$V_D \rightarrow PP$ $V_D \rightarrow VP$ $V_D \rightarrow \gamma P$

Radially excited vector mesons: some results



TABLE X. Decays widths of (predominantly) orbitally excited vector mesons into a pseudoscalar meson and a ground-state vector meson ($V_D \rightarrow VP$).

Decay process $V_D \rightarrow VP$	Theory (MeV)	Experiment (MeV)
$\rho(1700) \rightarrow \omega\pi$	140 ± 59	Seen (see text)
$\rho(1700) \rightarrow K^*(892)K$	56 ± 23	83 ± 66 MeV (see text)
$\rho(1700) \rightarrow \rho\eta$	41 ± 17	68 ± 42 MeV (see text)
$\rho(1700) \rightarrow \rho\eta'$	≈ 0	Not listed in PDG
$K^*(1680) \rightarrow K\rho$	64 ± 27	101 ± 35 by PDG
$K^*(1680) \rightarrow K\phi$	13 ± 6	Not listed in PDG
$K^*(1680) \rightarrow K\omega$	21 ± 9	Not listed in PDG
$K^*(1680) \rightarrow K^*(892)\pi$	81 ± 34	96 ± 33 by PDG
$K^*(1680) \rightarrow K^*(892)\eta$	0.5 ± 0.2	Not listed in PDG
$K^*(1680) \rightarrow K^*(892)\eta'$	≈ 0	Not listed in PDG
$\omega(1650) \rightarrow \rho\pi$	370 ± 156	$\sim 205, 154 \pm 44, \sim 273, 120 \pm 18$ (see text)
$\omega(1650) \rightarrow K^*(892)K$	42 ± 18	Not listed in PDG
$\omega(1650) \rightarrow \omega(782)\eta$	32 ± 13	$\sim 100, 56 \pm 30$ (see text)
$\omega(1650) \rightarrow \omega(782)\eta'$	≈ 0	Not listed in PDG
$\phi(1930) \rightarrow K\bar{K}^*$	260 ± 109	Resonance not yet known
$\phi(1930) \rightarrow \phi(1020)\eta$	67 ± 28	Resonance not yet known
$\phi(1930) \rightarrow \phi(1020)\eta'$	≈ 0	Resonance not yet known

Prediction for $\phi(1930)$

Can one find this state?

TABLE XII. Summary table for the putative state $\phi(1930)$.

Meson $\phi(1930)$	
Quark composition	$\approx s\bar{s}$
Old spectroscopy notation	(Predom.) $n^{2S+1}L_J = 1^3D_1$
n	(Predom.) 1
S	(Predom.) $1\uparrow\uparrow$
L	(Predom.) 2
J^{PC}	1^{--}
Mass	$\approx 1930 \pm 40$ MeV
Decays	
Decay channel	Decay width (MeV)
$\phi(1930) \rightarrow \bar{K}K$	104 ± 28
$\phi(1930) \rightarrow K\bar{K}^*$	260 ± 109
$\phi(1930) \rightarrow \Phi(1020)\eta$	67 ± 28
$\phi(1930) \rightarrow \Phi(1020)\eta'$	≈ 0
$\phi(1930) \rightarrow \gamma\eta$	0.19 ± 0.12
$\phi(1930) \rightarrow \gamma\eta'$	0.13 ± 0.08

arXiv: 1708.02593; **it does not fit with $\phi(2170)$**

Toward a nonet of hybrid state/PDG

$\pi_1(1600)$

$$I^{G(J^{PC})} = 1^-(1^{-+})$$

See the review on "Spectroscopy of Light Meson Resonances" and a note in PDG 06, Journal of Physics **G33** 1 (2006).

$\pi_1(1600)$ T-Matrix Pole \sqrt{s}

$\pi_1(1600)$ MASS

VALUE (MeV)	EVTS	DOCUMENT ID	TECN	COMMENT
1661⁺¹⁵₋₁₁ OUR AVERAGE				Error includes scale factor of 1.2.

$\pi_1(1600)$ WIDTH

VALUE (MeV)	EVTS	DOCUMENT ID	TECN	COMMENT
240\pm50 OUR AVERAGE				Error includes scale factor of 1.7. See the ideogram below.

$\pi_1(1600)$ DECAY MODES

	Mode	Fraction (Γ_i/Γ)
Γ_1	$\pi \pi \pi$	seen
Γ_2	$\rho^0 \pi^-$	seen
Γ_3	$f_2(1270) \pi^-$	not seen
Γ_4	$b_1(1235) \pi$	seen
Γ_5	$\eta'(958) \pi^-$	seen
Γ_6	$\eta \pi$	
Γ_7	$f_1(1285) \pi$	seen

$\pi_1(1400)$

$$I^{G(J^{PC})} = 1^-(1^{-+})$$

$\pi_1(1400)$ MASS

VALUE (MeV)	EVTS	DOCUMENT ID	TECN	CHG	COMMENT
1354\pm25 OUR AVERAGE					Error includes scale factor of 1.8. See the ideogram below.

$\pi_1(1400)$ WIDTH

VALUE (MeV)	EVTS	DOCUMENT ID	TECN	CHG	COMMENT
330\pm35 OUR AVERAGE					

$\pi_1(1400)$ DECAY MODES

	Mode	Fraction (Γ_i/Γ)
Γ_1	$\eta \pi^0$	seen
Γ_2	$\eta \pi^-$	seen

A unique $I=1$ hybrid state



PHYSICAL REVIEW LETTERS 122, 042002 (2019)

Determination of the Pole Position of the Lightest Hybrid Meson Candidate

A. Rodas,^{1,*} A. Pilloni,^{2,3,†} M. Albaladejo,^{2,4} C. Fernández-Ramírez,⁵ A. Jackura,^{6,7} V. Mathieu,²
M. Mikhasenko,⁸ J. Nys,⁹ V. Pauk,¹⁰ B. Ketzer,⁸ and A. P. Szczepaniak^{2,6,7}

Mapping states with explicit gluonic degrees of freedom in the light sector is a challenge, and has led to controversies in the past. In particular, the experiments have reported two different hybrid candidates with spin-exotic signature, $\pi_1(1400)$ and $\pi_1(1600)$, which couple separately to $\eta\pi$ and $\eta'\pi$. This picture is not compatible with recent Lattice QCD estimates for hybrid states, nor with most phenomenological models. We consider the recent partial wave analysis of the $\eta^{(\prime)}\pi$ system by the COMPASS Collaboration. We fit the extracted intensities and phases with a coupled-channel amplitude that enforces the unitarity and analyticity of the S matrix. We provide a robust extraction of a single exotic π_1 resonant pole, with mass and width $1564 \pm 24 \pm 86$ and $492 \pm 54 \pm 102$ MeV, which couples to both $\eta^{(\prime)}\pi$ channels. We find no evidence for a second exotic state. We also provide the resonance parameters of the $a_2(1320)$ and $a_2'(1700)$.

$\pi_1(1600)$ and $\pi_1(1400)$ are the same state
(in agreement with various models and lattice QCD)

C. Meyer and E. Swanson,
Hybrid Mesons,
Prog. Part. Nucl. Phys. 82 (2015) 21
[arXiv:1502.07276 [hep-ph]].

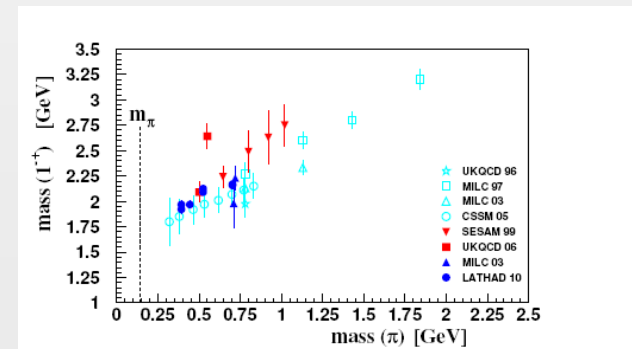

New experimental finding: $\eta(1855)$

Observation of an isoscalar resonance with exotic $J^{PC} = 1^{-+}$ quantum numbers in $J/\psi \rightarrow \gamma\eta\eta'$

M. Ablikim¹, M. N. Achasov^{10,b}, P. Adlarson⁶⁸, S. Ahmed¹⁴, M. Albrecht⁴, R. Aliberti²⁸, A. Amoroso^{67A,67C}, M. R. An³²,

Using a sample of $(10.09 \pm 0.04) \times 10^9$ J/ψ events collected with the BESIII detector operating at the BEPCII storage ring, a partial wave analysis of the decay $J/\psi \rightarrow \gamma\eta\eta'$ is performed. The first observation of an isoscalar state with exotic quantum numbers $J^{PC} = 1^{-+}$, denoted as $\eta_1(1855)$, is reported in the process $J/\psi \rightarrow \gamma\eta_1(1855) \rightarrow \gamma\eta\eta'$. Its mass and width are measured to be $(1855 \pm 9_{-1}^{+6})$ MeV/ c^2 and $(188 \pm 18_{-8}^{+3})$ MeV, respectively, where the first uncertainties are statistical and the second are systematic, and its statistical significance is estimated to be larger than 19σ .

arXiv: 2022.0062

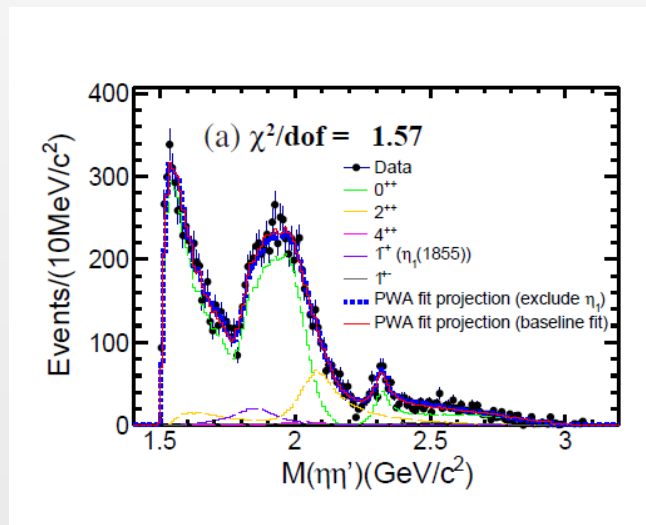

A nonet of hybrid states?

Physics Letters B 834 (2022) 137478



Contents lists available at ScienceDirect

Physics Letters B

www.elsevier.com/locate/physletb



The phenomenology of the exotic hybrid nonet with $\pi_1(1600)$ and $\eta_1(1855)$



Vanamali Shastry^{a,*}, Christian S. Fischer^{b,c}, Francesco Giacosa^{a,d}

arXiv:2203.04327

Beides $\pi_1(1600)$ and $\eta_1(1855)$, we expect also: $K_1(1750)$ and $\eta_1(1660)$. The last two not yet seen.

	M (MeV)	Γ (MeV)
K_1^{hyb}	1761	312 ± 97 170 ± 65
η_1^L	1661	81 ± 15 83 ± 16
η_1^H	1855	259 ± 92 157 ± 68



Table 7

The partial widths and branching ratios of various decay channels and the total width for the hybrid kaon $K_1^{hyb}(1750)$. We have assumed the mass of the state to be 1761 MeV [44].

Channel	Width (MeV)		Channel	Width (MeV)	
	Set-1	Set-2		Set-1	Set-2
$\Gamma_{K_1(1270)\pi}$	125 ± 42	48 ± 25	$\Gamma_{\rho K}$	2.18 ± 0.56	2.19 ± 0.57
$\Gamma_{K_1(1400)\pi}$	103 ± 45	98 ± 43	$\Gamma_{\omega K}$	0.82 ± 0.21	0.82 ± 0.21
$\Gamma_{h_1(1170)K}$	1.53 ± 0.28	1.37 ± 0.24	$\Gamma_{\phi K}$	0.49 ± 0.12	0.49 ± 0.13
$\Gamma_{\eta K}$	0.29 ± 0.07	0.29 ± 0.07	$\Gamma_{K^*\pi}$	0.67 ± 0.17	0.67 ± 0.17
$\Gamma_{\eta' K}$	2.77 ± 0.62	2.81 ± 0.62	$\Gamma_{K^*\eta}$	0.30 ± 0.08	0.30 ± 0.08
$\Gamma_{\rho K^*}$	0.045 ± 0.016	0.047 ± 0.016	$\Gamma_{\omega K^*}$	0.011 ± 0.004	0.012 ± 0.004
$\Gamma_{a_1 K}$	11.0 ± 2.32	11.3 ± 2.35	$\Gamma_{b_1 K}$	64 ± 14	3.11 ± 2.88
			Γ_{tot}	312 ± 97	170 ± 65

Table 6

The partial widths and branching ratios of various decay channels and the total width of the η_1^L (left) and the $\eta_1(1855)$ (right) for $\theta_h = 15^\circ$. This corresponds to the "Scenario-2" discussed in the text.

Channel	Width (MeV)		Channel	Width (MeV)	
	Set-1	Set-2		Set-1	Set-2
$\Gamma_{\rho_1 \pi}$	80 ± 15	82 ± 16	$\Gamma_{K_1(1270)K}$	253 ± 92	151 ± 67
Γ_{K^*K}	0.29 ± 0.075	0.29 ± 0.075	Γ_{K^*K}	1.45 ± 0.37	1.46 ± 0.38
$\Gamma_{\eta\eta}$	0.41 ± 0.09	0.41 ± 0.09	$\Gamma_{\eta\eta}$	2.28 ± 0.51	2.31 ± 0.51
$\Gamma_{K_1(1270)K}$	0	0	$\Gamma_{\rho_1 \pi}$	0	0
$\Gamma_{\rho\rho}$	0.081 ± 0.028	0.082 ± 0.029	$\Gamma_{\rho\rho}$	0	0
$\Gamma_{K^*K^*}$	0	0	$\Gamma_{K^*K^*}$	0.075 ± 0.027	0.077 ± 0.028
$\Gamma_{\omega\phi}$	0	0	$\Gamma_{\omega\phi}$	$\sim 10^{-4}$	$\sim 10^{-4}$
$\Gamma_{f_4\eta}$	0	0	$\Gamma_{f_4\eta}$	2.15 ± 0.56	2.21 ± 0.57
Γ_{tot}	81 ± 15	83 ± 16	Γ_{tot}	259 ± 92	157 ± 68

Dulcis in fundo: scalar sector

Eur. Phys. J. C (2022) 82:487
<https://doi.org/10.1140/epjc/s10052-022-10403-z>

THE EUROPEAN
PHYSICAL JOURNAL C



Regular Article - Theoretical Physics

Glueball–glueball scattering and the glueballonium

Francesco Giacosa^{1,2}, Alessandro Pilloni^{3,4}, Enrico Trotti^{1,a}

$$\mathcal{L}_{\text{dil}} = \frac{1}{2}(\partial_\mu G)^2 - V(G),$$

with

$$V(G) = \frac{1}{4} \frac{m_G^2}{\Lambda_G^2} \left(G^4 \ln \left| \frac{G}{\Lambda_G} \right| - \frac{G^4}{4} \right).$$

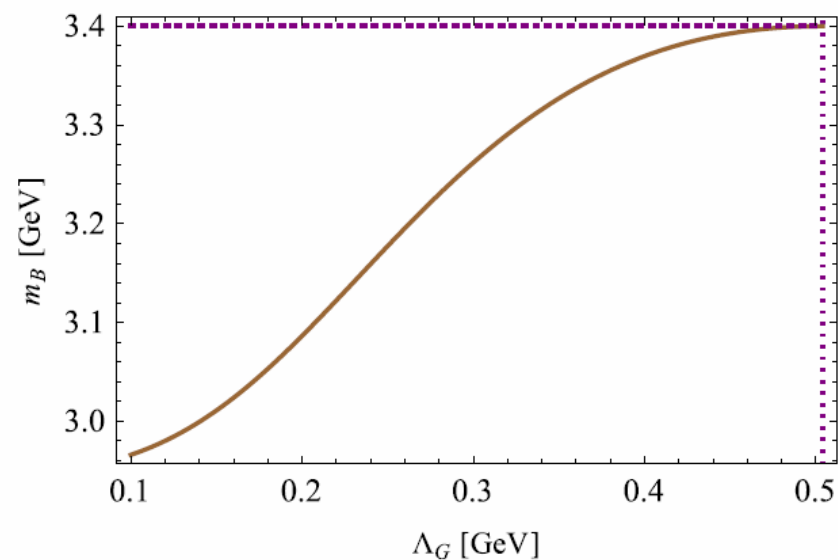

Conclusions and outlook



Many nonets fit well in the quark-antiquark picture, but...

- axial-tensor mesons basically unknown;
- pseudotensor mesons, is there a large isoscalar mixing?
- vector mesons: which is the orbitally excited ϕ meson?

Unconventional mesons:

- hybrid mesons: a new nonet?

Outlook:

- tensor glueball (ongoing)

Thanks

Back-up slides

Conventional mesons

Quark: u,d,s,... R,G,B

Quark-antiquark bound states: conventional mesons

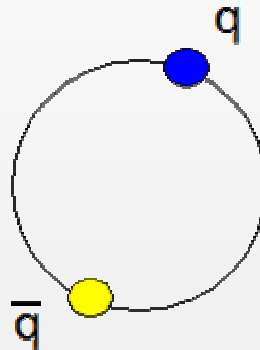

$$|color\rangle = \sqrt{1/3} (\bar{R}R + \bar{B}B + \bar{G}G)$$

Conventional mesons/2

Surely, with quark-antiquark states we can understand a lot of QCD, but definitely not everything.

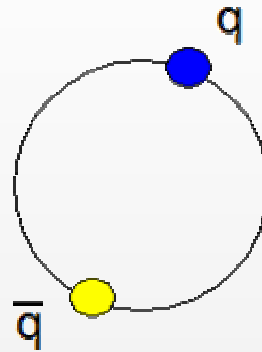

$$P = -(-1)^L \quad C = (-1)^{L+S}$$

$$L, S \quad \longrightarrow \quad J = L + S \quad J^{PC}$$

$L = S = 0 \rightarrow J^{PC} = 0^{-+}$ pseudoscalar mesons

$$|\pi^+\rangle = |u\bar{d}\rangle |\text{space} : L = 0\rangle |\text{spin} : S = 0\rangle |\bar{R}R + \bar{B}B + \bar{G}G\rangle$$



$$|K^+\rangle = |u\bar{s}\rangle |\text{space} : L = 0\rangle |\text{spin} : S = 0\rangle |\bar{R}R + \bar{B}B + \bar{G}G\rangle$$

...

$$|D^0\rangle = |u\bar{c}\rangle |\text{space} : L = 0\rangle |\text{spin} : S = 0\rangle |\bar{R}R + \bar{B}B + \bar{G}G\rangle$$

...

$L = 0, S = 1 \rightarrow J^{PC} = 1^{--}$ vector mesons

$$|\rho^+\rangle = |u\bar{d}\rangle |\text{space} : L = 0\rangle |\text{spin} : S = 1\rangle |\bar{R}R + \bar{B}B + \bar{G}G\rangle$$

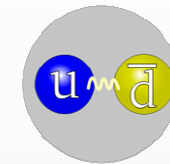

...

$$|K^*(892)^+\rangle = |u\bar{s}\rangle |\text{space} : L = 0\rangle |\text{spin} : S = 1\rangle |\bar{R}R + \bar{B}B + \bar{G}G\rangle$$

...

$$|D^{*0}\rangle = |u\bar{c}\rangle |\text{space} : L = 0\rangle |\text{spin} : S = 1\rangle |\bar{R}R + \bar{B}B + \bar{G}G\rangle$$

...

$$|j/\Psi\rangle = |c\bar{c}\rangle |\text{space} : L = 0\rangle |\text{spin} : S = 1\rangle |\bar{R}R + \bar{B}B + \bar{G}G\rangle$$

$L = S = 1 \rightarrow J^{PC} = 0^{++}$ scalar mesons

$$|\sigma\rangle = |u\bar{u} + d\bar{d}\rangle |space : L = 1\rangle |spin : S = 1\rangle |\bar{R}R + \bar{B}B + \bar{G}G\rangle$$

corresponds to the resonance $f_0(1370)$.

...

...

$$|\chi_{c0}(1S)\rangle = |c\bar{c}\rangle |space : L = 1\rangle |spin : S = 1\rangle |\bar{R}R + \bar{B}B + \bar{G}G\rangle$$

Quark model(s) and their QFT extensions



Mesons in a Relativized Quark Model with Chromodynamics

S. Godfrey, N. Isgur

Phys.Rev. D32 (1985) **189-231**

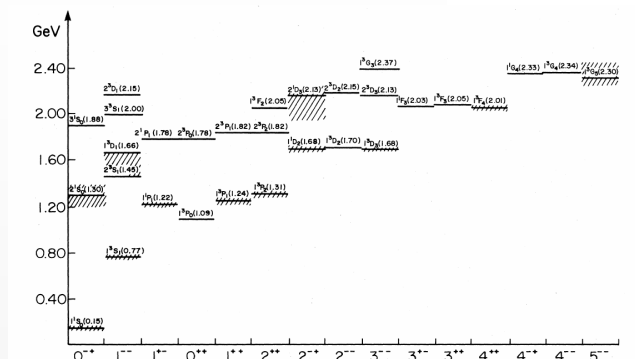

QCD phenomenology based on a chiral effective Lagrangian

T. Hatsuda, T. Kunihiro

Phys.Rept. **247** (1994) 221-367

NJL: quark-based model with chiral symmetry and SSB

chiral condensate

Effective quark mass

Mesons as quarkonia (pion: ok)

The Infrared behavior of QCD Green's functions: Confinement dynamical symmetry breaking, and hadrons as relativistic bound states

R. Alkofer, L. von Smekal

Phys.Rept. **353** (2001) 281

DS:

quarks and gluons propagators from QCD

Condensates

Effective quark and gluon masses

Spectra of mesons as quarkonia

(pion: ok) and baryons as qqq states

Baryons as relativistic three-quark bound states

G. Eichmann et al.

Progr. Part. Nucl. Phys. **91** (2016) 1

Quark-antiquark currents

Meson	$n^{2S+1}L_J$	J^{PC}	S	L	Hermitian quark current operators
pseudoscalar	1^1S_0	0^{-+}	0	0	$P_{ij} = \bar{q}_j i \gamma^5 q_i$
vector	1^3S_1	1^{--}	1		$V_{ij}^\mu = \bar{q}_j \gamma^\mu q_i$
pseudovector	1^1P_1	1^{+-}	0	1	$P_{ij}^\mu = \bar{q}_j \gamma^5 \overleftrightarrow{\partial}^\mu q_i$
scalar	1^3P_0	0^{++}	1		$S_{ij} = \bar{q}_j q_i$
axial vector	1^3P_1	1^{++}	1		$A_{ij}^\mu = \bar{q}_j \gamma^5 \gamma^\mu q_i$
tensor	1^3P_2	2^{++}	1		$X_{ij}^{\mu\nu} = \bar{q}_j i \left[\gamma^\mu \overleftrightarrow{\partial}^\nu + \gamma^\nu \overleftrightarrow{\partial}^\mu - \frac{2}{3} \tilde{G}^{\mu\nu} \overleftrightarrow{\not{\partial}} \right] q_i$
pseudotensor	1^1D_2	2^{-+}	0	2	$T_{ij}^{\mu\nu} = \bar{q}_j i \left[\gamma^5 \overleftrightarrow{\partial}^\mu \overleftrightarrow{\partial}^\nu - \frac{2}{3} \tilde{G}^{\mu\nu} \overleftrightarrow{\partial}_\alpha \overleftrightarrow{\partial}^\alpha \right] q_i$
excited vector	1^3D_1	1^{--}	1		$S_{ij}^\mu = \bar{q}_j \overleftrightarrow{\partial}^\mu q_i$
axial tensor	1^3D_2	2^{--}	1		$B_{ij}^{\mu\nu} = \bar{q}_j i \left[\gamma^5 \gamma^\mu \overleftrightarrow{\partial}^\nu + \gamma^5 \gamma^\nu \overleftrightarrow{\partial}^\mu - \frac{2}{3} \tilde{G}^{\mu\nu} \gamma^5 \overleftrightarrow{\not{\partial}} \right] q_i$
spin-3 tensor	1^3D_3	3^{--}	1		...

The eLSM: a chiral model of QCD



PHYSICAL REVIEW D **87**, 014011 (2013)

Meson vacuum phenomenology in a three-flavor linear sigma model with (axial-)vector mesons

D. Parganlija,^{1,2,*} P. Kovács,^{2,3,†} Gy. Wolf,^{3,‡} F. Giacosa,^{2,§} and D. H. Rischke^{2,4,||}

¹*Institute for Theoretical Physics, Vienna University of Technology, Wiedner Hauptstrasse 8-10, A-1040 Vienna, Austria*

²*Institute for Theoretical Physics, Johann Wolfgang Goethe University, Max-von-Laue-Strasse 1, D-60438 Frankfurt am Main, Germany*

³*Institute for Particle and Nuclear Physics, Wigner Research Center for Physics,
Hungarian Academy of Sciences, H-1525 Budapest, Hungary*

⁴*Frankfurt Institute for Advanced Studies, Ruth-Moufang-Strasse 1, D-60438 Frankfurt am Main, Germany*

(Received 7 August 2012; published 8 January 2013)

PHYSICAL REVIEW D **90**, 114005 (2014)

Is $f_0(1710)$ a glueball?

Stanislaus Janowski,¹ Francesco Giacosa,^{1,2} and Dirk H. Rischke¹

¹*Institute for Theoretical Physics, Goethe University,
Max-von-Laue-Straße 1, 60438 Frankfurt am Main, Germany*

²*Institute of Physics, Jan Kochanowski University, 25-406 Kielce, Poland*

(Received 26 August 2014; published 2 December 2014)

Model of QCD – eLSM with scalar Glueball

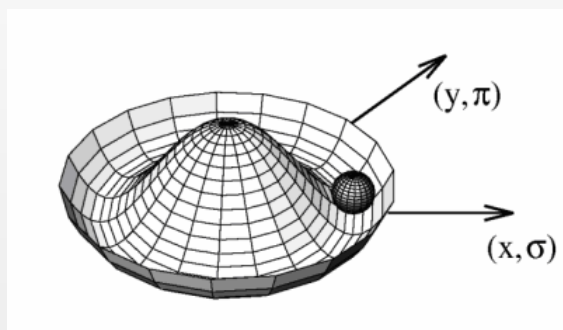
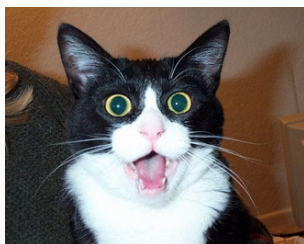

$$\begin{aligned} \mathcal{L} = & \frac{1}{2}(\partial_\mu G)^2 - \frac{1}{4} \frac{m_G^2}{\Lambda^2} \left(G^4 \ln \left| \frac{G}{\Lambda} \right| - \frac{G^4}{4} \right) + \text{Tr} [(D^\mu \Phi)^\dagger (D_\mu \Phi)] \\ & - m_0^2 \left(\frac{G}{G_0} \right)^2 \text{Tr} [\Phi^\dagger \Phi] - \lambda_1 (\text{Tr} [\Phi^\dagger \Phi])^2 - \lambda_2 \text{Tr} [(\Phi^\dagger \Phi)^2] \\ & + \left(\frac{G}{G_0} \right)^2 \text{Tr} \left[\left(\frac{m_1^2}{2} + \Delta \right) ((L^\mu)^2 + (R^\mu)^2) \right] \\ & - \frac{1}{4} \text{Tr} [(L^{\mu\nu})^2 + (R^{\mu\nu})^2] + \text{Tr} [H (\Phi^\dagger + \Phi)] \\ & + c_1 [\det(\Phi) - \det(\Phi^\dagger)]^2 + \frac{h_1}{2} \text{Tr}[\Phi^\dagger \Phi] \text{Tr}[L_\mu L^\mu + R_\mu R^\mu] \\ & + h_2 \text{Tr}[\Phi^\dagger L_\mu L^\mu \Phi + \Phi R_\mu R^\mu \Phi^\dagger] + 2h_3 \text{Tr}[\Phi R_\mu \Phi^\dagger L^\mu] \end{aligned}$$

$$\Phi = \frac{1}{\sqrt{2}} \begin{pmatrix} \frac{(\sigma_N + a_0^0) + i(\eta_N + \pi^0)}{\sqrt{2}} & a_0^+ + i\pi^+ & K_0^{*+} + iK^+ \\ a_0^- + i\pi^- & \frac{(\sigma_N - a_0^0) + i(\eta_N - \pi^0)}{\sqrt{2}} & K_0^{*0} + iK^0 \\ K_0^{*-} + iK^- & \bar{K}_0^{*0} + i\bar{K}^0 & \sigma_S + i\eta_S \end{pmatrix}$$

$$L^\mu, R^\mu = \frac{1}{\sqrt{2}} \begin{pmatrix} \frac{\omega_N \pm \rho^0}{\sqrt{2}} \pm \frac{f_{1N} \pm a_1^0}{\sqrt{2}} & \rho^+ \pm a_1^+ & K^{*+} \pm K_1^+ \\ \rho^- \pm a_1^- & \frac{\omega_N \mp \rho^0}{\sqrt{2}} \pm \frac{f_{1N} \mp a_1^0}{\sqrt{2}} & K^{*0} \pm K_1^0 \\ K^{*-} \pm K_1^- & \bar{K}^{*0} \pm i\bar{K}_1^0 & \omega_S \pm f_{1S} \end{pmatrix}$$

S. Janowski, D. Parganlija, F. Giacosa, D. H. Rischke, **Phys. Rev. D84, 054007 (2011)**
D. Parganlija, P. Kovacs, G. Wolf, F. Giacosa, D. H. Rischke, **Phys.Rev. D87 (2013) 014011**

Results of the eLSM (11 parameters, 21 exp. quantities)

Error from PDG or 5% of exp.
Scalar-isoscalar sector not
included.

$$\chi_{red}^2 = 1.2$$

Observable	Fit [MeV]	Experiment [MeV]
f_π	96.3 ± 0.7	92.2 ± 4.6
f_K	106.9 ± 0.6	110.4 ± 5.5
m_π	141.0 ± 5.8	137.3 ± 6.9
m_K	485.6 ± 3.0	495.6 ± 24.8
m_η	509.4 ± 3.0	547.9 ± 27.4
$m_{\eta'}$	962.5 ± 5.6	957.8 ± 47.9
m_ρ	783.1 ± 7.0	775.5 ± 38.8
m_{K^*}	885.1 ± 6.3	893.8 ± 44.7
m_ϕ	975.1 ± 6.4	1019.5 ± 51.0
m_{a_1}	1186 ± 6	1230 ± 62
$m_{f_1(1420)}$	1372.5 ± 5.3	1426.4 ± 71.3
m_{a_0}	1363 ± 1	1474 ± 74
$m_{K_0^*}$	1450 ± 1	1425 ± 71
$\Gamma_{\rho \rightarrow \pi\pi}$	160.9 ± 4.4	149.1 ± 7.4
$\Gamma_{K^* \rightarrow K\pi}$	44.6 ± 1.9	46.2 ± 2.3
$\Gamma_{\phi \rightarrow \bar{K}K}$	3.34 ± 0.14	3.54 ± 0.18
$\Gamma_{a_1 \rightarrow \rho\pi}$	549 ± 43	425 ± 175
$\Gamma_{a_1 \rightarrow \pi\gamma}$	0.66 ± 0.01	0.64 ± 0.25
$\Gamma_{f_1(1420) \rightarrow K^*K}$	44.6 ± 39.9	43.9 ± 2.2
Γ_{a_0}	266 ± 12	265 ± 13
$\Gamma_{K_0^* \rightarrow K\pi}$	285 ± 12	270 ± 80

arXiv:1208.0585

Pseudotensor: Lagrangians and decays

Pseudotensor mesons: $\{\pi_2(1670), K_2(1770), \eta_2(1645), \eta_2(1870)\}$
Lagrangians based on flavour symmetry

$$\mathcal{L}_{TVP} = c_{TVP} \text{Tr} \{ T_{\mu\nu} [V^\mu, (\partial^\nu P)]_- \},$$

$$P = \begin{pmatrix} \frac{\eta_N + \pi^0}{\sqrt{2}} & \pi^+ & K^+ \\ \pi^- & \frac{\eta_N - \pi^0}{\sqrt{2}} & K^0 \\ K^- & \bar{K}^0 & \eta_S \end{pmatrix}, \quad V^\mu = \begin{pmatrix} \frac{\omega_N^\mu + \rho^{0\mu}}{\sqrt{2}} & \rho^{+\mu} & K^{*+\mu} \\ \rho^{-\mu} & \frac{\omega_N^\mu - \rho^{0\mu}}{\sqrt{2}} & K^{*0\mu} \\ K^{*-\mu} & \bar{K}^{*0\mu} & \omega_S^\mu \end{pmatrix},$$

$$T^{\mu\nu} = \begin{pmatrix} \frac{\eta_{2,N}^{\mu\nu} + \pi_2^{0\mu\nu}}{\sqrt{2}} & \pi_2^{+\mu\nu} & K_2^{+\mu\nu} \\ \pi_2^{-\mu\nu} & \frac{\eta_{2,N}^{\mu\nu} - \pi_2^{0\mu\nu}}{\sqrt{2}} & K_2^{0\mu\nu} \\ K_2^{-\mu\nu} & \bar{K}_2^{0\mu\nu} & \eta_{2,S}^{\mu\nu} \end{pmatrix}.$$

$$\mathcal{L}_{TXP} = c_{TXP} \text{Tr} (T_{\mu\nu} \{X^{\mu\nu}, P\}_+)$$

$$P = \begin{pmatrix} \frac{\eta_N + \pi^0}{\sqrt{2}} & \pi^+ & K^+ \\ \pi^- & \frac{\eta_N - \pi^0}{\sqrt{2}} & K^0 \\ K^- & \bar{K}^0 & \eta_S \end{pmatrix}, \quad X^{\mu\nu} = \begin{pmatrix} \frac{f_{2,N}^{\mu\nu} + a_2^{0\mu\nu}}{\sqrt{2}} & a_2^{+\mu\nu} & K_2^{*+\mu\nu} \\ a_2^{-\mu\nu} & \frac{f_{2,N}^{\mu\nu} - a_2^{0\mu\nu}}{\sqrt{2}} & K_2^{*0\mu\nu} \\ K_2^{*-\mu\nu} & \bar{K}_2^{*0\mu\nu} & f_{2,S}^{\mu\nu} \end{pmatrix},$$

$$T^{\mu\nu} = \begin{pmatrix} \frac{\eta_{2,N}^{\mu\nu} + \pi_2^{0\mu\nu}}{\sqrt{2}} & \pi_2^{+\mu\nu} & K_2^{+\mu\nu} \\ \pi_2^{-\mu\nu} & \frac{\eta_{2,N}^{\mu\nu} - \pi_2^{0\mu\nu}}{\sqrt{2}} & K_2^{0\mu\nu} \\ K_2^{-\mu\nu} & \bar{K}_2^{0\mu\nu} & \eta_{2,S}^{\mu\nu} \end{pmatrix}.$$

Tree-level decay widths:

$$\Gamma_{T \rightarrow VP}^{tl} = \frac{k_f}{8\pi m_T} \frac{g_{TVP}^2}{15} \left(2 \frac{k_f^4}{m_V^4} + 5 k_f^2 \right) \Theta(m_T - m_V - m_P),$$

and

$$\Gamma_{T \rightarrow XP}^{tl} = \frac{k_f}{8\pi m_T} \frac{g_{TXP}^2}{45} \left(4 \frac{k_f^4}{m_X^4} + 30 \frac{k_f^2}{m_X^2} + 45 \right) \Theta(m_T - m_X - m_P).$$

Large mixing angle: where does it come from?

Such a mixing is suppressed...

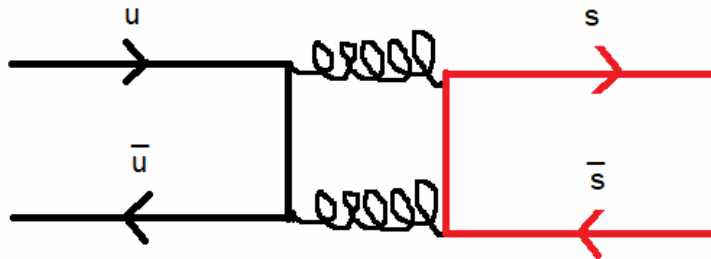

But this can be large

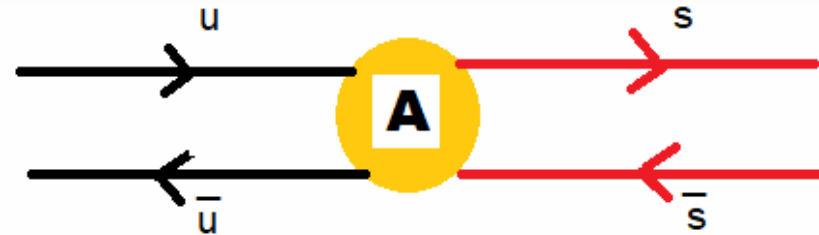

- For pseudoscalar mesons: $\eta(547)$ and $\eta'(958)$. $\Theta_{\text{mix}} = -42^\circ$ Large mixing caused by the axial anomaly.
- For vector mesons: $\omega(782)$ and $\phi(1020)$. $\Theta_{\text{mix}} = -3^\circ$ Very small mixing.
- For tensor mesons: $f_2(1270)$ and $f_2'(1525)$. $\Theta_{\text{mix}} = 3^\circ$ Also very small mixing. Why?
- Pseudotensor mesons: also large, but confirmation is needed.

Details in: **1709.07454**

Excited vectors: Lagrangians

The Lagrangian of the model is:

$$\mathcal{L} = \mathcal{L}_{1,E} + \mathcal{L}_{1,D} + \mathcal{L}_{2,E} + \mathcal{L}_{2,D},$$

where:

$$\mathcal{L}_{1,E} = ia_E \text{Tr}[\partial^\mu P, V_{E,\mu}]P \quad \mathcal{L}_{1,D} = ia_D \text{Tr}[\partial^\mu P, V_{D,\mu}]P$$

$$\mathcal{L}_{2,E} = b_E \text{Tr}[\tilde{V}_E^{\mu\nu} \{V_{\mu\nu}, P\}] \quad \mathcal{L}_{2,D} = b_D \text{Tr}[\tilde{V}_D^{\mu\nu} \{V_{\mu\nu}, P\}]$$

a_E, a_D, b_E, b_D – coupling constants of the different decay types.

- $R \rightarrow \gamma P$ through „vector meson dominance”

$$V_{\mu\nu} \rightarrow V_{\mu\nu} + \frac{e_0}{g_\rho} Q F_{\mu\nu}$$

$F_{\mu\nu}$ – field strength tensor for photons

$$e_0 = \sqrt{4\pi\alpha} \quad \alpha \approx 1/137 \quad g_\rho \approx 5.5 \pm 0.5 \quad Q = \text{diag}(\frac{2}{3}, -\frac{1}{3}, -\frac{1}{3})$$

Strong and radiative decay widths

TYPE OF DECAY

- $R \rightarrow PP$

$$\Gamma_{R \rightarrow PP} = S \frac{|\vec{k}|^3}{6\pi m_R^2} \left[\frac{a_i}{2} \lambda_{RPP} \right]^2$$

- $R \rightarrow VP, R \rightarrow \gamma P$

$$\Gamma_{R \rightarrow VP} = S \frac{|\vec{k}|^3}{12\pi} \left[\frac{b_i}{2} \lambda_{RVP} \right]^2$$

EXAMPLES

- $K^*(1410) \rightarrow K\eta$

$$\Gamma_{K^*(1410) \rightarrow K\eta} = \frac{|\vec{k}|^3}{6\pi m_{K^*(1410)}^2} \left[\frac{a_E}{2} \frac{1}{2} (\cos\theta_p - \sqrt{2}\sin\theta_p) \right]^2$$

- $\phi(1680) \rightarrow \phi(1020)\eta$

$$\Gamma_{\phi(1680) \rightarrow \phi(1020)\eta} = \frac{|\vec{k}|^3}{12\pi} \left[\frac{b_E}{2} \frac{\sin\theta_p}{\sqrt{2}} \right]^2$$

where:

$$|\vec{k}| = \frac{\sqrt{m_R^2 + (m_a^2 - m_b^2)^2 - 2(m_a^2 + m_b^2)m_R^2}}{2m_R};$$

m_R – mass of the decaying resonance;
 a_i, b_i – coupling constants ($i = E, D$);

m_a, m_b – masses of decay products;
 S – symmetry factor;

Matrices of fields

$$P = \begin{pmatrix} \frac{1}{\sqrt{2}} \frac{\eta_{N^+} + \pi^0}{\sqrt{2}} & \pi^+ & K^+ \\ \pi^- & \frac{\eta_{N^-} - \pi^0}{\sqrt{2}} & K^0 \\ K^- & K^0 & \eta_S \end{pmatrix}$$

$$V^\mu = \frac{1}{\sqrt{2}} \begin{pmatrix} \frac{\omega^\mu + \rho^{\mu 0}}{\sqrt{2}} & \rho^{\mu+} & K_i^{\mu*+} \\ \rho^{\mu-} & \frac{\omega^\mu - \rho^{\mu 0}}{\sqrt{2}} & K^{\mu*0} \\ K^{\mu*-} & K^{\mu*0} & \phi^\mu \end{pmatrix}$$

$$V_E^\mu = \frac{1}{\sqrt{2}} \begin{pmatrix} \frac{\omega_E^\mu + \rho_E^{\mu 0}}{\sqrt{2}} & \rho_E^{\mu+} & K_E^{\mu*+} \\ \rho_E^{\mu-} & \frac{\omega_E^\mu - \rho_E^{\mu 0}}{\sqrt{2}} & K_E^{\mu*0} \\ K_E^{\mu*-} & K_E^{\mu*0} & \phi_E^\mu \end{pmatrix}$$

$$V_D^\mu = \frac{1}{\sqrt{2}} \begin{pmatrix} \frac{\omega_D^\mu + \rho_D^{\mu 0}}{\sqrt{2}} & \rho_D^{\mu+} & K_D^{\mu*+} \\ \rho_D^{\mu-} & \frac{\omega_D^\mu - \rho_D^{\mu 0}}{\sqrt{2}} & K_D^{\mu*0} \\ K_D^{\mu*-} & K_D^{\mu*0} & \phi_D^\mu \end{pmatrix}$$

- $P = \{\pi, K, \eta, \eta'\}$
- $V = \{\rho(770), K^*(892), \phi(1020), \omega(782)\}$
- $V_E = \{\rho(1450), K^*(1410), \phi(1680), \omega(1420)\}$
- $V_D = \{\rho(1700), K^*(1680), \phi_p, \omega(1650)\}$

Which mass for the missing state?

TABLE I. Mass differences between the members of the two nonets of excited vector mesons.

V_E	$\rho(1450)$	$K^*(1410)$	$\omega(1420)$	$\phi(1680)$
V_D	$\rho(1700)$	$K^*(1680)$	$\omega(1650)$	$\phi(???)$
Difference	250 MeV	270 MeV	230 MeV	?

Hence, we can estimate the mass of $\phi(???)$ as

$$m_{\phi(???) } \simeq (m_{\phi(1680)} + 250 \pm 20) \text{ MeV} = 1930 \pm 20 \text{ MeV}.$$

From now on we shall call this hypothetical state

$$\phi(???) \equiv \phi(1930).$$