

Short-BaseLine Electron Neutrino Disappearance

Carlo Giunti

INFN, Sezione di Torino, and
Dipartimento di Fisica Teorica, Università di Torino

<mailto://giunti@to.infn.it>

Neutrino Unbound: <http://www.nu.to.infn.it>

29 April 2010

GDR neutrino a l'X, École Polytechnique, Palaiseau, France

work in collaboration with

Marco Laveder (Padova Univ.) Walter Winter (Würzburg Univ.)

Standard Model: Massless Neutrinos

- ▶ Standard Model: $\nu_L, \nu_R^c \implies$ no Dirac mass term $\mathcal{L}^D \sim m^D \nu_L \nu_R$
- ▶ Majorana Neutrino: $\nu^c = \nu$
- ▶ $\nu_R^c = \nu_R \implies$ Majorana mass term $\mathcal{L}^M \sim m^M \nu_L \nu_R^c$
- ▶ Standard Model: Majorana mass term **not** allowed by $SU(2)_L \times U(1)_Y$
(no Higgs triplet)

- ▶ Neutrinos are special in the Standard Model: the only **neutral fermions**
- ▶ In extensions of the SM neutrinos can mix with non-SM fermions:

$$L_L = \begin{pmatrix} \nu_{eL} \\ e_L \end{pmatrix} \begin{pmatrix} I=1/2 \\ Y=-1 \end{pmatrix} \quad \Phi = \begin{pmatrix} \phi^+ \\ \phi^0 \end{pmatrix} \begin{pmatrix} I=1/2 \\ Y=+1 \end{pmatrix} \quad \tilde{\Phi} = i\tau_2 \Phi^* \begin{pmatrix} I=1/2 \\ Y=-1 \end{pmatrix}$$

non-SM chiral fermion field $f_R = f_L^C \begin{pmatrix} I=0 \\ Y=0 \end{pmatrix}$

Dirac mass term $\sim \overline{L}_L \tilde{\Phi} f_R$ + Majorana mass term $\sim \overline{f_R^C} f_R$
 in some models f_R is called **right-handed neutrino**: $f_R \rightarrow \nu_R$

- ▶ If these non-SM fermions are light, they are called **sterile neutrinos**:

$$\nu_{sL} \equiv \nu_R^C$$

- ▶ Active neutrinos (ν_e, ν_μ, ν_τ) can oscillate into sterile neutrinos (ν_s)
- ▶ Extremely interesting window on physics beyond the SM
- ▶ Observable: **disappearance** of active neutrinos
- ▶ Many $\nu_e^{(-)}$ and $\nu_\mu^{(-)}$ disappearance experiments
- ▶ We focus on ν_e and $\bar{\nu}_e$ disappearance
- ▶ Gallium and MiniBooNE ν_e anomalies and reactor $\bar{\nu}_e$ data

Experimental Evidences of Neutrino Oscillations

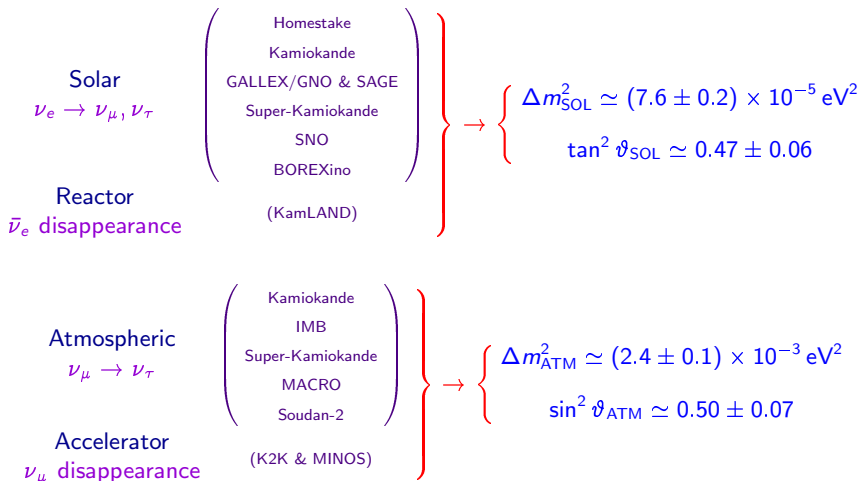

Two scales of Δm^2 : $\Delta m_{\text{ATM}}^2 \simeq 30 \Delta m_{\text{SOL}}^2$

Large mixings: $\vartheta_{\text{ATM}} \simeq 45^\circ$, $\vartheta_{\text{SOL}} \simeq 34^\circ$

Three-Neutrino Mixing

$$\nu_{\alpha L} = \sum_{k=1}^3 U_{\alpha k} \nu_{kL} \quad (\alpha = e, \mu, \tau)$$

three flavor fields: ν_e, ν_μ, ν_τ

three massive fields: ν_1, ν_2, ν_3

$$\Delta m_{21}^2 + \Delta m_{32}^2 + \Delta m_{13}^2 = m_2^2 - m_1^2 + m_3^2 - m_2^2 + m_1^2 - m_3^2 = 0$$

$$\Delta m_{\text{SOL}}^2 = \Delta m_{21}^2 \simeq (7.6 \pm 0.2) \times 10^{-5} \text{ eV}^2$$

$$\Delta m_{\text{ATM}}^2 \simeq |\Delta m_{31}^2| \simeq |\Delta m_{32}^2| \simeq (2.4 \pm 0.1) \times 10^{-3} \text{ eV}^2$$

Allowed Three-Neutrino Schemes

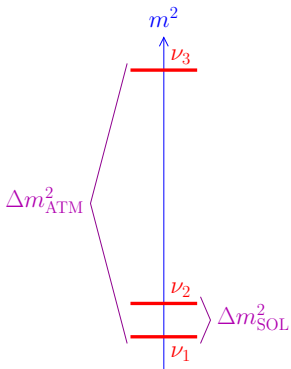

"normal"

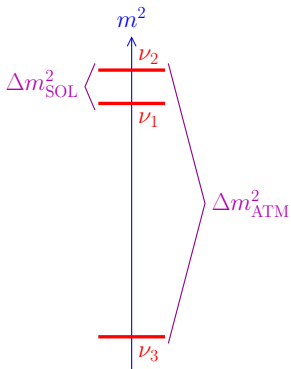

"inverted"

different signs of $\Delta m_{31}^2 \simeq \Delta m_{32}^2$

absolute scale is not determined by neutrino oscillation data

Gallium Anomaly

Gallium Radioactive Source Experiments

Tests of the solar neutrino detectors **GALLEX** (Cr1, Cr2) and **SAGE** (Cr, Ar)

Detection Process: $\nu_e + {}^{71}\text{Ga} \rightarrow {}^{71}\text{Ge} + e^-$

ν_e Sources: $e^- + {}^{51}\text{Cr} \rightarrow {}^{51}\text{V} + \nu_e$ $e^- + {}^{37}\text{Ar} \rightarrow {}^{37}\text{Cl} + \nu_e$

	${}^{51}\text{Cr}$				${}^{37}\text{Ar}$	
E [keV]	747	752	427	432	811	813
B.R.	0.8163	0.0849	0.0895	0.0093	0.902	0.098

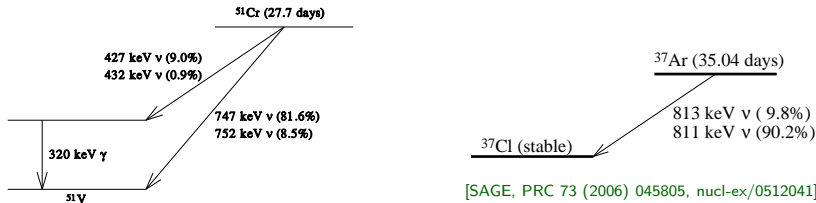

[SAGE, PRC 73 (2006) 045805, nucl-ex/0512041]

[SAGE, PRC 59 (1999) 2246, hep-ph/9803418]

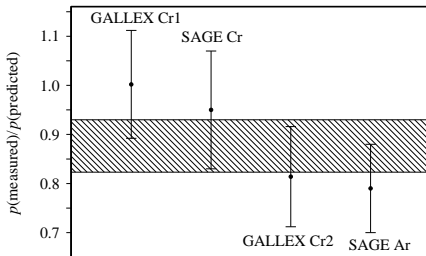
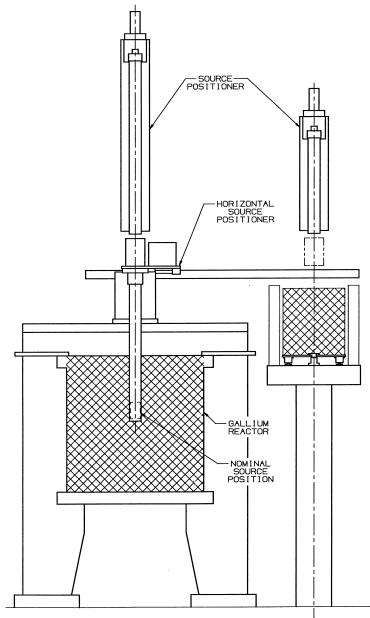

[SAGE, PRC 73 (2006) 045805, nucl-ex/0512041]

$$R_{\text{Ga}} = 0.88 \pm 0.05$$

[SAGE, PRC 59 (1999) 2246, hep-ph/9803418]

- ▶ Deficit could be due to overestimate of $\sigma(\nu_e + {}^{71}\text{Ga} \rightarrow {}^{71}\text{Ge} + e^-)$
- ▶ Calculation: Bahcall, PRC 56 (1997) 3391, hep-ph/9710491

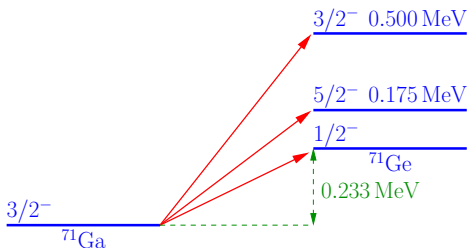

- ▶ $\sigma_{\text{G.S.}}$ related to measured $\sigma(e^- + {}^{71}\text{Ge} \rightarrow {}^{71}\text{Ga} + \nu_e)$:

$$\sigma_{\text{G.S.}}({}^{51}\text{Cr}) = 55.3 \times 10^{-46} \text{ cm}^2 (1 \pm 0.004)_{3\sigma}$$

- ▶ $\sigma({}^{51}\text{Cr}) = \sigma_{\text{G.S.}}({}^{51}\text{Cr}) \left(1 + 0.669 \frac{\text{BGT}_{175 \text{ keV}}}{\text{BGT}_{\text{G.S.}}} + 0.220 \frac{\text{BGT}_{500 \text{ keV}}}{\text{BGT}_{\text{G.S.}}} \right)$

► Bahcall:

[Bahcall, PRC 56 (1997) 3391, hep-ph/9710491]

from $p + {}^{71}\text{Ge} \rightarrow {}^{71}\text{Ge} + n$ measurements [Krofccheck et al., PRL 55 (1985) 1051]

$$\frac{\text{BGT}_{175\text{ keV}}}{\text{BGT}_{\text{G.S.}}} < 0.056 \Rightarrow \frac{\text{BGT}_{175\text{ keV}}}{\text{BGT}_{\text{G.S.}}} = \frac{0.056}{2} \quad \frac{\text{BGT}_{500\text{ keV}}}{\text{BGT}_{\text{G.S.}}} = 0.146$$

$$3\sigma \text{ lower limit: } \frac{\text{BGT}_{175\text{ keV}}}{\text{BGT}_{\text{G.S.}}} = \frac{\text{BGT}_{500\text{ keV}}}{\text{BGT}_{\text{G.S.}}} = 0$$

$$3\sigma \text{ upper limit: } \frac{\text{BGT}_{175\text{ keV}}}{\text{BGT}_{\text{G.S.}}} < 0.056 \times 2 \quad \frac{\text{BGT}_{500\text{ keV}}}{\text{BGT}_{\text{G.S.}}} = 0.146 \times 2$$

$$\sigma({}^{51}\text{Cr}) = 58.1 \times 10^{-46} \text{ cm}^2 \left(1_{-0.028}^{+0.036} \right)_{1\sigma}$$

► Haxton:

[Hata, Haxton, PLB 353 (1995) 422, nucl-th/9503017; Haxton, PLB 431 (1998) 110, nucl-th/9804011]

“a sophisticated shell model calculation is performed ... for the transition to the first excited state in ${}^{71}\text{Ge}$. The calculation predicts destructive interference between the (p, n) spin and spin-tensor matrix elements.”

$$\sigma({}^{51}\text{Cr}) = 63.9 \times 10^{-46} \text{ cm}^2 (1 \pm 0.106)_{1\sigma}$$

	GALLEX		SAGE	
	Cr1	Cr2	Cr	Ar
R	0.953 ± 0.11	$0.812^{+0.10}_{-0.11}$	0.95 ± 0.12	$0.79 \pm^{+0.09}_{-0.10}$
$\langle L \rangle$	1.9 m		0.6 m	

$$R_{\text{Ga}} = 0.87 \pm 0.05$$

$$P_{\nu_e \rightarrow \nu_e}(L, E) = 1 - \sin^2 2\vartheta \sin^2 \left(\frac{\Delta m^2 L}{4E} \right)$$

$$L_{\text{osc}} \lesssim 0.5 \text{ m} \implies \Delta m_{\text{SBL}}^2 \gtrsim 1 \text{ eV}^2 \implies \nu_e \rightarrow \nu_s$$

$$R = \frac{\int dV L^{-2} \sum_i (\text{B.R.})_i \sigma_i P_{\nu_e \rightarrow \nu_e}(L, E_i)}{\sum_i (\text{B.R.})_i \sigma_i \int dV L^{-2}}$$

[Acero, Giunti, Laveder, PRD 78 (2008) 073009, arXiv:0711.4222]

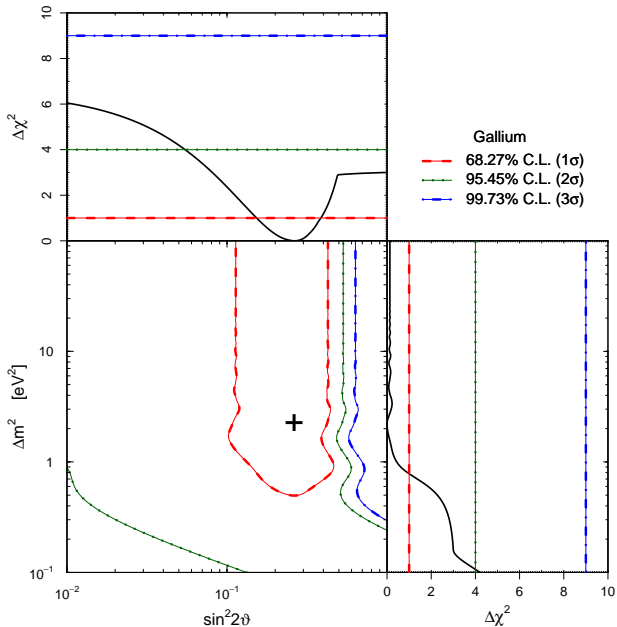

No Osc.

$$\chi^2_{\min} = 8.3$$

$$\text{NdF} = 2$$

$$\text{GoF} = 8.1\%$$

Osc.

$$\chi^2_{\min} = 1.8$$

$$\text{NdF} = 2$$

$$\text{GoF} = 40\%$$

$$\sin^2 2\vartheta = 0.26$$

$$\Delta m^2 = 2.20 \text{ eV}^2$$

[Acero, Giunti, Laveder, PRD 78 (2008) 073009, arXiv:0711.4222]

3+1 Four-Neutrino Mixing

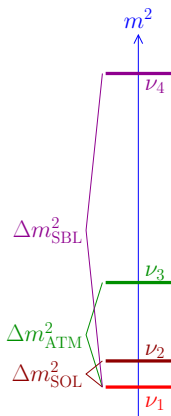

"normal"

$$|U_{e4}|^2 \ll 1$$

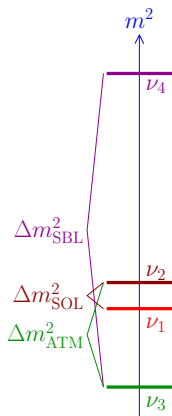

"3ν-inverted"

$$|U_{\mu 4}|^2 \ll 1$$

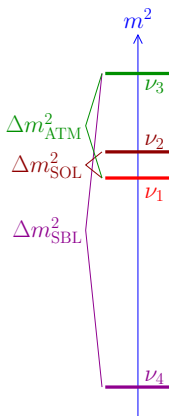

"4ν-inverted"

$$|U_{\tau 4}|^2 \ll 1$$

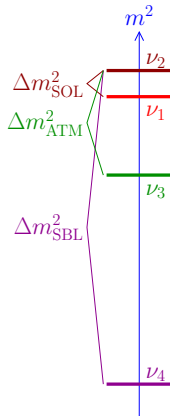

"fully-inverted"

$$|U_{s4}|^2 \simeq 1$$

$$P_{\nu_\alpha \rightarrow \nu_\beta}^{\text{SBL}} = \sin^2 2\vartheta_{\alpha\beta}^{\text{SBL}} \sin^2 \left(\frac{\Delta m_{\text{SBL}}^2 L}{4E} \right) \quad (\alpha \neq \beta)$$

$$\sin^2 2\vartheta_{\alpha\beta}^{\text{SBL}} = 4|U_{\alpha 4}|^2|U_{\beta 4}|^2$$

$$P_{\nu_\alpha \rightarrow \nu_\alpha}^{\text{SBL}} = 1 - \sin^2 2\vartheta_{\alpha\alpha}^{\text{SBL}} \sin^2 \left(\frac{\Delta m_{\text{SBL}}^2 L}{4E} \right)$$

$$\sin^2 2\vartheta_{\alpha\alpha}^{\text{SBL}} = 4|U_{\alpha 4}|^2 (1 - |U_{\alpha 4}|^2)$$

$$U = \begin{pmatrix} U_{e1} & U_{e2} & U_{e3} & U_{e4} \\ U_{\mu 1} & U_{\mu 2} & U_{\mu 3} & U_{\mu 4} \\ U_{\tau 1} & U_{\tau 2} & U_{\tau 3} & U_{\tau 4} \\ U_{s1} & U_{s2} & U_{s3} & U_{s4} \end{pmatrix}$$

$$\sin^2 2\vartheta_{\alpha\alpha}^{\text{SBL}} \ll 1$$



$$|U_{e4}|^2 \simeq \frac{\sin^2 2\vartheta_{\alpha\alpha}^{\text{SBL}}}{4}$$

↑
SBL

LSND

[PRL 75 (1995) 2650; PRC 54 (1996) 2685; PRL 77 (1996) 3082; PRD 64 (2001) 112007]

$$\bar{\nu}_\mu \rightarrow \bar{\nu}_e$$

$$L \simeq 30 \text{ m}$$

$$20 \text{ MeV} \leq E \leq 200 \text{ MeV}$$

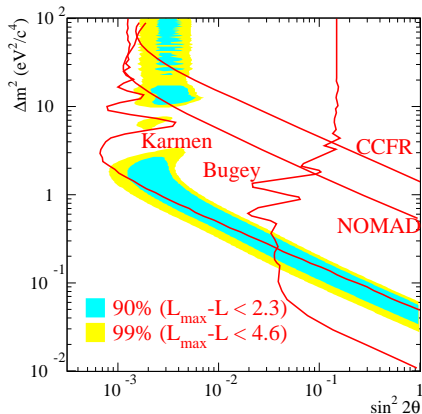
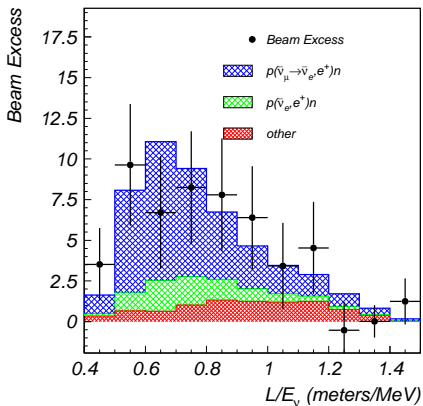

$$\Delta m_{\text{LSND}}^2 \gtrsim 0.2 \text{ eV}^2 \quad (\gg \Delta m_{\text{ATM}}^2 \gg \Delta m_{\text{SOL}}^2)$$

MiniBooNE

[PRL 98 (2007) 231801]

$$\nu_{\mu} \rightarrow \nu_e$$

$$L \simeq 541 \text{ m}$$

$$475 \text{ MeV} \leq E \lesssim 3 \text{ GeV}$$

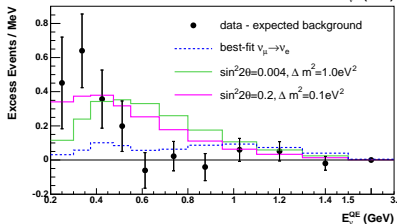
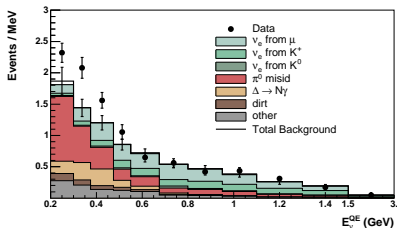

[PRL 102 (2009) 101802, arXiv:0812.2243]

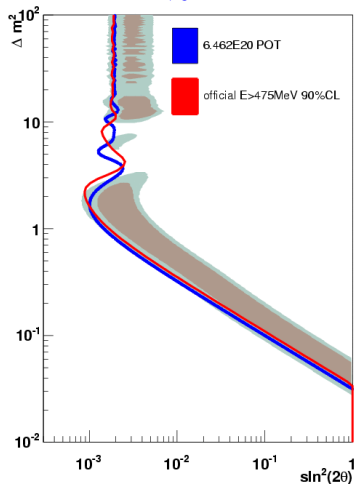

[arXiv:0901.1648]

Low-Energy Anomaly!

MiniBooNE Low-Energy Anomaly

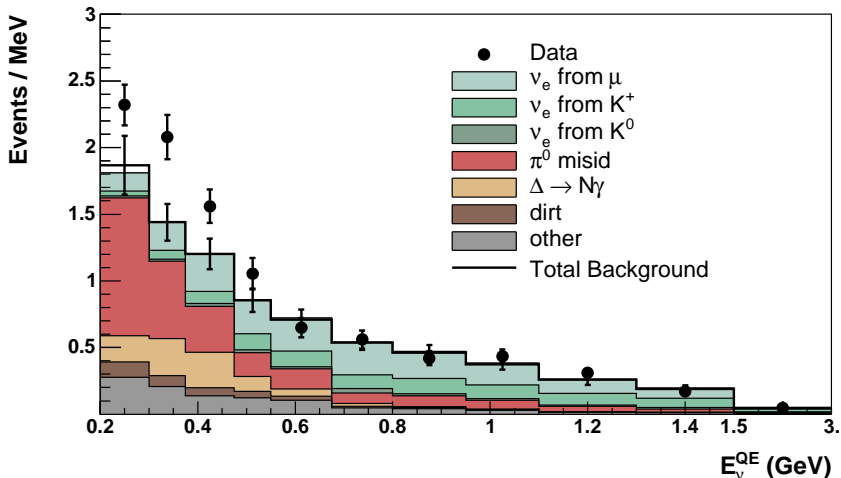

[PRL 102 (2009) 101802, arXiv:0812.2243]

Our Hypothesis: $N_{\nu_j}^{\text{the}} = f_\nu \left(P_{\nu_e \rightarrow \nu_e} N_{\nu_{e,j}}^{\text{cal}} + N_{\nu_{\mu,j}}^{\text{cal}} \right)$

[Giunti, Laveder, PRD 77 (2008) 093002, arXiv:0707.4593; PRD 80 (2009) 013005, arXiv:0902.1992]

$$N_{\nu,j}^{\text{the}} = f_{\nu} \left(P_{\nu_e \rightarrow \nu_e} N_{\nu_e,j}^{\text{cal}} + N_{\nu_{\mu},j}^{\text{cal}} \right)$$

- ▶ Estimated 15% uncertainty of the calculated neutrino flux [MiniBooNE, PRD 79 (2009) 072002, arXiv:0806.1449] is consistent with measured ratio 1.21 ± 0.24 of detected and predicted charged-current quasi-elastic ν_{μ} events [MiniBooNE, PRL 100 (2008) 032301, arXiv:0706.0926]
- ▶ We fit MiniBooNE ν_e and ν_{μ} data using the info at http://www-boone.fnal.gov/for_physicists/data_release/lowe/

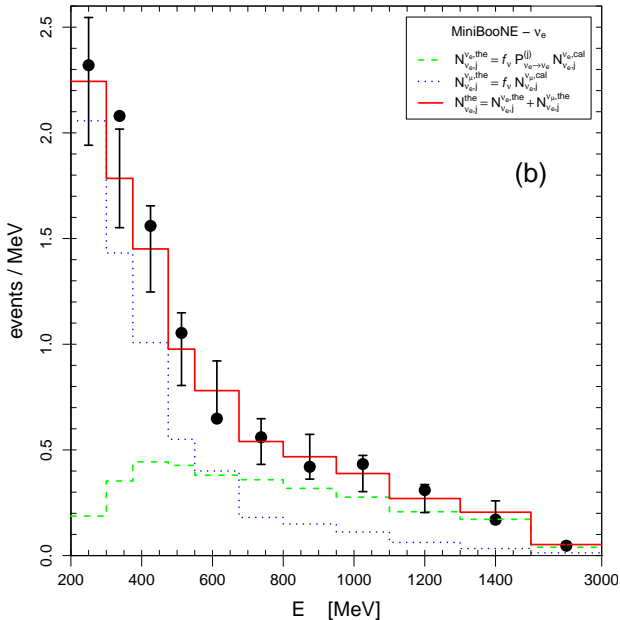

[Giunti, Laveder, 2010, in preparation]

No Osc. & $f_\nu = 1$

$\chi_{\min}^2 = 14.3 + 5.4$

NdF = 3 + 16

GoF = 41%

Our Hypothesis

$\chi_{\min}^2 = 2.0 + 7.6$

NdF = 16

GoF = 89%

$f_\nu = 1.26$

$\sin^2 2\vartheta = 0.32$

$\Delta m^2 = 1.84 \text{ eV}^2$

- ▶ Note similar best-fit values of $\sin^2 2\vartheta$ and Δm^2
- ▶ Gallium best fit: $\sin^2 2\vartheta = 0.26$ and $\Delta m^2 = 2.20 \text{ eV}^2$
- ▶ MiniBooNE best fit: $\sin^2 2\vartheta = 0.32$ and $\Delta m^2 = 1.84 \text{ eV}^2$
- ▶ Parameter Goodness of Fit of combined analysis:
 $\Delta\chi_{\min}^2 = 0.14$ NDF = 2 GoF = 93%

MiniBooNE + Gallium

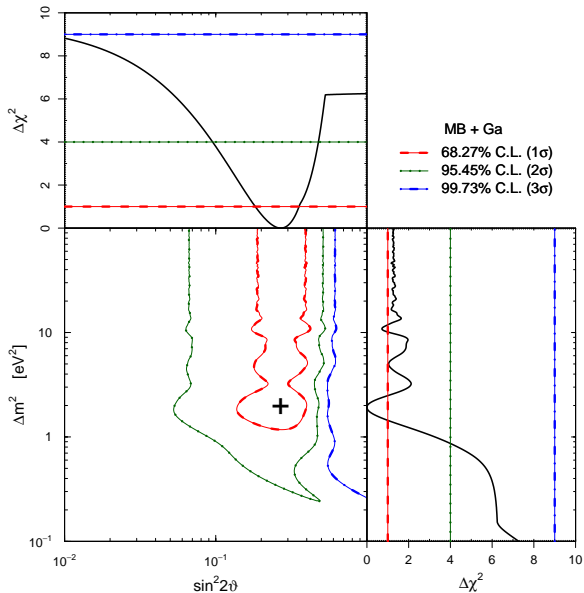

$$\chi^2_{\min} = 2.3 + 9.2$$

$$\text{NdF} = 20$$

$$\text{GoF} = 93\%$$

$$\sin^2 2\vartheta = 0.27$$

$$\Delta m^2 = 1.92 \text{ eV}^2$$

[Giunti, Laveder, 2010, in preparation]

Bugey

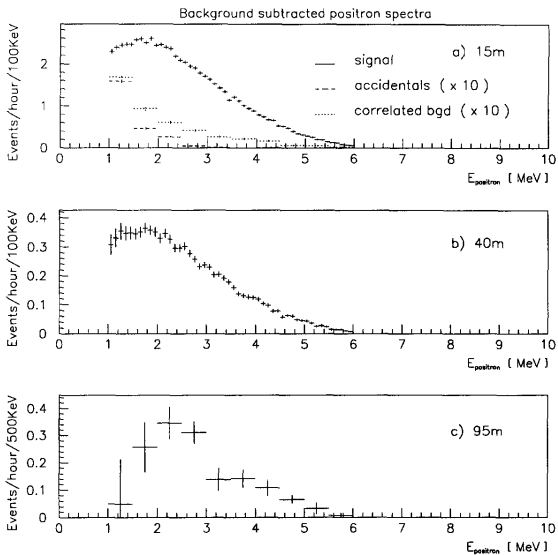

[Bugey, NPB 434 (1995) 503]

Bugey + Chooz

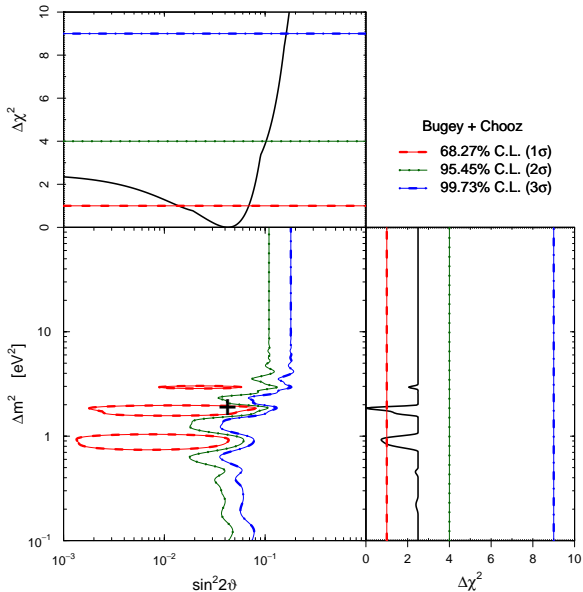

$$\chi^2_{\min} = 48.5$$

$$\text{NdF} = 54$$

$$\text{GoF} = 69\%$$

$$\sin^2 2\vartheta = 0.042$$

$$\Delta m^2 = 1.85 \text{ eV}^2$$

[Acero, Giunti, Laveder, PRD 78 (2008) 073009, arXiv:0711.4222]

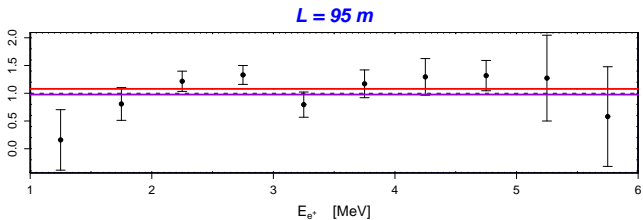
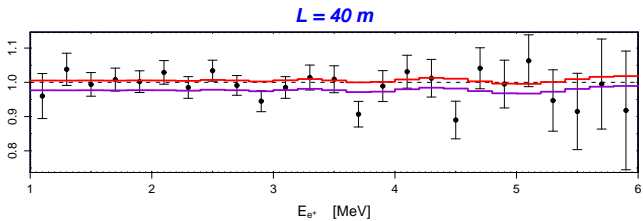
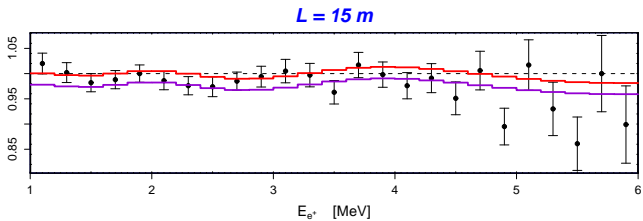

Note similar best-fit values of Δm^2 but different $\sin^2 2\vartheta$:

- ▶ Gallium+MiniBooNE best fit: $\Delta m^2 = 1.92 \text{ eV}^2$ and $\sin^2 2\vartheta = 0.27$
- ▶ Reactors best fit: $\Delta m^2 = 1.85 \text{ eV}^2$ and $\sin^2 2\vartheta = 0.042$

Tritium Beta-Decay

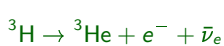

$$\frac{d\Gamma}{dT} = \frac{(\cos\vartheta_C G_F)^2}{2\pi^3} |\mathcal{M}|^2 F(E) p E (Q - T) \sqrt{(Q - T)^2 - m_{\nu_e}^2}$$

$$Q = M_{{}^3\text{H}} - M_{{}^3\text{He}} - m_e = 18.58 \text{ keV}$$

Kurie plot

$$K(T) = \sqrt{\frac{d\Gamma/dT}{\frac{(\cos\vartheta_C G_F)^2}{2\pi^3} |\mathcal{M}|^2 F(E) p E}} = \left[(Q - T) \sqrt{(Q - T)^2 - m_{\nu_e}^2} \right]^{1/2}$$

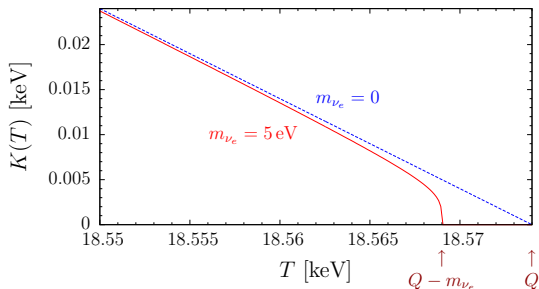

$$m_{\nu_e} \lesssim 2.2 \text{ eV} \quad (95\% \text{ C.L.})$$

Mainz & Troitsk

[Weinheimer, hep-ex/0210050]

future: KATRIN

[hep-ex/0109033] [hep-ex/0309007]

sensitivity: $m_{\nu_e} \simeq 0.2 \text{ eV}$

Neutrino Mixing: $m_{\nu_e} \Rightarrow m_\beta = \sqrt{\sum_k |U_{ek}|^2 m_k^2}$

Mainz: $m_\beta^2 = -0.6 \pm 2.2 \pm 2.1 \text{ eV}^2$

Troitsk: $m_\beta^2 = -2.3 \pm 2.5 \pm 2.0 \text{ eV}^2$

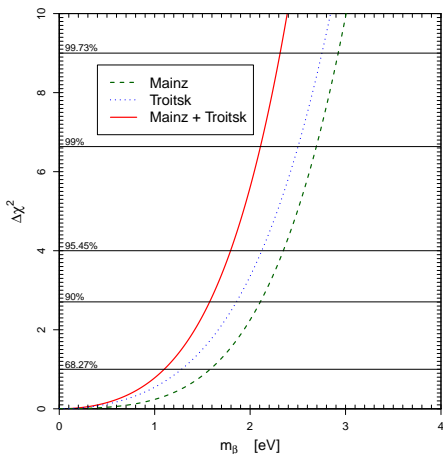

95% C.L. Upper Limits

Mainz: 2.3 eV

Troitsk: 2.0 eV

Mainz+Troitsk: 1.8 eV

Normal and 3ν -inverted schemes

$$m_\beta \lesssim \tilde{m}_\beta \text{ eV} \implies |U_{e4}|^2 m_4^2 \lesssim \tilde{m}_\beta^2$$

$$m_4 \gg m_1, m_2, m_3 \implies m_4^2 \simeq \Delta m_{\text{SBL}}^2$$

$$\Delta m_{\text{SBL}}^2 \lesssim |U_{e4}|^{-2} \tilde{m}_\beta^2$$

$$\sin^2 2\vartheta_{ee}^{\text{SBL}} = 4|U_{e4}|^2 (1 - |U_{e4}|^2) \implies |U_{e4}|^2 = \frac{1}{2} \left(1 \pm \sqrt{1 - \sin^2 2\vartheta_{ee}^{\text{SBL}}} \right)$$

$$|U_{e4}|^2 < \frac{1}{2} \implies |U_{e4}|^2 = \frac{1}{2} \left(1 - \sqrt{1 - \sin^2 2\vartheta_{ee}^{\text{SBL}}} \right)$$

$$\Delta m_{\text{SBL}}^2 \lesssim \frac{2\tilde{m}_\beta^2}{1 - \sqrt{1 - \sin^2 2\vartheta_{ee}^{\text{SBL}}}}$$

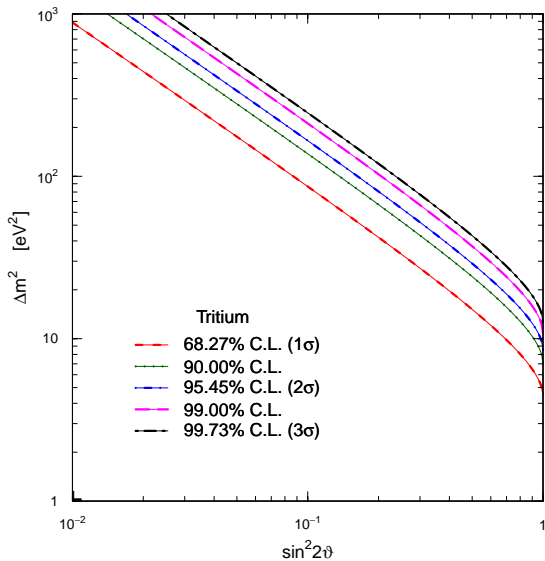

[Giunti, Laveder, 2010, in preparation]

MiniBooNE + Gallium + Reactors + Tritium

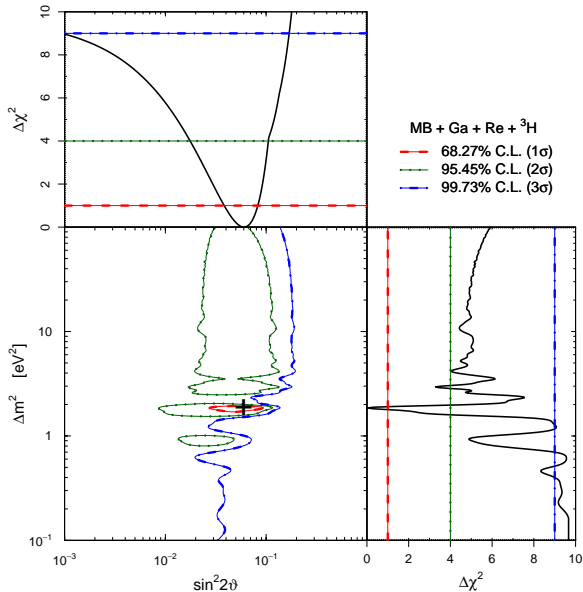

$$\chi^2_{\min} = 4.1 + 58.6$$

$$\text{NdF} = 78$$

$$\text{GoF} = 90\%$$

$$\sin^2 2\theta = 0.06$$

$$\Delta m^2 = 1.85 \text{ eV}^2$$

[Giunti, Laveder, 2010, in preparation]

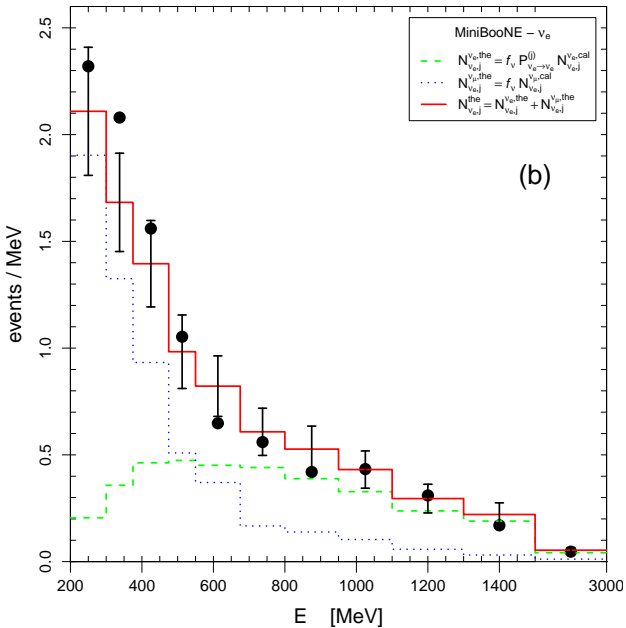

Prediction for Beta-Decay Experiments

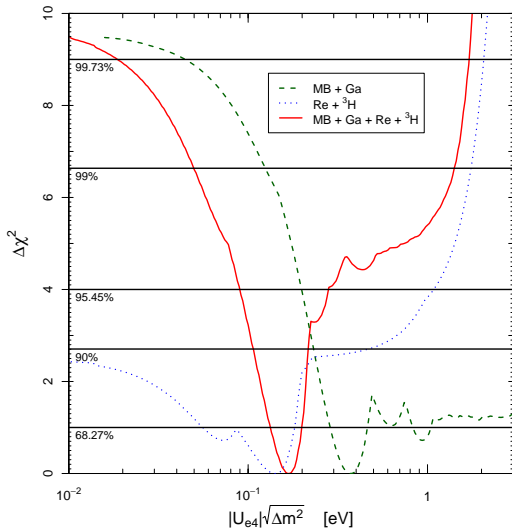

[Giunti, Laveder, 2010, in preparation]

$$m_\beta = \sqrt{\sum_{k=1}^4 |U_{ek}|^2 m_k^2}$$

$$m_\beta \geq |U_{e4}| m_4$$

$$m_\beta \geq |U_{e4}| \sqrt{\Delta m^2}$$

$$\left(|U_{e4}| \sqrt{\Delta m^2} \right)_{\text{bf}} = 0.17 \text{ eV}$$

At 95% C.L.

$$|U_{e4}| \sqrt{\Delta m^2} \in [0.093, 0.28] \text{ eV}$$

Prediction for Neutrinoless Double-Beta Decay

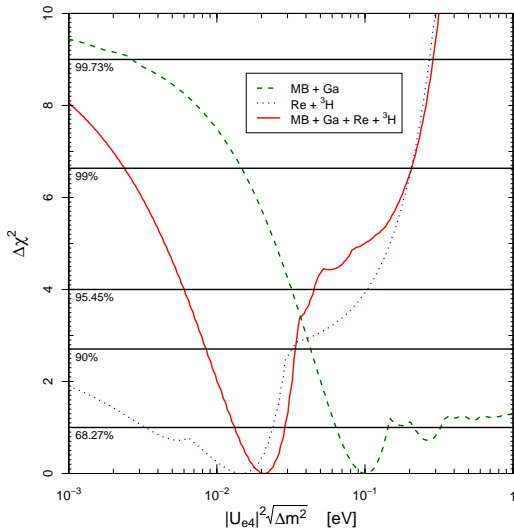

[Giunti, Laveder, 2010, in preparation]

$$m_{2\beta} = \sum_{k=1}^4 U_{ek}^2 m_k$$

$$\left(|U_{e4}|^2 \sqrt{\Delta m^2} \right)_{\text{bf}} = 0.021 \text{ eV}$$

95% C.L. Interval

[0.006, 0.044] eV

Future Tests of (V)SBL ν_e and $\bar{\nu}_e$ Disappearance

The hypothesis of VSBL ν_e disappearance can be tested with high accuracy by future experiments with pure well-known electron neutrino beams:

- ▶ SAGE collaboration is planning a new source experiment (ν_e)
- ▶ Beta-Beam experiments:

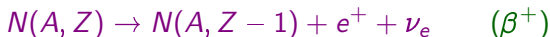
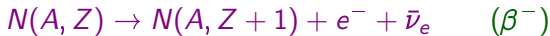

- ▶ Neutrino Factory experiments:



Neutrino Factory

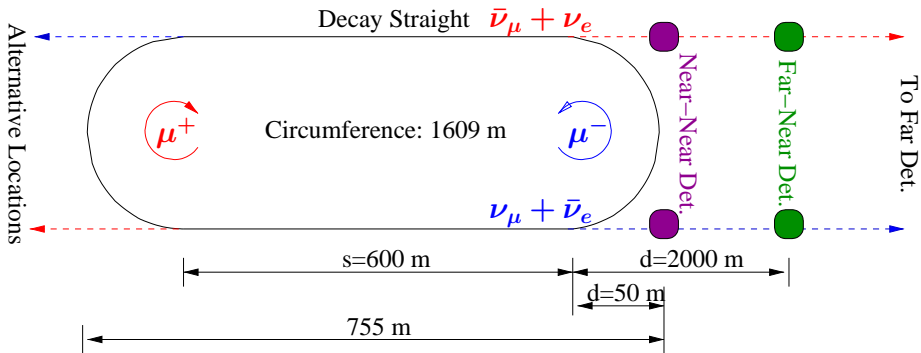

[Giunti, Laveder, Winter, PRD 80 (2009) 073005, arXiv:0907.5487]

Near Detectors: Scintillator or Iron Calorimeter
with perfect flavor identification

Systematic Uncertainties: Cross Section, Detector Normalization,
Energy Resolution and Calibration,
Backgrounds

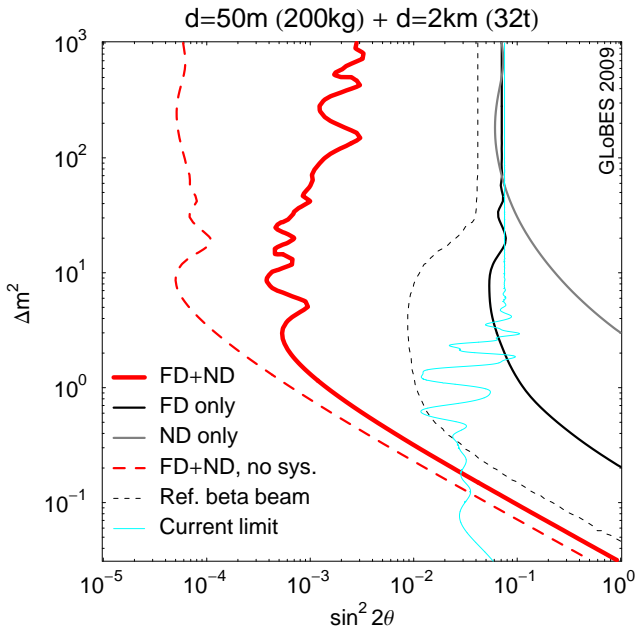

[Giunti, Laveder, Winter, PRD 80 (2009) 073005, arXiv:0907.5487]

Conclusions

- ▶ The Gallium anomaly may be due to $\nu_e \rightarrow \nu_s$ oscillations with $\sin^2 2\vartheta \gtrsim 0.1$ and $\Delta m^2 \gtrsim 1 \text{ eV}^2$
- ▶ These transitions may explain the MiniBooNE Low-Energy-Anomaly and fit the Bugey reactor data
- ▶ Interesting coincidence of best-fit values of Δm^2 at about 2 eV^2 from Gallium, MiniBooNE and Reactor data
- ▶ Combined fit indicates $\sin^2 2\vartheta \approx 0.06$ and $\Delta m^2 \approx 1.85 \text{ eV}^2$
- ▶ Interesting predictions: $m_\beta \approx 0.1 - 0.2 \text{ eV}$ and $m_{2\beta}$ could be as large as about 0.04 eV
- ▶ (V)SBL ν_e and $\bar{\nu}_e$ disappearance can be checked in future
 - ▶ Beta-Beam experiments (pure ν_e or $\bar{\nu}_e$ beam from nuclear decay)
 - ▶ Neutrino Factory experiments (ν_e and $\bar{\nu}_\mu$ from μ^+ decay, or $\bar{\nu}_e$ and ν_μ from μ^- decay)