

# Participation of IN2P3 physicists in the Hyper-Kamiokande experiment

ILance, LLR, LPNHE, OMEGA

October 12, 2021

## Contents

<b>Executive summary</b>	<b>2</b>
<b>1 Scientific context and positioning</b>	<b>3</b>
1.1 Hyper-Kamiokande experiment	3
1.2 Physics program of Hyper-Kamiokande project	4
<b>2 Project schedule</b>	<b>6</b>
2.1 Far detector	6
2.2 Near site	7
<b>3 State of the art</b>	<b>8</b>
3.1 Proton decay with Hyper-Kamiokande	8
3.2 Hyper-Kamiokande as an astrophysical neutrino observatory	9
3.2.1 Neutrinos from Supernovae	9
3.2.2 Atmospheric Neutrinos	10
3.2.3 Solar Neutrinos	11
3.3 Long-baseline neutrino oscillation physics	11
<b>4 Technical contributions to Hyper-Kamiokande</b>	<b>12</b>
4.1 Far detector	12
4.1.1 Overview of the French electronics contribution	12
4.1.2 Digitization	14
4.1.3 Synchronization of the PMTs signals with UTC	17
4.2 Computing	20
<b>5 Experiment resources</b>	<b>22</b>
5.1 Human resources	22
5.2 Financial resources	23
5.3 Organizational supports	23
<b>6 Strength, weaknesses, and risks managements</b>	<b>24</b>
<b>7 Conclusions and requests to IN2P3</b>	<b>25</b>

## Executive summary

The presence of more matter than antimatter in the visible Universe is one of the most puzzling problems in our current understanding of the Universe. Indeed, there is no reason that in an a priori symmetric Universe just after the Big Bang, there should be large structures like galaxy and stars made only of matter without being able to observe similar objects made entirely of antimatter.

In order to explain this mystery, one of the most appealing possibilities is the so-called *leptogenesis* in which the asymmetry between matter and antimatter is originally produced in the leptonic sector via CP violating processes and is later transferred to the baryons.

Among the experimentally accessible sources of CP violation in the leptonic sectors, the most accessible probe is through the phenomenon of neutrino and antineutrino oscillations described by the PMNS mixing matrix [1, 2]. This matrix is a  $3 \times 3$  unitary matrix that, analogously to the CKM matrix in the quark sector, connects three neutrino mass states to the three neutrino flavor states and can be parametrized by three mixing angles ( $\theta_{12}$ ,  $\theta_{23}$ , and  $\theta_{13}$ ) and at least 1 phase ( $\delta_{\text{CP}}$ ). If neutrinos are Majorana particles, there can be two additional phases, but without impact on the oscillation phenomenon.

If  $\sin \delta_{\text{CP}} \neq 0$ , differences in the oscillation probabilities of neutrino and antineutrino correspond to a CP-violation phenomenon. Long baseline neutrino (LBL- $\nu$ ) experiments searching for the differences in the  $\nu_{\mu} \rightarrow \nu_e$  and  $\bar{\nu}_{\mu} \rightarrow \bar{\nu}_e$  appearance probabilities are the most reliable option to search for CP violation in the leptonic sector.

In such experiments, intense beams of  $\nu_{\mu}$  or  $\bar{\nu}_{\mu}$  are created from the decays of hadrons (pions and kaons) produced in the collisions of protons in a long target. The beam composition is measured close to the target by the so-called near detectors, then again, after oscillation, a few hundreds km away, using a far detector which identifies the flavors of the detected neutrinos and antineutrinos via their charged-current (CC) interactions. One of the main challenges of future LBL- $\nu$  experiment is that, in order to measure CP, an increase of statistics by a factor of  $\sim 100$  is needed with respect to the currently running experiments. This increase can be obtained by a combination of higher intensity conventional neutrino beam and larger far detectors.

In this document we present the strategy proposed by the Hyper-Kamiokande (HK) experiment that is the next-generation LBL- $\nu$  experiment in Japan. HK builds on a more than 40 years successful experience of constructing and using large Water Cherenkov detectors in Kamioka (Kamiokande and Super-Kamiokande) and intense neutrino beams from KEK and J-PARC (K2K and T2K experiments).

The HK project has been approved by the Japanese government in 2019 and it is planning to take its first data in 2027. It consists of a Water Cherenkov detector with a fiducial volume eight times larger than Super-Kamiokande and will use the J-PARC neutrino beam. J-PARC is currently able to provide 500 kW neutrino beam and will be upgraded during the T2K-II phase to 1.3 MW. Hence one nominal year of operation of HK will allow to collect a statistics corresponding to more than 20 years of T2K, to provide a quick and powerful confirmation (or rejection) of the current hints for CP violation observed by T2K. For the CP asymmetry values of  $\delta_{\text{CP}} \sim -\pi/2$ , which are currently favored by T2K, HK will measure CP violation with more than  $5\sigma$  significance by 2029 (two years after the first lights).

Moreover, the HK experiment will be a multi-purpose neutrino observatory that is not limited to the measurements of the PMNS matrix parameters with both accelerator and atmospheric neutrinos. It has a very rich program from few MeV to TeV scale, covering solar physics, cosmology through the detection of Diffuse Supernova Neutrino Background (DSNB), search for proton decay, sterile neutrinos and *multi-messenger astrophysics* with the detection of galactic or extra-galactic core-collapse supernovae.

In this document, we present the strategy of the IN2P3 groups to contribute to the HK experiment. This strategy stands on two legs: first, use our long-standing contribution and expertise to the T2K Near Detector complex which is vital to reduce the HK systematic uncertainty and, second, directly contribute to the HK far detector to exploit its extremely rich physics. For the HK far detector, we plan to provide a large part of the photo-detectors electronics chain, including the digitizer, based on a chip developed by the OMEGA lab, and the time generation and distribution system.

# 1 Scientific context and positioning

Neutrino flavor oscillations were first discovered by the Super-Kamiokande (SK) experiment in Japan [3] by observing the atmospheric neutrino flux, and then in the SNO experiment in Canada [4] using the electron neutrino flux coming from the Sun. For these discoveries, the 2015 Nobel Prize in Physics was awarded to T. Kajita and A. B. McDonald. The neutrino oscillation phenomenon can be explained by assuming that the neutrinos have small but non-zero masses, leading to non-degenerate neutrino mass states and the possible presence of mass and flavor eigenstates mixing.

From these breakthroughs, a broad international program has been initiated to measure the parameters needed to describe the oscillation patterns within the PMNS (for Pontecorvo-Masaka-Nakagawa-Sakata) framework, i.e. three mixing angles  $\theta_{12}$ ,  $\theta_{23}$  and  $\theta_{13}$  and two mass-squared differences  $\Delta m_{21}^2$  and  $\Delta m_{31}^2$  along with a CP violation phase  $\delta_{\text{CP}}$ .

As of today the mixing angles and the mass differences have been measured by experiments using different neutrino sources, including neutrinos from the Sun, from the Earth atmosphere, from reactors and from accelerators. The two parameters that are still unknown are  $\delta_{\text{CP}}$ , and the sign of  $\Delta m_{31}^2$  (called “mass ordering”). Both these parameters are accessible with long-baseline experiments, by producing intense  $\nu_\mu$  and  $\bar{\nu}_\mu$  beams and looking at differences in the appearance probability of  $\nu_e$  and  $\bar{\nu}_e$ .

**Long baseline neutrino oscillations (LBL- $\nu$ ) experiments are therefore unique experimental techniques because of their capabilities to precisely determine various oscillations parameters such as  $\theta_{23}$ ,  $\Delta m_{32}^2$ ,  $\theta_{13}$ , the CP violation phase,  $\delta_{\text{CP}}$ , and the mass ordering.**

Currently, two LBL- $\nu$  experiments are taking data: NO $\nu$ A (for NuMI Off-axis  $\nu_e$  Appearance) in the United States and T2K (Tokai To Kamioka) in Japan. These two experiments have taken data for about a decade and will continue providing the most precise measurements of the neutrino mixing parameters for the next few years, until the next generation experiments (DUNE and Hyper-Kamiokande) will start running.

The T2K experiment is a LBL- $\nu$  experiment running across Japan. A description of this experiment and, in particular, of the T2K-II phase has been provided in a dedicated document prepared for this Scientific Council.

Recent results from T2K show hints, at the level of  $\sim 3\sigma$ , of large CP violation in the leptonic sector. This hints will be scrutinized in the next years by T2K-II that, in the most favorable case, could observe CP violation at  $3\sigma$  by 2027.

## 1.1 Hyper-Kamiokande experiment

**In order to reach a  $5\sigma$  discovery of CP violation in the leptonic sector, a new generation of LBL- $\nu$  experiments is needed, namely the DUNE and Hyper-Kamiokande experiments.** The DUNE experiment will use an on-axis beam with a 1300 km long baseline and plans to deploy, using a staged approach, four liquid argon Time Projection Chambers (TPCs) of 40 kt in total as far detectors.

Hyper-Kamiokande, the next generation Water Cherenkov detector that has been approved by Japanese government in 2019, will be operational in 2027 and naturally follows the T2K experiment. Hyper-Kamiokande will use the same neutrino beam and the near detectors as T2K. It will naturally benefit from the beam and near-detector upgrades currently being done for the T2K-II phase, as well as all the expertise and methods developed for 15 years within the collaboration. Also the detection and analysis techniques employed for the far detector will be the same as the ones used for Super-Kamiokande (and for Kamiokande before that).

One key element that is being upgraded is the J-PARC proton main ring (MR) of the accelerator used to produce the neutrino beam that, by the beginning of Hyper-Kamiokande is expected to provide a 1.3 MW beam power (to be compared with the 515 kW currently available for T2K).

The T2K Near Detector complex and in particular the on-going upgrades (described in the T2K document we prepared for this Scientific Council) will also be a key part of the Hyper-Kamiokande experiment that will hence profit from an existing, well-known, and extremely powerful magnetized near detector to characterize the neutrino beam and neutrino interactions before the oscillations. Expected performances of the upgraded ND280 for the T2K and Hyper-Kamiokande era can be found in [5].

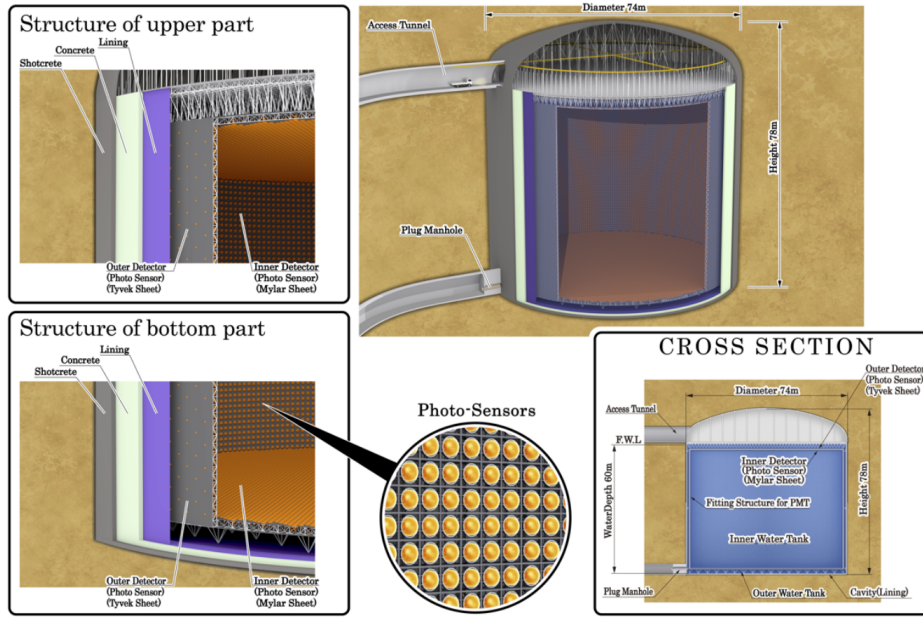

Figure 1: Scheme of the Hyper-Kamiokande far detector.

The main component of this program is the construction of a new large-scale water Cherenkov neutrino detector in the Kamioka mines. The chosen site is 8 km south of the current Super-Kamiokande detector, with the same baseline, energy and off-axis angle for neutrinos from the J-PARC accelerator. The cavern has a rock overburden of 650 m, corresponding to 1,750 meters of water equivalent. As depicted in Fig. 1, this new far detector called Hyper-Kamiokande will be a cylinder with a diameter of 68 m and an height of 71 m and will host 260 kt of pure water. The fiducial volume will be 8 times larger than the existing Super-Kamiokande detector and will be instrumented with up to 40,000 detection units, including at least 20,000 20-inch photomultiplier tubes (PMTs) from Hamamatsu (R12860HQE). Compared to Super-Kamiokande PMTs, these newly-developed PMTs have a detection efficiency two times higher, a reduced dark rate (4.2 kHz) and a timing resolution reduced by a factor of two (2.6 ns full width at half maximum). This setup will be complemented with a few thousands of so-called multi-PMTs based on a concept similar to KM3NET's and currently under development. The detector photo-coverage will depend on the final number of PMTs but will be at least 20%. An outer detector surrounding the inner detector and equipped with 8,000 3-inch PMTs will be used to detect charged particles entering the detector fiducial volume from outside.

Contrary to the Super-Kamiokande design, the frontend electronics collecting the signals from the PMTs will be located under water. This novel design allows to reduce the length of the analog cables between the digitizers and the PMTs, therefore enhancing the physics output from the signal while reducing the weight of the structure. However, it requires the electronics to be installed in some water-tight boxes located under-water, which requires a high reliability of both the boxes and the electronics. In the current design, there will be 24 photosensors connected to a water-tight box. All the systems required to monitor and control the electronics, including digitization, low- and high-voltage, clock and counter, must then be distributed to each box.

**Hyper-Kamiokande will be the most massive and sensitive underground observatory for neutrinos in the Universe in the MeV-multiGeV range.** After 10 years of data taking, this far detector should register about 4,200  $\nu_e$  events and about 23,000  $\nu_\mu$  events from J-PARC, thus increasing statistics by a factor of 40 compared to what has been achieved by T2K so far.

## 1.2 Physics program of Hyper-Kamiokande project

Thanks to this very large statistics and the constraints on the systematic parameters (cross-sections and flux) obtained with the near detectors, a combined analysis using disappearance and appearance

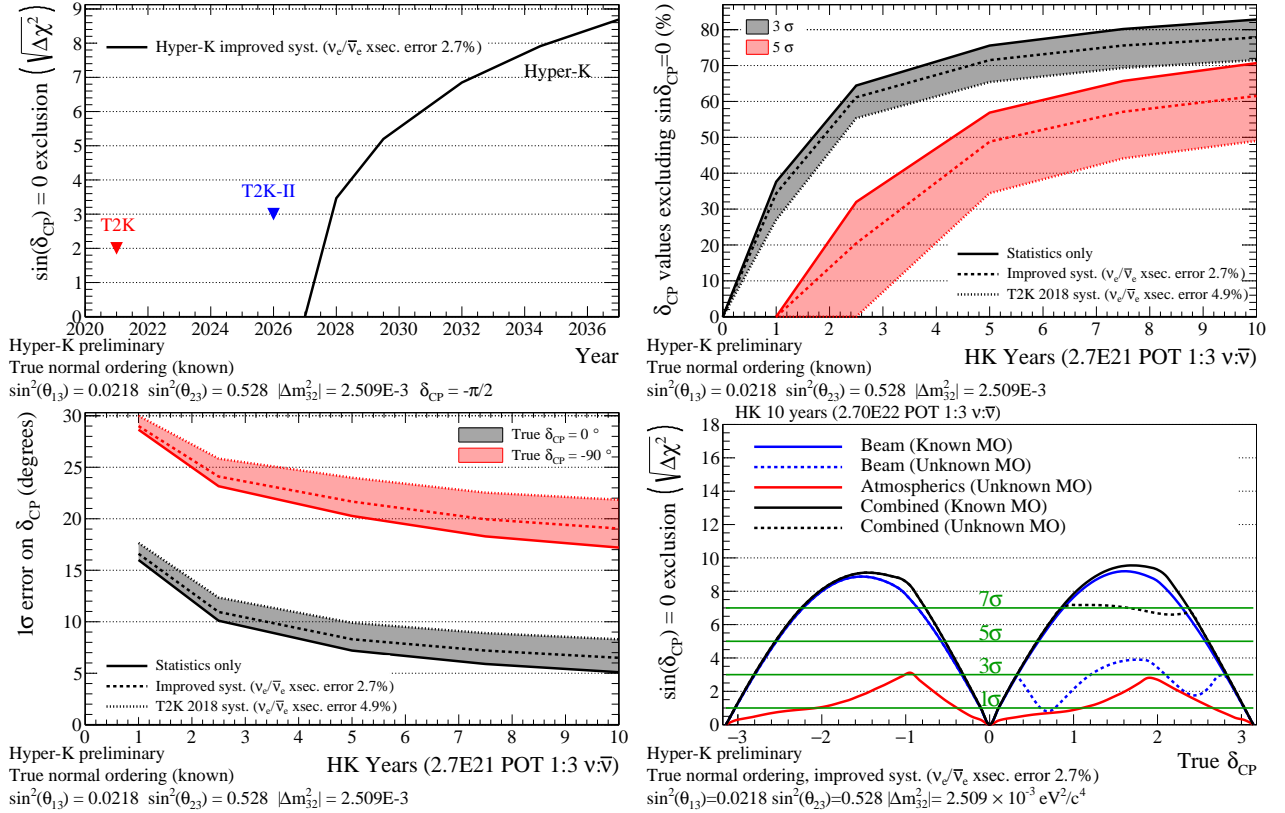

Figure 2: Top Left: T2K, T2K-II and Hyper-Kamiokande sensitivity on the exclusion of CP conservation for  $\delta_{CP} = -\pi/2$ . Top right: Percentage of true  $\delta_{CP}$  values for which  $\sin(\delta_{CP}) = 0$  can be excluded, as a function of HK-years. The shaded areas show the span of possible values, for various systematic errors assumptions. Bottom left:  $1\sigma$  resolution of  $\delta_{CP}$ , as a function of HK-years. Bottom right: Sensitivity to exclude  $\sin(\delta_{CP}) = 0$ , as a function of true  $\delta_{CP}$  value, for 10 HK-years and true normal mass ordering.

samples will provide an exquisite sensitivity to the  $\delta_{CP}$  phase.

In Fig. 2 we report some highlights of the Hyper-Kamiokande sensitivity to CP violation. For the most favorable value of  $\delta_{CP}$ , close to  $-\pi/2$ , Hyper-Kamiokande will reach  $5\sigma$  sensitivity by 2029. For other values of  $\delta_{CP}$ , assuming a mild reduction of systematics with respect to T2K, Hyper-Kamiokande will have more than  $5\sigma$  ( $3\sigma$ ) sensitivity for 50% (70%) of the possible values of  $\delta_{CP}$  after 5 years of operation. After 10 years, Hyper-Kamiokande will measure  $\delta_{CP}$  with a precision ranging between 7 and 20 degrees depending on the value of  $\delta_{CP}$ .

Finally, it should be highlighted that Hyper-Kamiokande will have a relatively short baseline of 295 km making the sensitivity to the mass ordering limited. As shown in Fig. 2 this limitation will be compensated by the large sample of atmospheric neutrinos, which has large sensitivity to mass hierarchy (see Super-Kamiokande document for the Scientific Council). Even in the case in which the mass ordering will not be known by 2027, the combination of beam and atmospheric neutrinos will allow to break the degeneracies between CP and matter effects and measure the two separately with Hyper-Kamiokande alone.

The rich Hyper-Kamiokande physics program goes well beyond the measurements of neutrino oscillation parameters and neutrino cross-sections. For example, thanks to its gigantic mass of purified water, the Hyper-Kamiokande far detector has an excellent sensitivity to test models predicting the proton decay such as  $p \rightarrow \pi^0 + e^+$ . After 20 years of data-taking (similar to Super-Kamiokande's overall period), Hyper-Kamiokande should be able to put a proton lifetime limit on decay into this mode to  $10^{35}$  years, which is 10 times better than the current limit from Super-Kamiokande [6].

In addition, Hyper-Kamiokande will detect thousands of electron antineutrinos (via inverse beta-decay) and electron neutrinos (via elastic scattering) from SN bursts in the galactic center. Using the

elastic scattering events, it will be possible to reconstruct the direction towards a SN at a distance of 10 kpc with an accuracy of about 1 degree. Even for distances of 4 Mpc, we will observe few tenths of neutrinos in Hyper-Kamiokande and, at such distances, one SN is expected every three years. The events observed in Hyper-Kamiokande will allow to provide detailed information about the time profile and the energy spectrum to further inspect SN explosion mechanism.

## 2 Project schedule

The Hyper-Kamiokande experiment has been approved by Japanese government in 2019. The beginning of the operation is expected by 2027.

The total Hyper-Kamiokande budget approved by the Japanese government is of 50.2 B¥ (~ 400 M€) and will allow to build the far detector equipped with 20,000 PMTs and to perform the necessary upgrades of the J-PARC beamline and of the near detector suite, including the construction of a new pit for an Intermediate Water Cherenkov Detector (IWCD) at 1 km distance from the neutrino target.

The Hyper-Kamiokande collaboration is currently composed of 450 researchers from 19 countries and is steadily growing since the approval of Hyper-Kamiokande. International contributions to the project are being currently defined and will be mainly concentrated on the Near Detectors (both ND280 and IWCD), the HK outer detector, the multi-PMTs for the inner detector, the 20 inches PMT electronics, and the computing.

These contributions are expected to add ~ 20% to the total Hyper-Kamiokande budget. Figure 3 shows the overall construction schedule of the Hyper-Kamiokande experiment.

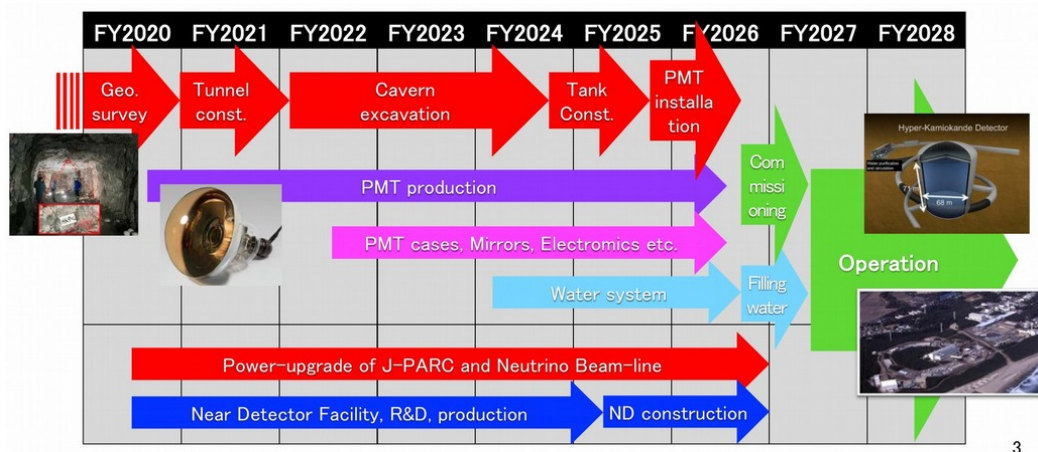

Figure 3: Construction schedule of the Hyper-Kamiokande experiment

### 2.1 Far detector

The construction of the Hyper-Kamiokande far detector has officially started since 2020. After the successful completion of the geographical surveys, the construction of the 2 km long access tunnel has started in 2021 and it is expected to be completed by the end of the JFY 2021. The next steps will then be the excavation of the cavern (~ 2.5 years) and the construction of the water tank (1 year).

Concerning the large PMTs a contract with Hamamatsu has been signed and the production has started with more than 1500 20" Box&Line PMTs that have already been delivered to the collaboration. The production will continue until 2026 in order to deliver the total number of 20" PMTs.

The other photo-detection modules considered by the collaboration are the so-called multi-PMTs (mPMTs). These units, similar to the one being deployed by the KM3NET collaboration, will host 19 3" PMTs. The main advantage of the mPMTs is their higher granularity which improves the vertex resolution and the particle identification in the whole detector, and even more on the edge of the detector, allowing to increase the fiducial volume and reducing background contamination. Several countries (Italy, Canada, Poland) are actively pursuing the developments of this technology. The total

number of mPMTs will depend on the available funds and the mass production capabilities but we expect to add a number of mPMTs comprised between 2k and 5k. The mPMTs are also the baseline option to instrument the IWCD, which will be described in the next section.

The PMTs will be installed in Hyper-Kamiokande in the first half of 2026 prior to the beginning of the water filling. Since the electronics for the Hyper-Kamiokande PMTs will be under water, it has to be ready for the installation in 2026. Currently different R&D are on-going for the digitizer and the clock distribution system. [A review of all the digitizer projects and of the clock distribution system will be held in Summer 2022 and the items will officially be assigned after this review.](#)

Concerning the **digitizer**, three options are being investigated:

- A solution based on the QTC chip developed by Japanese collaborators and currently used in the SK readout electronics;
- A solution based on discrete components proposed by Italian collaborators;
- The solution proposed by the French teams based on a new chip (HKROC) produced by the OMEGA lab.

For the **clock synchronization system**, French groups from IN2P3 and CEA are collaborating with INFN and we propose to provide the full synchronization chain, from the generation of the clock through atomic clocks and Global Navigation Satellite System (GNSS) to the end-point of the clock distribution system on the digitizer board. The goal is to synchronize all the PMTs at the level of 100 ps.

The two R&Ds will be concluded by Summer 2022 and, if these items are assigned to French groups, mass production of the components will start in 2023 in order to be ready for installation in 2026.

## 2.2 Near site

As explained in the previous section, one of the main strengths of Hyper-Kamiokande is the existence of the neutrino beamline and of the near detector complex at J-PARC.

An intense beam is mandatory in order to collect enough statistics at the far detector for the discovery of CP violation while the near detector has the role of reducing the flux and cross-section systematics uncertainties in order to cope with the huge statistics collected at the far detector.

The beamline and the 280-m near-detector complex had been both built for T2K and are being upgraded for T2K-II. The beamline is operated by KEK and will be employed for Hyper-Kamiokande.

ND280 instead, was mostly built by international collaborators of T2K and discussions between the two collaborations are on-going in order to define how the transition from T2K to Hyper-Kamiokande collaboration will occur. This discussion is facilitated by the fact that most of the groups (including French groups) that constructed and operated ND280 for T2K are also part of the Hyper-Kamiokande collaboration.

Currently, the T2K Near Detector complex at 280 m host three detectors: INGRID, WAGASCI/Baby-MIND, and the off-axis ND280 that is being upgraded for T2K-II.

INGRID is an on-axis detector and it is used to monitor the beam profile and direction on a day-by-day basis.

WAGASCI/Baby-MIND is a newly built Near Detector, installed in 2017 at  $\sim 1.5$  degrees. WAGASCI consists of a grid of plastic scintillators filled with water while Baby-MIND is a magnetized calorimeter installed downstream and used to measure the charge of the leptons produced by neutrino and antineutrino interactions in WAGASCI.

The off-axis ND280 consists in a set of detectors installed inside the UA1 magnet. The detectors are located at the same off-axis angle of Super-Kamiokande and Hyper-Kamiokande and it is used to constrain flux and cross-section systematics in the T2K oscillation analysis by using the muon kinematics. With the upgrade currently on-going for T2K we expect to improve the reconstruction of the muons and to reduce the threshold to reconstruct the hadronic part of the neutrino interaction.

The upgraded ND280 and INGRID are expected to be the near detectors configuration of HK at the beginning of Hyper-Kamiokande, possibly accompanied by IWCD which will be discussed below.

INGRID will keep its role of monitoring neutrino beam direction and position. ND280 will keep its role of measuring the neutrino flux before the oscillation and constrain the neutrino-nucleus interaction uncertainties. ND280 will be at the same off-axis angle as Hyper-Kamiokande and will be the only magnetized detector in HK. It will have the crucial role to control the  $\nu/\bar{\nu}$  systematic uncertainties which are fundamental for  $\delta_{\text{CP}}$  measurements.

ND280 will also provide the important advantage of anchoring the understanding of systematic uncertainties in an upgraded beam to a well-known detector, already under operation since years. This role, which highly enhance the credibility of the fast discovery of CP-violation in HK also poses the challenge of keeping in operation the ND280 detector (notably the not-upgraded subsection) in the next  $\sim 5$ -10 years. **The contribution of the IN2P3 group to ND280 upgrade and to its maintenance and operation, is therefore a fundamental contribution to Hyper-Kamiokande.**

For small values of  $\delta_{\text{CP}}$  or to perform a precise measurement of the angle, the level of understanding of systematics attainable with the ND280 Upgrade might not be sufficient. In particular, it is expected that the target mass of ND280 will be large enough to make precise measurements of  $\nu_{\mu}$  but it will be not sufficient to measure  $\nu_e/\nu_{\mu}$  cross-section at the level of 2% needed to reach the ultimate Hyper-Kamiokande sensitivity.

The Hyper-Kamiokande collaboration is considering two options to further boost the potential of the near site: the IWCD and a possible further upgrade of ND280.

IWCD will be located 750 m downstream the neutrino target. In its default configuration, IWCD will move spanning off-axis angles from 1 to 4 degrees and, thanks to its large mass of  $\sim 1$  kt will be able to collect a large sample of  $\nu_e$  interactions. IWCD will be equipped with  $\sim 500$  mPMTs and will measure neutrino cross-section on oxygen using the same detection technique as Hyper-Kamiokande. It will therefore allow to highly reduce systematic uncertainties not only from neutrino cross-section models, but also, from detector model, which will be very similar between Hyper-Kamiokande and IWCD. IWCD is highly complementary with ND280 because its main limitations, i.e. the fact that it will mostly be sensitive to the leptons (hadrons are typically below the Cherenkov threshold at the Hyper-Kamiokande energies) and the fact that it will not be able to measure the lepton charge, are the main strengths of ND280.

Further upgrades of ND280 are also being considered by some groups in Hyper-Kamiokande. For example, if the T2K-II data will prove that the Super Fine Grained Detector (Super-FGD) is capable of distinguishing  $\nu_e$  from  $\nu_{\mu}$  with high efficiency as predicted by our preliminary simulation, replacing part of the existing ND280 tracker system (FGDs and vertical TPCs) with a  $\sim 10$  ton detector with 3D printed cubes will be an attractive option to collect a large number of  $\nu_e$  interactions in ND280 [7].

### 3 State of the art

Hyper-Kamiokande is the third generation Water Cherenkov detector that will be built in Kamioka, after KamiokaNDE and Super-Kamiokande. With respect to its predecessors, Hyper-Kamiokande will have a larger target mass with a fiducial volume 8 times larger than Super-Kamiokande.

In addition to the long-baseline neutrino oscillation physics program Hyper-Kamiokande will naturally follow Super-Kamiokande as the most sensitive observatory for rare events such as proton-decay, neutrinos emitted in SN explosions, and will perform precise measurements of solar and atmospheric neutrinos.

#### 3.1 Proton decay with Hyper-Kamiokande

Grand Unified Theories (GUT) predict proton and bound nucleon decays, both of which are processes that violate baryon number. Such processes have been searched for a long time and Super-Kamiokande has set the strongest limit on proton decay with a half-life larger than  $2.4 \times 10^{34}$  years [6]. The huge size of Hyper-Kamiokande will make it the most sensitive experiment in the search for the proton decay, surpassing the Super-Kamiokande sensitivity after two years of data taking.

The two favorite modes from two dominant classes of GUT models are the  $p \rightarrow e^+\pi^0$  and  $p \rightarrow \bar{\nu}K^+$ , but the experiment will have world-leading sensitivity to several other channels, as shown in Fig. 4.



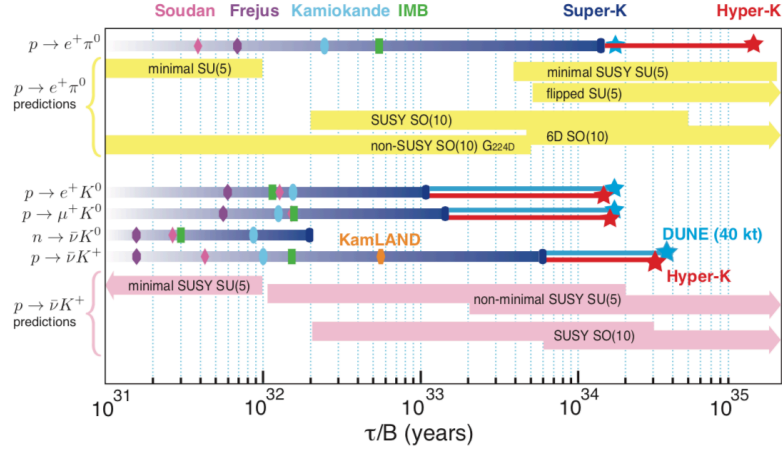

Figure 4: A comparison of historical experimental limits on the rate of nucleon decay for several key modes to indicative ranges of theoretical prediction. Included in the figure are projected limits for Hyper-Kamiokande and DUNE based on 10 years of exposure.

The  $p \rightarrow e^+\pi^0$  decay has a very clean event topology, with no undetected particles in the final state. As a result, it is possible to fully reconstruct the proton's mass from its decay products.

The primary background to this and all nucleon decay searches is atmospheric neutrinos with processes such as  $\nu_e + n \rightarrow e^- + \pi^0 + p$ , where the proton is below the Cherenkov threshold.

Figure 5 shows the  $3\sigma$  discovery potential for observing a  $p \rightarrow e^+\pi^0$  signal based on these estimates. Projections from other experiments, including DUNE and Super-K, as well as the expectation for two Hyper-K tanks, the second one starting six years after the first, are shown for comparison. A proton decay signal can be observed at  $3\sigma$  if the proton lifetime is less than  $10^{35}$  years with a 20 year exposure, surpassing other experiments by nearly an order of magnitude. If the proton lifetime is near the current Super-K limit of  $\sim 7 \times 10^{34}$  years, Hyper-Kamiokande would expect to see a signal at  $3\sigma$  significance in its first three years of running.

The other main decay mode, predicted by supersymmetric GUT models, is the  $p \rightarrow \bar{\nu}K^+$ . Unlike the search for  $e^+\pi^0$  events it is not possible to fully reconstruct the initial proton kinematics since the neutrino is essentially invisible to Hyper-K. Further, the kaon is emitted with momentum of 340 MeV/c, which is well below its Cherenkov threshold in water. Searching for this decay mode in Hyper-K is performed based on identifying a monochromatic kaon with the appropriate momentum by reconstructing its decay particles, that can be either a 236 MeV/c muon from the  $K^+ \rightarrow \nu + \mu^+$  decay mode (64% branching fraction) or the  $\pi^0$  from the  $K^+ \rightarrow \pi^+\pi^0$  decay.

Figure 6 shows the  $3\sigma$  discovery potential as a function of running time for the  $p \rightarrow \bar{\nu}K^+$  search.

### 3.2 Hyper-Kamiokande as an astrophysical neutrino observatory

Right from the start of their history, the gigantic Water Cherenkov detectors have been particularly successful in detecting neutrinos from astrophysical sources. Back in 1987, Kamiokande detected few neutrinos issued by the famous 1987A Supernova, while in 1998 Super-Kamiokande observed for the first time oscillations of neutrinos produced in the atmosphere and in the Sun. Super-Kamiokande is currently being filled with Gadolinium in order to improve its capability of detecting neutrons with the goal of observing neutrinos from the diffuse SN background (DSNB).

#### 3.2.1 Neutrinos from Supernovae

Hyper-Kamiokande, thanks to its large mass, will detect thousands of  $\bar{\nu}_e$  (via inverse  $\beta$ -decay) and  $\nu_e$  (via elastic scattering) from SN bursts in the galactic center (see Fig. 7). Thanks to the elastic scattering events it will be possible to reconstruct the direction towards a Supernova at a distance of 10 kpc with an accuracy of about 1 degree. The events observed in Hyper-Kamiokande will allow to provide detailed information about the time profile and the energy spectrum for inspecting Supernova

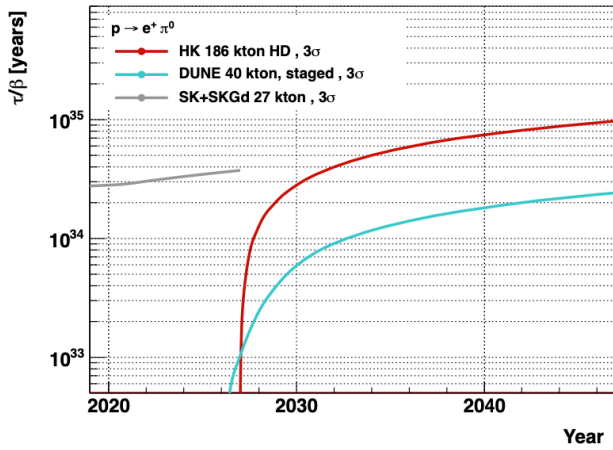

Figure 5: Comparison of the  $3\sigma p \rightarrow e^+\pi^0$  discovery potential as a function of year Hyper-K (red solid) assuming a single tank as well as that of the 40 kt liquid argon detector DUNE (cyan solid) following [8]. In the red line an additional Hyper-K tank is assumed to come online six years after the start of the experiment. Super-K’s discovery potential in 2026 assuming 23 years of data is also shown.

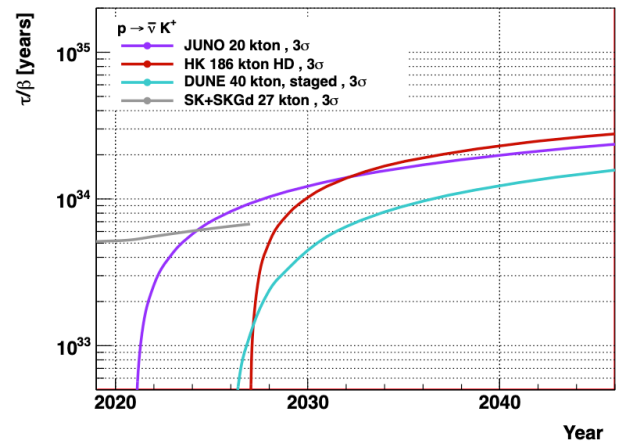

Figure 6: Comparison of the  $3\sigma p \rightarrow \bar{\nu}K^+$  discovery potential as a function of year for the Hyper-K as well as that of the 40 kt DUNE detector (cyan solid) based on [8] and the 20 kt JUNO detector based on [9]. The red line denotes a single Hyper-K tank, while the red line shows the expectation when a second tank comes online after six years. The expected discovery potential for Super-K by 2026 assuming 23 years of data is also shown.

explosion mechanism. Such mechanisms are still largely unknown due to the fact that no neutrinos from Supernova explosions have been observed since the 1987A Supernova explosion.

With Hyper-Kamiokande it will be possible to detect neutrinos also from extra-galactic Supernova explosions. Even for distances of 4 Mpc, we will observe few tenths of neutrinos in Hyper-Kamiokande and, at such distances, one Supernova is expected every three years.

Hyper-Kamiokande will also be able to detect the Supernova relic neutrinos (SRN) that are neutrinos produced by all Supernova explosions since the beginning of the universe. Such neutrinos fill the present universe and have a flux of few tens/cm<sup>2</sup>/sec. The observation of SRN would allow to understand how heavy elements have been synthesized in stellar formation and it is the main goal of the SK-Gd project [10].

Even if the first observation of SRN is performed at Super-Kamiokande, a mega-ton exposure in Hyper-Kamiokande will allow to collect a large statistics of SRN in the energy range between 16 and 30 MeV, the region where both spallation and atmospheric backgrounds are negligible. The number of expected events detected in Super-Kamiokande, JUNO and Hyper-Kamiokande as a function of time is shown in Fig. 8.

### 3.2.2 Atmospheric Neutrinos

Hyper-Kamiokande will also collect a large sample of atmospheric neutrinos. Such measurements will complement the long-baseline program and joint analyses between beam and atmospheric neutrinos are planned in order to improve the sensitivity to the mass ordering. The matter effects are, in fact, rather small for the 295 km baseline of Tokai to Hyper-Kamiokande and the experiment will have limited sensitivity to the mass ordering.

Several experiments, running and planned, are trying to determine the mass ordering so we expect that it will be determined before the beginning of Hyper-Kamiokande operation. In case it will not, the combination of atmospheric and beam neutrinos will allow to determine the ordering with the sensitivity shown in Fig. 9. Such combination will also improve the sensitivity to the octant of  $\sin^2\theta_{23}$ .

The interested reader may have a look at the dedicated document concerning atmospheric neutrinos at Super-Kamiokande provided to the IN2P3 CS.

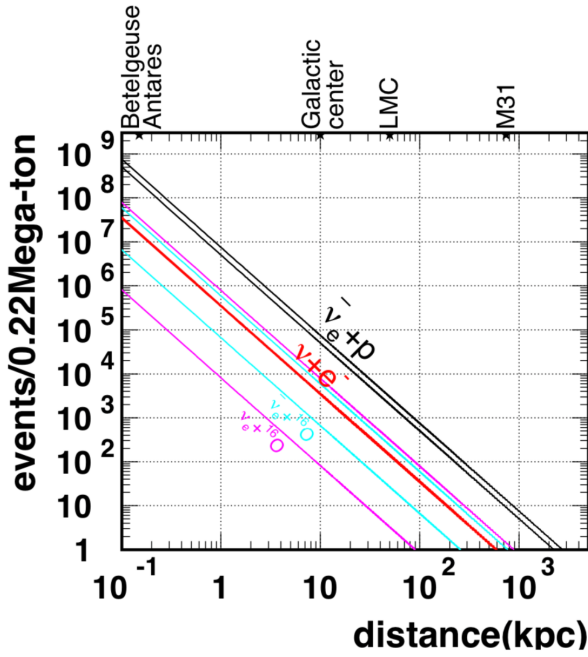

Figure 7: Expected number of supernova burst events for each interaction as a function of the distance to a supernova. Figure taken from [10].

### 3.2.3 Solar Neutrinos

As in the case of Super-Kamiokande, Hyper-Kamiokande will detect solar neutrinos from the  $^8\text{B}$  with an energy threshold of a few MeV. The main output of the Hyper-Kamiokande solar neutrino program will be the observation of the spectrum upturn and of the day night asymmetry.

## 3.3 Long-baseline neutrino oscillation physics

As explained in the previous section, the main goal of Hyper-Kamiokande will be the discovery of CP violation in the leptonic sector. This measurement relies on the high-statistics measurement of  $\nu_e$  and  $\bar{\nu}_e$  oscillation probabilities and on a superb knowledge of neutrino flux and spectra.

In this respect Hyper-Kamiokande will have the advantage of profiting, from day 1, of a well-understood neutrino beam and near detector complex, informed by more than 15 years of running from T2K. This will allow to make fast but precise measurements of CP violation with HK right from the beginning.

The expected sensitivity of Hyper-Kamiokande to  $\delta_{\text{CP}}$  is shown in Fig. 2. Of course, a discovery of CP violation is only possible if CP is violated in the leptonic sector. In case of large CP violation, with  $\delta_{\text{CP}} \sim -\pi/2$ , the state of the art at the beginning of Hyper-Kamiokande could be that early hints of CP violation had been observed by T2K and NO $\nu$ A. In this scenario Hyper-Kamiokande will be able to confirm possible hints at the  $3\sigma$  level in a few months and discover CP violation with  $5\sigma$  significance after two years of run, in  $\sim 2029$ .

In case of smaller values of  $\delta_{\text{CP}}$ , Hyper-Kamiokande will be able to observe CP violation at  $3\sigma$  ( $5\sigma$ ) for 50% (70%) of the values of  $\delta_{\text{CP}}$  after 5 years of running and will be limited by the systematics after  $\sim 10$  years of running.

The other future LBL experiment that will come online in the late 2020s is DUNE. The DUNE collaboration has recently released its low-exposure sensitivity [11].

We believe that Hyper-Kamiokande will have several advantages with respect to DUNE, especially in the short-term:

- according to the current plans Hyper-Kamiokande is expected to start data taking in 2027 while DUNE will start in 2029;

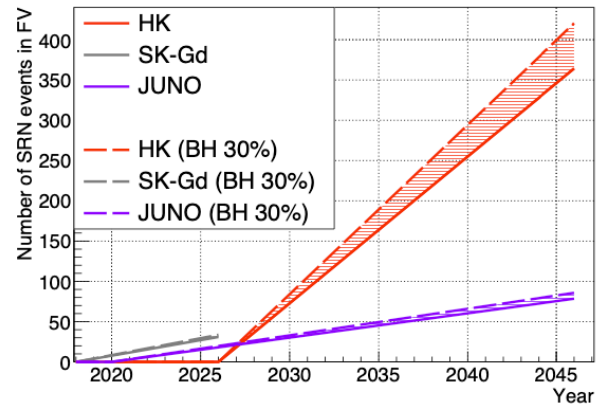

Figure 8: Expected number of inverse beta decay reactions due to supernova relic neutrinos in several experiments as a function of year. The neutrino temperature is assumed to be 6 MeV. Solid line corresponds to the case, in which all the core-collapse supernovae emit neutrinos with the particular energy. Dashed line corresponds to the case, in which 30% of the supernovae form black holes and emit higher energy neutrinos corresponding to the neutrino temperature of 8 MeV.

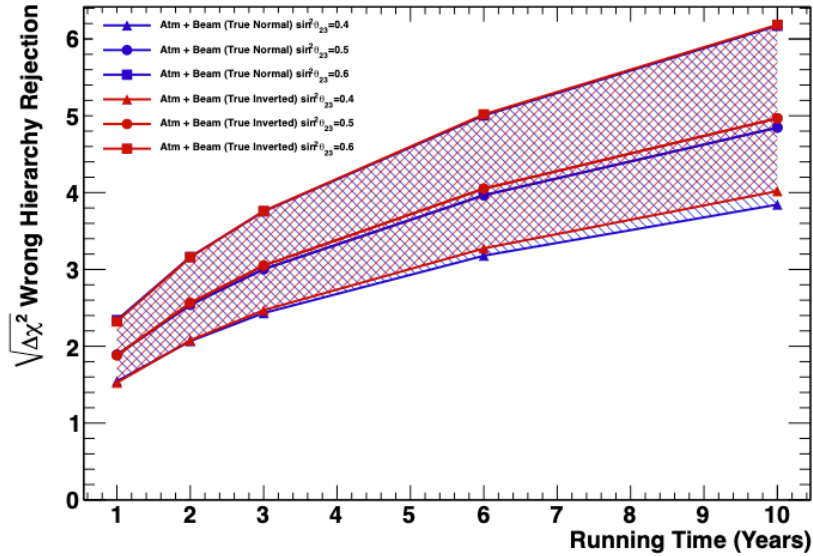

Figure 9: Neutrino mass hierarchy sensitivity as a function of the true value of  $\sin^2\theta_{23}$ . In both figures the blue (red) band denotes the normal (inverted) hierarchy and the uncertainty from  $\delta_{CP}$  is shown by the width of the band.

- Hyper-Kamiokande will use the well-known Water Cherenkov technology and will profit from a well-understood and powerful Near Detector that will simplify early analyses;
- Hyper-Kamiokande will have the full target mass of 180 kt from the beginning while DUNE will reach the design target mass of 40 kt after a few years of running.

As an example, as stated above, Hyper-Kamiokande will observe CP violation at  $3\sigma$  after a few months and at  $5\sigma$  in two years for  $\delta_{CP} \sim -\pi/2$ , while DUNE will need an exposure of  $100 \text{ kt} \cdot \text{MW} \cdot \text{yr}$  and  $330 \text{ kt} \cdot \text{MW} \cdot \text{yr}$ , respectively. Assuming the staged scenario proposed by DUNE<sup>1</sup> such exposures will be reached after 2 years and 7 years respectively.

For larger exposures, the complementarities between DUNE and Hyper-Kamiokande will be important. For example, looking at the precision on  $\delta_{CP}$ , both experiments have similar precision even with a very different baseline, neutrino energy and detector technology. A combination or at least a cross-check and mutual validation will allow to help to disentangle oscillation parameters from systematics effects and improve the precision of the ultimate measurement of  $\delta_{CP}$ .

## 4 Technical contributions to Hyper-Kamiokande

The technical contributions envisioned by the French groups are described below. In addition to the ND280 detector upgrade, they consist in contributions to the electronics of the Hyper-Kamiokande far detector and the computing effort. The estimated costs are summarized in Table 1.

### 4.1 Far detector

#### 4.1.1 Overview of the French electronics contribution

The whole Hyper-Kamiokande electronics will be located in water-tight boxes under water, and attached to the PMT structure. **In order to maximize the visibility of the IN2P3 contribution, the LLR, LPNHE and OMEGA laboratories (+CEA) proposes to develop the whole data acquisition chain, from the PMT charge and time digitization to its sending to the data-processing units located outside of the detector.** Fig. 10 shows the overall arrangement of the under-water electronics. The French contributions to the electronics can be summarized in two main categories: the digitization and data encoding of the PMT charge and time (section 4.1.2) and the time

<sup>1</sup>20 kt and 1.2 MW beam the year 0, increased to 30 kt in year 1, to 40 kt in year 3 and to 2.4 MW beam in year 6

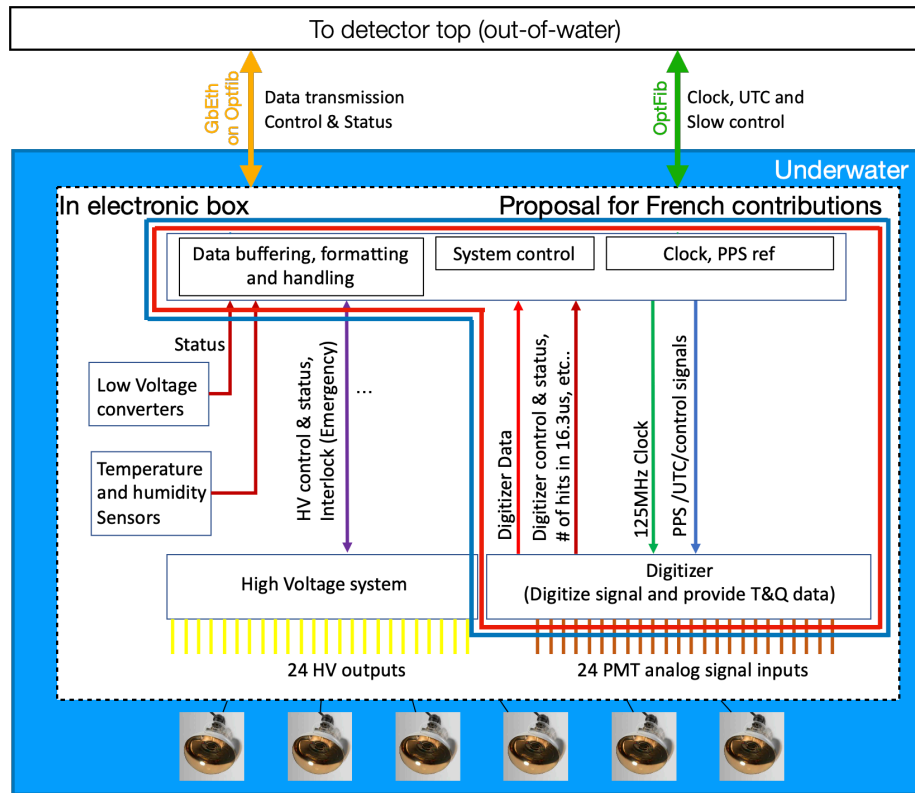

Figure 10: A front end electronics scheme with the functional blocks reported. The intended French contributions are surrounded with a tricolor box.

generation, distribution and electronics synchronization (section 4.1.3).

This project aims to tackle two major challenges:

- extract the full Hyper-Kamiokande potential, from a few MeV to a Multi-GeV energy range, without compromising the charge or time resolution, and
- have a very high reliability as its maintenance is likely to happen only once every 5-10 years.

The French proposal aims to fulfill these goals, while aiming also to:

- maximize its synergy with other projects and previous developments in electronics at CEA, LLR, LPNHE or OMEGA,
- maximize the synergies between our 4 laboratories, and
- maximize the visibility of the French contribution.

Item	Cost (M€)	Partially covered with external fundings	Funding approval	Construction period	Requested fundings (M€)
ND280 Upgrade	6	T2K Collaboration	2019	2019 – 2022	0.6 (obtained)
Far detector timing	1	ANR - INFN - CEA	2022	2023 – 2026	TBD
Communication cables	2	European countries	2022	2023 – 2026	TBD (~0.5)
Chip and Front-end	1.5-3	CEA	2022	2023 – 2026	TBD
Computing (CC-IN2P3)	1.9-3.8	-	2021	2021 – 2037	1.9-3.8
Total	12.4-15.8	-	-	-	~5-7

Table 1: Summary of the costs of the various items for Hyper-Kamiokande. Note that it includes only the production costs (the R&D costs has been already funded). See section 5 for more details about the over investments.

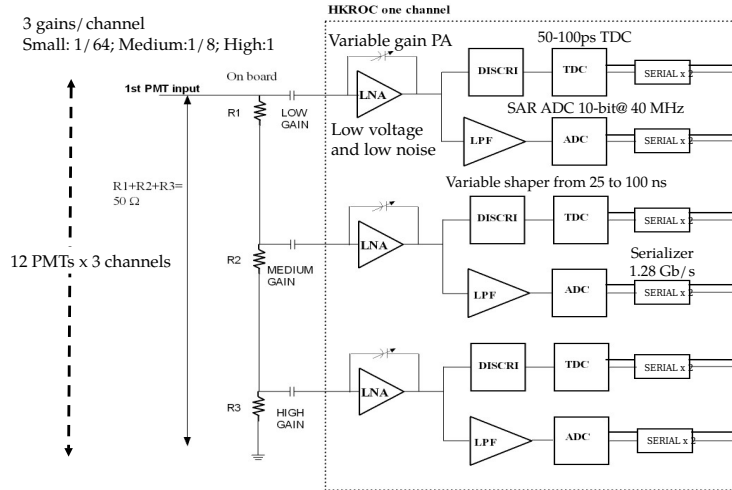

Figure 11: Schematic of the HKROC chip.

#### 4.1.2 Digitization

We propose to develop a digitization front-end board based on a new ASIC developed for the Hyper-K experiment: the HKROC. **Not only this chip is developed for Hyper-Kamiokande, but it is also designed to equip the future PMT-based experiments in the coming decade, by proposing a major upgrade compared to the current-generation CATIROC.** HKROC aims to combine the latest cutting-edge technology to adapt to Hyper-Kamiokande requirements and the advantages of an ASIC-solution: lower risk of failures, long-time durability, compactness, low power consumption. The Hyper-Kamiokande experiment requirements can be summarized briefly in:

- a large dynamic range (0-2500 pC) to cover the full extend of Hyper-Kamiokande MeV to multi-GeV physics. As a comparison, the dynamic range is ten times larger than the CATIROC chip. The charge linearity on this range should be within  $\pm 1\%$ .
- a time resolution  $< 300$  ps to be negligible compared to the internal PMT time resolution (2.6 ns).
- a deadtime  $< 1 \mu\text{s}$  in order to detect neutrinos coming from a close Supernova (such as Betelgeuse) with almost no information loss, but also to minimize the inefficiency to reflected or scattered light, or decay electrons. As a comparison the deadtime of the CATIROC is above  $3 \mu\text{s}$  from pure readout limitations.

The HKROC chip is developed by the OMEGA and CEA groups based on the existing HGCROC chip, which has been developed, tested and validated recently to equip the future CMS High-Granularity Calorimeter. The host board is developed by the LLR, based on the long experience of joint chip/board development with OMEGA on the HGCROC, the SPIROC (WAGASCI experiment) or the CITIROC (Super-FGD) for example.

The HKROC chip is etched in TSMC CMOS 130 nm, which allows to minimize the readout deadtime, reduce the electronic noise and cross-talk between channels compared to the AMS 350 nm in which the CATIROC chip has been etched. The schematic of the chip is shown in Figs. 11 and 12.

The analog part is composed of three “electronic channels” for one PMT output, coupled to a different resistance in order to provide high-, medium- and low-gain channels. For each electronic channel, the PMT output charge is amplified by a low-noise pre-amplifier which has a tunable gain, and passed through a shaper which stretch the signal time with tunable shaping time (15 ns to 25 ns) and correct for variations in the signal shape with the input charge. The simulation results confirm that such a layout allows to preserve a charge linearity below  $\pm 0.5\%$  in the whole 0 - 2500 pC range. In its current design, the HKROC allows to read-out 12 PMTs using 36 electronic channels. Each channel has an independent trigger which is fired when the signal is crossing an adjustable threshold value. When one channel is fired, all the channels attached to the same high-speed link are digitized (*i.e.* 3 PMT signals

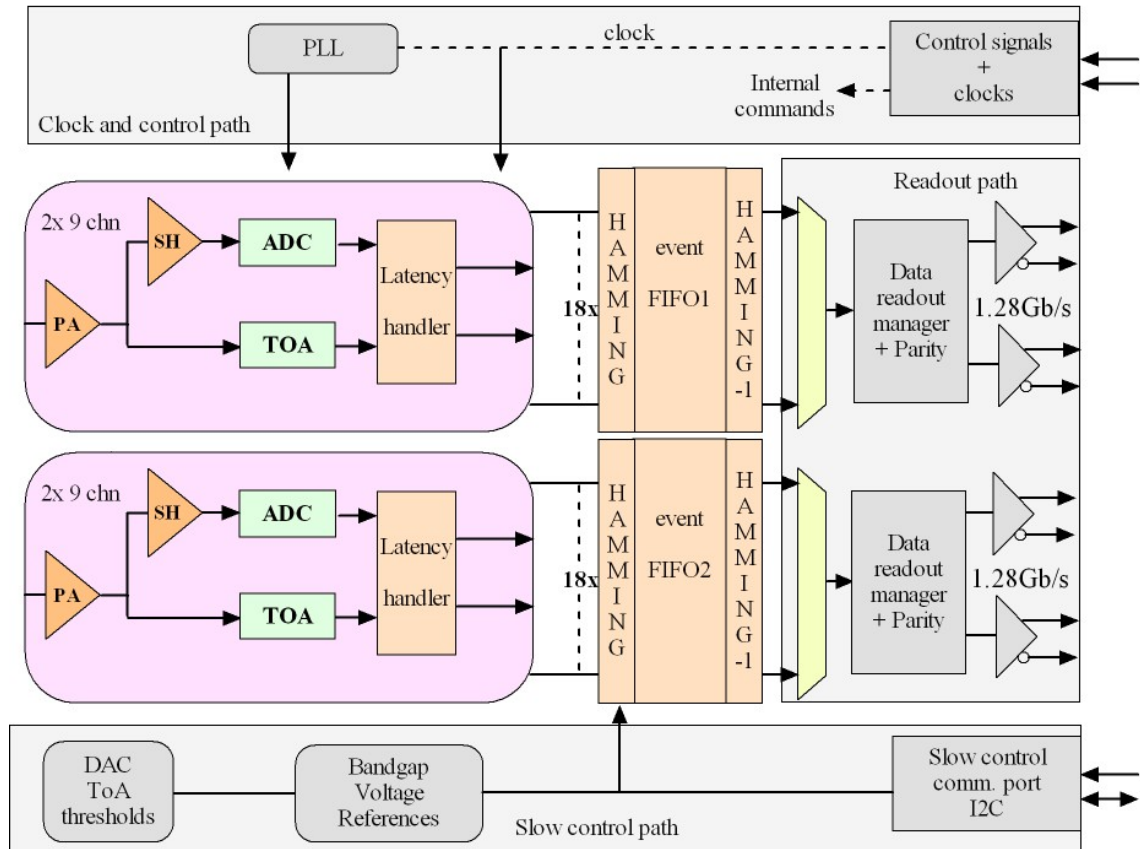

Figure 12: Layout of the HKROC chip.

in the current chip version).

For each trigger, the hit timing is provided by the combination of a coarse and fine time-stamp. The coarse time-stamp is common for all channels and is provided by the FPGA at 40 MHz. The fine time-stamp is provided for each channel independently using a 10 bits TDC developed by the CEA group. The combination of the two allows to reach a timing resolution better than 200 ps for the existing HGCROC chip, and similar performances are expected for HKROC.

The charge and fine time-stamp are digitized at 40 MHz using a 10 bits successive-Approximation ADC developed by the AGH-Krakow group. The ADC clock is asynchronous with the trigger time. The signal charge is not integrated; instead, the waveform is digitized by  $N$  sampling points separated by 25 ns, as illustrated in Fig. 13.  $N$  could be set by slow control to be 1, 3, 5 or 7. In the HGCROC and HKROC, 3 sampling points have been found to be enough to provide a linearity below 1% in the whole charge range.

Combined to the trigger time, it ensures an accurate charge measurement, but may be also used to detect possible waveform distortions. Finally, both charge and timing attached to the same serial link are read-out at 1.28 Gb/s and sent to a downstream FPGA. As a consequence of the digitization and read-out process, the chip is expected to have a deadtime smaller than 50 ns, compared to  $\sim 1 \mu\text{s}$  for the other digitizing solutions. Therefore, it may significantly improve detection of *e.g.* close Supernovae, reflected light or decay electron. The expected performances of the HKROC has been listed in Table 2. In comparison with the other digitizer solutions (QTC from Japan and discrete solution in Italy), the HKROC is expected to have:

- significantly reduced deadtime of 50 ns, compared to 500 ns to  $1 \mu\text{s}$  in other solutions.
- a reduced noise compared to discrete solution, and similar noise to QTC, which is essential for low energy physics.
- the possibility to partly use the waveform to discriminate between some dark rate and signal events.

Item	
Number of input per chip	12 PMT $\times$ 3 channels
Trigger	self trigger with constant threshold
Threshold	$\sim -0.3$ mV ( $<1/10$ pe)
Dynamic range	0.2~2500 pC with 3 ranges (ratio 1:8:64)
Dead time	$<50$ ns
Charge Resolution	$\sim 0.15$ pC (to-be-refined)
Charge (Non-)Linearity	$< +0.5\%$
Timing Resolution	0.2 ns ( $-3$ mV $\sim 1$ pe)
Power dissipation	50 mW
Process	0.130 $\mu$ m TSMC CMOS process
Failure rate (ch)	To-be-studied

Table 2: HKROC specification.

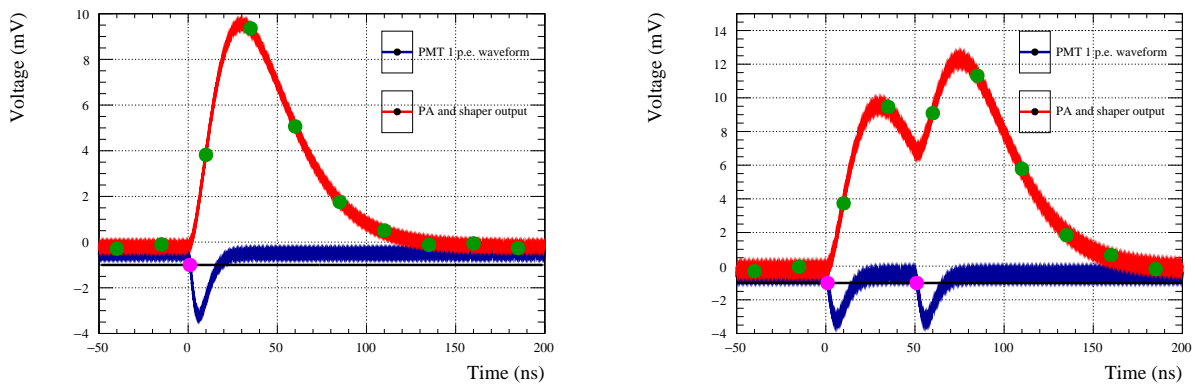

Figure 13: Schematic showing the PMT waveform (blue), shaper output (red), the time-of-arrival (magenta) and the other digitized points (green). Left shows case where a single PMT signal happens, in which case the trigger timing as well as the following 3 to 5 points are digitized. The right figures when two time-close signals happen. Both trigger timing are registered, as well as the 2 first points after the first trigger, and the 3 to 5 points after the second trigger.

In a nutshell, the pros of the chip are the expected improved performances compared to other solutions, which allow to enlarge the Hyper-Kamiokande physics. However, the other solutions already have some working prototypes, and are therefore much more advanced on their development.

The HKROC digitizer board is developed by the LLR, based on similar boards used for the HGCROC readout. All HKROC digitizer board will be driven by the same clock system running at 125 MHz and synchronized by a beacon allowing the time-stamping of the events. These signals come from the master clock and control board. The board will use the 125 MHz clock to generate a 40 MHz clock which will be distributed to the chip to determine the ADC frequency. Each board will be equipped by 2 HKROC chips in order to read-out 24 PMT outputs. The front-end will configure the whole chip through an I<sup>2</sup>C slave port, defining the channel trigger threshold, tuning the pre-amplifier gain etc. The digitized data from each HKROC are readout by 4 serial links to the Xilinx FPGA in order to cope with the large HK data rate. The FPGA will select only the triggered channel, reconstruct its charge based on the digitized waveform, and send the charge and timing to the DAQ.

The timeline for the R&D and the whole project schedule are shown in Fig 14. The HKROC is now being etched, and the LLR and OMEGA are in close collaboration so the first results could be produced in November. **It should be noted that the timeline is extremely tight, as the digitizer decision will happen over the Summer 2022.** This review will take three items into consideration:

- the ability of the electronics to reach Hyper-Kamiokande performances,





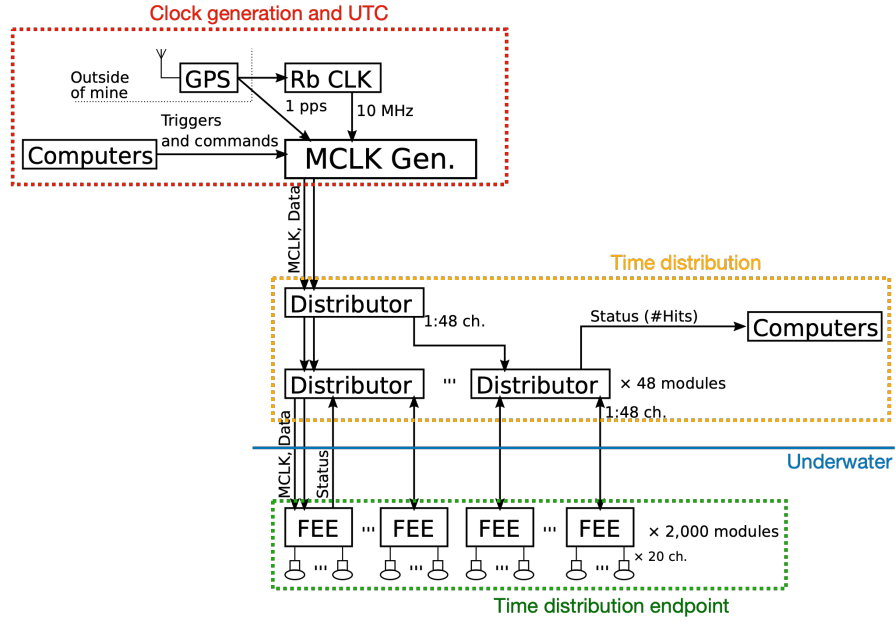

Figure 15: The timing and auxiliary transfer design overview. The three main sub-parts for this system are represented into dashed-line boxes.

produce a 125 MHz output. This frequency is then distributed over different “branches” by means of Time Distribution Modules (TDM) and delivered to all the “leaves” represented by the FE modules using the so-called Time Distribution Endpoints (TDE). The PPS and the 10 MHz signals, along with information about the detected satellites, reach also a computer infrastructure to form the UTC time synchronous with the local time base and, from there, propagated to all the elements in the form of data packets to the DAQ system. These elements would allow to produce an implementation of the UTC at Kamioka called “UTC(HK)” with which all the events detected at HK could be time-stamped.

**Clock generation and UTC.** The base clock represents the foundation of the cadence delivered to all the detector electronics elements; therefore it must be very stable and precise to guarantee, at each end-point, a signal that still meets all the requirements in spite of the deterioration due to the distribution process. To achieve this goal many elements must work together as shown in the block scheme of Fig. 15.

The cadence generator technology that guarantees the best performance is the atomic clocks, but, currently on the market there is a vast range of instruments with different noise levels, stability characteristics and prices. The technologies selected and proposed for Hyper-Kamiokande are the Passive Hydrogen Maser (PHM) (microwave amplification by stimulated emission for radiation) and the Rubidium (Rb) standard which can provide a 10 MHz clock and a PPS with characteristics summarized in Table 4<sup>2</sup>. The frequency that has been selected as main front-end electronics clock is 125 MHz then, such a cadence has to be generated starting from the atomic clock signals. The frequency synthesis must be performed limiting as much as possible any additional jitter and keeping the reference with the PPS and the UTC. The current plan is to design a custom board which will be equipped with a stable

<sup>2</sup>The Passive Hydrogen Maser also provides a 100 MHz clock output.

Time Synchronization Experimental Constraints	
Total Jitter	$\leq 100$ ps
Board to Board skew	fixed over any reset and power cycle
Accuracy to UTC	$\leq 50$ ns
Critical Slow-Control Data bandwidth	$\geq 100$ Mbps

Table 3: Current experimental requirements for the time distribution and synchronization system.

1 GHz oscillator and a Phase-Locked Loop (PLL) used to condition this frequency with the 10 MHz signal coming from the atomic clocks. The PLL output will then be a 1 GHz clock with one edge every hundred aligned with the one coming from the atomic clock which is in turn aligned with the PPS. A clock divider will then be used to provide the final 125 MHz frequency and a set of fan-out buffer chips will provide the signals for all the TDMs. The board is still under design at this stage and more details will be provided after construction and characterization.

**Time distribution system.** Once a stable and precise local time base has been generated, its output cadence has to be distributed to all the front-end modules of the HK detector. Also in this case, a research on the best technologies available to perform the task has been carried out and the two solutions listed below have been selected:

- **Custom solution:** the clock is embedded in a custom data link and distributed by means of a custom design protocol that guarantees a very low jitter characteristics and a bandwidth adapted to the experiment’s needs.
- **White Rabbit solution:** The clock and data are distributed together over one bidirectional link where the CERN White Rabbit protocol [12] is implemented. This protocol guarantees a precise time distribution and board to board skew compensation.

**At the end of a R&D phase evaluating both solutions, it was concluded that the custom solution is more relevant for the Hyper-Kamiokande experiment.** We describe the main features of the custom solution below.

For the custom solution each TDM is designed to perform the following tasks:

- Receive the precise clock from the time generation system and distribute it embedded into data with a jitter at the endpoint smaller than experimental requirement.
- Guarantee a constant channel to channel phase difference over each reset and power up.
- Guarantee a bidirectional data bandwidth of at least 100 Mbps (at net of the data encoding).

The custom solution relies on the Clock and Data Recovery (CDR) technology which is the process of extracting time information (clock) and data from a single serial stream. The CDR is implemented by means of a specific serializer-deserializer (ser-des) couple to be used on both sides of the link. The simplicity, reliability and the convenience of this technique has fueled its use in many different fields so that all the modern FPGAs have CDR compliant ser-des already embedded on the silicon. This represents a further advantage for the experiment because it is possible to send slow-control data and distribute the system clock using one single fiber. It doesn’t require any dedicated chip-set beside the FPGA already used to perform all the digital operations needed for the data collection and communication with the DAQ. Reducing the components on the electronics boards has advantages on many critical aspects of the HK’s design like the in-water electronics footprint, its power dissipation and the number of links and connectors between the design entities. In this scheme represented in Fig. 15, the precise clock is received by a distributor called “master”, which has a CDR compliant link to each “slave” distributor. Each TDM is also connected to a computing system using a standard Ethernet link to exchange slow-control information, like the upload firmware for the FE FPGAs or the acquisition related commands, and pass them to all the front-end modules connected to it. A non-deterministic channel from the in-water electronics to the TDM is also established and is used to send housekeeping information and slow-control data to the DAQ.

Technology	Passive Hydrogen Maser	Rubidium
Frequency stability	$\sim 5 \times 10^{-13}$ @ 1 s	$\sim 2 \times 10^{-11}$ @ 1 s
Equivalent jitter	0.5 ps	2 ps
Frequency drift	$\sim 5 \times 10^{-15}$ @ 1 day	$\sim 1.6 \times 10^{-12}$ @ 1 day

Table 4: Passive Hydrogen Maser and Rubidium atomic clock characteristics.

**Time Distribution Endpoint.** The TDE is the entity integrated in the front-end electronics that receives the data stream from the Time Distribution Module, reconstructs the clock embedded, cleans it by means of a PLL and provides it to all the logic elements that need it. A FE general block scheme that reports all the logic elements is depicted in Fig. 10.

From a hardware point of view the TDE needs an optical transceiver to establish the connection over the optical fiber, an FPGA with the corresponding ser-des to extract the clock, and a PLL to eventually clean the jitter. Even though the exact number of sensors to be read and its routing schemes are not completely defined, the TDE will be equipped with enough ports to handle environmental sensors and convey the information on the data transmission link.

**Expected work share between French labs.** Over the last months a strong collaboration between the LPNHE and IRFU groups has been established for the development of the time distribution system for HK. The technique of the clock and data recovery has been chosen as a baseline solution for the clock distribution protocol. Other possible solutions are also being studied. A hardware developed by IRFU engineers will be adopted to be used as a TDM in the time distribution scheme proposed by LPNHE-INFN(Rome) team. The corresponding prototypes will be developed in time for the collaboration review in Summer 2022 (see Fig. 16 for more details about the expected schedule).

Year Month	2022					2023					2024					2025													
	Jul	Aug	Sep	Oct	Nov	Dec	Jan	Feb	Mar	Apr	May	Jun	Jul	Aug	Sep	Oct	Nov	Dec	Jan	Feb	Mar	Apr	May	Jun	Jul	Aug	Sep	Oct	Nov
Circuit boards design & test																													
Prototype design (#1)																													
Prototype #1 production																													
Prototype #1 test																													
Prototype design revision (#2)																													
Prototype #2 production																													
Prototype #2 test																													
Final prototype design																													
Final prototype production																													
Final prototype test																													
Design finalization for production																													
Pre-production																													
Pre-prod. Module test																													
Circuit boards Mass production + QC + Component test																													
Contract + Procurement																													
Production + QC (top, 140 modules)																													
Production + QC (barrel #1, 280 modules)																													
Production + QC (barrel #2, 280 modules)																													
Production + QC (bottom, 140 modules)																													

Figure 16: Expected schedule for the design, tests, approval and construction of the time synchronization system for the Hyper-Kamiokande far detector.

## 4.2 Computing

**As computing is an important element for the success of these experiments and CC-IN2P3 is playing a key-role for LHC and many other experiments, a French contribution to the T2K and Hyper-Kamiokande computing effort seems natural and desirable.**

During the construction and exploitation of the detector suite, several simulations will produce data that will need storage. Starting from 2027, data files will also be produced by these detectors. Because of the size of the detector and the number of detectors, the Hyper-Kamiokande far detector will produce a significant fraction of data that will need to be stored and processed. It doesn't seem feasible to store and process all the produced data into one single site (e.g. at the Kamioka site as it is the case for Super-Kamiokande).

For these reasons, we propose to use the computing resources of the CC-IN2P3 as part of T2K and Hyper-Kamiokande experiments computing schemes. Such proposal was initiated with the IN2P3 directorate and a more detailed proposal was submitted in November 2020.

**T2K and Hyper-Kamiokande Computing Model.** Similarly to LHC, ND280 has used since 2010 a tiered system composed of three layers or *Tiers*. A T0 site is at KEK where the data are stored on HPSS/disk combo storage system. The raw data are transferred to RAL and Triumpf as T1 sites. An additional T1 site is highly desired by the collaboration. Data reconstruction and MC generation are run on T1 and T2 sites and then copied on at least one T1 site and one or more T2 sites. A set of python scripts and DIRAC utilities is used for data transfer and registration.

Hyper-Kamiokande also proposed to use a tiered computing model. Data collected by the detectors in Japan are stored in the two T0 sites (Kamioka and KEK) and copied to T1 sites after reduction. Data calibration and reconstruction along with Monte Carlo simulations will be performed at T1 and T2 sites. Data and workload management between sites is done using the DIRAC (Distributed Infrastructure with Remote Agent Control) framework [13]. T2 sites should have enough computing and storage resources to process and store part of these data or produce events simulation and reconstruction.

**In this scheme, we propose to include CC-IN2P3 as a T1 site, that will therefore store part of data produced by T2K and Hyper-Kamiokande.** More precisely, it will:

- host data and contribute to the simulation and analysis productions of the T2K experiment until the end of its data taking campaign in 2026,
- contribute to the simulation effort (data storage and computing) for the Hyper-Kamiokande construction era (until 2027),
- and host data and contribute to the simulation and analysis productions of the Hyper-Kamiokande starting 2027 and for at least 10 years.

This last point can be decomposed into two scenarii:

**Scenario 1:** Hosting ND280 and INGRID data, or

**Scenario 2:** Hosting all near detectors data a.k.a. INGRID, ND280, IWCD, and the far detector.

In these scenarii, T1 sites are not expected to have duplicate copies of each file as this would result in a major storage space request. Rather, it is expected that at least two T1 sites will host single copies of each data and simulation file for one or several detectors.

Tables 5 and 6 present the expected resources needed during the construction and data taking phases. In scenario 2 (data from all detectors stored at CC-IN2P3), the amount of produced data (raw, processed and MC) will be about 28.6 PB at the end of the 10-years data taking period.

These scenarii have different timescales of implementation which allow us to start ramping up efforts as experimental phases evolve. Moreover it is possible later to decide to increase our involvement into the overall computing effort, keeping in mind that a strong involvement at the present will make us more visible within both the T2K and Hyper-Kamiokande collaborations. Let us emphasize the fact that these scenarii are based on our current estimations of the needed computing and storage described earlier. **Since the request is stretching over 17 years, it is expected that we will need to**

Detector	MC (HS06 CPU.h)	MC Storage (TB)
INGRID	0.13M	7
ND280	19.2M	2,250
IWCD	97M	52
Far detector	20M	500
Total	136.33M	2,824

Table 5: Expected computing resources for the Hyper-Kamiokande experiment during the construction phase, considering only one copy of each file. Table taken from [14].

Detector	Data Storage (TB)	MC (HS06 CPU.h)	MC Storage (TB)
INGRID	226	0.51M	26
ND280	669	42.2M	4,950
IWCD	620	684M	367
Far detector	18,440	25M	500
Total	19,955	751.71M	5,858

Table 6: Expected computing resources for the Hyper-Kamiokande experiment during the data taking phase, considering only one copy of each file. Table taken from [14].

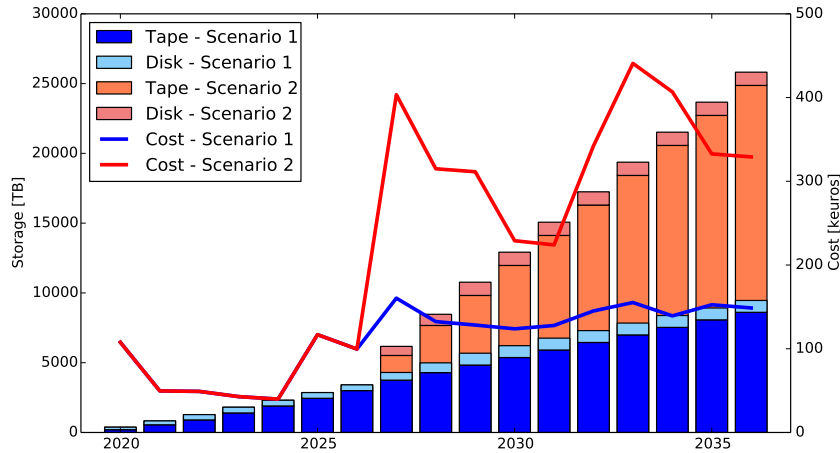

Figure 17: Time profile of the requested storage and associated costs. The blue items correspond to Scenario 1, while the red ones correspond to Scenario 2.

**reevaluate these every couple of years, but our current and rather conservative estimations should not significantly change with these reevaluations.**

The costs estimation for each scenario are represented in Fig. 17 under this assumption (no replication of files within the same site). It is likely that the cost will go down, as new storage technologies will appear reducing the hardware cost.

**Let's point out that there is a clear desire from the collaboration point-of-view, and especially the non-Japanese contributors, to include the cost of the computing before and during data taking as part of the construction costs of the Hyper-Kamiokande experiment.**

**Hosting collaboration database infrastructure.** Another possible French contribution using CC-IN2P3 to the Hyper-Kamiokande collaboration is the hosting of the database containing all the information related to the collaboration management, experimental conditions and operations. For instance, this database will contain shifts schedule, publications details, detector calibrations and documentation. Based on the work made by the KM3NET collaboration and also hosted at CC-IN2P3, the database would be accessed using a web interface hosted into a virtual machine at CC-IN2P3.

While R&D is ongoing to specify the requirements for Hyper-Kamiokande, overall costs are being evaluated, but should be negligible compared with the requested computing costs.

## 5 Experiment resources

In this section, the human, financial and organizational resources already acquired by the HK-France community are presented.

### 5.1 Human resources

Table 7 summarizes the permanent staff involved in the Hyper-Kamiokande experiment in the IN2P3 laboratories. The physicists involved in this experiment will bring their expertise acquired over the past 15 years in the Japanese neutrino program. LLR, IRFU, OMEGA and LPNHE have been collaborating on the T2K experiment on which the four labs are providing major hardware, software, and intellectual contributions. The groups have continuously held a central place in the construction, operation and analysis of the INGRID, ND280 and WAGASCI near detectors, the Super-Kamiokande far detector and the T2K oscillation analysis. In particular, the four groups are strongly collaborating on the construction of the upgraded ND280. The LLR and OMEGA laboratory have developed the WAGASCI and super-FGD front-end electronics, and the LPNHE and IRFU have collaborated on the development and production of the front-end electronics that will equip the High-Angle TPCs in the upgraded

ND280. Such collaboration continues in the development and integration of the detector responses and performances in the T2K official simulation, reconstruction and analysis tools.

Physicists from these laboratories, while continuing to contribute to the world leading results produced by T2K, T2K-II, and Super-Kamiokande, will gradually increase their contributions to the Hyper-Kamiokande experiment. This transition is expected to occur at different times depending on the responsibility of each one in the different experiments but we expect that, by the beginning of Hyper-Kamiokande the whole neutrino groups of LLR and LPNHE will be entirely committed to Hyper-Kamiokande.

As of today, physicists from French laboratories have already important responsibilities in Hyper-Kamiokande, being convener of the long-baseline group, of the Near Detector group, and of the electronics sub-working group in charge of the time synchronization system.

## 5.2 Financial resources

The involvement of France in the R&D for the Hyper-Kamiokande experiment is supported partially by the budget allocated to each group by the IN2P3 directorate. Also internal investments made by the CEA directorate allow contributions from the IRFU.

Moreover, other sources of fundings are helping and will help to develop the French contributions during the R&D and production phase. In particular, the Ecole Polytechnique has invested 400 k€ into the development of the HKROC chip for the under-water front-end electronics. In addition, an ANR "BERTHA" was recently awarded to LPNHE Neutrino group. This funding will cover the R&D of the time generation and clock distributions systems for the Hyper-Kamiokande far detector and contributions to Water Cherenkov Test Experiment. It will also cover a significant fraction of the time generation system cost.

## 5.3 Organizational supports

Organizational infrastructures are also contributing to the development of the French contributions to the Hyper-Kamiokande experiment. For example, a joint laboratory between the University of

Name	Position	Laboratory	Employer
Michel Gonin	DR	ILANCE	CNRS & University of Tokyo
Margherita Buizza-Avanzini	CR	LLR	CNRS
Olivier Drapier	DR	LLR	CNRS
Franck Gastaldi	IR	LLR	CNRS
Thomas Mueller	CR	LLR	CNRS
Jerome Nanni	IR	LLR	CNRS
Pascal Paganini	DR	LLR	CNRS
Benjamin Quilain	CR	LLR	CNRS
Alain Blondel	DR	LPNHE	CNRS
Jacques Dumarchez	DR	LPNHE	CNRS
Claudio Giganti	CR	LPNHE	CNRS
Mathieu Guigue	MCF	LPNHE	Sorbonne Université
Boris Popov	DR	LPNHE	CNRS
Stefano Russo	IC	LPNHE	CNRS
Vincent Voisin	IR	LPNHE	CNRS
Marco Zito	DR	LPNHE	CNRS
Stephane Callier	IR	OMEGA	CNRS
Selma Conforti	IR	OMEGA	CNRS
Frederic Dulucq	IR	OMEGA	CNRS
Ludovic Raux	IR	OMEGA	CNRS
Christophe de la Taille	IR	OMEGA	CNRS

Table 7: List of the permanent staff involved in the Hyper-Kamiokande experiment.

Tokyo and CNRS named “ILance” was recently established. The primary mission of this International Research Laboratory (IRL) is to develop strong collaborations between Japan and France on the Hyper-Kamiokande experiment, by facilitating researchers travel to Japan and the organization of joint workshops in Japan.

We also receive support from the France Japan Particle Physics Laboratory (FJPPL) which brings together Japanese and French researchers.

Finally, monthly meetings are organized with all the French groups involved in the Hyper-Kamiokande experiment in order to coordinate the national efforts.

## 6 Strength, weaknesses, and risks managements

In this document we present our analysis of the strengths, weaknesses, risks and opportunity of our proposed contributions to Hyper-Kamiokande.

### Strengths

- Hyper-Kamiokande will use the very well-known Water Cherenkov technology. Water Cherenkov detectors have proven to be exceptional detectors to study rare events in the MeV–GeV energy range thanks to the possibility of combining huge target masses and high-signal detection efficiency that allows to distinguish  $\nu_e$  from  $\nu_\mu$  (in LBL or atmospheric neutrinos) or to search for proton decays.
- Hyper-Kamiokande will use the neutrino beam and the near detector complex built for T2K, thus saving large amount of money for the long-baseline program. In addition the combination of well-understood (anti)neutrino beams (characterized using NA61/SHINE hadron production measurements) and near detectors will allow to reduce systematics uncertainties from the first day of the experiment. French groups have, since many years, leading roles in the operation of T2K Near Detector and in the corresponding reduction of systematics uncertainties.
- Construction budget for Hyper-Kamiokande have been allocated by Japanese government in 2019 with a budget profile that will allow to start the experiment in 2027. Given previous track records with similar projects in Japan, there is no doubts that budget will be allocated as expected.

### Weaknesses

- The groups from LLR and LPNHE are relatively small and physicists are already committed to the operation of T2K-II and Super-Kamiokande. This weakness is mitigated by the large overlap in terms of physics case, technologies and tools between the two collaborations (see for example the Near Detectors or the use of reconstruction techniques in water).
- So far no other IN2P3 groups decided to join the Hyper-Kamiokande experiment. We hope that the approval of Hyper-Kamiokande in Japan and its approval by IN2P3 Scientific Council will allow us to attract more physicists to the experiment.
- Hyper-Kamiokande is not yet considered as an IN2P3 project by the IN2P3 directorate. This clearly undermines our visibility within the collaboration and our possibilities to commit to the items on which we are doing ongoing R&D.

### Opportunities

- Hyper-Kamiokande has the great potential to be the first experiment to measure CP violation in the leptonic sector. No experiments before Hyper-Kamiokande have the sensitivity to measure CP violation at more than  $3\sigma$  and, once online, Hyper-Kamiokande will acquire statistics much faster than DUNE.



- The target mass of Hyper-Kamiokande will make it the most sensitive observatory for rare events in the MeV–GeV region. It will have, for example, the best sensitivity to proton decay and SN neutrinos.
- IN2P3 groups can build on their long standing expertise in the T2K experiment to propose strong contributions in Hyper-Kamiokande. The possibility of using chips developed by OMEGA for the Hyper-Kamiokande far detector is particularly attractive from this point of view.

## Risks

- One of the main identified risks is related to the dates for the approval and fundings of our proposed contributions to the HK electronics. In particular, the final choices on electronics will be made after the collaboration review which will happen in Summer 2022. This means that before that day, the IN2P3 Scientific Council should have provided an opinion about the feasibility of the proposed contributions and the IN2P3 directorate should have provided a general agreement about funding of these contributions to the HK electronics. **Missing the Summer 2022 deadline would compromise the French contributions to the Hyper-Kamiokande far detector.**
- If the solution proposed by our laboratories (digitizers developed by OMEGA and the clock distribution system) is not selected by the review or not funded by our funding agency, there are no other planned French contributions to the far detector construction and our contribution will be limited to the Near Detectors and to the computing. Since the HK constitution requires that all funding agencies must make some contribution to the construction of the far detector, this would put our participation to Hyper-Kamiokande in jeopardy.

## 7 Conclusions and requests to IN2P3

The Hyper-Kamiokande experiment is a next-generation LBL- $\nu$  experiment in Japan with a very rich physics program. In addition to providing world-leading constraints on CP violation in the leptonic sector and exquisite measurements of the neutrino oscillation parameters, it will be a multi-purpose rare events observatory for multi-messenger astrophysics and proton decay search with high discovery potential.

French physicists with a great expertise in this physics, thanks to their involvements in the T2K and SK experiments are proposing several hardware contributions to the far detector construction and computing efforts. These contributions exploit the great expertise and the tight collaboration established between the French groups.

With this document we ask the IN2P3 Scientific Council to evaluate the physics case of HK and the feasibility of the contributions proposed to the experiment by the IN2P3 groups. These contributions are in R&D phase but technological decisions will be taken by the collaboration in Summer 2022. An approval of the IN2P3 Scientific Council, followed by the recognition of HK as one of the IN2P3 projects, will maximize the chance that our proposed contributions will be approved by the collaboration, thus allowing IN2P3 groups to take important roles and responsibilities in the construction and operation of HK, followed by exciting physics analysis and results.

## References

- [1] Z. Maki, M. Nakagawa, et S. Sakata *Remarks on the Unified Model of Elementary Particles*, [Progress of Theoretical Physics](#) **28** (5), 870 (1962).
- [2] B. Pontecorvo, *Neutrino Experiments and the Problem of Conservation of Leptonic Charge*, *Sov. J. Exp. Theor. Phys.* **26**, 984 (1968).
- [3] Y. Fukuda, T. Hayakawa, et al., *Evidence for Oscillation of Atmospheric Neutrinos*, [Phys. Rev. Lett.](#) **81** (8), 1562 (1998).

- [4] SNO Collaboration, *Direct Evidence for Neutrino Flavor Transformation from Neutral-Current Interactions in the Sudbury Neutrino Observatory*, [Phys. Rev. Lett. \*\*89\*\* \(1\), 011301, arXiv:0204008 \[nucl-ex\]](#) (2002).
- [5] S. Dolan et al., *Sensitivity of the Upgraded T2K Near Detector to constrain neutrino and anti-neutrino interactions with no mesons in the final state by exploiting nucleon-lepton correlations*, [arXiv:2108.11779 \[hep-ex\]](#) (2021).
- [6] A. Takenaka et al. (Super-Kamiokande), *Search for proton decay via  $p \rightarrow e^+\pi^0$  and  $p \rightarrow \mu^+\pi^0$  with an enlarged fiducial volume in Super-Kamiokande I-IV*, [Phys. Rev. D \*\*102\*\* \(11\), 112011, arXiv:2010.16098 \[hep-ex\]](#) (2020).
- [7] A. Boyarintsev, A. D. Roeck, et al. (2021), *Demonstrating a single-block 3d-segmented plastic-scintillator detector*, [arXiv:2108.11897 \[physics.ins-det\]](#).
- [8] D. Collaboration, R. Acciarri, et al., *Long-baseline neutrino facility (lbnf) and deep underground neutrino experiment (dune) conceptual design report volume 2: The physics program for dune at lbnf*, [arXiv:1512.06148 \[physics.ins-det\]](#) (2016).
- [9] F. An, G. An, et al., *Neutrino physics with junos*, [Journal of Physics G: Nuclear and Particle Physics \*\*43\*\* \(3\), 030401](#) (2016).
- [10] H. Sekiya, *Supernova neutrinos in SK-gd and other experiments*, [Journal of Physics: Conference Series \*\*888\*\*, 012041](#) (2017).
- [11] A. A. Abud et al. (DUNE), *Low exposure long-baseline neutrino oscillation sensitivity of the DUNE experiment*, [arXiv:2109.01304 \[hep-ex\]](#) (2021).
- [12] White Rabbit Collaboration (2020), [White rabbit protocol official web page](#).
- [13] A. Tsaregorodtsev, M. Bargiotti, et al., *DIRAC: a community grid solution*, [Journal of Physics: Conference Series \*\*119\*\* \(6\), 062048](#) (2008).
- [14] IRFU/DPhP, LLR, et LPNHE (2020), *Computing proposal for the T2K and Hyper-Kamiokande experiments in Japan*, Tech. Rep.