

The Beam Test of a Separated Function RFQ Accelerator at Peking University

RFQ Group, PKU

State Key Lab. of Nuclear Physics & Technology, Peking University, Beijing 100871, China

Introduction In a traditional RFQ ions are accelerated and focused simultaneously by related field components generated by surface modulation of the quadrupole electrodes. Since a large part of the RF voltage is used for beam focusing, the accelerating efficiency is rather limited. While ions in a Separated Function RFQ (SFRFQ) are accelerated by fields between a series of gaps generated by diaphragm pairs loaded periodically onto the special pair of quadrupole electrodes and focused by the quadrupole field separately so that the overall accelerating efficiency is remarkably enhanced. In the following you will see the structure and merits of the SFRFQ comparing with the traditional RFQ.

Field and Structures of RFQ & SFRFQ

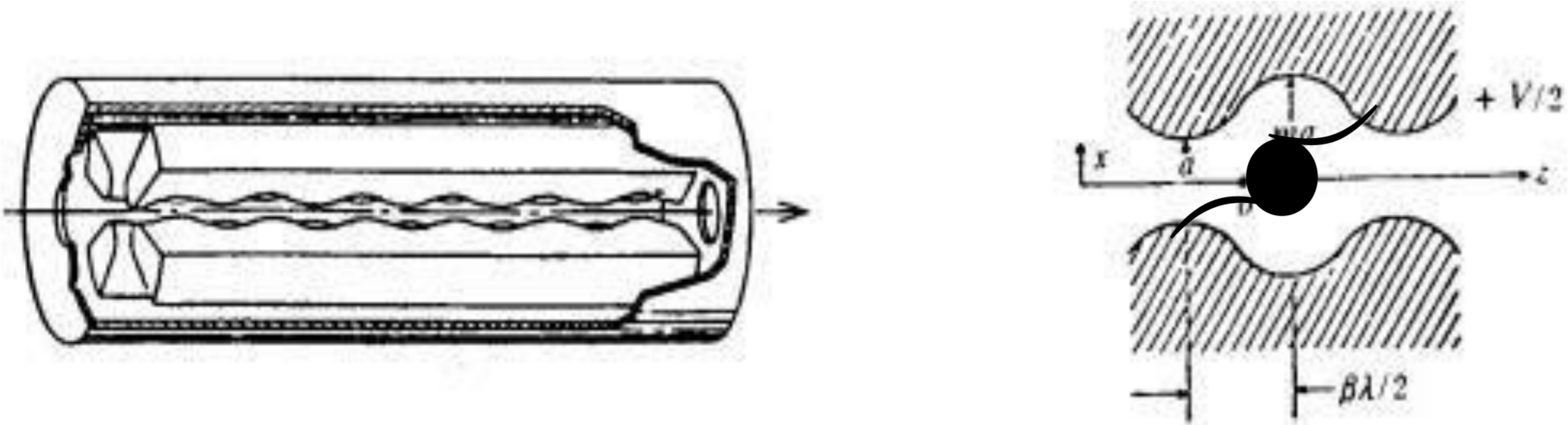

Fig 1: Schematic structure of conventional RFQ

For a conventional RFQ, we have

$$E_z = (kAV/2) \cdot I_0(kr) \cdot \sin kz \cdot \sin(\omega t + \phi) \quad (1)$$

$$E_r = [- (FV/a^2) \cdot r \cdot \cos(2\psi) - (kAV/2) \cdot I_1(kr) \cdot \cos kz] \cdot \sin(\omega t + \phi) \quad (2)$$

$$A = (m^2 - 1) / [m^2 \cdot I_0(ka) + I_0(mka)] \quad (3)$$

$$F = 1 - A \cdot I_0(ka) \quad (4)$$

V: accelerating voltage ; m: Depth of surface modulation

A : accelerating factor ; F : Focusing factor

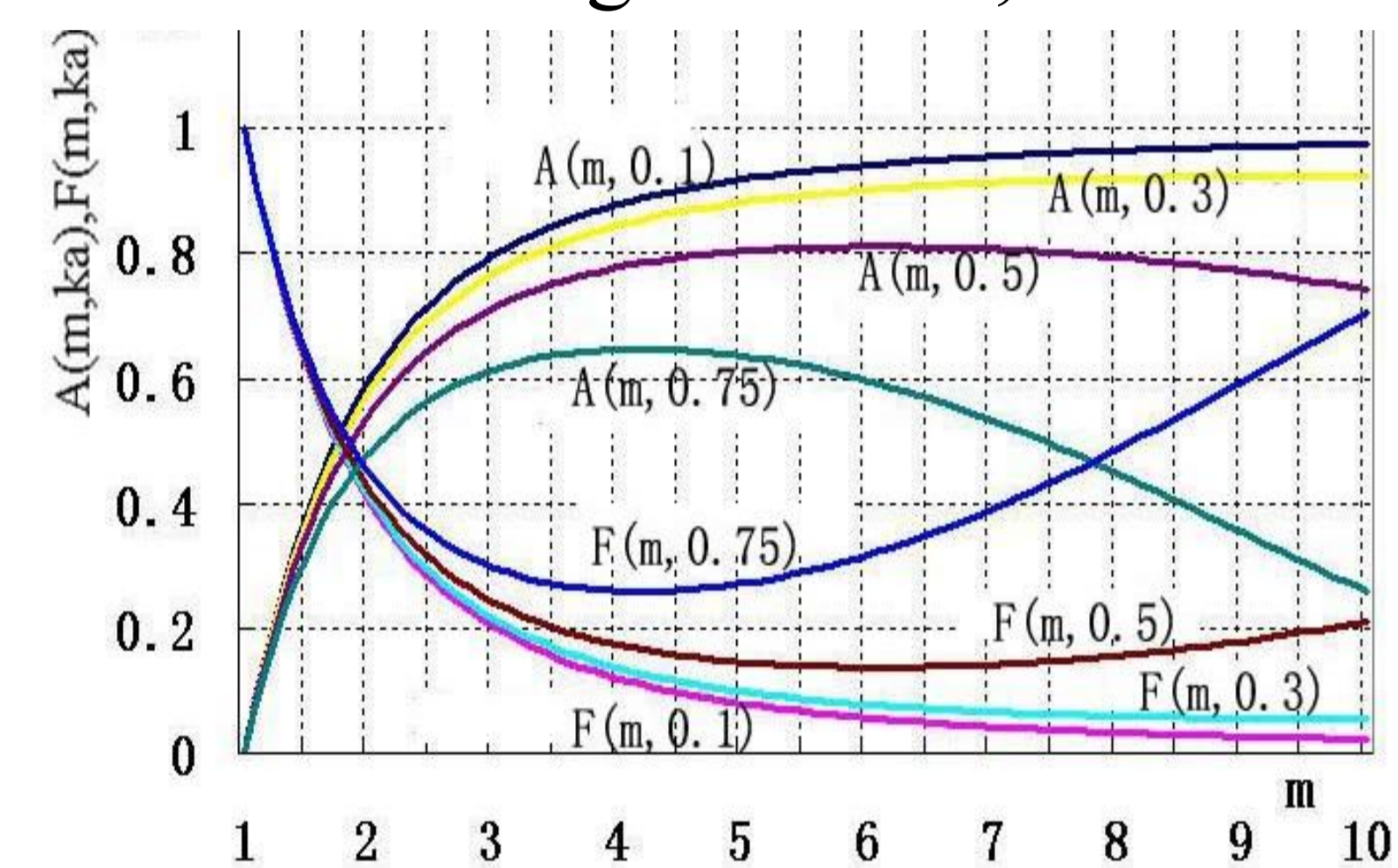

Fig 2: A & F versus m

The schematic structure of a SFRFQ is as in the fig.3, the accelerating field inside the diaphragms makes A=1, and time transit factor T~1. While in the quadrupole field, we have F=1. However, at the backside of a diaphragm, there is a field of deacceleration. In order to minimize this effect, we have to enhance alternatively the length of one diaphragm to nearly $\beta\lambda/4$ as can be seen in the figure 4.

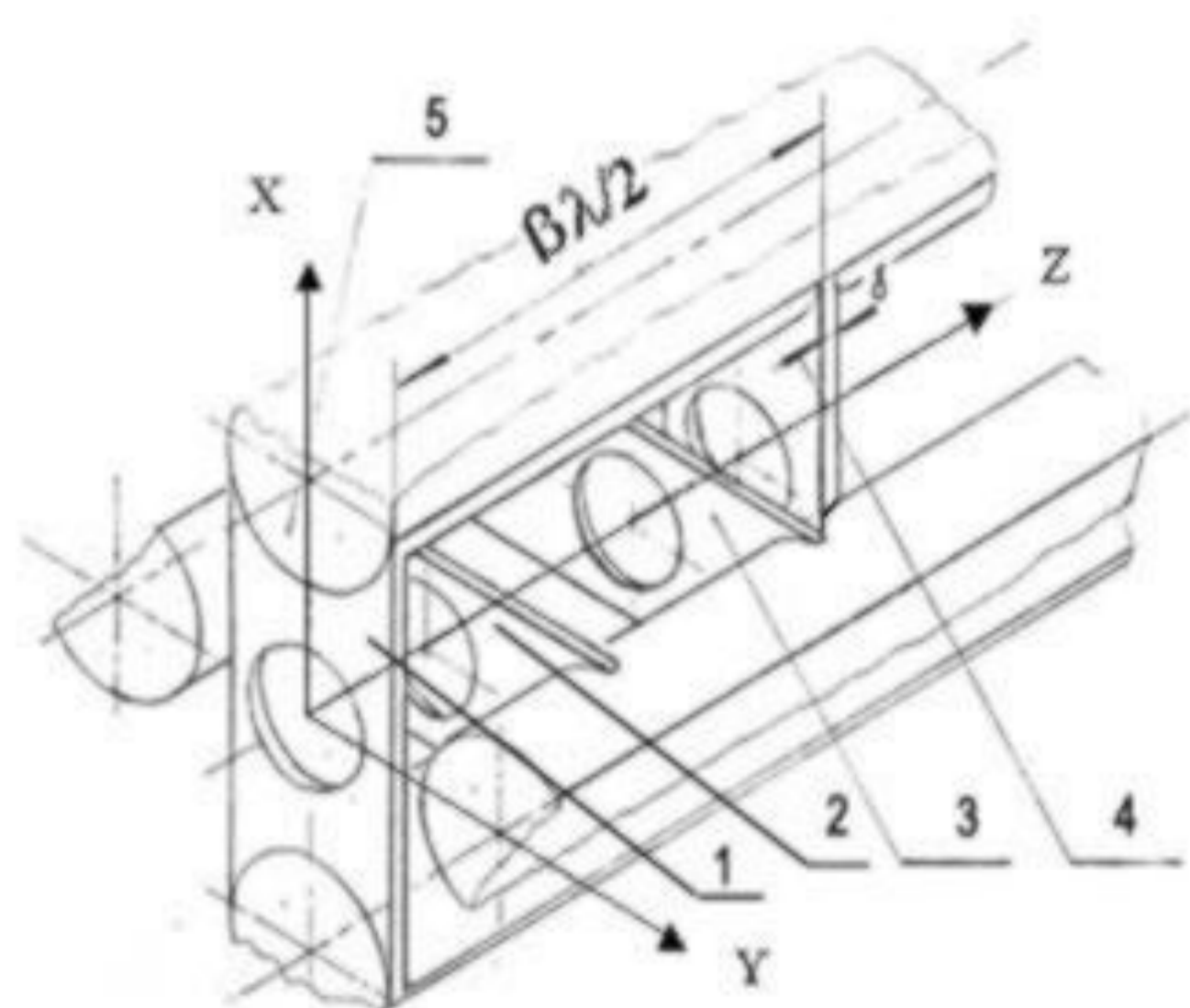

Fig 3: Diaphragms in SFRFQ

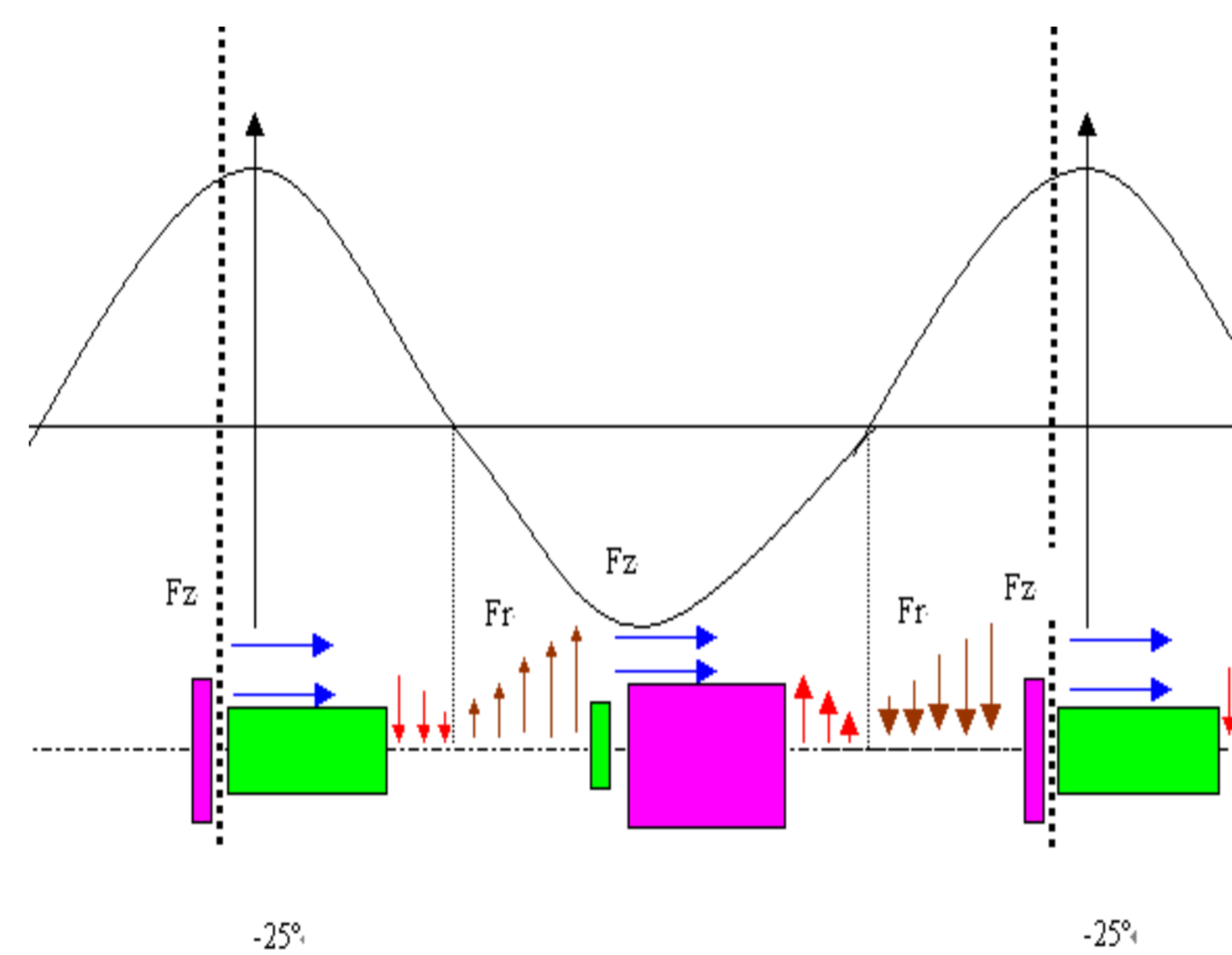

Fig 4: Asymmetry diaphragm system

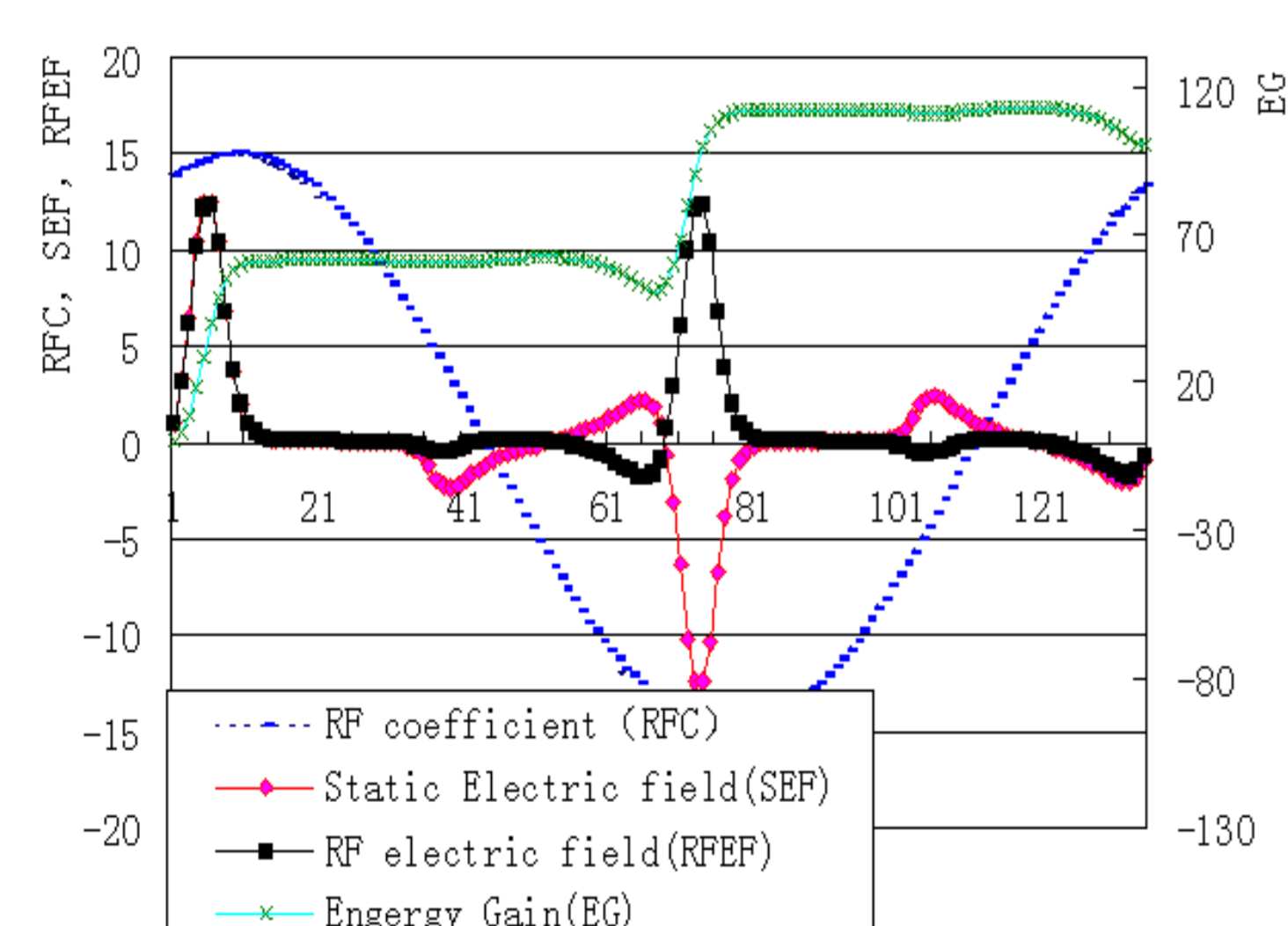

Fig. 5 Energy gain in SFRFQ



Fig.6 A SFRFQ model

The longitudinal field distribution & energy gain in such an asymmetry periodical diaphragm system and the practical structure model are shown in figures 5 & 6. To verify the feasibility and merits of this new idea, a code called SFRFQCODE was developed specially for SFRFQ cavity

design and beam dynamics simulation, which shows that for accelerating O^+ to 5 MeV for the same 1 MeV input energy and the same vane voltage of 70 KV of 26 MHz, the total length of a SFRFQ can be 80% shorter than that of a RFQ. (See table below).

	SFREQ	RFQ
Number of cells	82	132
Average energy gain (keV) per cell	48.8	30.3
Synchronous Phase	-25°	-25°
Resonator Length (m)	10.3	18.5
Beam aperture (mm)	6.2	6.2
Beam transport efficiency	96%	96%

Full Power Test of SFRFQ with O^+ Beam

To verify the feasibility of the SFRFQ structure, a prototype cavity of about ~1m long was constructed. It goes through full power test without beam and with O^+ beam injected at 1 MeV as following.

Input power(kW)	Vane voltage(kV)
16.2	65.81
20.7	73.16
23.4	78.06
28.8	86.22
33.3	91.02

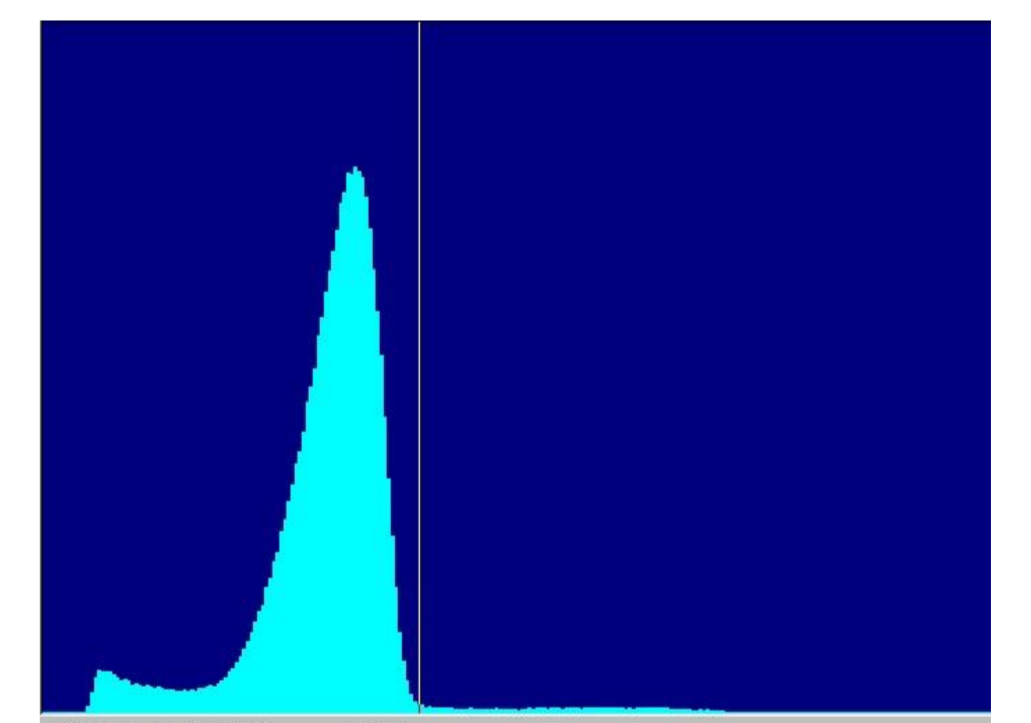

Fig. 7 X-ray spectrum of full power test with 26 MHz RF power source without beam

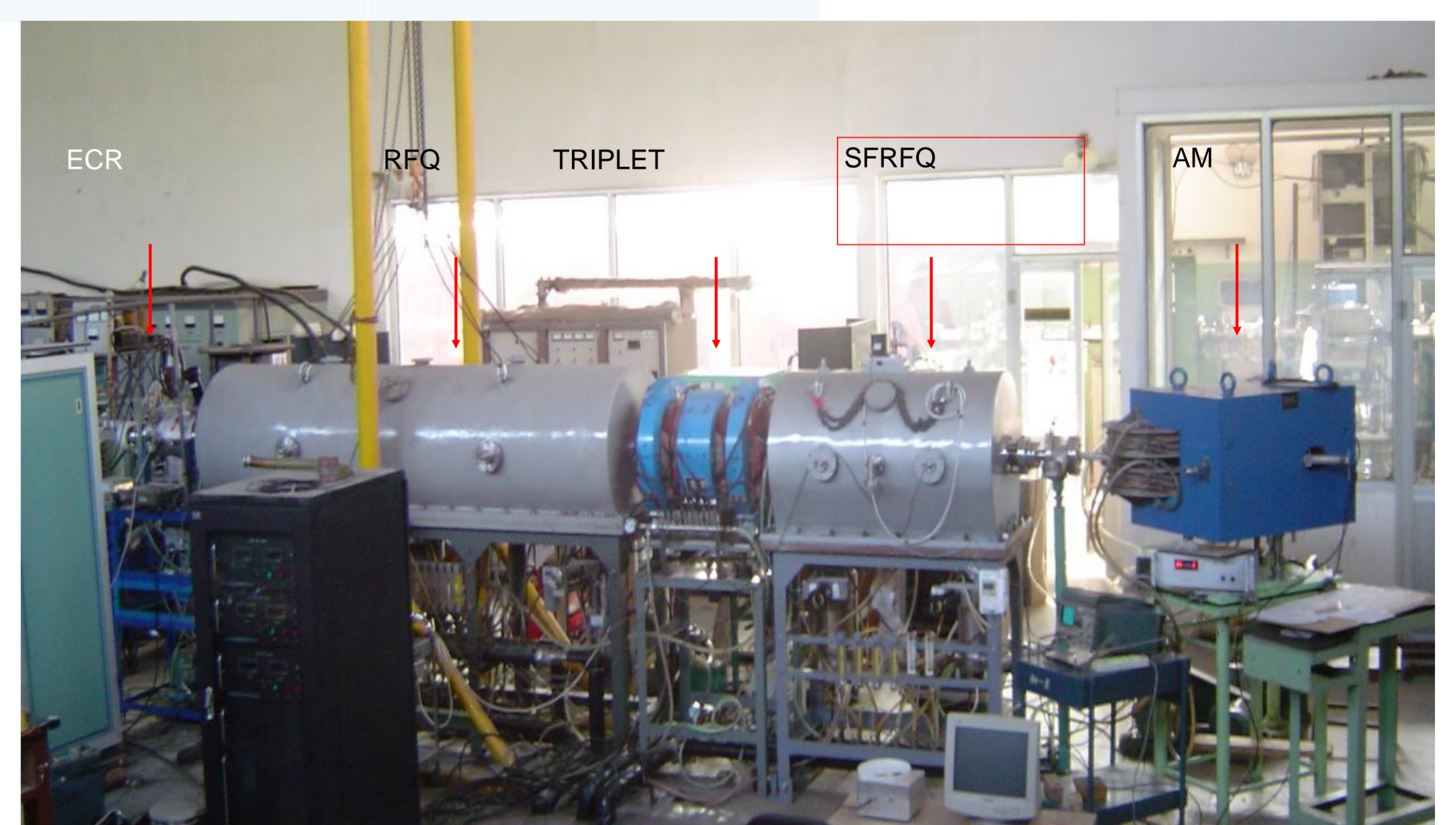

Fig. 8 The Layout of the SFRFQ beam test

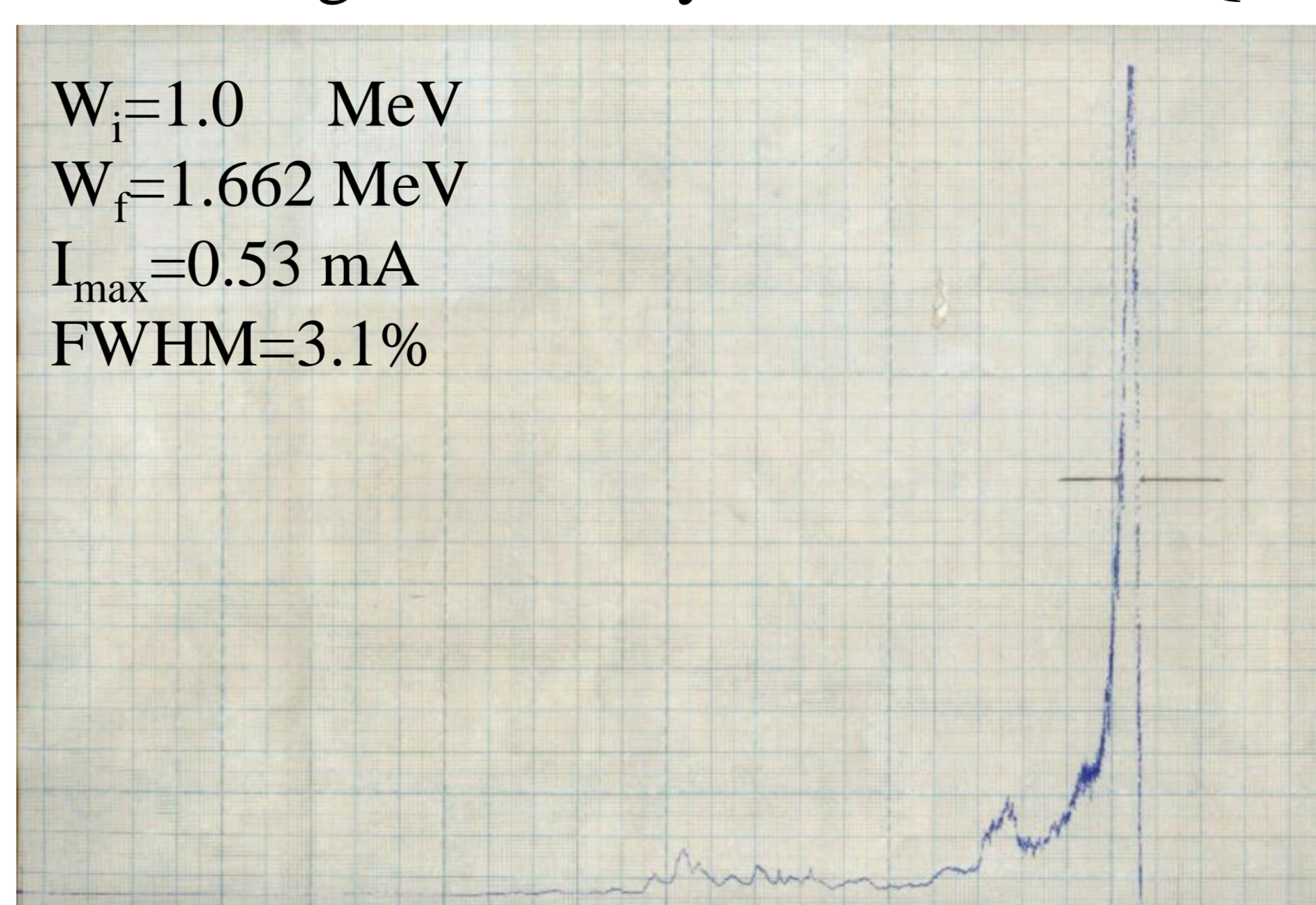

Fig. 9 Output Energy Spectrum of the O^+ beam

The result of the beam test shows the cavity length is 50% shorter than that of traditional RFQ even a part of the cavity is used for rebunching. The enhancement of accelerating efficiency for SFRFQ is proved.

$W_i = 1.0$ MeV
 $W_f = 1.662$ MeV
 $I_{max} = 0.53$ mA
 FWHM = 3.1%