



Optimized positron production in FCC-ee

Iryna Chaikovska, IJCLab/IN2P3/CNRS

on behalf of the WP3 team, the FCC-ee Injector update studies



Introduction (FCC-ee Injector Complex)

- e-/e+ linac up to 6 GeV, 1.54 GeV Damping Ring
- Pre-Booster Ring (SPS or new ring) (6 - 20GeV)
- Booster Ring (20 → 45 GeV)
- The main 6 GeV linac hosts the positron source. The positrons are produced with 4.46 GeV e-beam

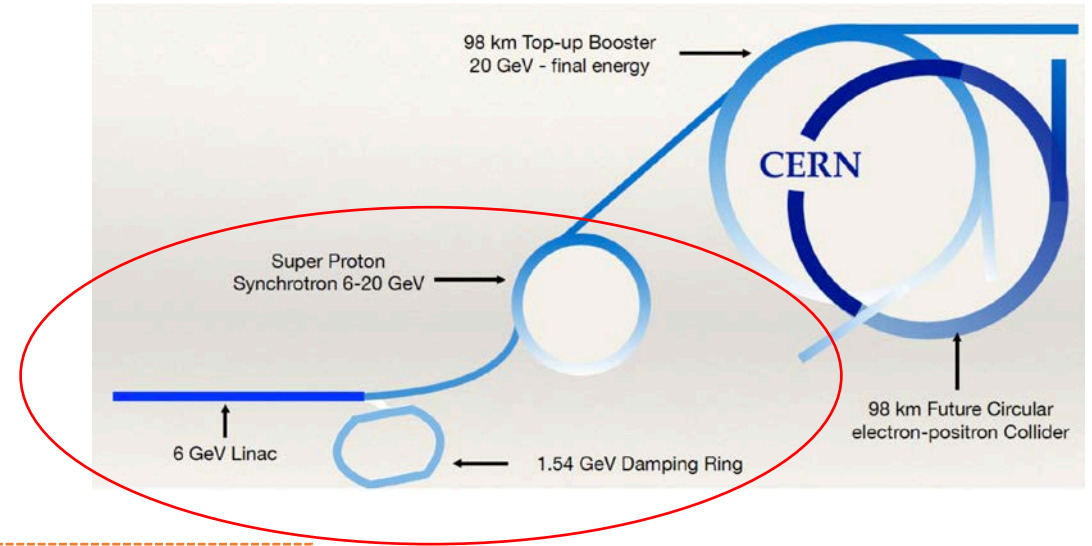

Baseline in CDR/Injector

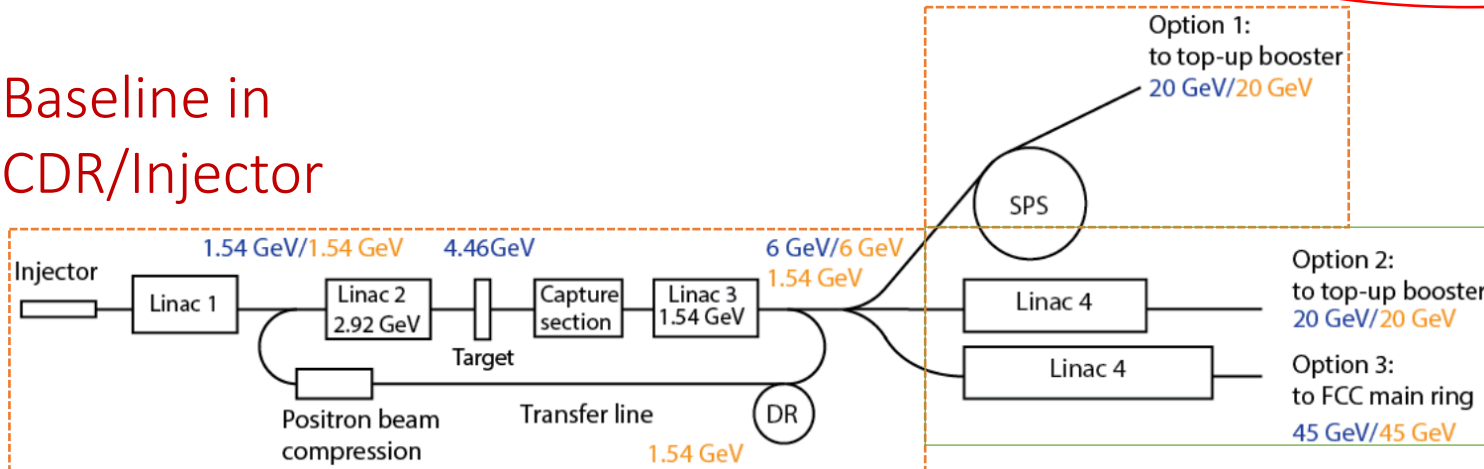

As alternative options for the FCC-ee Injector, a 20 GeV or a 40 GeV linacs are proposed to provide the direct injection into the main booster or main ring



FCC-ee Positron Source

The complete filling for Z running => Requirement @ DR $\sim 2.1 \times 10^{10}$ e⁺/bunch (3.5 nC)

$$N_{e^-/\text{bunch}} \times Y_{e^+/e^-} \geq 3.5 \text{ nC/bunch} \times 2$$

*A safety margin of 1.5 - 2 should be applied for the whole studies.

e⁺ production and capture section

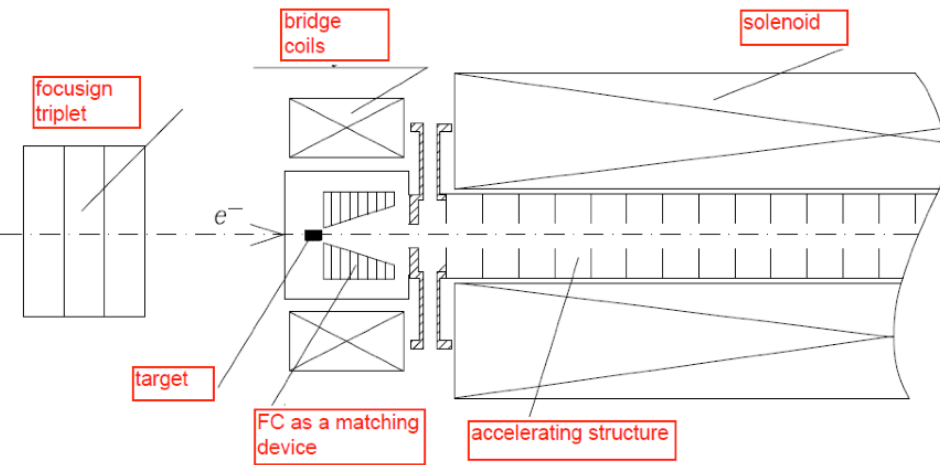

e⁺ acceleration up to DR energy (1.54 GeV)

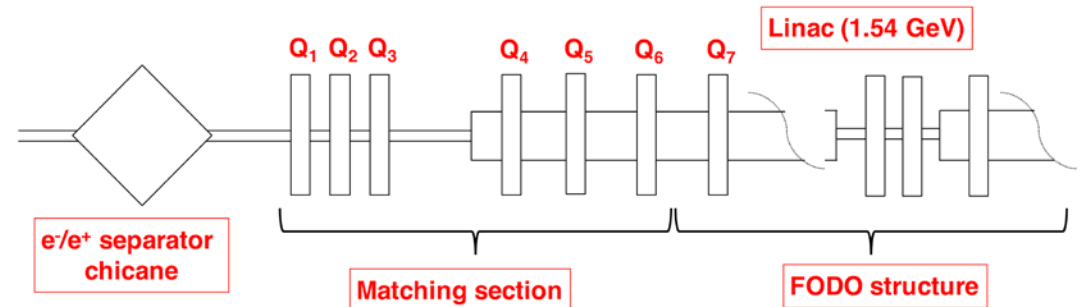



FCC-ee Positron Source: Schemes under Investigation

Production scheme:

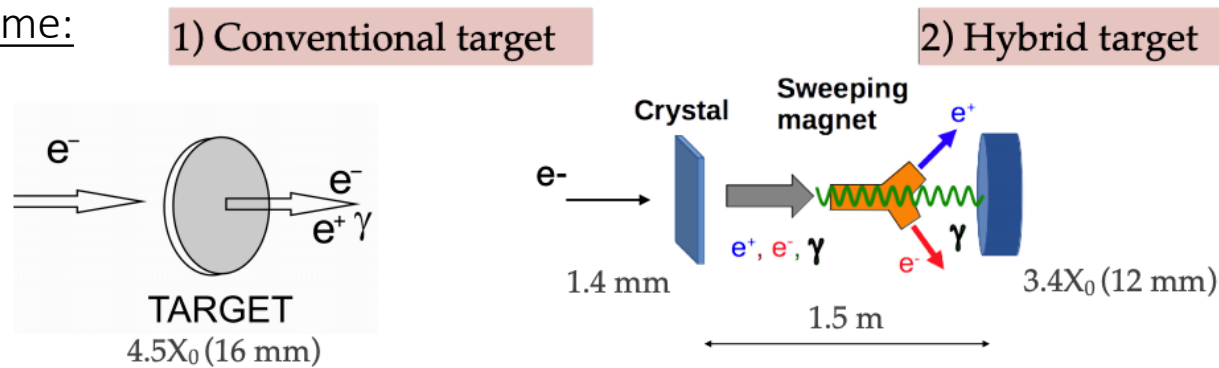

Capture system:

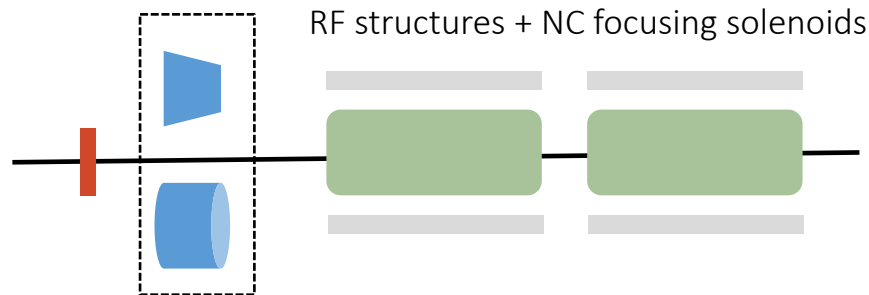

2 options to be considered for the Adiabatic Matching Device (AMD):

- Flux concentrator (pulsed magnet)
- Superconducting solenoid (new solution)

The capture linac is encapsulated inside the NC solenoid with the axial magnetic field of 0.7-0.8 T.

Options to be considered for the RF structures:
L-band (2 GHz) and large aperture S-band structures.



Flux Concentrator – FCC-ee Design (presently)

Goal: matching the e⁺ beam (with very large transverse divergence) to the acceptance of the capture linac.

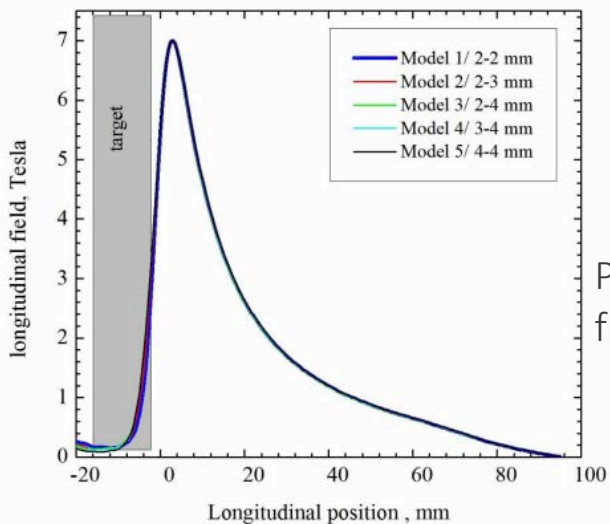
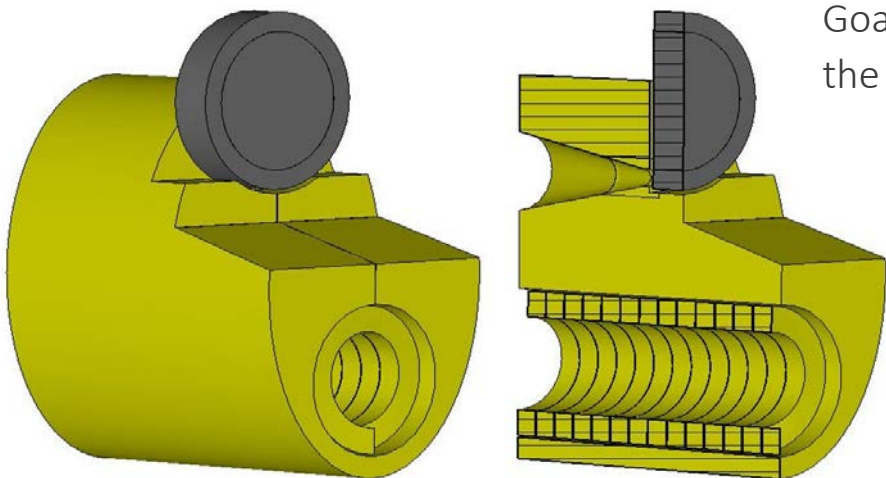

Peak of the magnetic field is at 5 mm from the target => field on target: ~3 T

Parameter [unit]	Value
Target diameter [mm]	90
Target thickness [mm]	15.8
Gap between target and FC [mm]	2
Grooving gap between target side face and FC body [mm]	2
Elliptical cylinder size [mm]	120×180
Total length [mm]	140
Conical part length [mm]	70
Min cone diameter [mm]	8
Maximm cone diameter [mm]	44
Cone angle [deg.]	25
Cylindrical hole diameter [mm]	70
Coil turns [-]	13
Current profile pulse length [μs]	25
Peak field [T]	7
Peak transverse field [mT]	135–157
Gap between coil turns [mm]	0.4
Gap between coil and FC body [mm]	1
Turns size	9.6×14 mm

Full 3D magnetic field map is used in the simulations

Courtesy of P. Martyshkin (BINP)



Positron Capture Section Design

Courtesy of P. Martyshkin

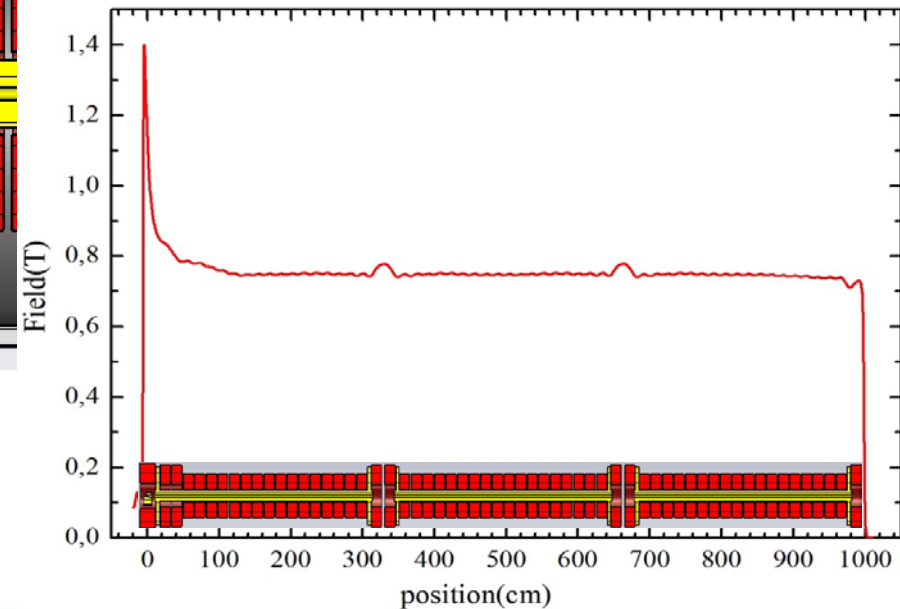
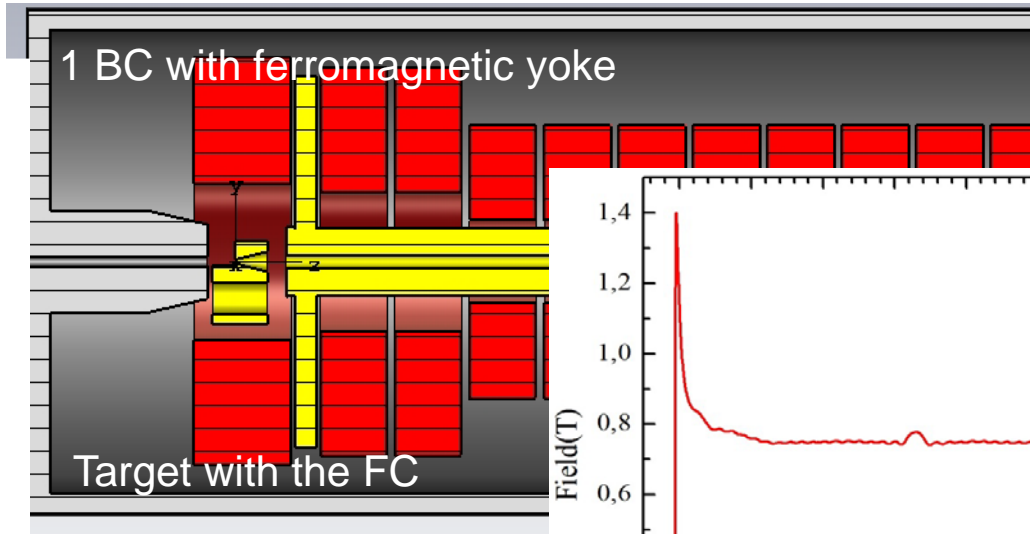
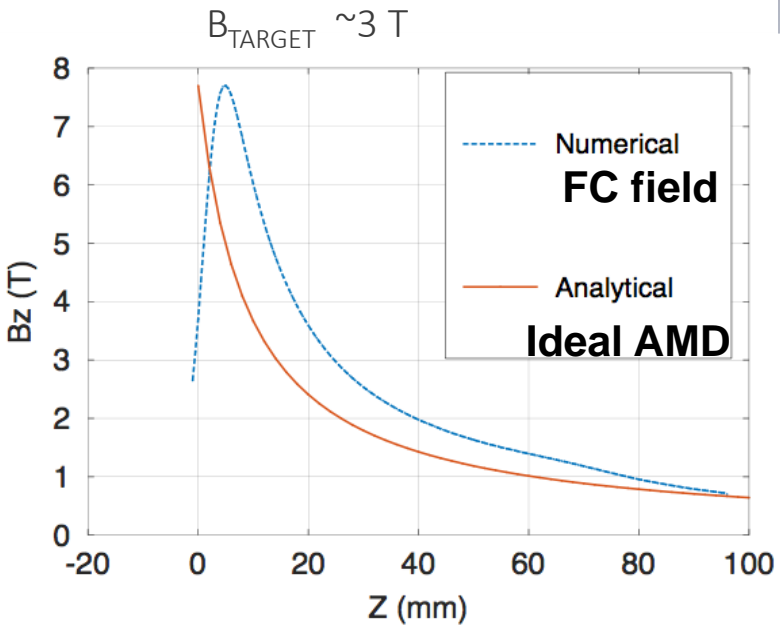
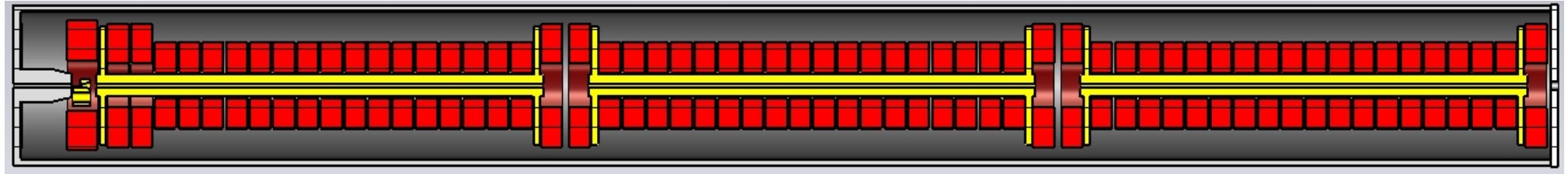

Peak of the magnetic field is at 5 mm from the target => ~40 % drop in capture efficiency



SC Solenoid as the AMD for the FCC-ee

Advantages => higher field value on the target, DC operation
Promising results of the first tests at KEK (next slide)

HTS solenoid

Courtesy of J. Kosse and B. Auchmann (PSI)

$$B(z) = B_W + \frac{B_t - B_w}{(1 + (z/R_s)^2)^{1.5}}$$

- $B_w = 0.8 \text{ T}$
- $B_t = 8.8 \text{ T}$

Design studies started @PSI

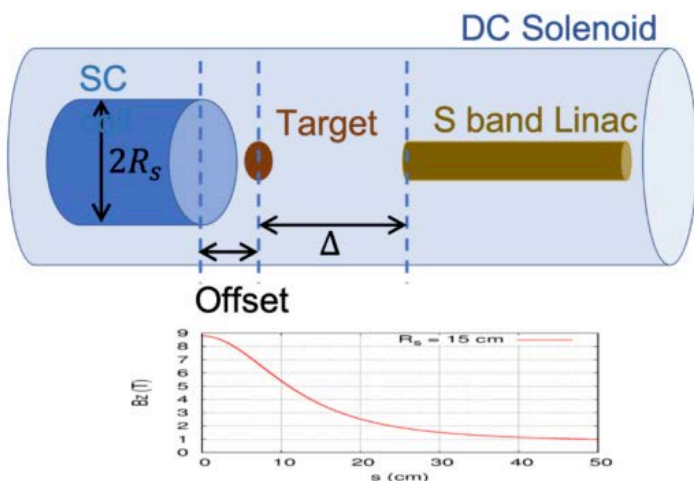
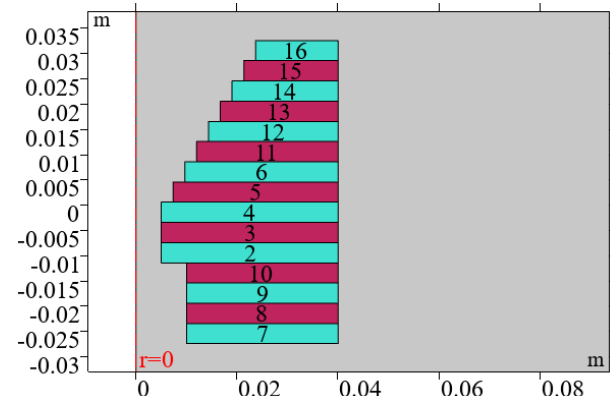
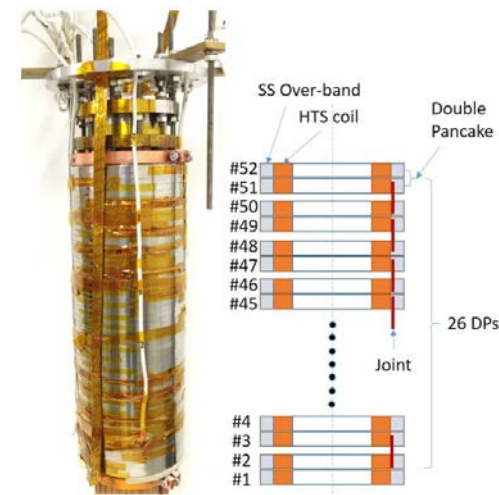
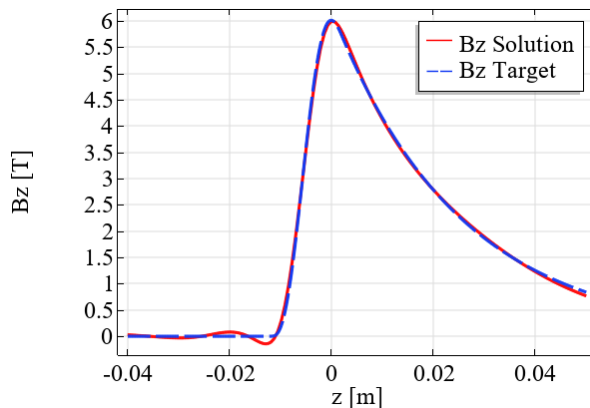
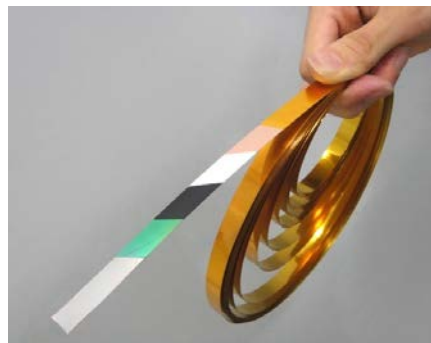

Figure 3: The sketch of the simulation environment.





SC solenoid as the AMD: SuperKEKB Positron Source Design Studies

Courtesy of T. Kamitani (KEK)

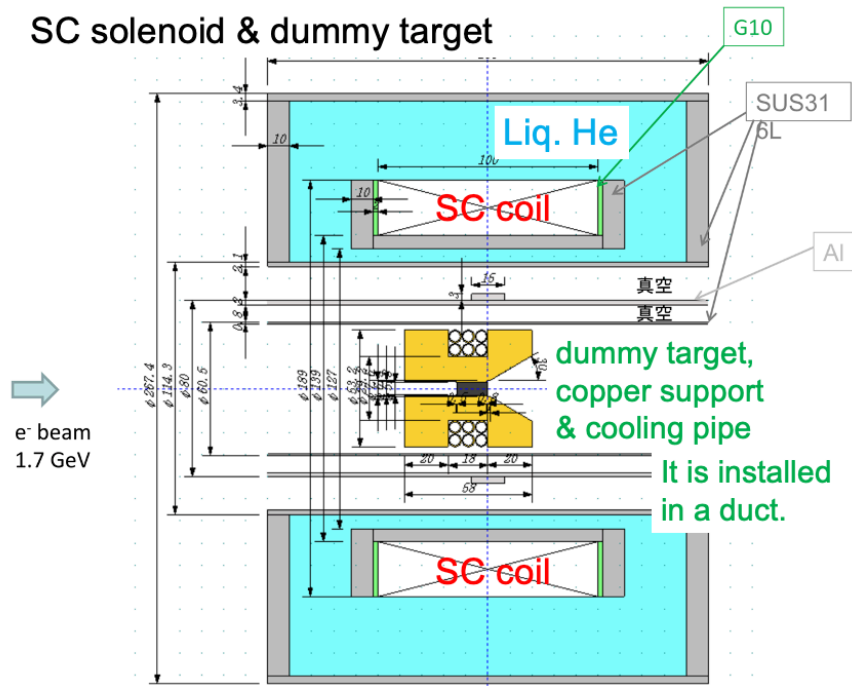

Beam tests in the KEKB linac (2009 - 2011):

- beam irradiation experiment directly into a superconducting solenoid to investigate a quench limit
- beam irradiation experiment of a dummy target installed inside a beam pipe which penetrates a cryostat of a SC solenoid at the beam dump at 1.7 GeV. The solenoid survived at least for 10 minutes at 3.2 T field level with an irradiation of $7nC \times 2$ bunch 1.7 GeV beam at 49 Hz. Max field obtained 4.7 T



Studies on the Positron Production (work in progress)

Electron beam energy 4.46 GeV (FCC-ee Injector CDR baseline)

Beam Parameter	CLIC-like Hybrid	Absorber Hybrid	Conventional	18.5 GeV	SuperCon.
Target thickness	0.4 X_0 / 3.4 X_0	0.4 X_0 / 3.4 X_0	4.5 X_0	6.3 X_0	4.5 X_0
e+ yield @ Target	6.5 e+/e-	6.5 e+/e-	10.5 e+/e-	38.6 e+/e-	10.5 e+/e-
PEDD (Target)	2.1 J/g	2 J/g	24 J/g	80 J/g	24 J/g
Power deposited (Target)	1.5 kW	1.5 kW	2.6 kW	13.2 kW	2.6 kW
AMD Field	7 T	7 T	7 T	7 T	8 T
AMD length	7.4 cm	7.4 cm	7.4 cm	7.4 cm	-
AMD aperture \varnothing	8/44 mm	8/44 mm	8/44 mm	8/44 mm	-
e+ yield @ AMD	2.4 e+/e-	~2.4 e+/e-	5.6 e+/e-	21 e+/e-	10.2
DC Solenoid Field	0.7 T	0.7 T	0.7 T	0.7 T	0.8 T
RF frequency	2 GHz	2 GHz	2 GHz	2 GHz	2.856 GHz
AS length (TW)	1.5 m	1.6 m	1.6 m	1.6 m	3.2 m
Axial E-field	16 MV/m	16 MV/m	16 MV/m	16 MV/m	20 MV/m
Aperture	40 mm	40 mm	40 mm	40 mm	30 mm
e+ yield @ 200 MeV	1.30 e+/e-	1.4 e+/e-	3 e+/e-	11.5 e+/e-	4.6 e+/e-
Accepted e+ yield @ 200 MeV	0.74 e+/e-	0.67 e+/e-	1.4 e+/e-	8.2 e+/e-	1.8 e+/e-

FC

SC-solenoid



FCC-ee Positron Injector (CDR): Bypass for Positron Production

Courtesy of B.Bai (IJCLab/IHEP)

Arc scheme

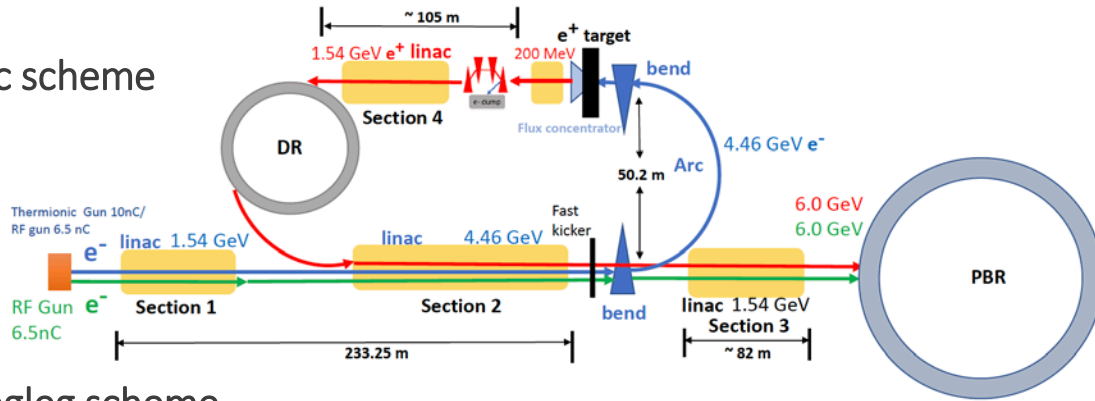

Dogleg scheme

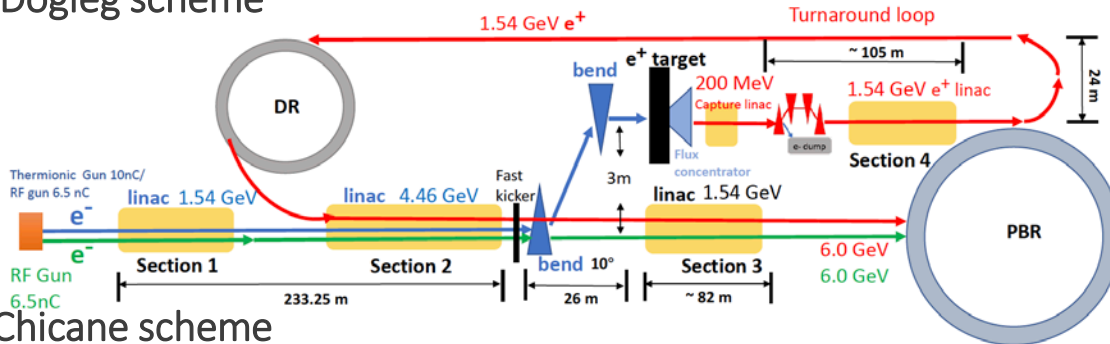

Chicane scheme

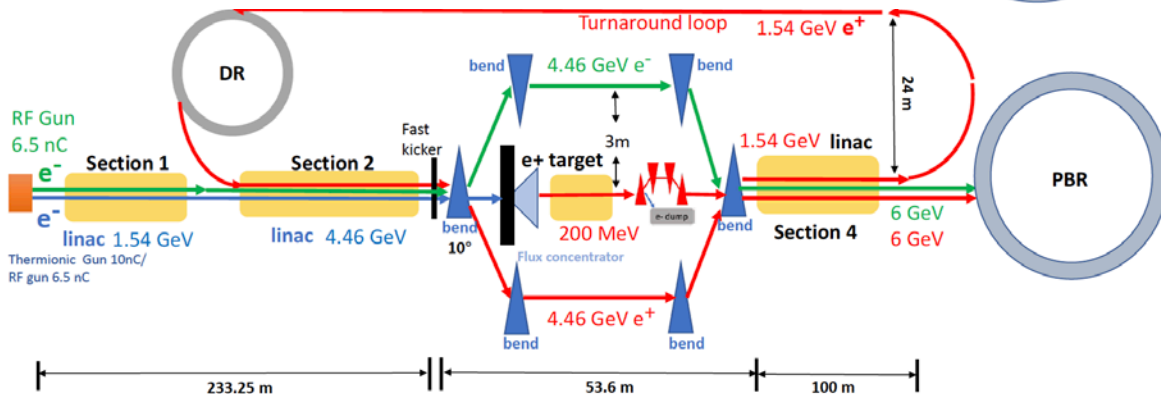

- CDR: FCC-ee Injector complex is based on the SuperKEKB scheme with fixed target (has a hole for e- beam passage)
- Positrons from the target share the same linac with electrons
- Additional degradation of the positron yield
- 3 bypass schemes are proposed to achieve a better performance and increase flexibility
- All can meet the requirement of the Z running of the FCC-ee (e+ yield is $\sim 1.2 e^+/e^-$)

1. Dogleg scheme

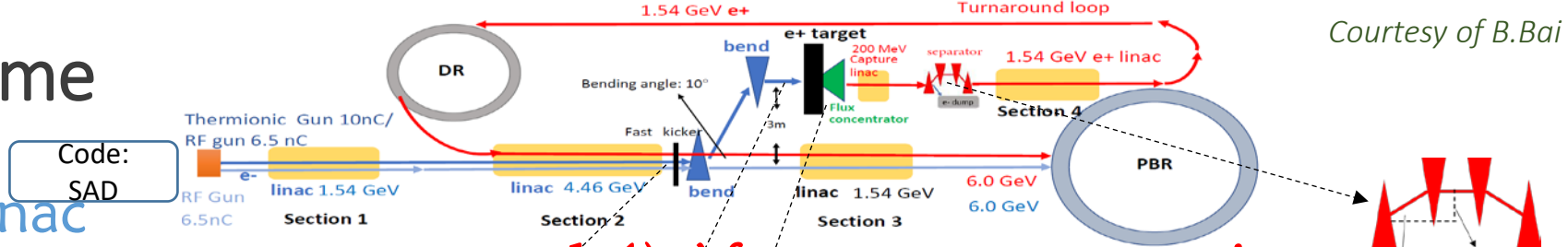

Code: SAD

1.1) 4.46 GeV e- linac

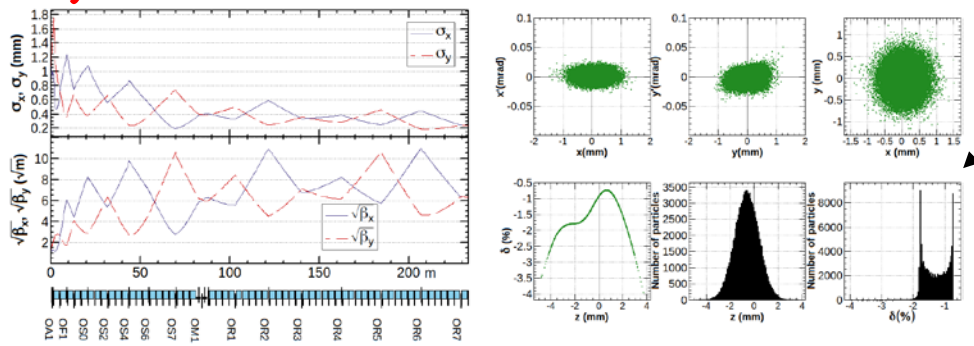

1.4) After e+ capture section: separator, chicane, 1.54 GeV e+ linac, turnaround loop

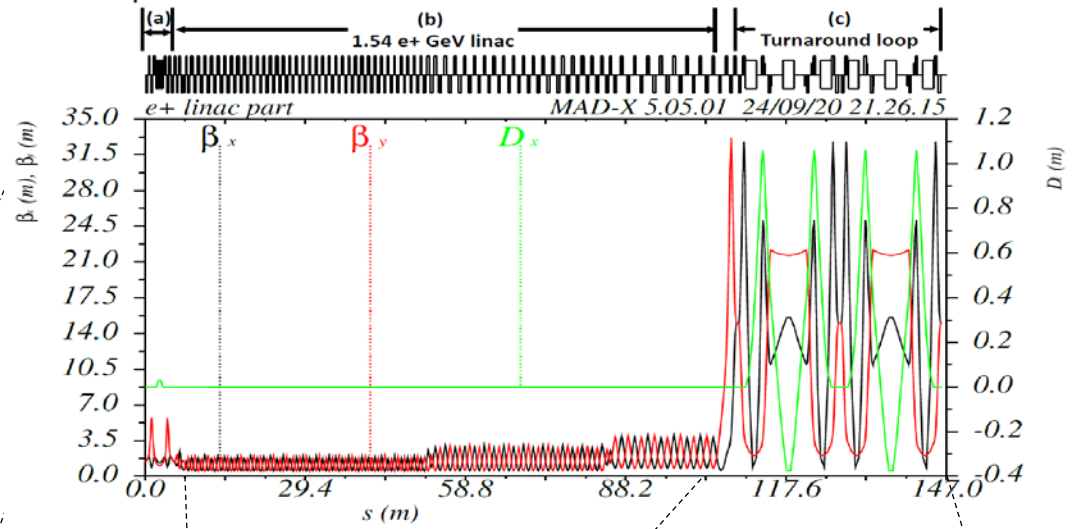

1.2) dogleg bypass

Code: MADX + PLACET

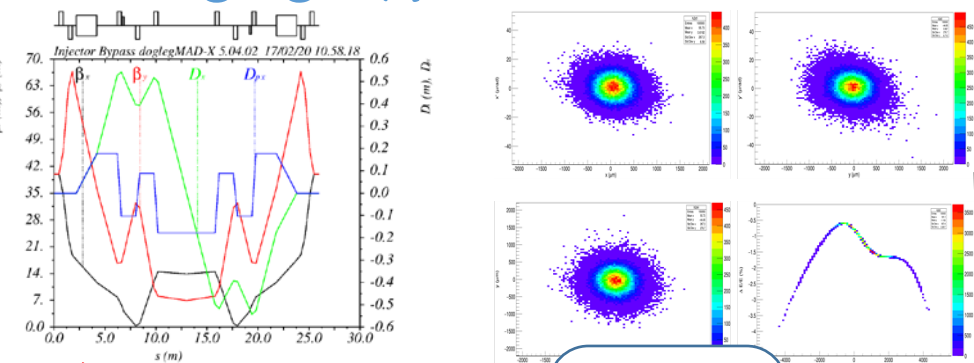

1.3) e+ generation

Results from Dr. Yanliang Han

Accelerating mode /decelerating mode + Conventional target /hybrid target

Conventional target + decelerating mode
Positron yield: 2.3

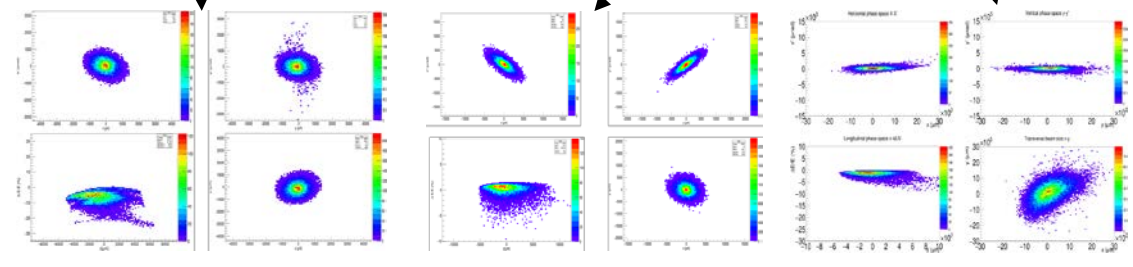
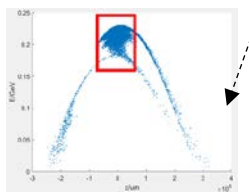



FCC-ee Injector Update Studies and Proof of Principle Experiment

- Recently the *Swiss Accelerator Research and Technology (CHART II)* collaboration approved to finance the FCC-ee Injector update studies and a proof of principle for a positron source at PSI/SwissFEL facility
 - Collaboration between PSI and CERN with several external partners (IJCLab, INFN-LNF, INFN-Ferrara, BINP, KEK...)
 - Duration 4 years (from September 2020) + to be considered 1 year extension
 - FCC-ee injector studies: 7 WP (Coordination, e+/e- 6 GeV injector linacs, e-/e+ linac extension study, Positron Source: target and capture system, DR and TL, CDR+, Proof of principle capture in SwissFEL)
 - Goals:
 - review of the actual CDR/Injector and write a CDR+/Injector with cost estimate
 - Proof of principle of the positron source at PSI/SwissFEL



New Layout of the FCC-ee Injector 6 GeV (20 GeV)

Outcome from WP0.2 meetings leading by A. Grudiev

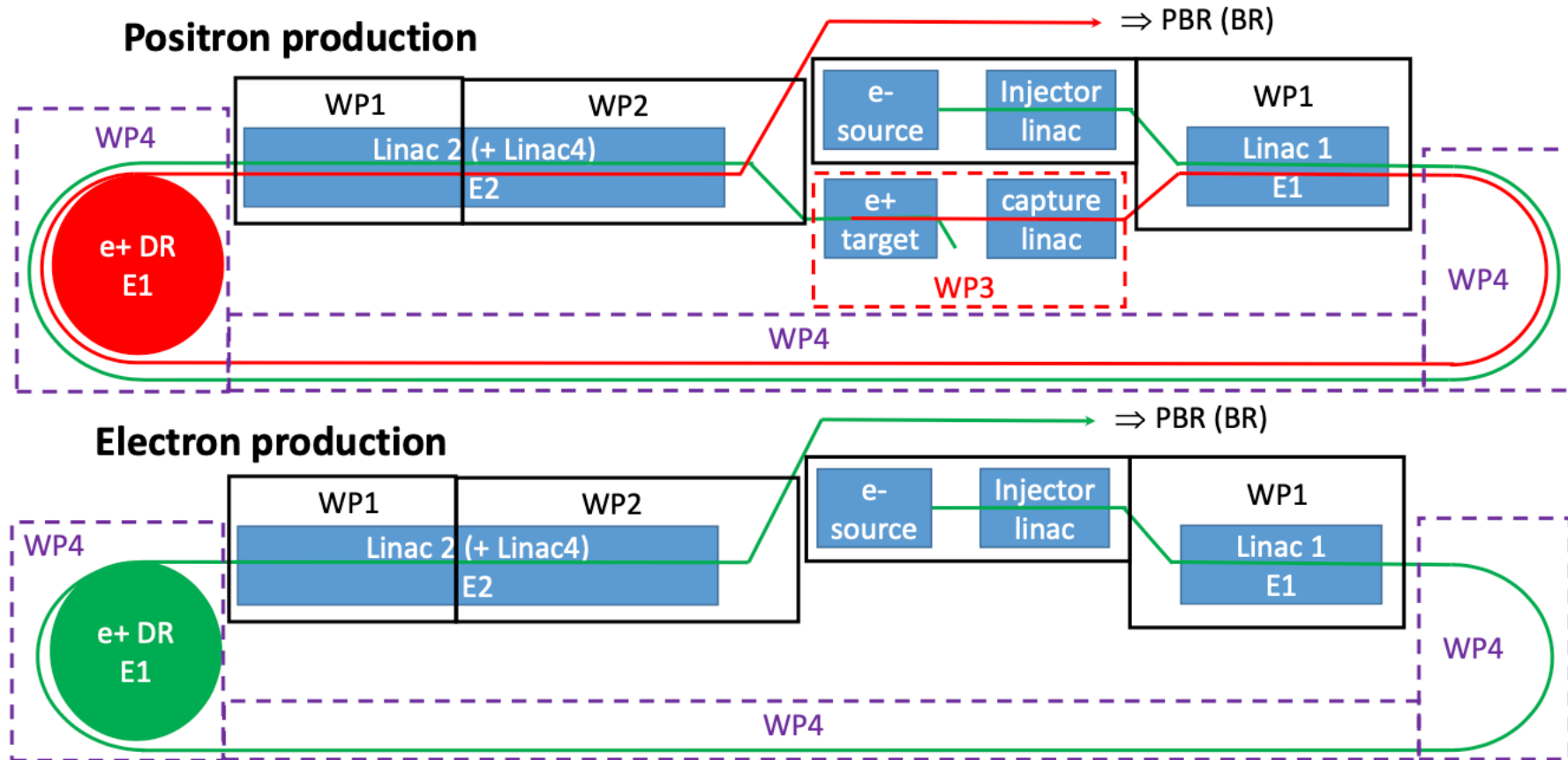

A full injector energy (6 or 20 GeV) can be used for the positron production



FCC-ee injector: Overall Parameter Optimization (work in progress)

Outcome from WP3

Simulations with the conventional scheme + FC + S-band acc. structures

	DR acceptance 3.8%		DR acceptance 7.8%		
	6	20	6	20	
Beam energy					GeV
e+ bunch charge @200 MeV	4,20E+10	4,20E+10	4,20E+10	4,20E+10	e+
Bunch charge	3,26E+10	1,11E+10	2,82E+10	9,23E+09	e-
Bunch length (rms)	1	1	1	1	mm
Bunch transv. size (rms)	1,8	1,9	1,9	1,9	mm
Bunch separation	wakefiled limit	wakefiled limit	wakefiled limit	wakefiled limit	ns
Nb of bunches per pulse (max)	25	25	30	30	
Repetition rate (max)	100	100	100	100	Hz
Beam power	78,24	88,8	81,216	88,608	kW
Beam energy	782,4	888	812,16	886,08	J
Emittance (normalised max)	< 1	< 1	< 1	< 1	mm.rad
Energy spread	< 1	< 1	< 1	< 1	%
PEDD (target)	32.8	31	31.2	31	J/g
Deposited power (target)	14.6	16.8	15.2	16.8	[kW/pulse]

e- drive beam

Drive beam energy	6 GeV			20 GeV			
	FULL	±3.8% @2MV	±7.8% @4MV	FULL	±3.8% @2MV	±7.8% @4MV	
Total e+ yield	2,64	—	—	8,1	—	—	Ne+/Ne-
Accepted e+ yield	—	1.46 ($\sigma_{x/y} = 1.5\text{mm}$)	1.94 ($\sigma_{x/y} = 1.2\text{mm}$)	—	4.46 ($\sigma_{x/y} = 1.5\text{mm}$)	5.93 ($\sigma_{x/y} = 1.2\text{mm}$)	Ne+/Ne-
Bunch length (rms)	—	2,2	2,7	—	2,2	2,7	mm
Emittance geometrical (rms)	23,7	17,2	18	—	—	—	μm
Energy spread (rms)	—	6,0	8,3	—	6,0	8,3	%

e+ beam
@200 MeV



Introduction to the PSI/ SwissFEL

Courtesy of P. Craievich (PSI)

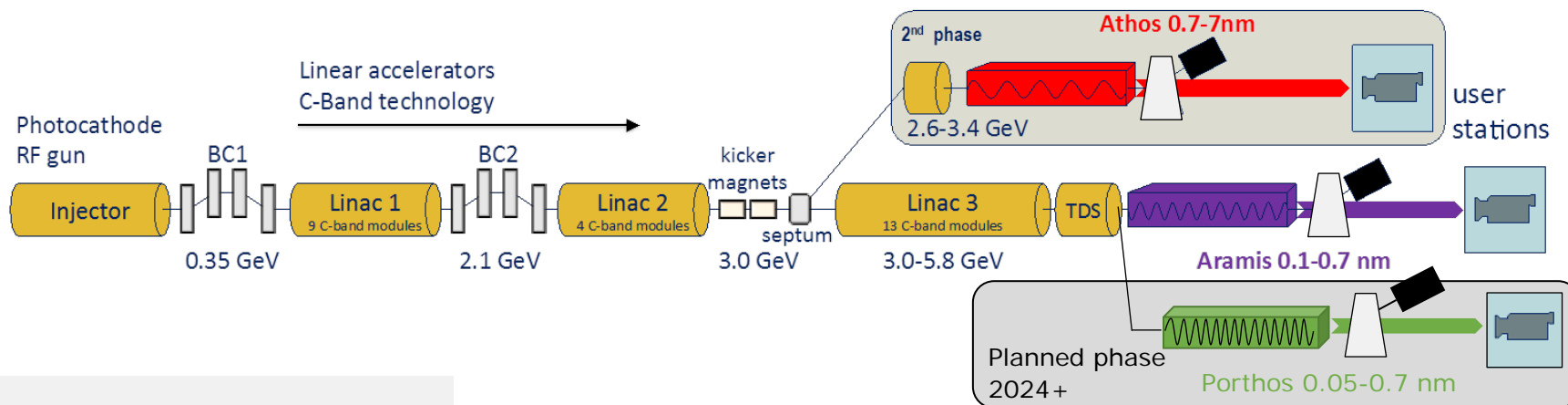

Main parameters

Beam energy	6.2 GeV
Bunch charge	10-200 pC
Repetition rate	up to 100 Hz
Pulse duration	<1 fs – 3 ps (rms)
Norm. emittance	400 nm
Overall length	740 m





Positron source in PSI/ SwissFEL: Proof of Principle Experiment (WP6)

SwissFEL transfer lines

Courtesy of P. Craievich (PSI)

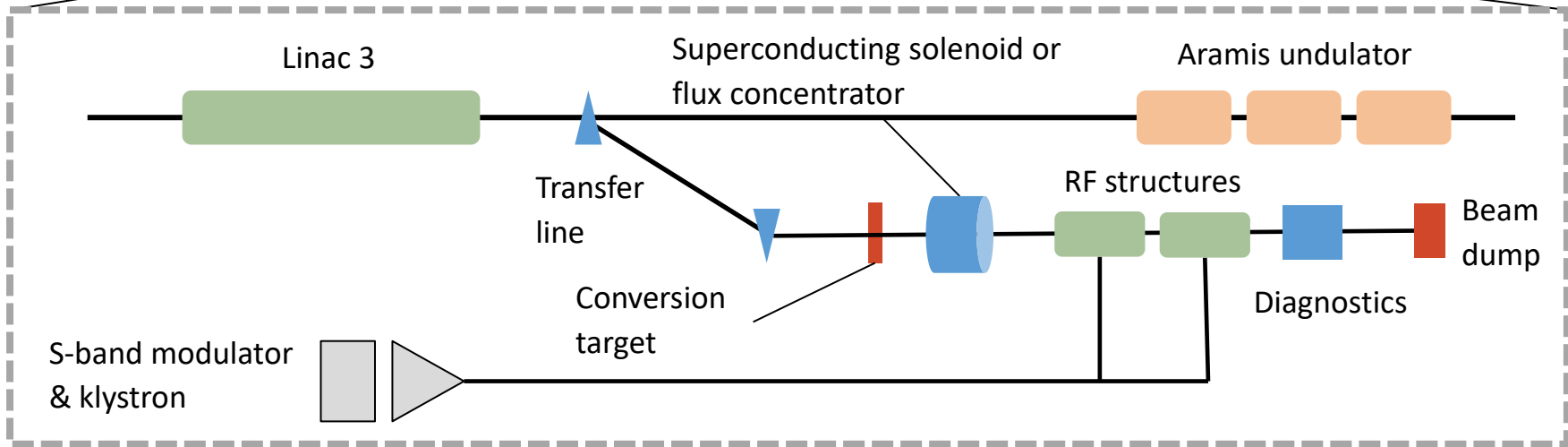
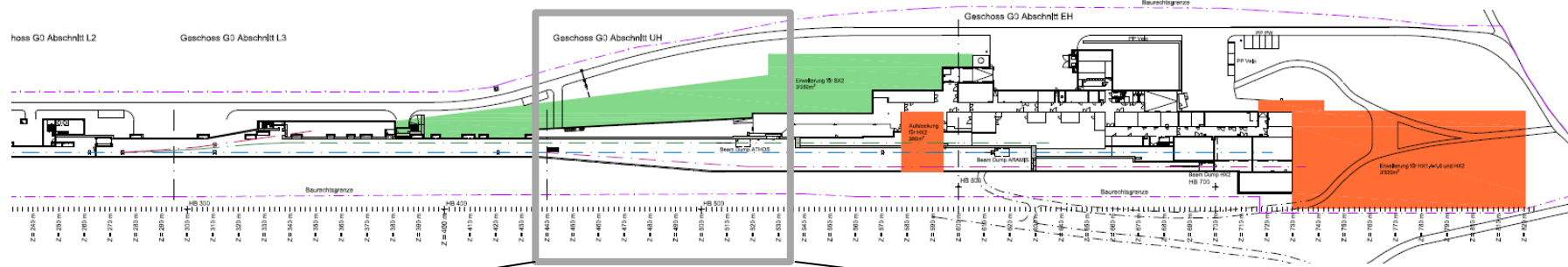

Thank you for the attention!