

SuperKEKB status

-Startup after Long Shutdown 1-

Makoto Tobiyama

KEK Accelerator Laboratory



Major upgrade items of LS1(Jun 2022-Jan 2024)



- Replacement of damaged collimator heads on both rings.
- QCSR cryostat vacuum leak
- Aperture enlargement of injection channel and modification of injection final septum of HER.
- IR radiation shield modifications.
- Non-linear collimator at OHO straight section of LER.
- Installment of beam loss monitors/ acoustic sensors/ bunch oscillation monitors to monitor sudden beam loss event.
- DR kicker power supply maintenance.

Vacuum works during LS1 at a glance (MR)



— : Area open to dry nitrogen or atmosphere

LER

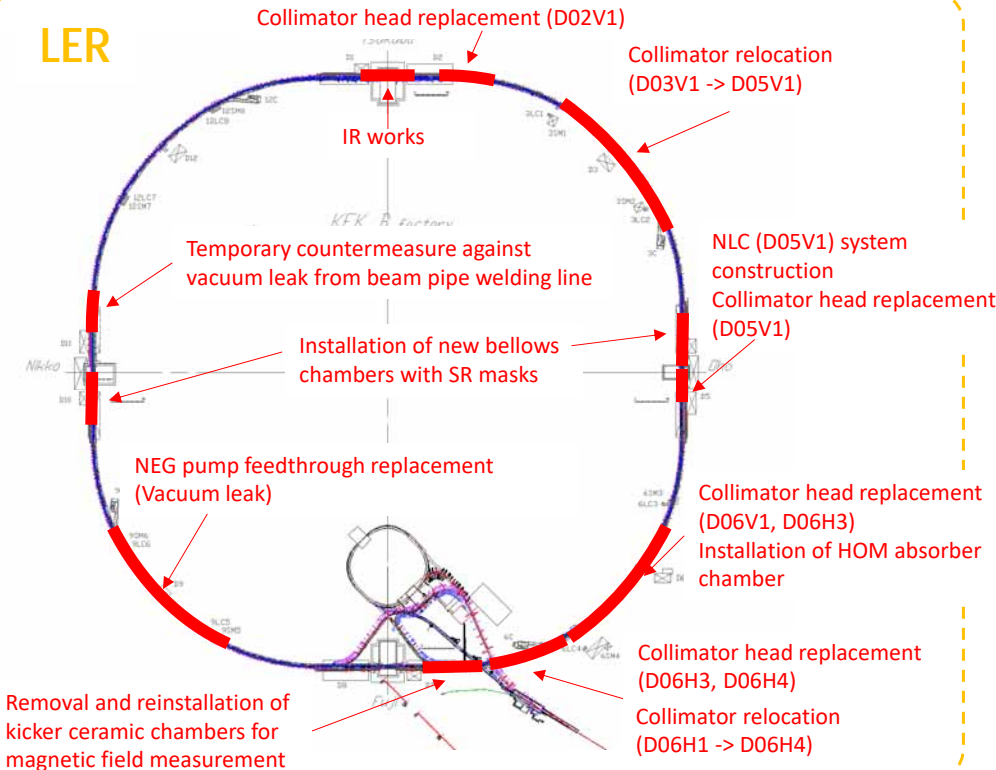

HER

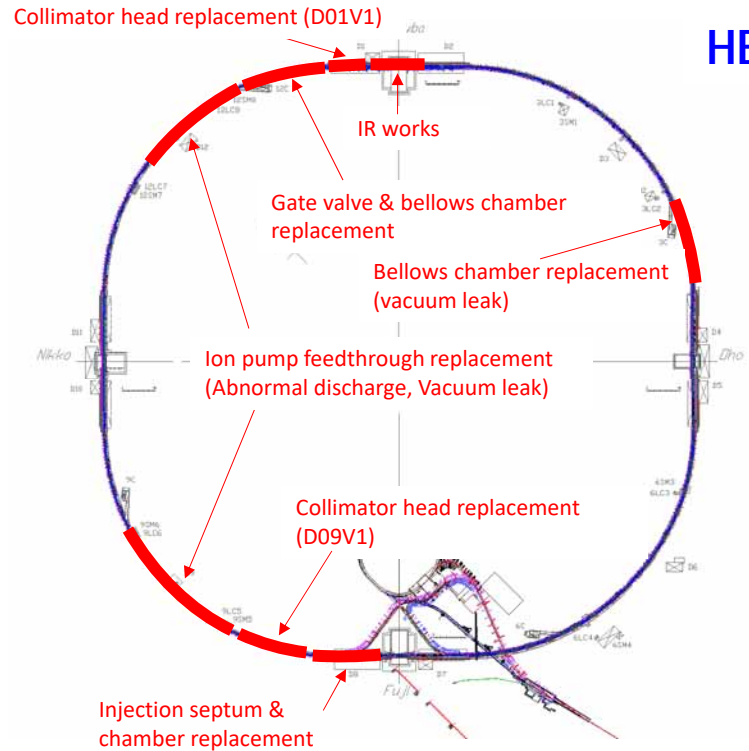

Vacuum works during LS1 at a glance (BT&DR)

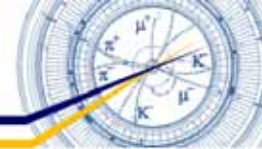

— : Area open to dry nitrogen or atmosphere

BT

Installation of V-offset bellows chambers (BTp)
Installation of CSR monitor chamber (BTp)

Installation of OTR screen monitor (BTp)

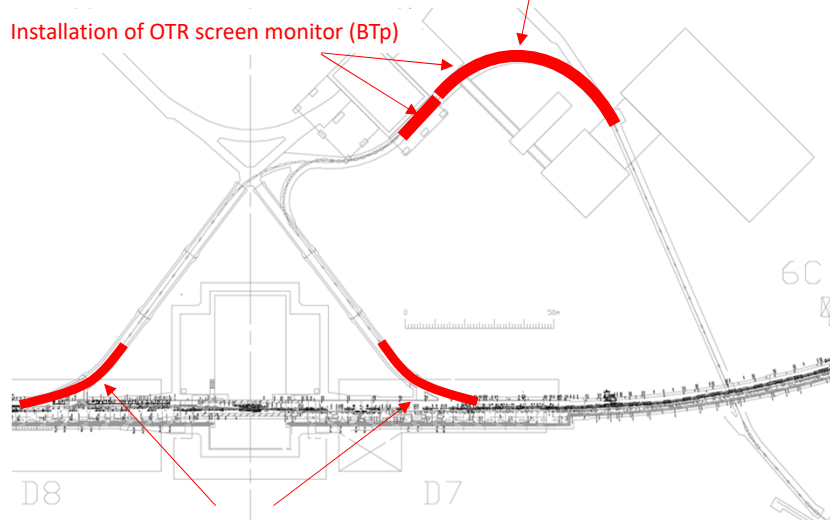

Removal and reinstallation of bellows chambers for magnet alignment (BTe & BTp)

DR

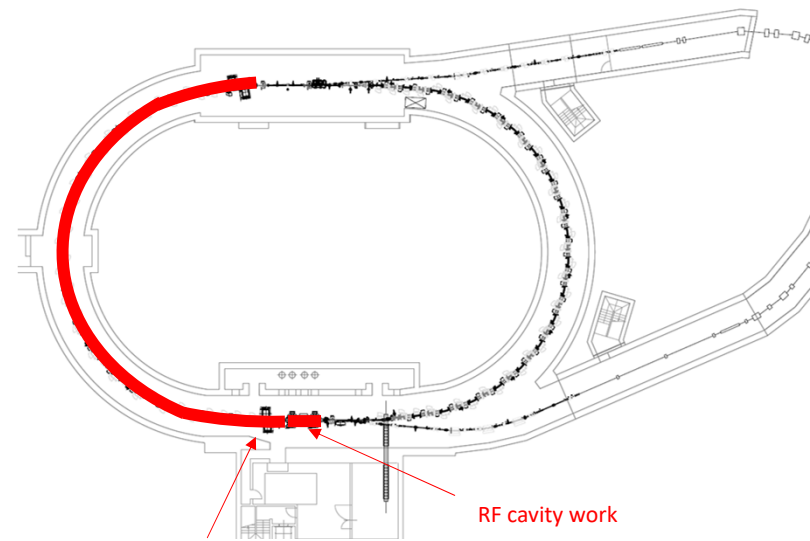

Removal and reinstallation of Ext. kicker chambers for Kicker PS work

RF cavity work



QCSR
真空漏れ
改修
(1/5)

T. Oki



IR radiation shield modification

Implementation on Geant4 Geometry

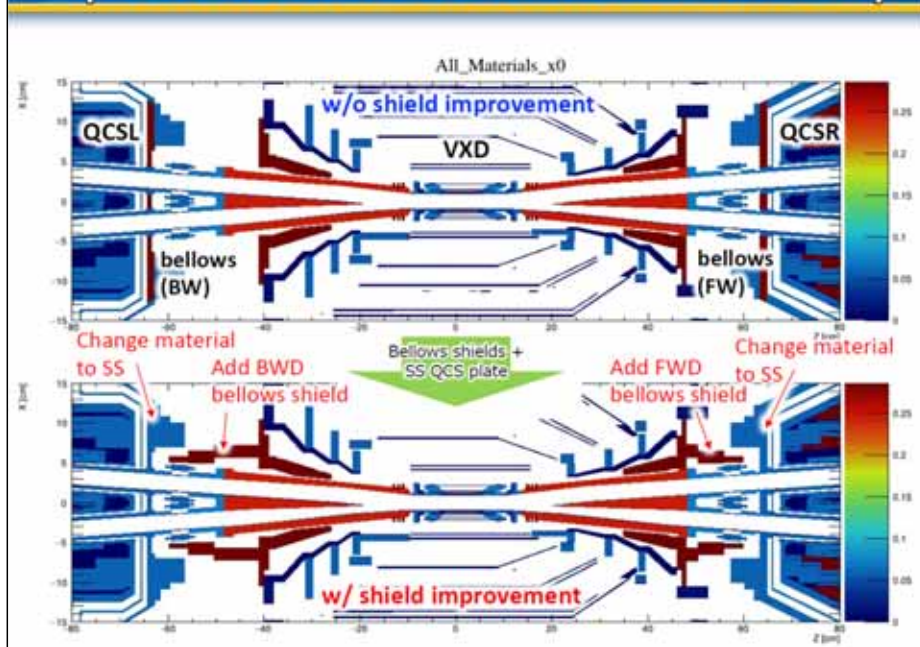

• Additional shields reduce the beam BG of CDC and TOP well.

- CDC: 13%~30% for single beam BG, 30~50% for luminosity BG
- TOP: about 20% for both single beam BG and luminosity BG

• No bad signature on the beam BG of PXD and SVD.

K. Nakamura (2022.02.04)
10th SuperKEKB long-term
operation plan meeting

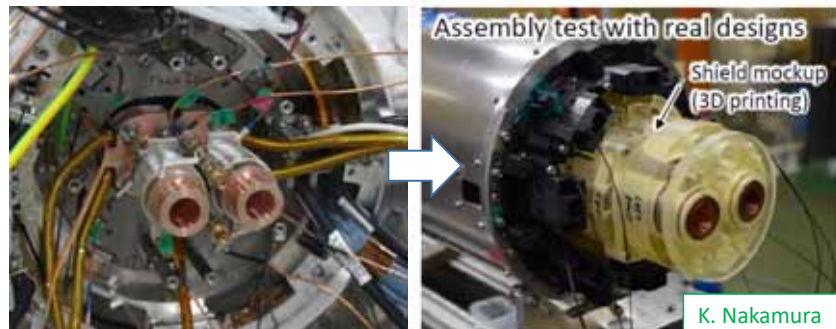

New heavy metal shield on IP bellows

K. Nakamura

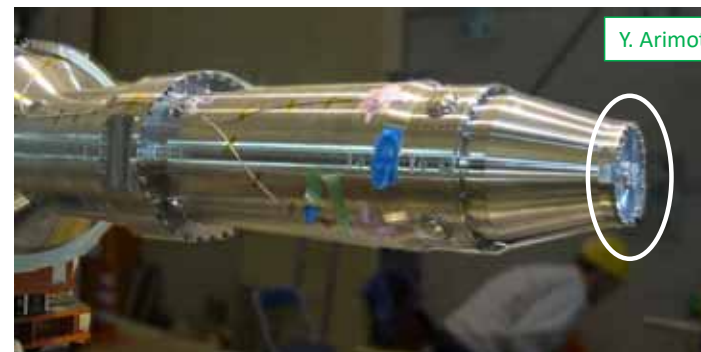

Y. Arimoto

Material change from W to SUS (QCS cryostat front plate)
(Tip of QCS cryostat will be modified to make more space)

IR radiation shield modification

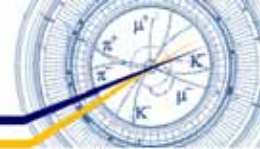

- Additional concrete shield (IR) & polyethylene shield (Belle2)

- For shielding fast neutrons

- New concrete shields and polyethylene (PE) shield will be added to a space that currently has no shield.
- Additional PE shields around QCS are also planned.

- Expected effects of shield modification

- Physics run with wider collimator setting
- Physics run with larger total currents and bunch current

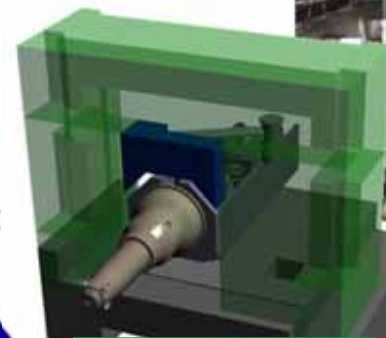
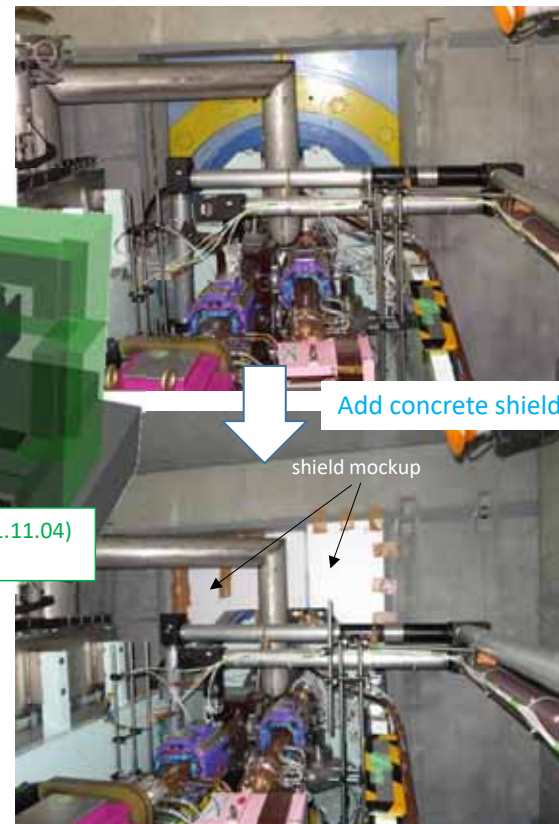

H. Yamaoka (2021.11.04)
IR meeting

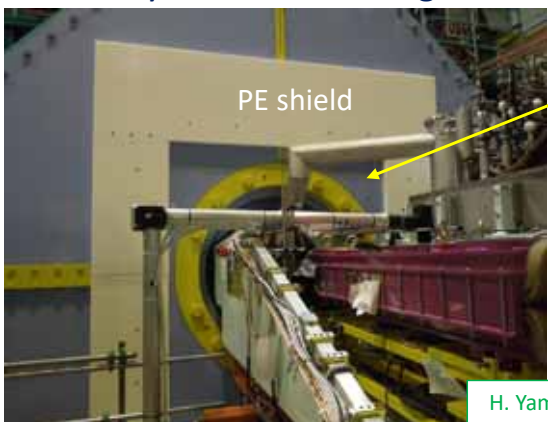

Add PE shields

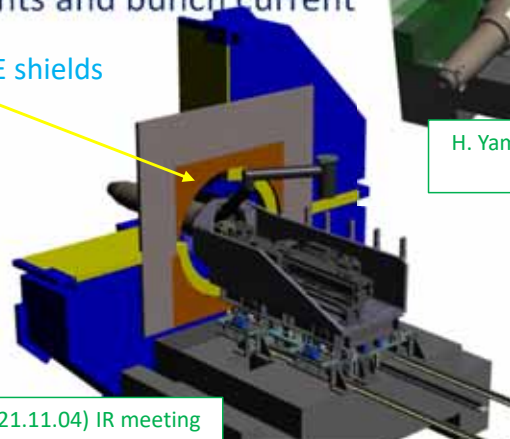

H. Yamaoka (2021.11.04) IR meeting

NLC construction

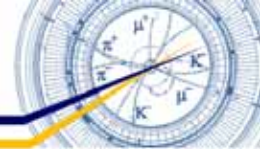

- Non-linear collimator (NLC) is being installed in LER Oho straight section.

- Impedance of NLC is much lower than that of conventional collimator due to its large aperture.
- NLC can relax TMCI bunch current limit.
- Oho straight section is the location where the optics satisfies the requirements for NLC.
- A part of wiggler magnets need to be removed.
- New skew sextupole magnets and beam pipes in them need to be fabricated.
- New power supplies, cabling works and new radiation shields are also required.

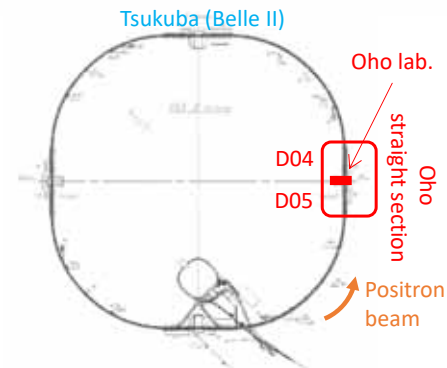
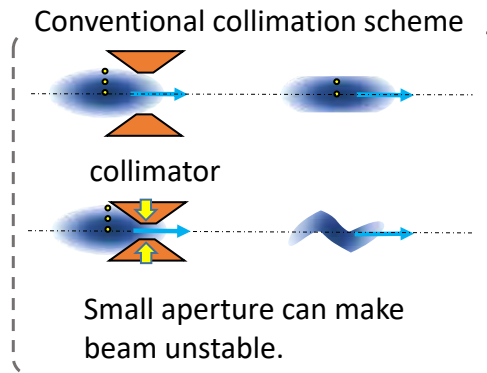

Non-linear collimation scheme (conceptual diagram)

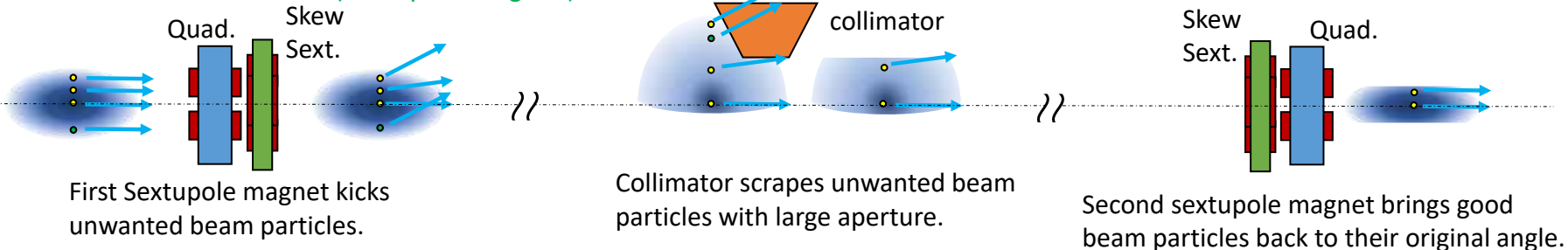

2021c physics run

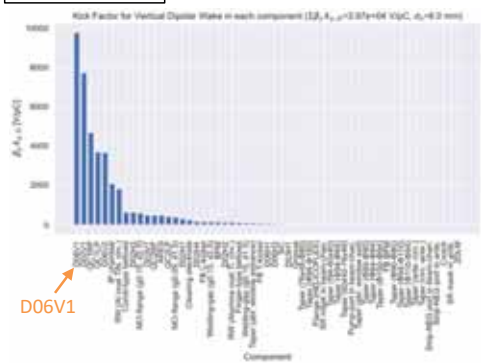

LS1後

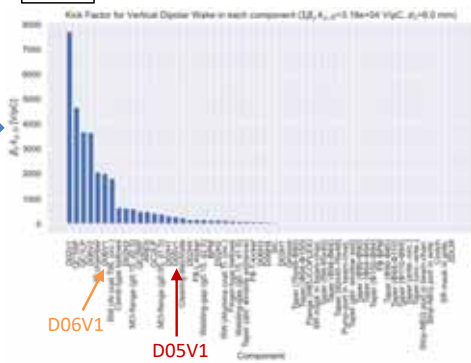

$\beta_y^* = 1 \text{ mm}$
 $\beta_x^* = 80 \text{ mm}$

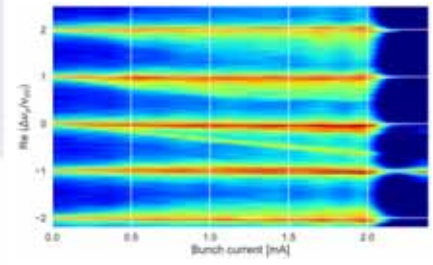

- $\Sigma\beta_y k_y$ will reduce from $3.97e4$ down to $3.18e4 \text{ V/pC}$
- Threshold of TMCI is estimated to increase more than $2. \text{mA/bunch}$

Photo of the non-linear collimator section (2023-05-26)

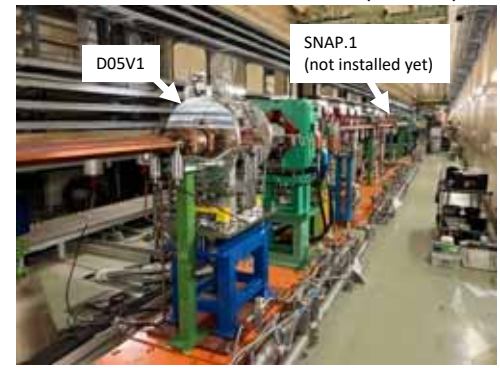

Nonlinear Collimator



Nonlinear Collimator

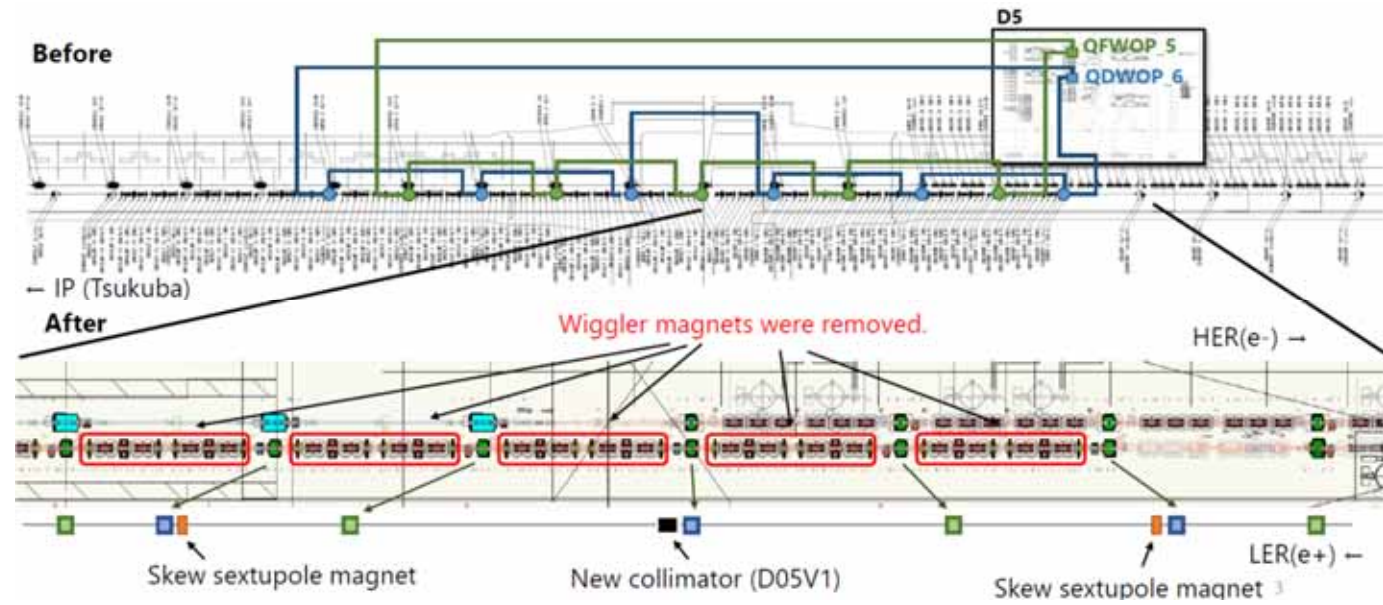

Other Collimators

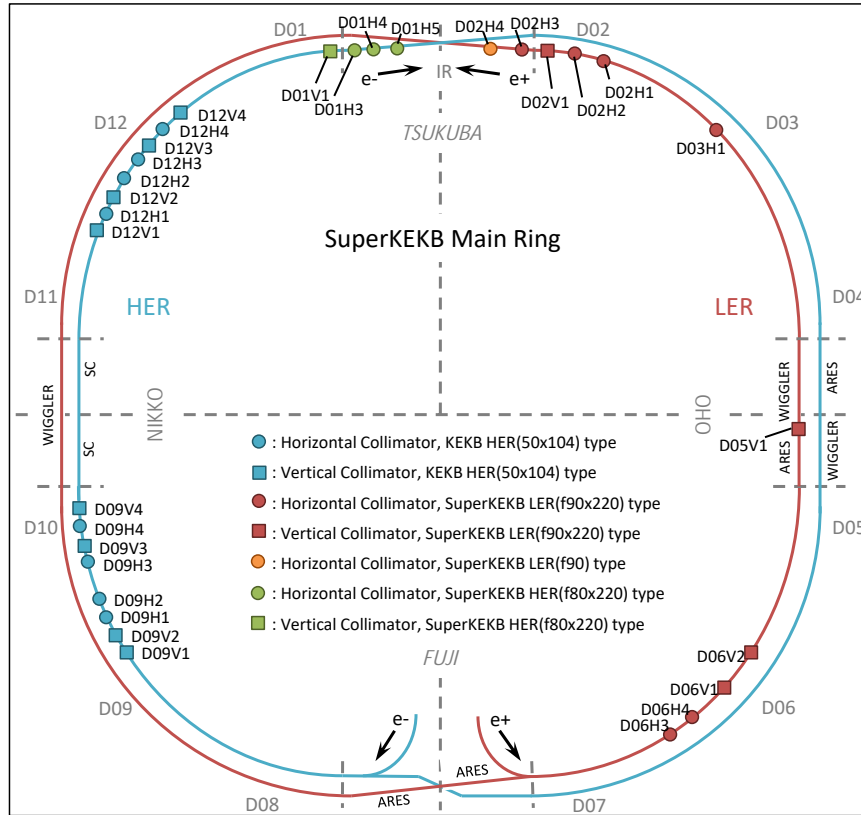

Other major works (excluding Linac)

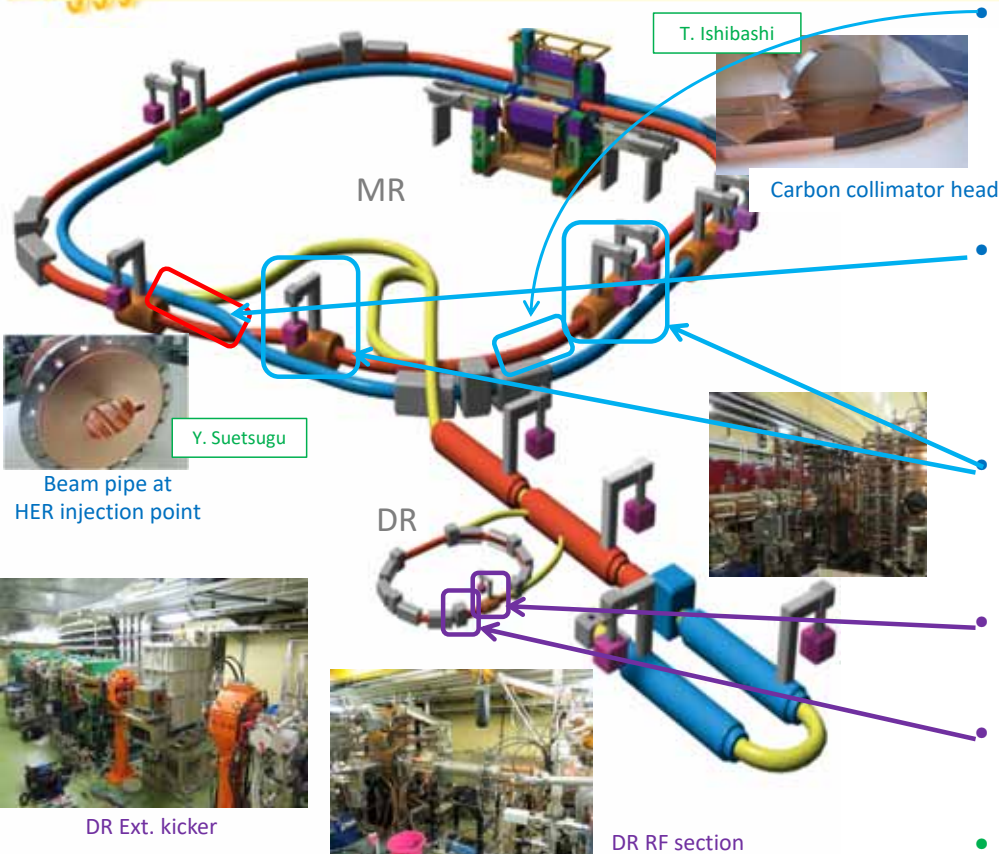
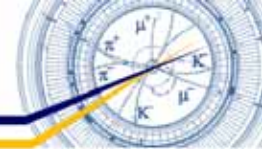

Robust collimator head (LER)

- As countermeasure against kicker-pulsar misfiring and resulting destruction of collimator
 - Replacement with carbon head of horizontal collimator D06H3 and relocation from D06H1 to D06H4
 - Carbon head production : ~ March 2023
 - Head replacement : Spring ~ Summer 2023
 - Collimator relocation : Spring ~ Summer 2023

New beam pipes with wider aperture at HER injection point

- For injection efficiency improvement
 - New beam pipes with wider aperture & New BPM for precise measurement of injected beam
 - Beam pipe production : ~ March 2023
 - Beam pipe replacement : Spring ~ Summer 2023
 - Septum baking : ~ Summer 2023?

RF cavity modification and replacement (LER)

- For stable operation with larger beam current
 - Modification : Input coupler replacement, cooling power enhancement, coaxial line modification, etc. (done)
 - Cavity replacement (D05A) : January ~ February 2023

Vacuum seal replacement at RF section (DR)

- For pressure reduction
 - Replacement from elastomer gasket to metal gasket for dummy pipes (done)

DR Extraction kicker power supply modification and repair (DR)

- For stable operation
 - Modification : December 2022 ~ August 2023

• And so on...



Beam pipe at HER injection point



DR Ext. kicker



DR RF section



Carbon collimator head



T. Ishibashi



Y. Suetsugu



- Replaced 16 old accelerating structures with new ones (with larger energy gain).
 - Starting fabrication of 12 additional accelerating structures
- New fast kickers (kick first and second bunch independently), larger aperture pulsed-Qs have been installed.
 - Successful beam tuning using machine-learning method (Bayesian optimization)
- Study of BT beam blowup
 - Rejected the CSR-induced beam blowup in positron line
 - Still hunting the cause of blowups.
- Next step
 - Beam diagnostic line at SY3
 - BTe-ECS(2024-2025)
 - Beam optimization
 - etc..

Beam diagnostic line at SY3

Construction of a line for beam diagnostics amid steady-state injection

- Modification of the beam-dump line on the east side of SY3 to extract a beam at regular intervals for continuous diagnostics and data accumulation without affecting HER beam injection
- Scheduled in Summer 2024 (equipment manufacturing and procurement are in progress)
- Essential system to improve beam-control accuracy and achieve highly stable beam

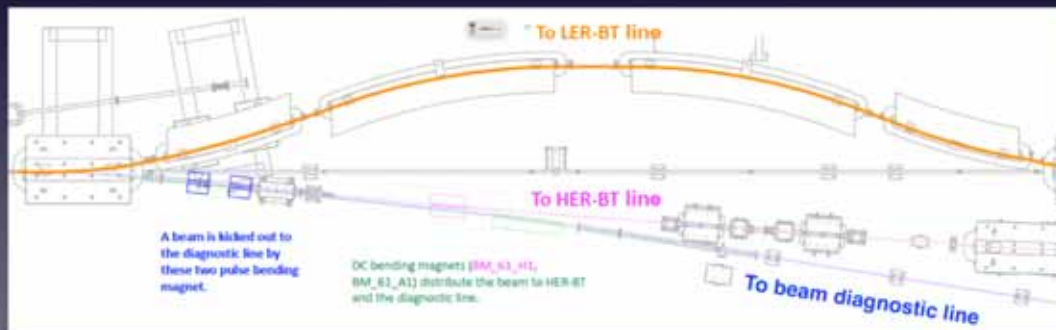

T. Kamitani, T. Okayasu

Beam diagnostic line at SY3

Installation of high-precision beam diagnostic instruments

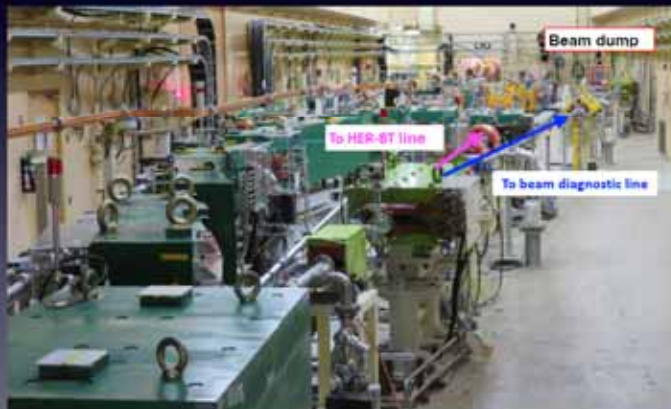

F. Miyahara

Beam position monitor



- Beam orbit measurement
- Optimization and maintenance of beam energy



Beam profile monitor

- Beam energy distribution
- Optimization and maintenance of longitudinal beam structure

BTe-ECS (2024-2025)

Reduction in longitudinal beam emittance of HER by new ECS system

Schematic layout



M. Yoshida

S-band 3m accelerating structure

- Equipment fabrication and procurement in progress
- Installation of RF source completed and application procedures for utilization of the RF system in progress
- High power test and radiation measurement of S-band 3m accelerating structure (transferred from SPring-8) from January 2024

Beam simulation

Injection efficiency

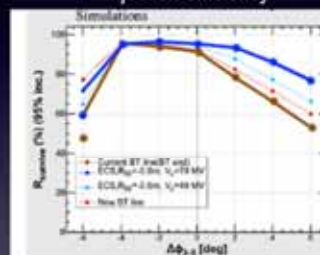

Longitudinal emittance (2Jz)

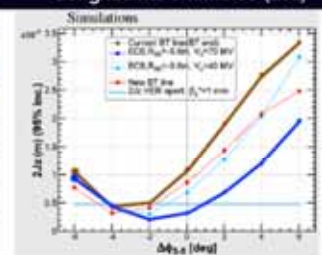

N. Iida, T. Yoshimoto

Simulation results

- Effective reduction in longitudinal emittance lower than HER acceptance at operating condition of $R_{se} = -0.6$ m and $V_c = 70$ MV
- Estimated injection efficiency over 95%

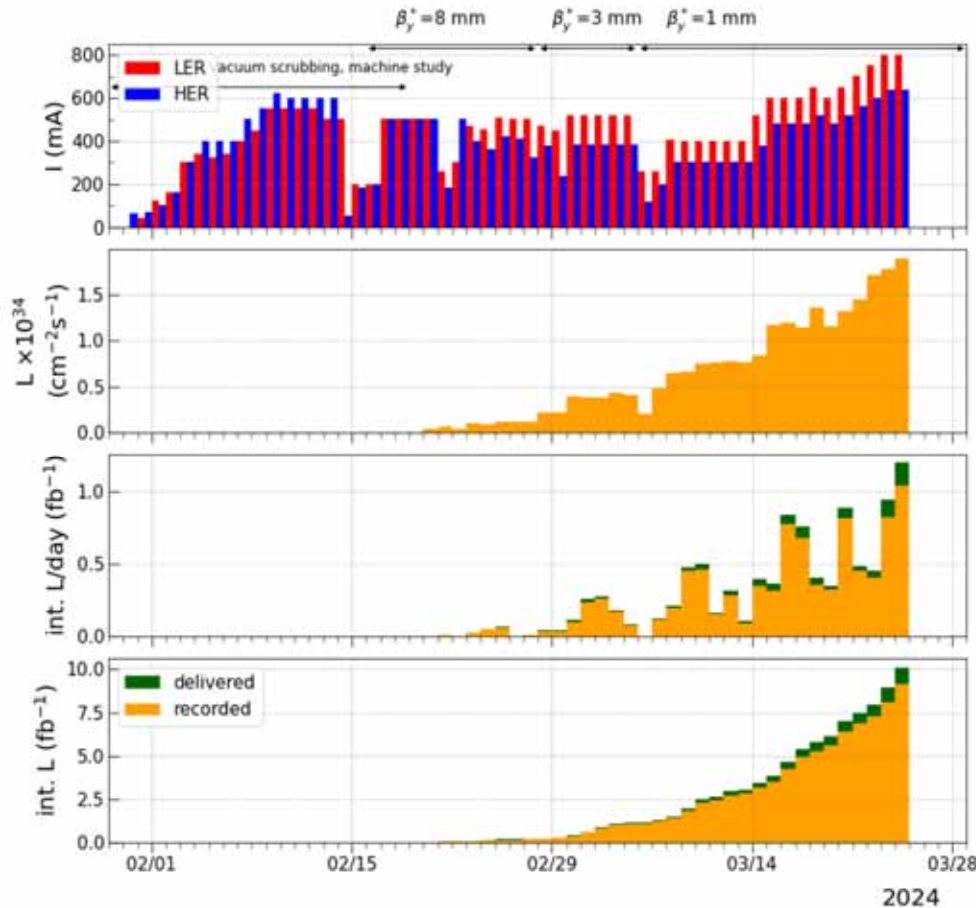

- Vacuum Scrubbing: January 29 - Feb. 20
- $\beta_y^* = 8 \text{ mm}$ Collision: Feb. 20 - Feb. 28
- $\beta_y^* = 3 \text{ mm}$ Collision: Feb. 28 - March 5
- $\beta_y^* = 1 \text{ mm}$ Collision: March 6 -
 - Crab Waist OFF until March 18
 - Crab Waist ON since March 18
 - LER: 80 % and HER 40 %
- Increase Beam Currents with 2346 Bunches
- Machine Troubles
 - LER Injection Kicker Accidental Fire
 - Chiller and Cooling Water Pump Trouble (OHO)
 - LER RF D07B Klystron End Of Life
 - Magnet PS Trouble (SD3ORE and QFROE_4)

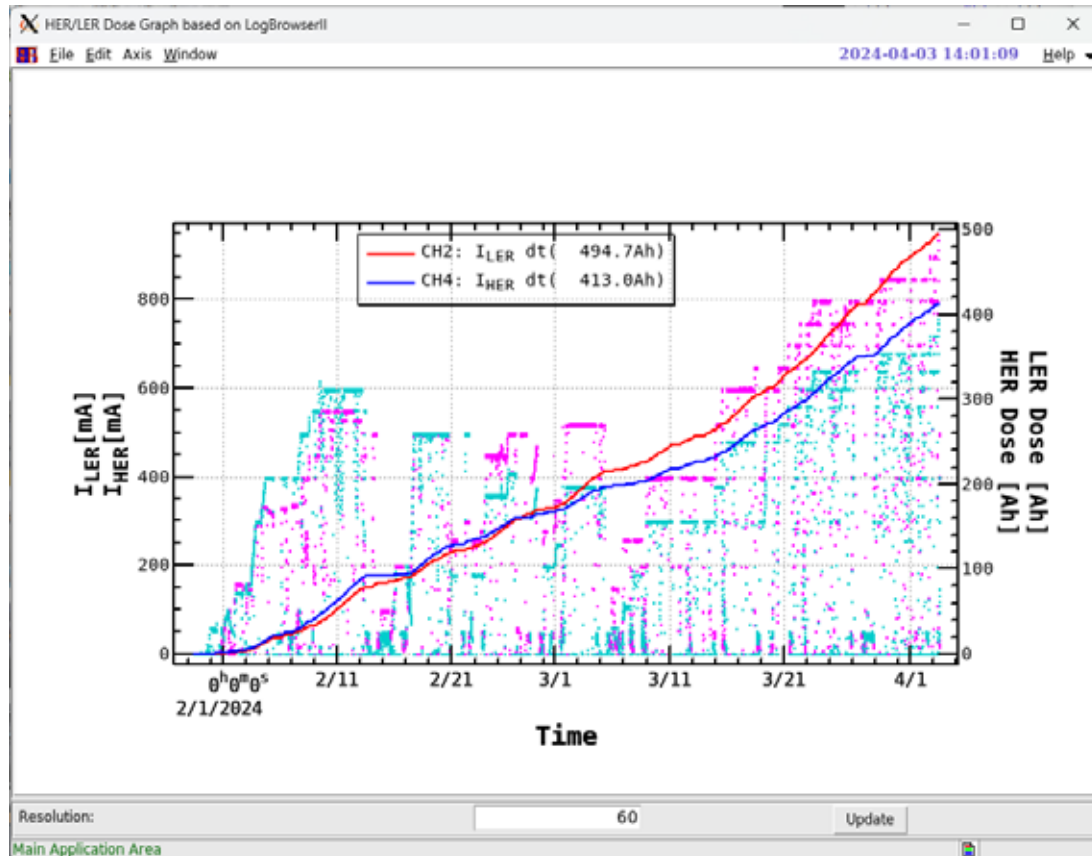

- Physics Run
 - $\beta_y^* = 1 \text{ mm}$
 - CW: 80 % (LER) and 40 % (HER)
 - LER: 800 mA and HER: 640 mA with 2346 Bunches
 - $L = 1.9 \times 10^{34} \text{ cm}^{-2}\text{s}^{-1}$
 - Luminosity Performance Is Back at the Performance of 2022ab Run.
- Single Beam Vertical Emittance
 - $\epsilon_y = 10 \text{ pm} - 20 \text{ pm} \rightarrow 25 \text{ pm} - 35 \text{ pm}$ in 2022b Run
 - Key Point: Beam Orbit at IP and at Strong Sextupoles with BBA
- Injection Efficiency
 - LER: 100 % and HER: 20 % from Scratch
 - HER is Still Poor Efficiency.

$\beta_y^* = 1$ mm: Crab Waist OFF and ON

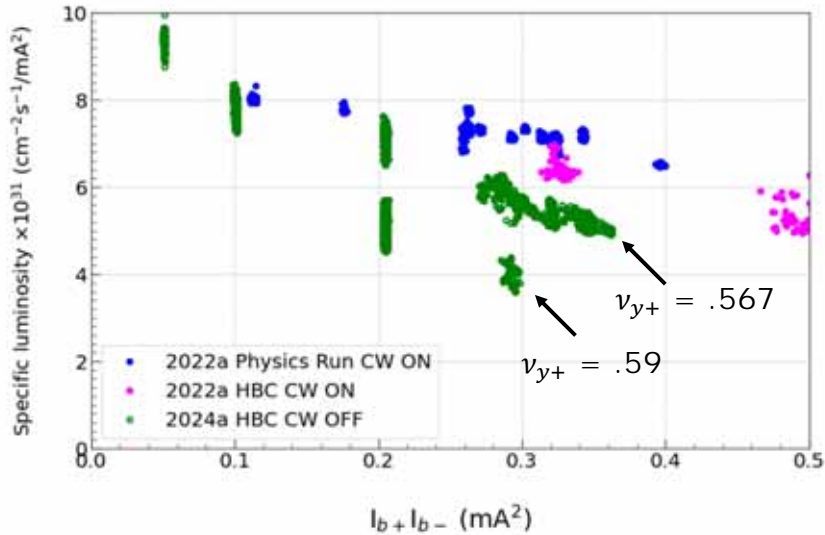

$\beta_y^* = 1$ mm: Crab Waist OFF

March 12, 2024: CW 0 %

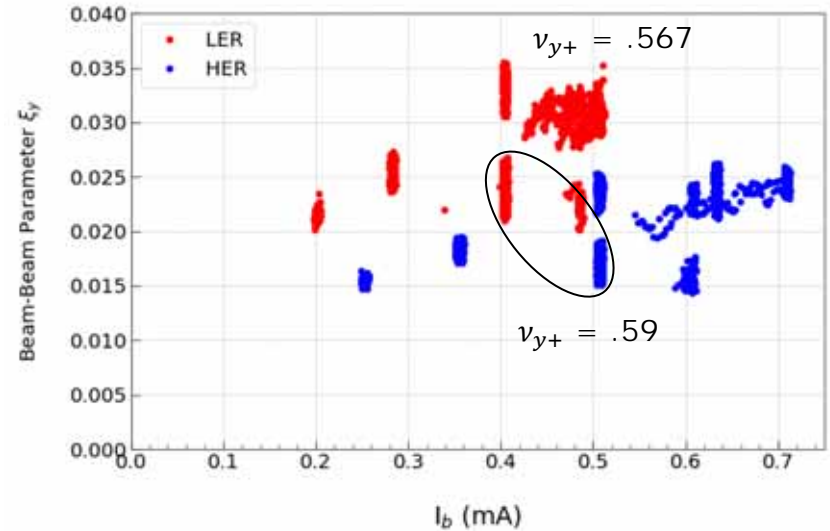

LER Beam Is Blowup Easily. LER Is Weaker than HER.
LER Vertical Tune Helps to Suppress LER Blowup.

Beam-Beam Parameter (Crab Waist OFF): $\xi_{y-} \sim 0.026$

2024a HBC data is consistent with 2019 data.

Physics Run 2022 (Crab Waist ON): $\xi_y = 0.028$

D. Zhou et al., Phys. Rev. Accel. Beams 26, 071001 (2023)

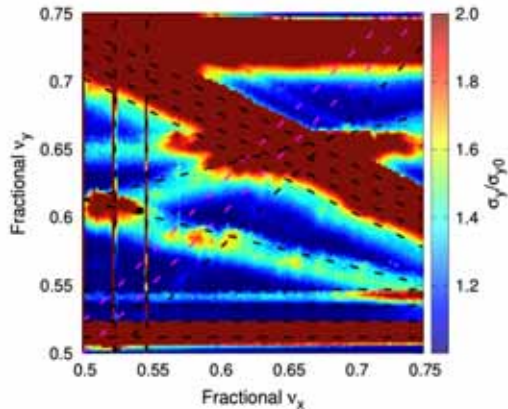
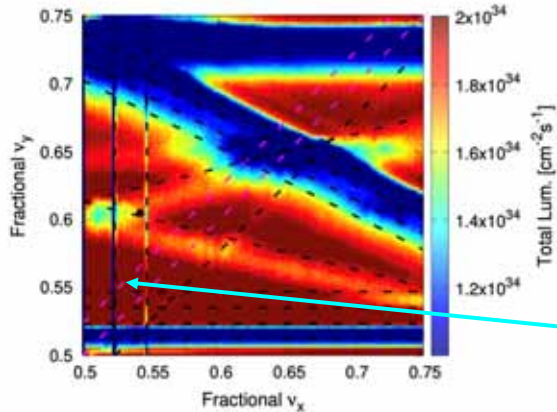

$$\nu_x + 4(\nu_y + \xi_y) = N$$

Beam-Beam Resonance

Better Working Point at Higher Bunch Current Collision

Chromatic X-Y Coupling Resonance

This Resonance is Weak. → Rotating Sextupoles "Fine Tuning"

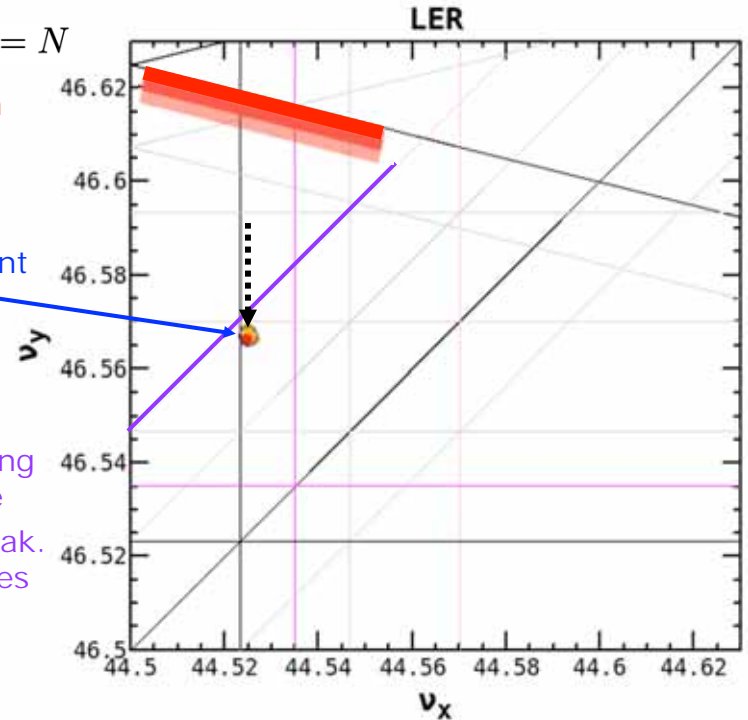

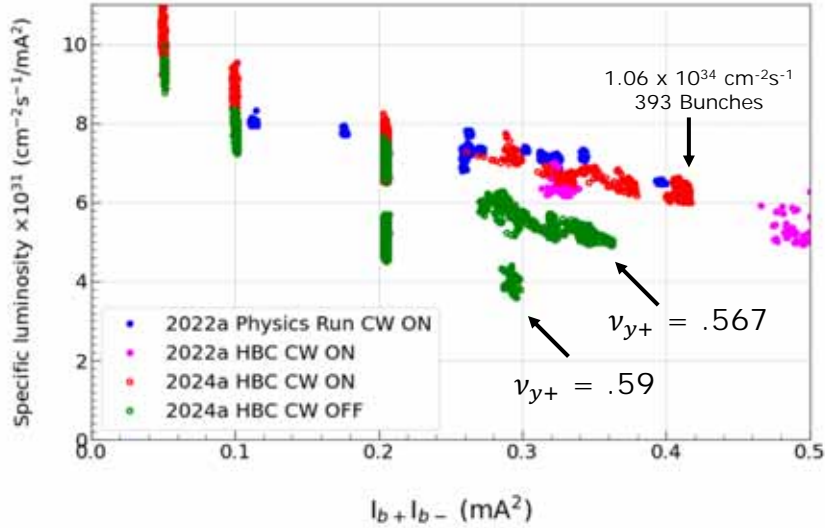

March 21, 2024: CW 80 %(LER) / 40 %(HER)

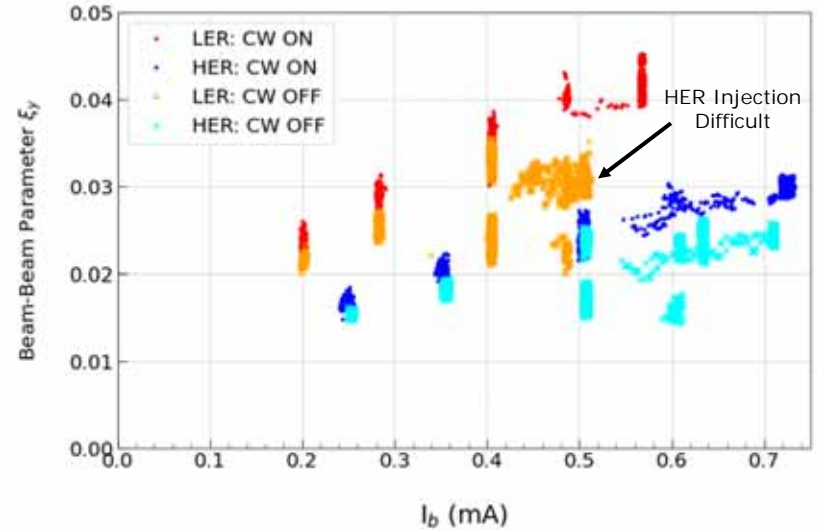

Crab Waist Improves Specific Luminosity at Higher Bunch Current Product.

Vertical Tune Dependence of "CW ON" Is Weaker than "CW OFF".

Beam-Beam Parameter (CW ON): $\xi_{y-} = 0.031$ at $I_{b+} = 0.72$ mA \leftrightarrow 0.026 (CW OFF)

2024a Data (CW ON) Is Consistent with 2022a Data (CW ON).

- **New Tools:**
- Horizontal Aperture Measurement
- Injection Kickers (Balance of Two Kickers)
- Vertical Aperture Measurement
- Vertical Kicker
- HER Only
- Momentum Acceptance Measurement
- RF Longitudinal Kicker
- LER or HER

Vertical Kicker in HER K. Kodama, T. Naito, H. Kaji, et al.



RF Longitudinal Kicker K. Kobayashi, S. Ogasawara, et al.

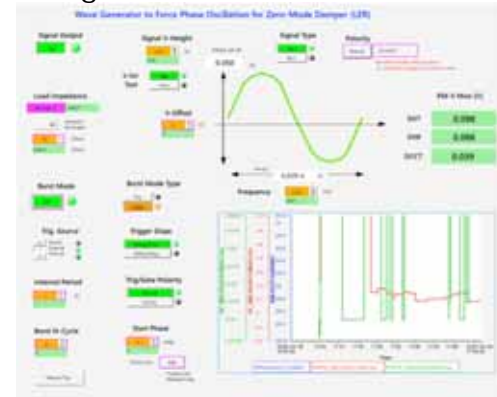

Fit Horizontal/Vertical Oscillation

$$x(n) = \sqrt{2J_x\beta_x} \cos(2\pi\nu_x n + \phi_0)$$

β_x : Model

Horizontal

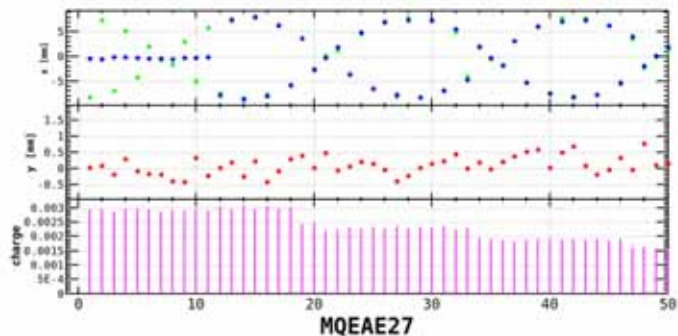

Vertical

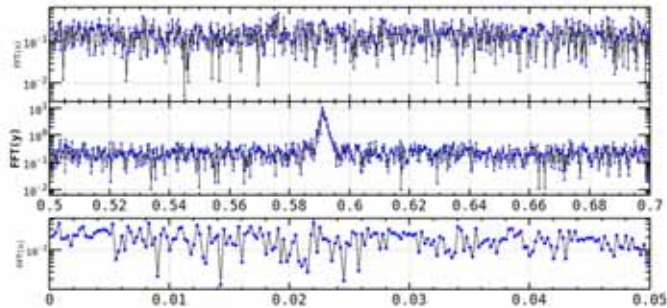
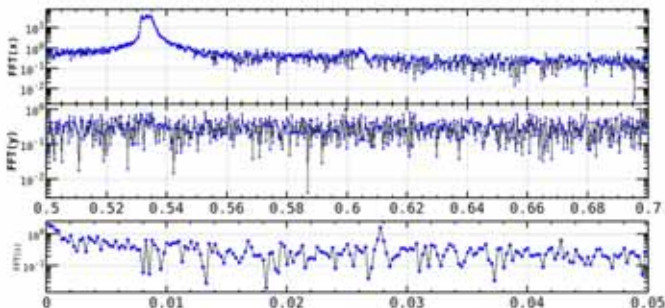
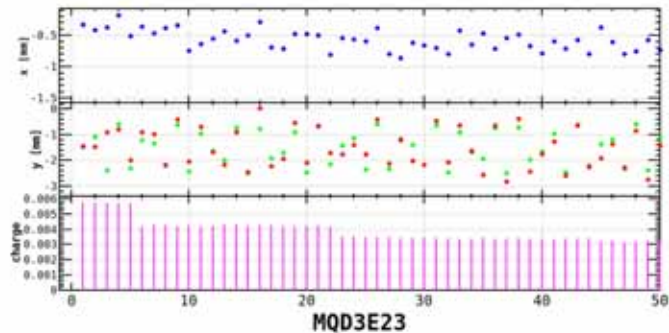

HER RF Kick

$$\beta_y^* = 8\text{mm}$$

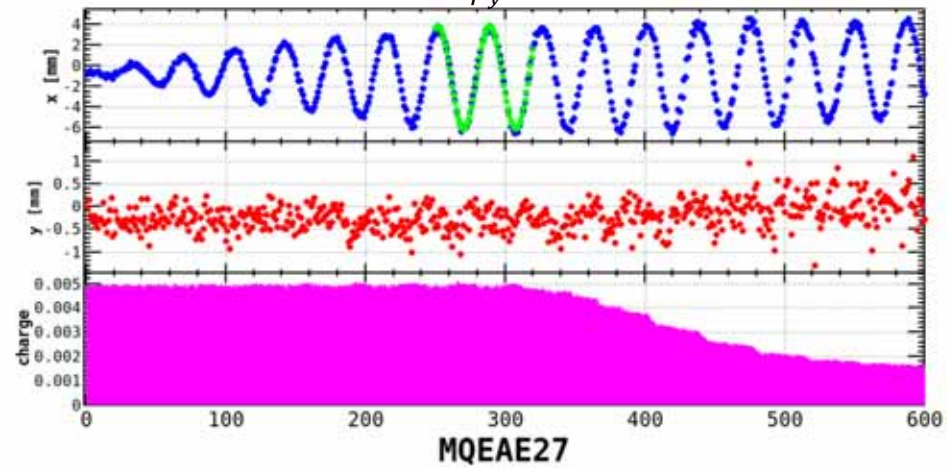

$$\Delta p/p_0 = 0.69\%$$

LER RF Kick

$$\beta_y^* = 1\text{mm}$$

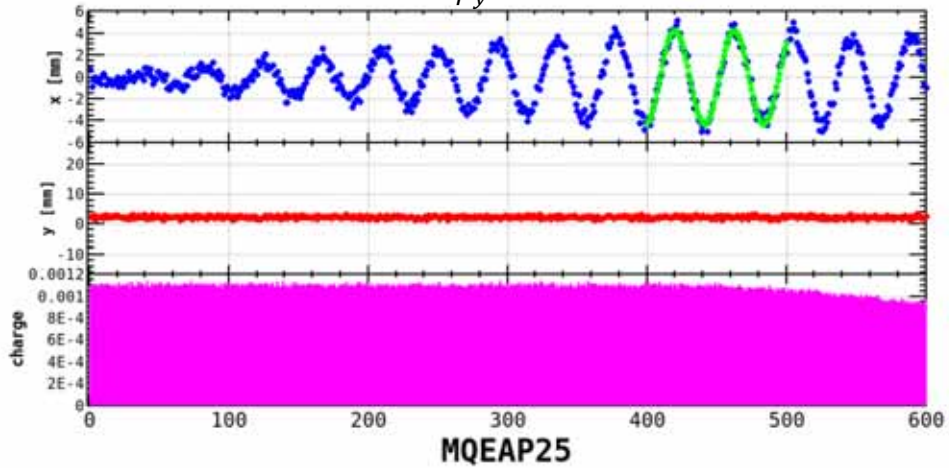

$$\Delta p/p_0 = 0.61\%$$

Plan of 2024b

Machine Parameters

	LER	HER	LER	HER	LER	HER	
	4.0	4.6	4.0	4.6	4.0	4.6	nm
	1321	1099	2080	1480	2750	2200	mA
	2249		2346		2346		
	0.587	0.489	0.89	0.63	1.17	0.94	mA
Horizontal size σ_x^*	17.9	16.6	17.9	16.6	17.9	16.6	μm
Vertical cap sigma Σ_y^*	0.303		0.217		0.178		μm
Vertical size σ_y^*	0.215		0.154		0.126		μm
Betatron tunes ν_x / ν_y	44.525 / 46.589	45.532 / 43.573	44.525 / 46.589	45.532 / 43.573	44.525 / 46.589	45.532 / 43.573	
β_x^* / β_y^*	80 / 1.0	60 / 1.0	80 / 0.8	60 / 0.8	80 / 0.6	60 / 0.6	mm
σ_z	4.6	5.1	6.5	6.4	6.5	6.4	mm
	10.7	12.7	10.7	12.7	10.7	12.7	
	80	40	80	80	80	80	%
Beam-Beam ξ_i	0.0407	0.0279	0.0444	0.0356	0.0604	0.0431	
	7.21×10^{31}		7.62×10^{31}		9.31×10^{31}		$\text{cm}^{-2}\text{s}^{-1}/\text{mA}^2$
	4.65×10^{34}		1×10^{35}		2.4×10^{35}		$\text{cm}^{-2}\text{s}^{-1}$

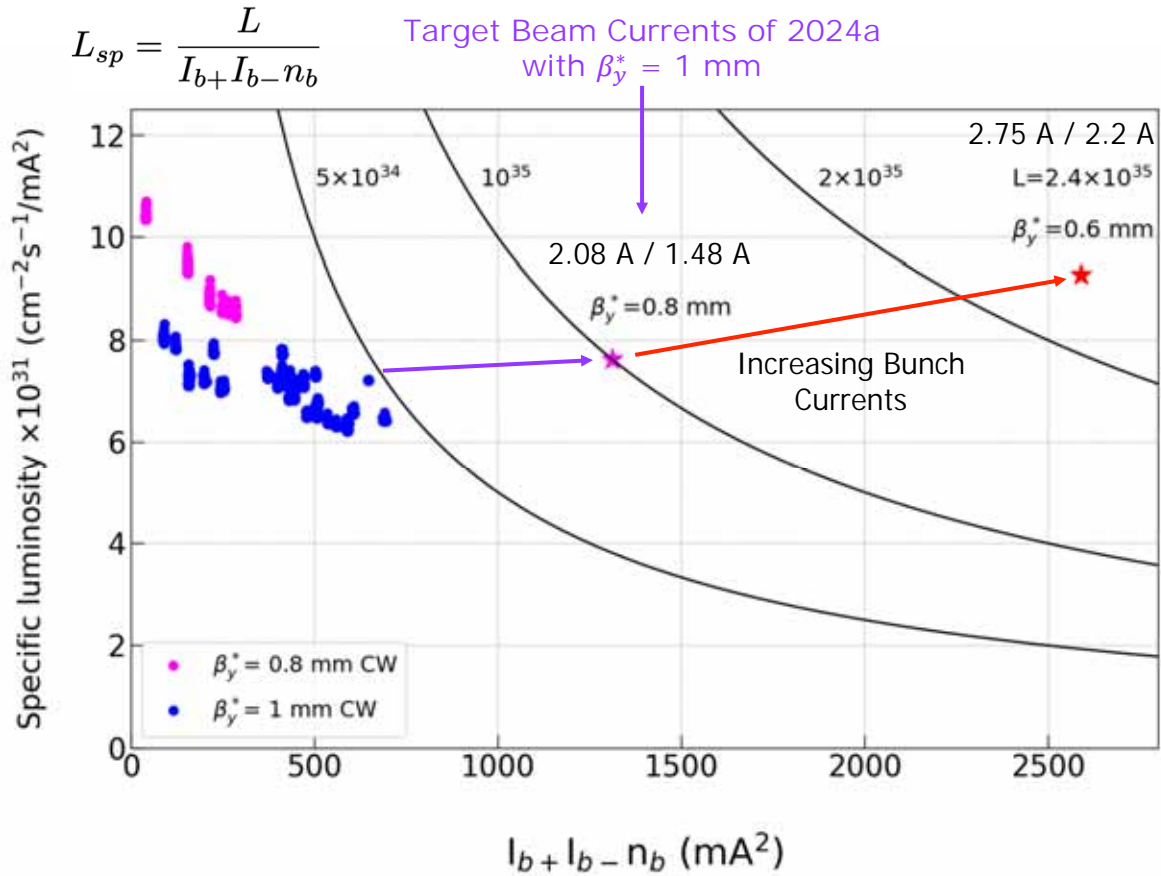

- Vertical Emittance of Single Beam Is Better than 2022ab Run.
- Luminosity Performance Reaches the Same Level as 2022ab Run.
 - $L_{sp} = 6.5 \times 10^{31} \text{ cm}^{-2}\text{s}^{-1}/\text{mA}^2$ at $I_{b+}I_{b-} = 0.41 \text{ mA}^2$ ($I_{b+} = 0.72 \text{ mA}$)
 $L = 6.5 \times 10^{31} \times 0.41 \times 2346 = 6.25 \times 10^{34} \text{ cm}^{-2}\text{s}^{-1}$
- Plan of 2024b Run
 - $\beta_y^* = 1 \text{ mm}$ Operation Will Be Continued to Achieve $6\text{-}8 \times 10^{34} \text{ cm}^{-2}\text{s}^{-1}$.
 - LER: 2 A / HER: 1.4 A / 2346 Bunches
 - $\beta_y^* = 0.8 \text{ mm}$ Will Be Adopted in June After Above Achievement.
 - Injection Will Constrain Beam Currents.
 - Two-Bunch Injection, 25 Hz Repetition, Sextupole Optimization (Enlarge DA), Synchrotron Phase Space Injection (HER), Investigation of Narrow Vertical Aperture (HER), etc.

- We plan to operate SuperKEKB rings at least 4.5 months for JFY2024.
 - 2024a 29/Jan to 31/Mar, 2024b 1/Apr to 1/Jul. 2024c 9/Oct to end of Nov.??
 - Hoping to receive supplemental operation budget to enable longer operation, especially on Mar/2025.
- Accelerator works of Long shutdown 1 were completed almost on schedule and resumed the beam operation.
- Many machine developments with international collaborators (especially young collaborators) are undergoing. We welcome your participation!



Backup slides



JFY2024 SuperKEKB operation plan

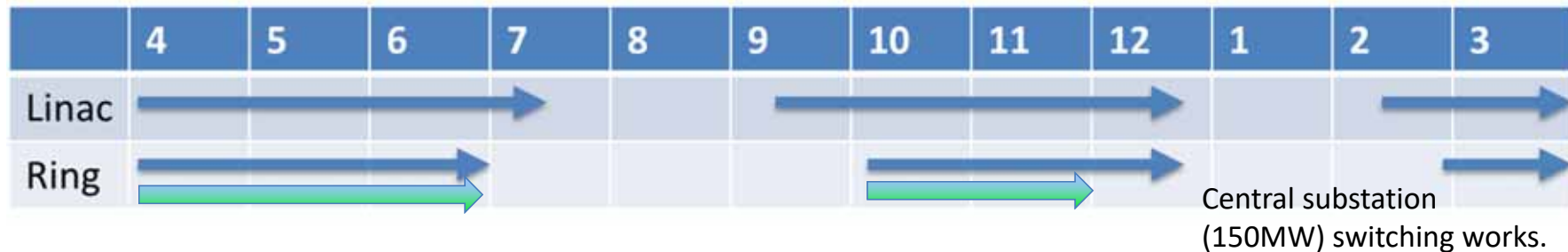

- With the initial budget allocated by MEXT, it seems likely that the rings will only be able to operate for three months until July (due to huge electricity costs).
- With additional operating budget by KEK, we will be able to operate the rings after summer, maybe 1.5 months.
- If there is a supplemental budget from MEXT, it will be possible to operate in March (and probably in December).

■ Re-tried on 23/Oct/2023 with

- Modified RVC gear
- Modified VXD cable support
- The QCS supports were carefully advanced by Tanaka-san.

■ RVC worked very smoothly no vacuum leak found.

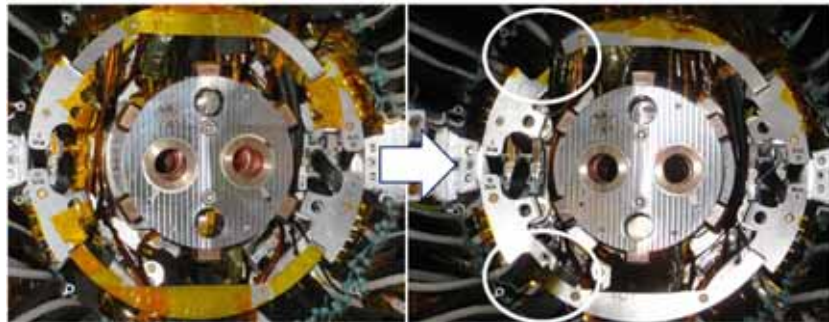

Status of LER collimator

Name	Type	Tip Material (): longitudinal length in mm	Tip Condition	Remarks
D06H3	SuperKEKB	Cu coated C (160)	healthy	spoiler against inj. kickers' accidental firings
D06H4	SuperKEKB	Ta (10)	healthy	absorber against inj. kickers' accidental firings
D03H1	SuperKEKB	W (10)	healthy	
D02H1	SuperKEKB	W (10)	healthy	
D02H2	SuperKEKB	W (10)	healthy	
D02H3	SuperKEKB	W (10)	healthy	
D02H4	SuperKEKB	W (10)	healthy	
D06V1	SuperKEKB	Cu coated Ti (10)	healthy	
D06V2	SuperKEKB	hybrid (3)	healthy	
D05V1	SuperKEKB	Cu coated Ta (4)	healthy	
D02V1	SuperKEKB	Cu coated Ta (10)	healthy	

Status of HER collimator

Name	Type	Tip Material (): longitudinal length in mm	Tip Condition	Drive Mechanism	Remarks
D09H1	KEKB	Cu coated Ti (40)	damaged		
D09H2	KEKB	Cu coated Ti (40)	damaged		
D09H3	KEKB	Cu coated Ti (40)	damaged		
D09H4	KEKB	Cu coated Ti (40)	damaged		
D12H1	KEKB	Ti (40)	healthy		
D12H2	KEKB	Cu coated Ti (40)	damaged		
D12H3	KEKB	Ti (40)	healthy		
D12H4	KEKB	Cu coated Ti (40)	healthy		
D01H3	SuperKEKB	W (10)	healthy	-	
D01H4	SuperKEKB	W (10)	healthy	-	
D01H5	SuperKEKB	W (10)	healthy	-	
D09V1	KEKB	Cu coated Ti (40)	healthy	upgraded	
D09V2	KEKB	Cu coated Ti (40)	healthy		
D09V3	KEKB	Cu coated Ti (40)	healthy		
D09V4	KEKB	Cu coated Ti (40)	healthy		
D12V1	KEKB	Cu coated Ti (40)	damaged	upgraded	
D12V2	KEKB	Cu coated Ti (40)	damaged		
D12V3	KEKB	Cu coated Ti (40)	healthy	upgraded	
D12V4	KEKB	Cu coated Ti (40)	healthy	upgraded	
D01V1	SuperKEKB	Cu coated Ta (10)	healthy	-	

Spare jaws

Tip Material (): longitudinal length in mm	Collimator to be installed (assumed)	Remarks
HER vertical: Cu coated Ta (10)	D01V1	Plan to deliver in this fiscal year.
HER vertical: Cu coated Ta (10)	D01V1	Plan to deliver in this fiscal year.
HER vertical: Cu coated Ti (40)	D09V1-V4, D12V1-V4	
HER vertical: Cu coated Ti (40)	D09V1-V4, D12V1-V4	
LER vertical: Cu coated Ta (10)	D02V1	
LER vertical: Cu coated Ta (10)	D02V1	
LER vertical: hybrid (3)	D05V1, D06V1-V2	
LER vertical: hybrid (3)	D05V1, D06V1-V2	
LER vertical: Cu coated Ta (10)	D02V1, D05V1, D06V1-V2	Plan to deliver in this fiscal year.
LER vertical: Cu coated Ta (10)	D02V1, D05V1, D06V1-V2	Plan to deliver in this fiscal year.
LER horizontal: Ta (10)	D06H4	