



Francesco Chiapponi
University and INFN Bologna

**on behalf of the RD_FCC
collaboration**

8-11 April 2024
Marseille

μ -Rwell technology for the IDEA detector

**2024 European Edition of the International
Workshop on the Circular Electron-Positron
Collider**



IDEA detector layout

IDEA is a general-purpose detector designed for experiments at future e^+e^- colliders.

The **preshower** detector and the **muon system** are designed to be instrumented with **μ -Rwell technology**.

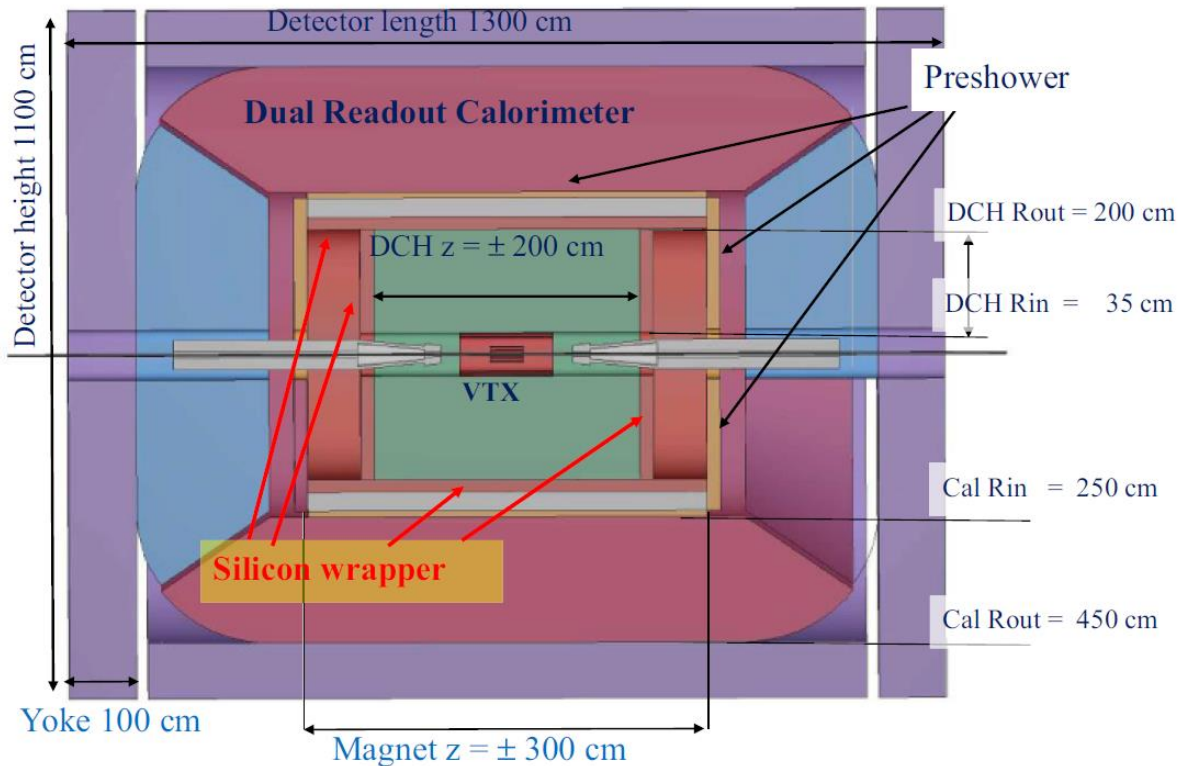

Muon System: 3 layers of μ -Rwell

Dual-readout calorimeter: $2m$, $7\lambda_{int}$

Preshower: $\sim 1 X_0$

Outer Silicon wrapper: Si strips

Superconducting solenoid coil: 2T,
 $R \sim 2.1 - 2.4$ m,
 $0.74X_0$, $0.16\lambda @ 90^\circ$

Drift Chamber:
 112 layers, 4m long,
 $R = 35 - 200$ cm,
 $1.6-5\% X_0$

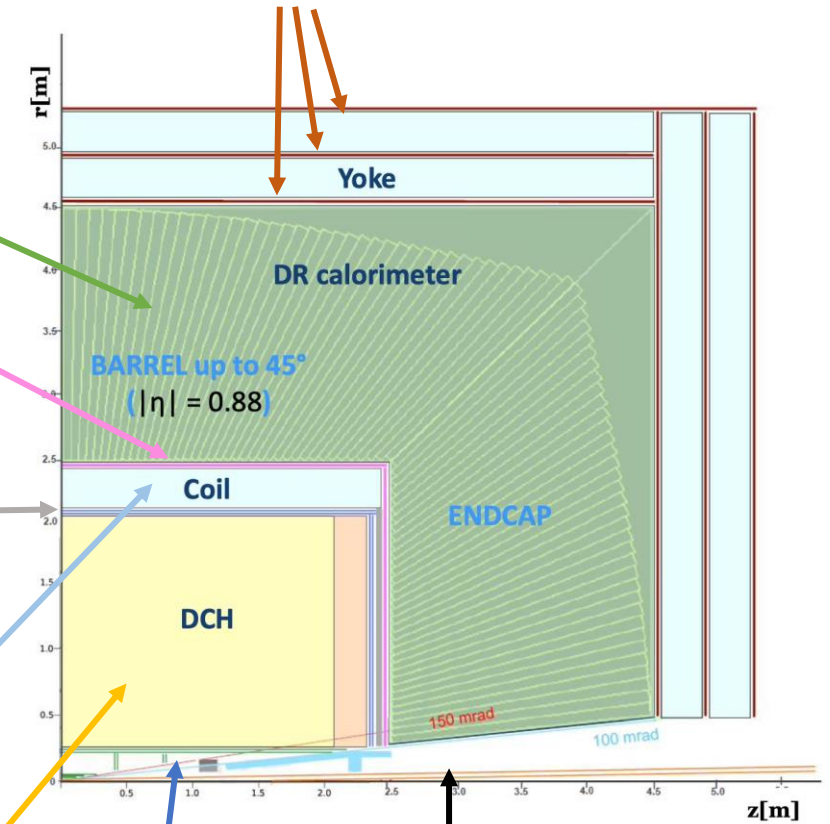

VERTEX: 5 MAPS layers
 $R = 1.2 - 34$ cm

μ-Rwell technology

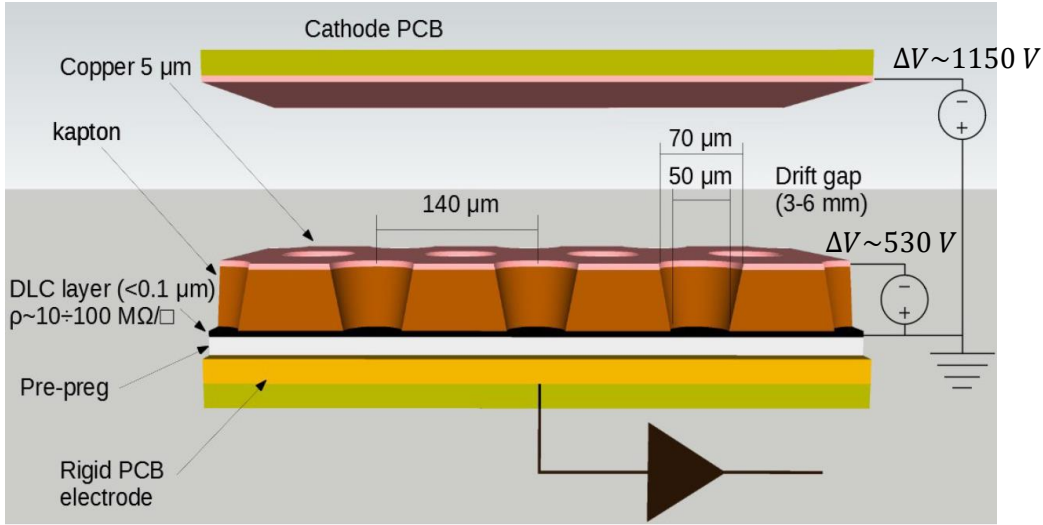

The *micro-Resistive well* is a resistive MPGD composed of two elements:

1. Cathode

2. μ-Rwell PCB

- a **WELL** patterned **Kapton foil** acting as amplification stage
- a resistive Diamond-Like Carbon (**DLC**) layer,
 $\rho \sim 50 \div 100 \text{ M}\Omega/\square$
- a standard **readout PCB** with **pad** or **strip** segmentation

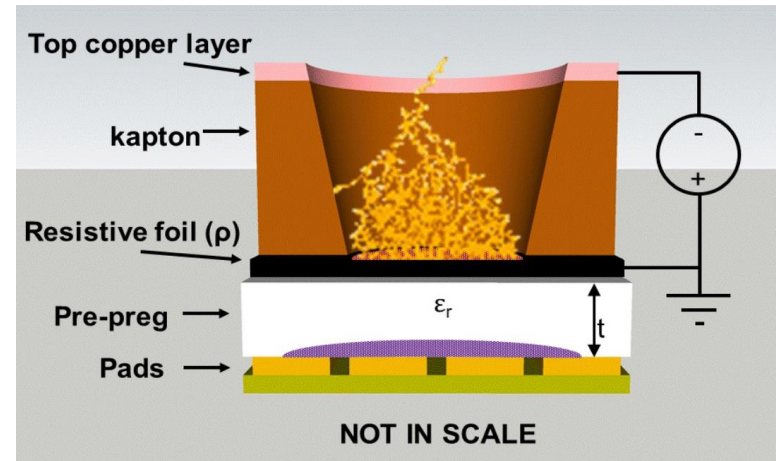
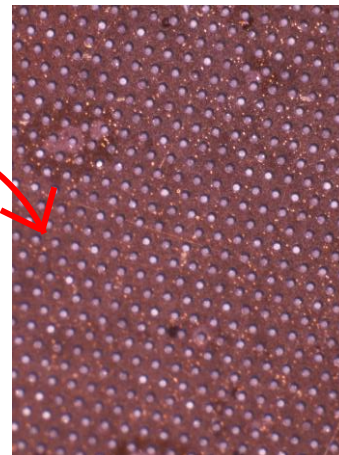
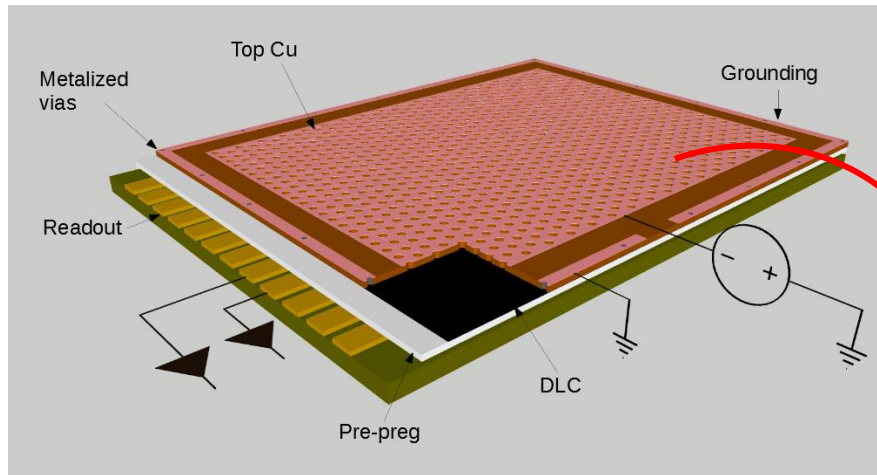

The **well** acts as a multiplication channel for the ionization produced in the drift gas gap

The **resistive** stage ensures the spark amplitude quenching

G. Bencivenni et al., *The micro-Resistive WELL detector: a compact spark-protected single amplification-stage MPGD*, 2015 JINST 10 P02008

IDEA's preshower

Barrel Preshower

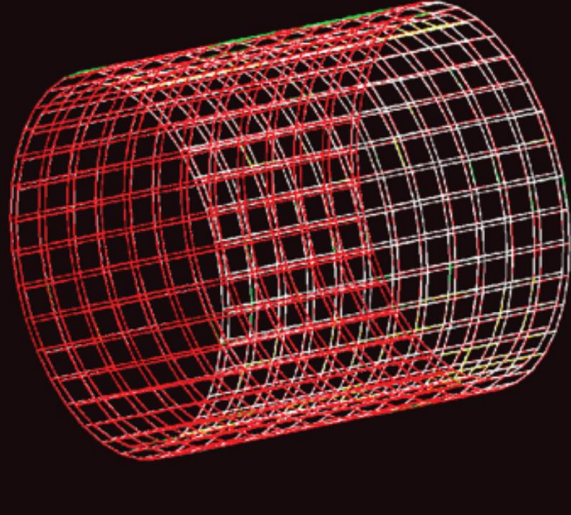

Endcap Preshower

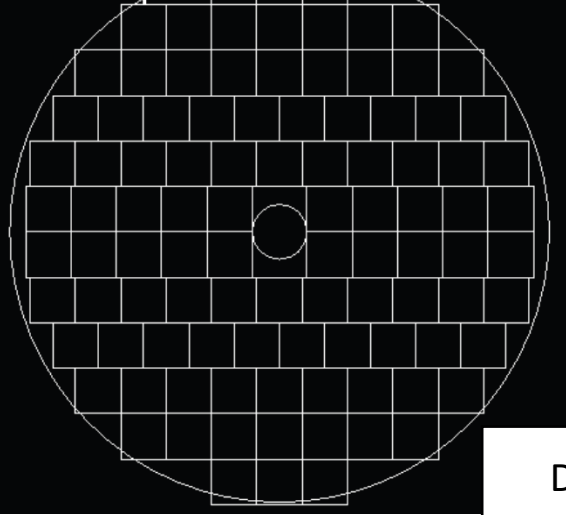

Provides **high spatial resolution after the magnet** to improve cluster reconstruction

Foreseen readout:

- Strip pitch: 0.4 mm
- Strip length: 50 cm
- **Area : 130 m²**
- Channels: 1.3 M

Requirements:

- Efficiency > 98%
- Spatial resolution < 100 μm

Studies under simulation

Detector technology:
 μ -Rwell

50x50 cm² tiles with X-Y readout

Layout simulated in DD4HEP

Example of detector sector made of square μ Rwell tiles overlapped to minimise dead area

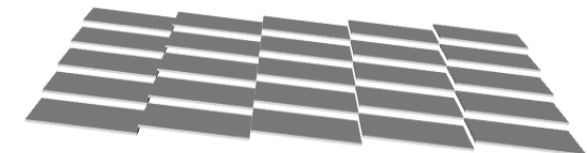
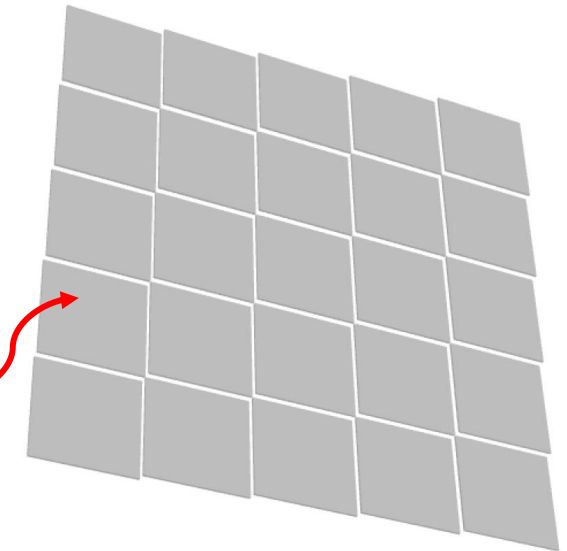

IDEA's muon detector

Identifies muons and searches for LLPs

Foreseen readout:

- Strip pitch: 1.2 mm
- Strip length: 50 cm
- **Area : 1530 m² [*]**
- Channels: ~5 M

Studies under simulation

Detector technology:
 μ -Rwell

50x50 cm² tiles with X-Y readout

Requirements:

- Efficiency > 98%
- Spatial resolution < 400 μ m



[*] Need for mass production \Rightarrow Technology Transfer to Industry

Layout simulated in DD4HEP

To cover the entire volume may be necessary to use blocks of different size

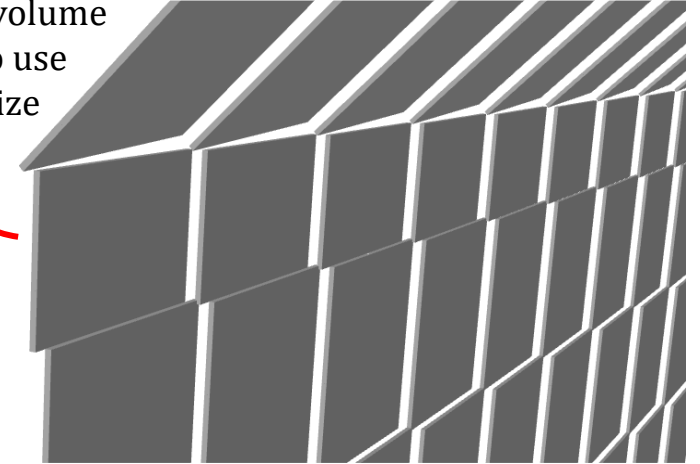

Iron yokes

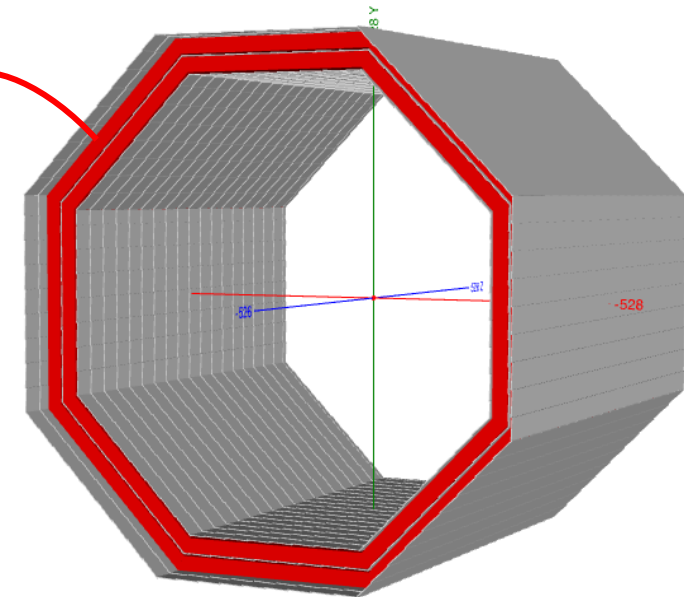

μ -Rwell technology: readout with TIGER electronics

- [TIGER ASIC](#): developed for BESIII CGEM-IT
- First tests:
 - First working setup installed and **tested with $10 \times 10 \text{ cm}^2$ μ -Rwell** prototype
 - 64 channels
 - Noise level very low ($\sim 1 \text{ fC}$)
- APV25 used for R&D waiting for TIGER



Distribution of thresholds of an entire chip (64 channels)

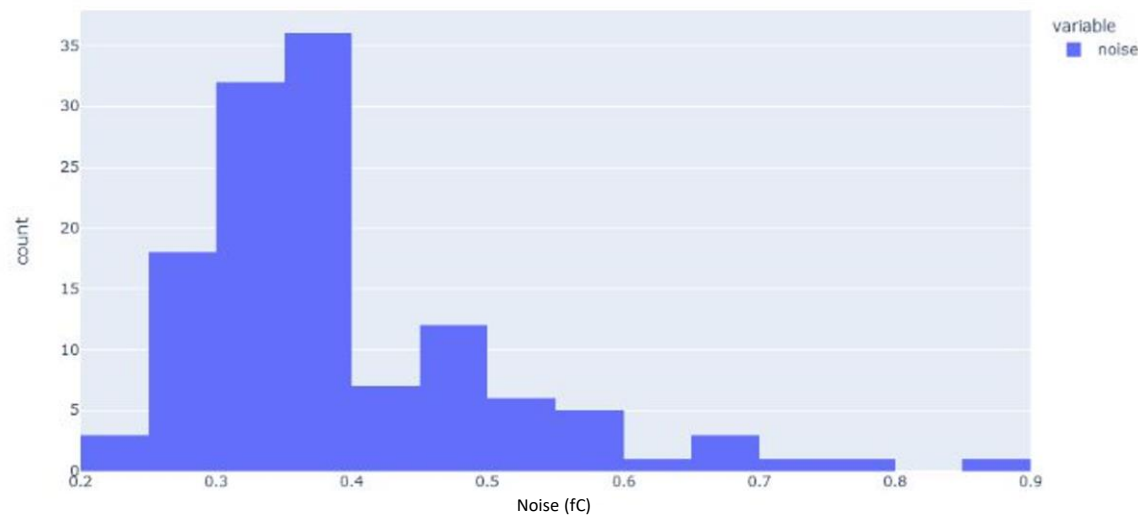

Courtesy of R. Farinelli

Measured performance of the TIGER ASIC.

Parameters	Values
Input charge	5-55 fC
TDC resolution	30 ps RMS
Time-walk (5-55 fC range)	12 ns
Average gain	10.75 mV/fC
Nonlinearity (5-55 fC range)	0.5%
RMS gain dispersion	3.5%
Noise floor (ENC)	1500 e^-
Noise slope	10 e^- /pF
Maximum power consumption	12 mW/ch

Test beam results with APV25 : 1D μ -Rwell

2021 - Resistivity scan at fixed pitch

- Active area = 400x50 mm²
- Resistivity = 10-80 M Ω /□
- Strip pitch = 0.4 mm
- Strip width = 0.15 mm
- Pitch/width ratio = 2.66

⇒ Same performance for the 20 – 80 M Ω /□
Efficiency knee at 550 V, $\sigma_x < 100 \mu\text{m}$

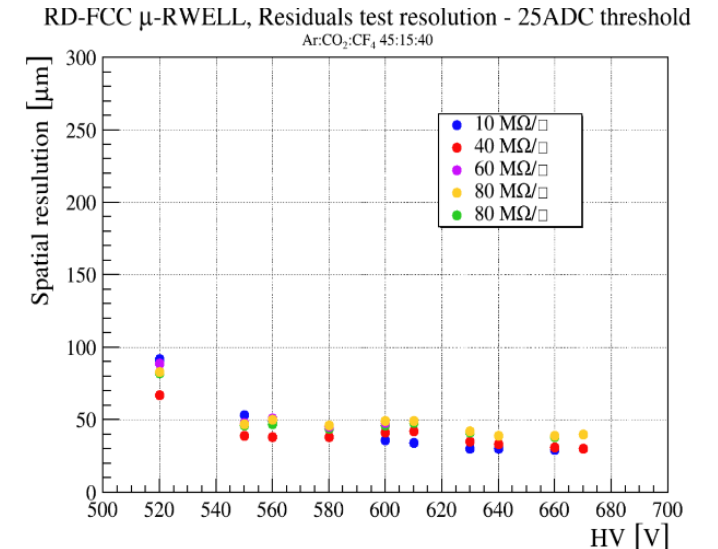
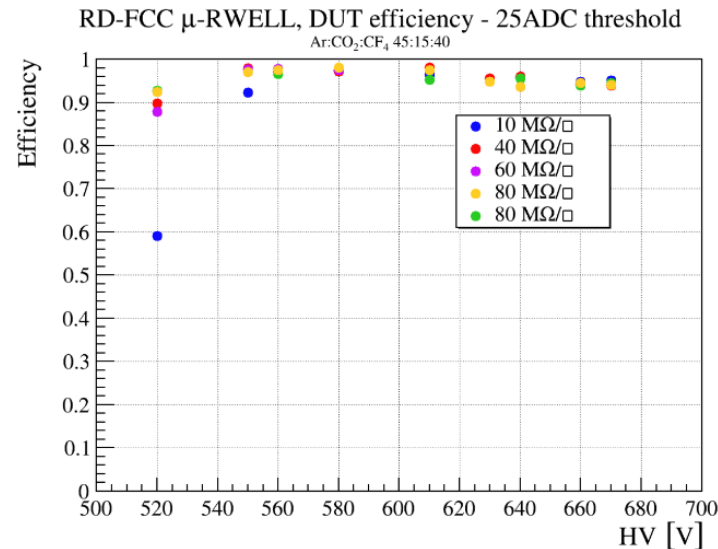
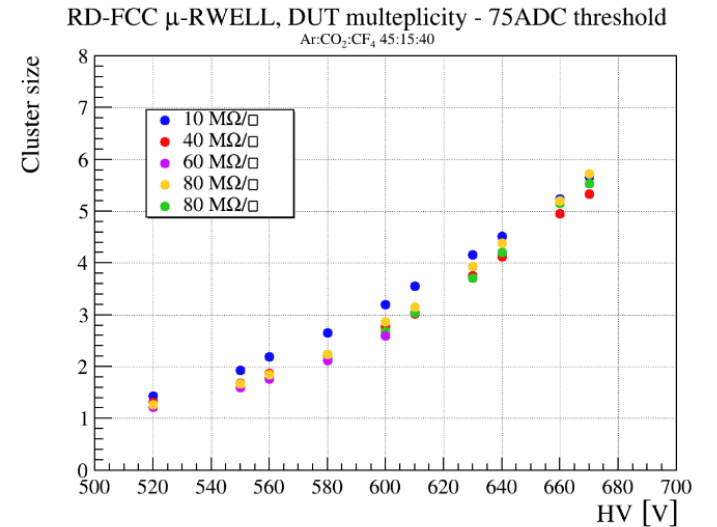
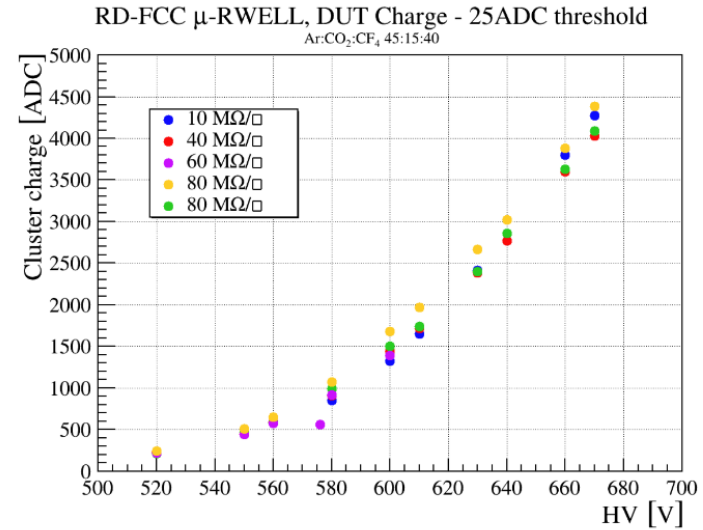

Farinelli, Riccardo. (2022). The u-RWELL technology at the IDEA detector. 333. 10.22323/1.414.0333.

Test beam results with APV25 : 1D μ -Rwell

2021 - Resistivity scan at fixed pitch

- Active area = 400x50 mm²
- Resistivity = 10-80 M Ω /□
- Strip pitch = 0.4 mm
- Strip width = 0.15 mm
- Pitch/width ratio = 2.66

⇒ Same performance for the 20 – 80 M Ω /□
Efficiency knee at 550 V, $\sigma_x < 100 \mu\text{m}$

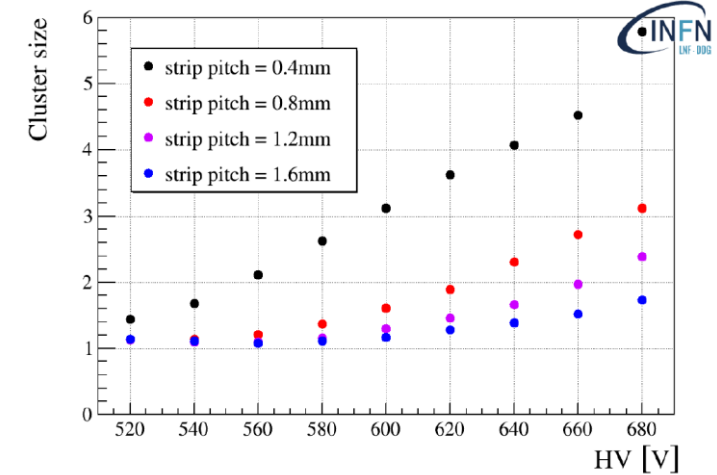
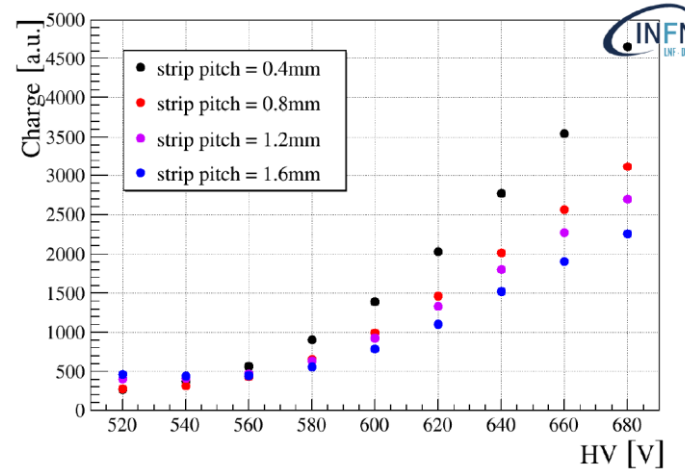

2022 - Pitch scan at fixed resistivity

- Active area = 400x50 mm²
- Resistivity = 30 M Ω /□
- Strip pitch = 0.4-1.6 mm
- Strip width = 0.15 mm
- Pitch/width ratio = 2.66-10.66

⇒ Larger the strip pitch, lower the charge signal requiring a higher gain to reach full efficiency.
Efficiency knee at 600 V, $\sigma_x < 400 \mu\text{m}$
for 1.6 mm pitch

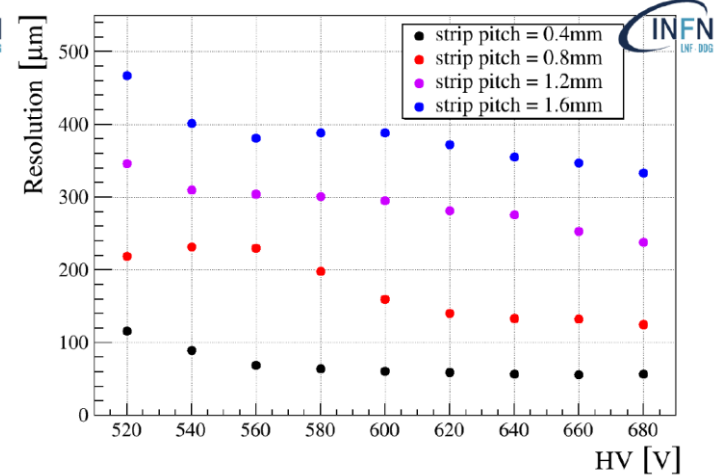
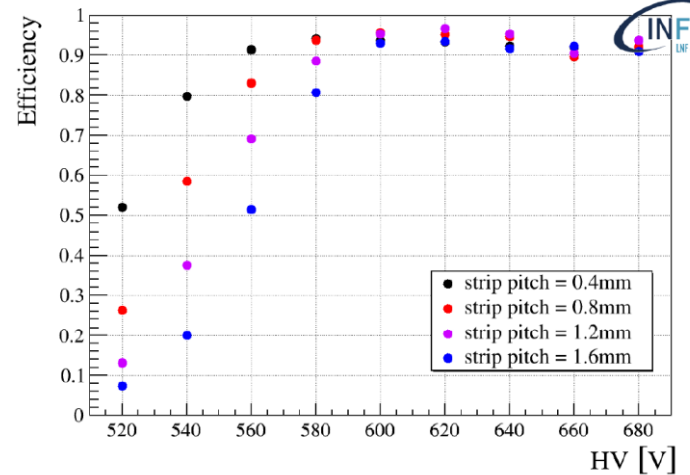

Courtesy of M.Poli Lener

μ -Rwell technology: possible 2D layouts

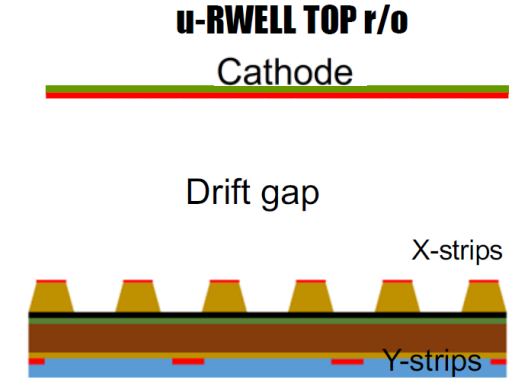
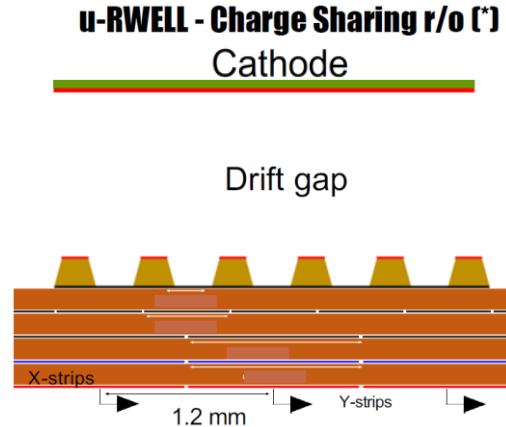
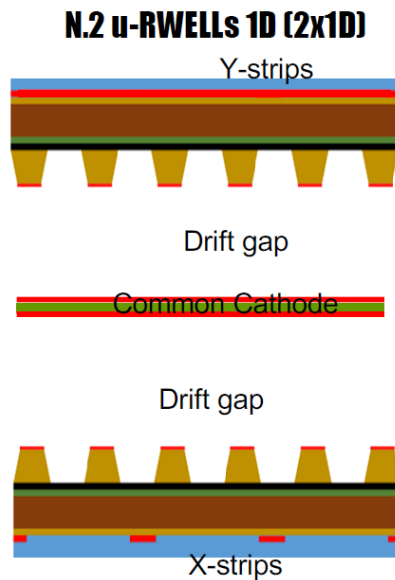
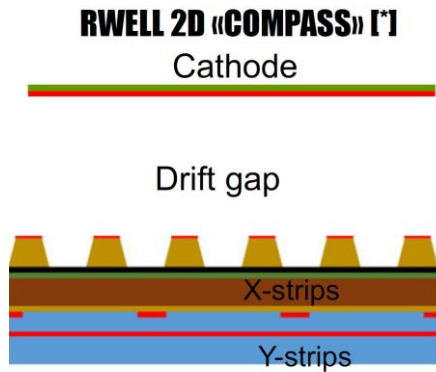

- Good performance
- No easy optimization of the charge sharing on X-Y views
- Requires higher gas gain due to the coupling of the X and Y strips

- Works at lower gas gain wrt the «COMPASS» readout

Charge transfer and charge sharing using capacitive coupling between a stack of layers or pads and the readout board.

- Reduces the FEE channels.
- Total charge divided between X and Y readout (similar to the «COMPASS» readout).

- Works like 2x1D with a lower gas gain
- X-Y readout are decoupled
- X coordinate on the TOP of the amplification stage introduces same dead zone in the active area

(*) Y. Zhou et al. NIMA 927 (2019) 31

(*) K. Gnanvo et al. NIMA 1047 (2023) 167782

μ -Rwell technology: possible 2D layouts

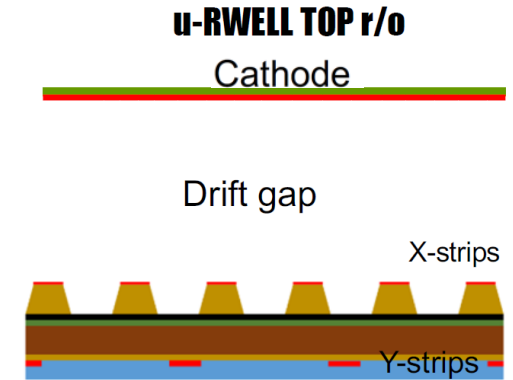
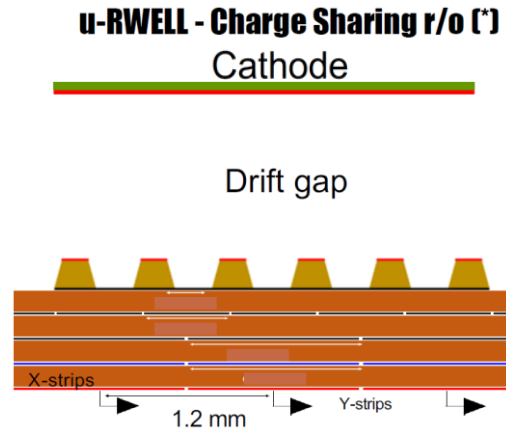
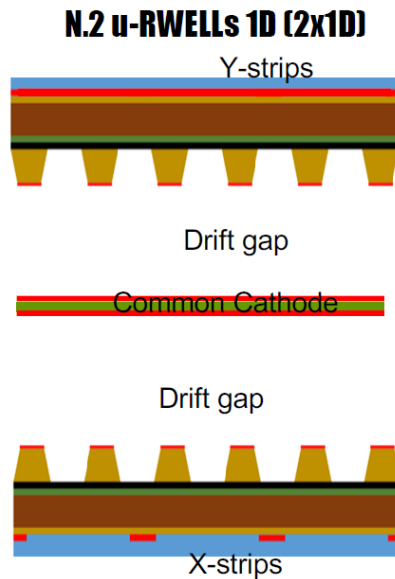
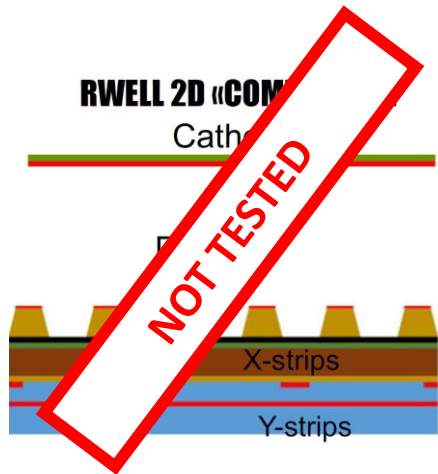

- Good performance
- No easy optimization of the charge sharing on X-Y views
- Requires higher gas gain due to the coupling of the X and Y strips

- Works at lower gas gain wrt the «COMPASS» readout

Charge transfer and charge sharing using capacitive coupling between a stack of layers or pads and the readout board.

- Reduces the FEE channels.
- Total charge divided between X and Y readout (similar to the «COMPASS» readout).

- Works like 2x1D with a lower gas gain
- X-Y readout are decoupled
- X coordinate on the TOP of the amplification stage introduces same dead zone in the active area

(*) Y. Zhou et al. NIMA 927 (2019) 31

(*) K. Gnanvo et al. NIMA 1047 (2023) 167782

Test beam results with APV25 : 2D μ -Rwell

2 x 1D readout

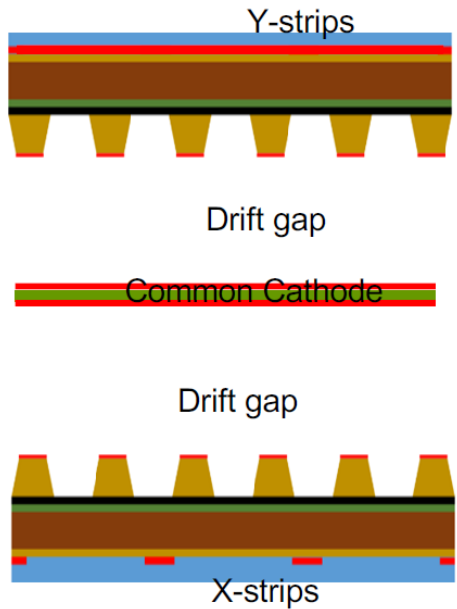

Active area = 100x100 mm²
 Resistivity = 50 M Ω /□
 Strip pitch = 0.76 mm
 Strip width = 0.3 mm
 Pitch/width ratio = 2.53

Efficiency knee at 500 V,
 $\sigma_x < 200 \mu\text{m}$

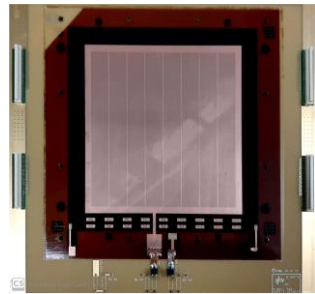
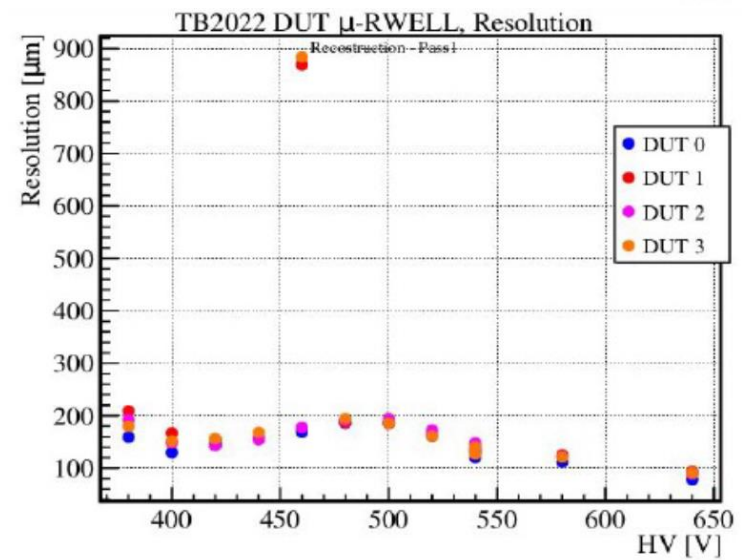
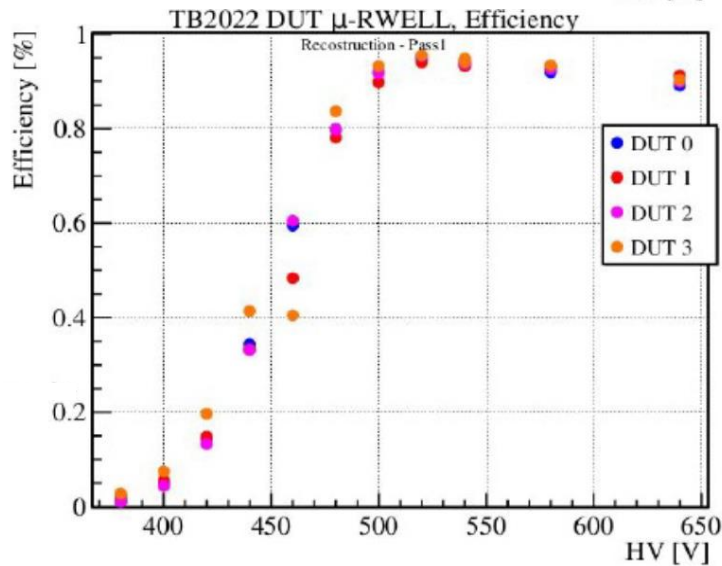
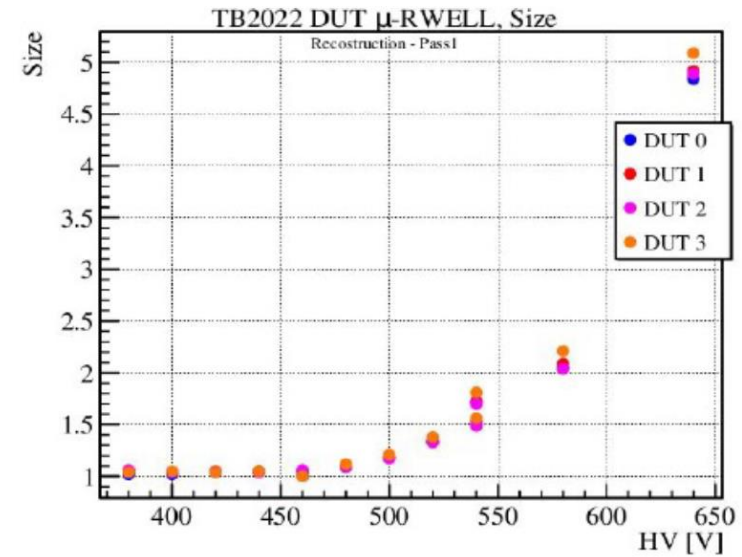
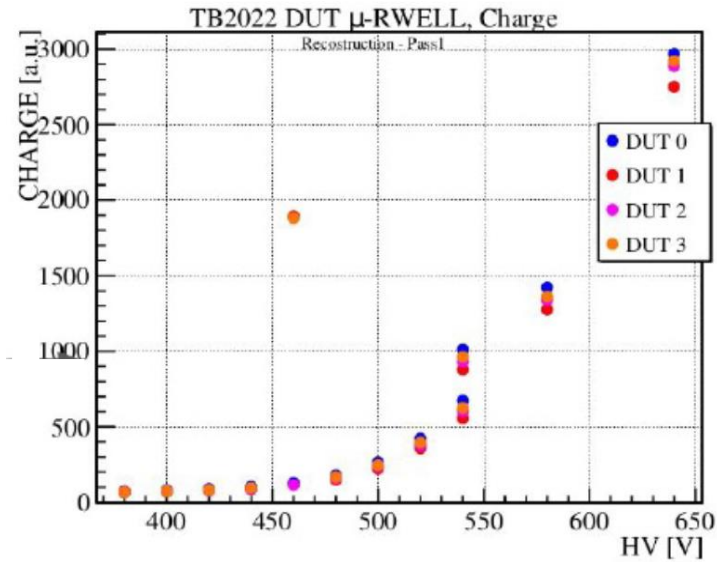

[Courtesy of M.Poli Lener](#)

Test beam results with APV25 : 2D μ -Rwell

Capacitive Sharing readout

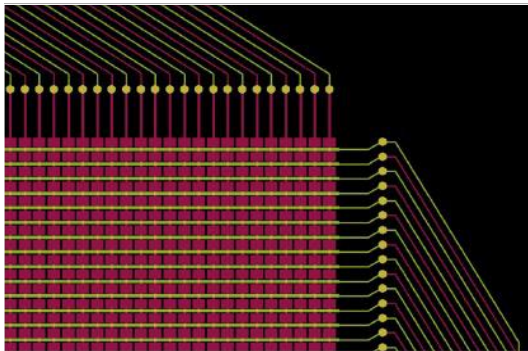
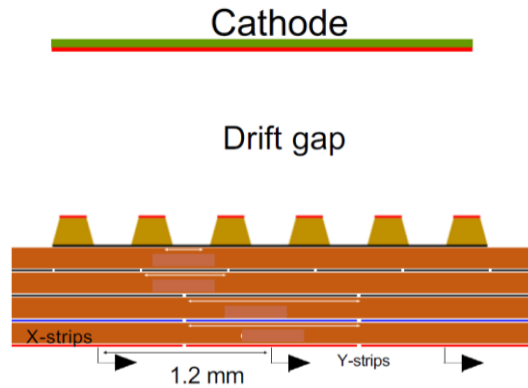

Active area = 100x100 mm²
 Resistivity = 50 M Ω /□
 Strip pitch = 1.2 mm
 Strip width = 1.1 mm
 Dead zone = 0%

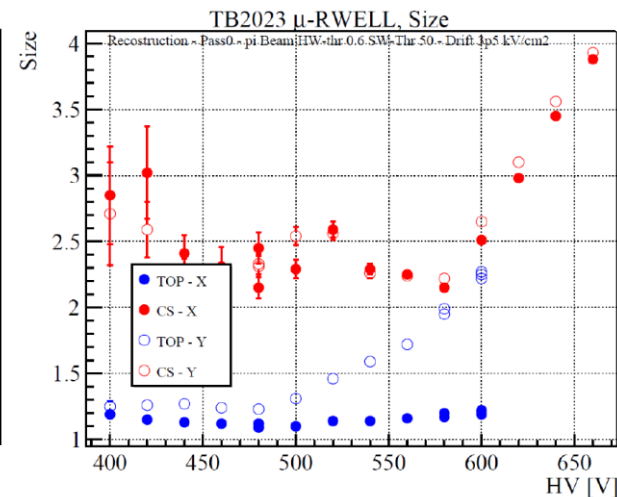
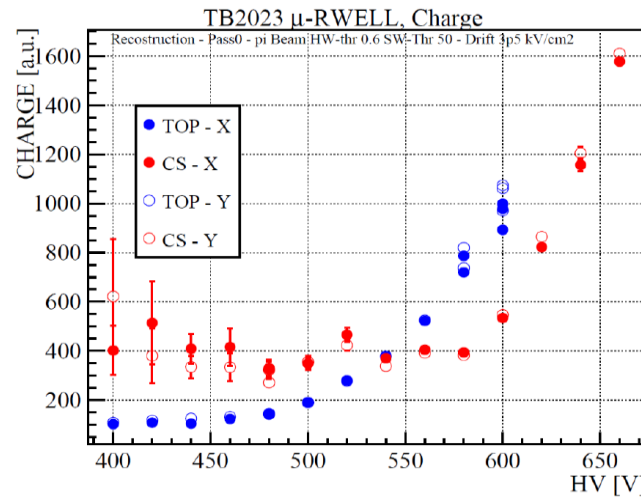

Preliminary results

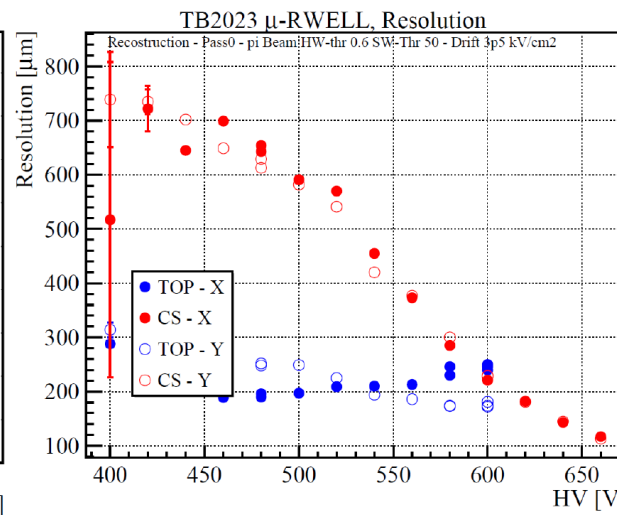
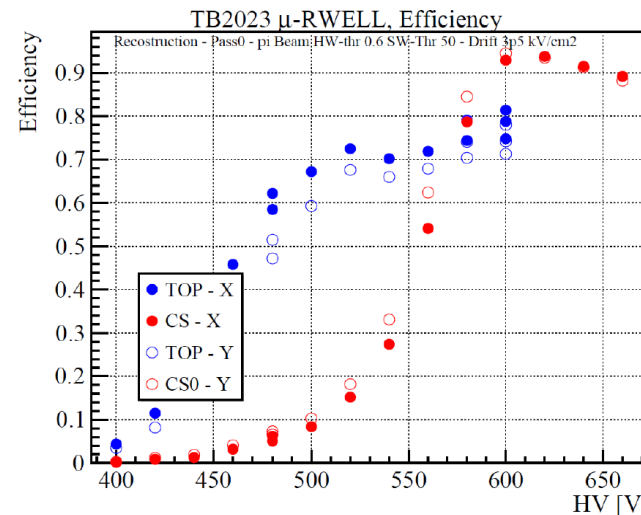

Courtesy of M.Poli Lener

TOP readout

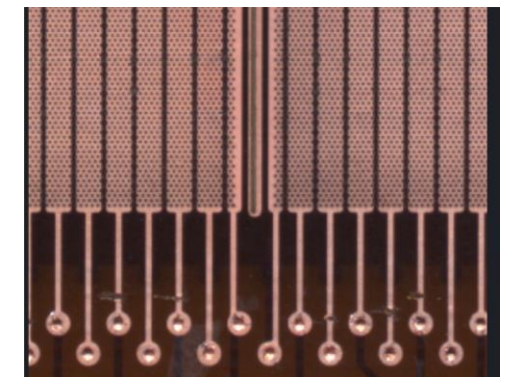
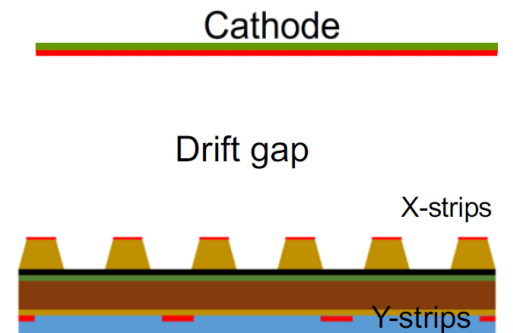

Active area = 100x100 mm²
 Resistivity = 50 M Ω /□
 Strip width = 0.7 mm
 Y Strip pitch = 0.8 mm
 X Strip pitch = 1.5 mm
 Dead zone ~ 15%

Test beam results with APV25 : 2D μ -Rwell

Capacitive Sharing readout

- **Total charge is divided between X and Y views**
- **Cluster size increases up to 4 strips** (proof that the charge sharing mechanism works)

- **Efficiency knee at 600 V**
- **High efficiency plateau (~95%)**
- **Spatial resolution improves at higher gain reaching 150 μm** with a strip pitch of 1.2 mm

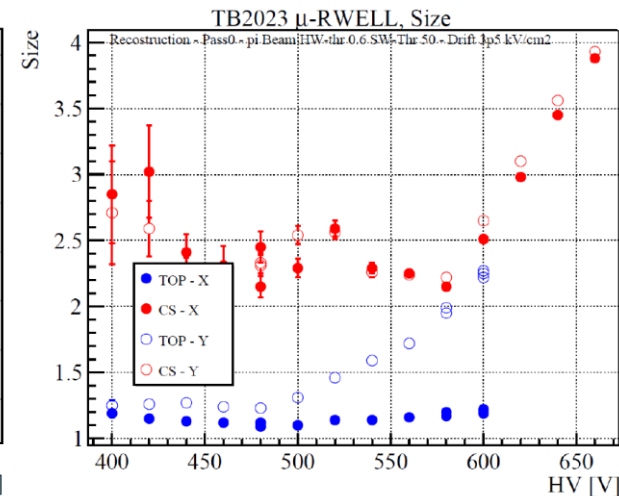
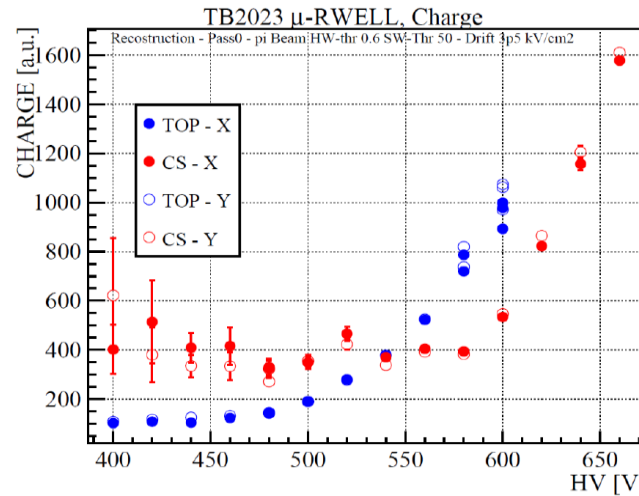

Preliminary results

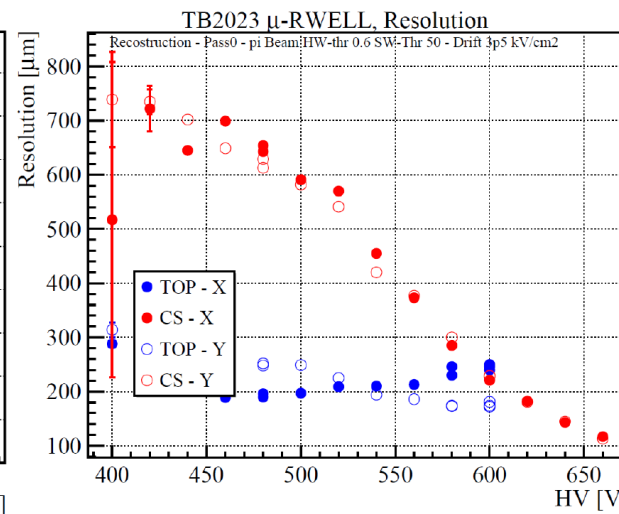
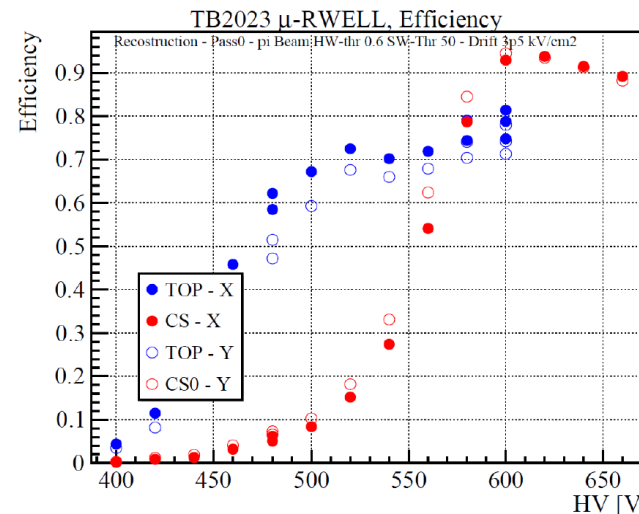

Courtesy of M.Poli Lener

TOP readout

- The **total charge is not divided between X and Y strips**
- **Cluster size does not change on X axis** (TOP layer), while **improves on the Y axis**, due to the DLC spread
- **Efficiency knee at 500 V** (like the 1D prototype)
- **Low efficiency plateau (~70%)** due to the dead area introduced by TOP readout
- **Digital spatial resolution on the X axis** (strip size 1.5 mm), improving on the Y axis

Technology transfer with ELTOS*



- Financed by AIDAInnova and carried on by LNF



DLC Magnetron Sputtering machine co-funded by INFN-CSN1

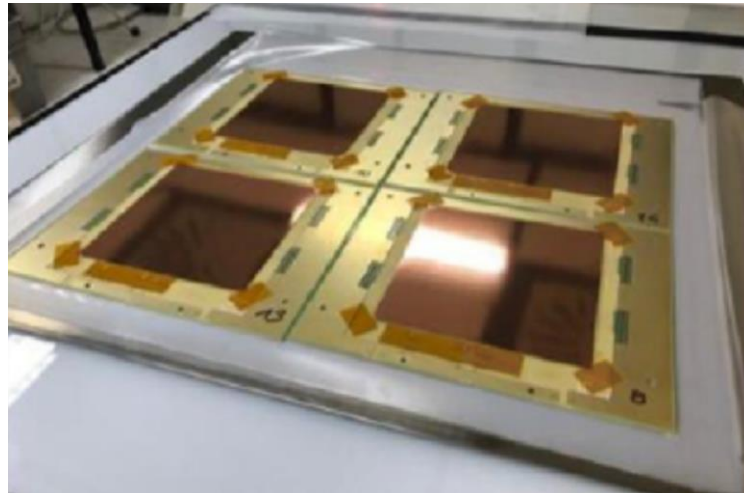

* [Eltos | Circuiti Stampati Professionali](#)

2024 Program

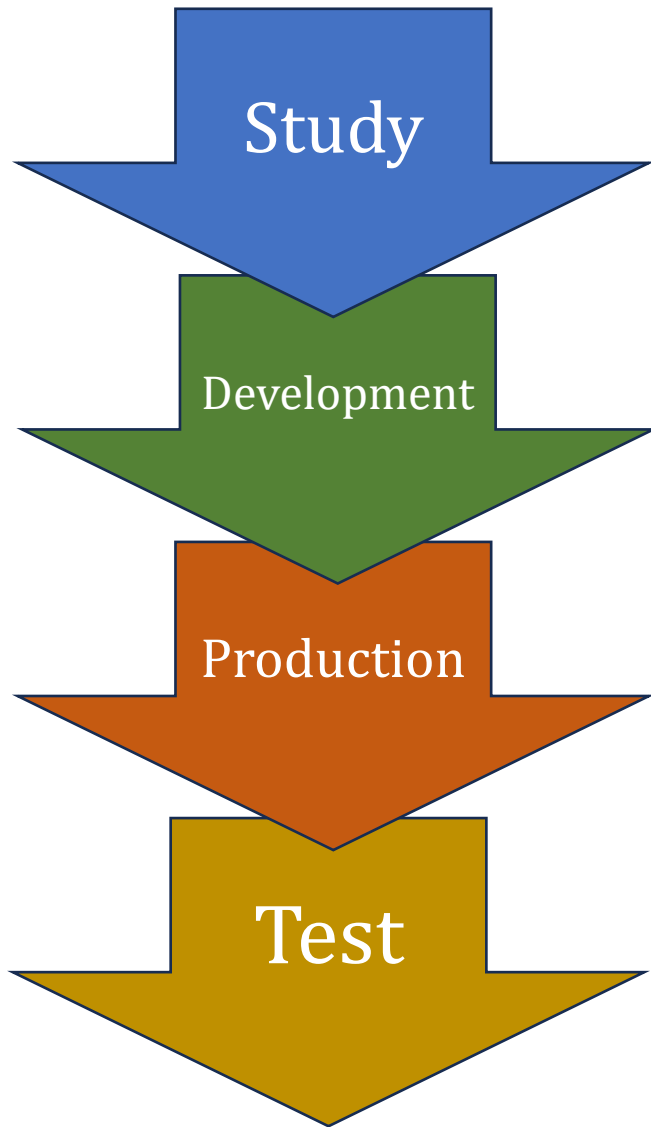

- Study **gas gain optimization** with **different geometries of the amplification stage** (pitch well, external/internal well diameters) with 100x100 mm² prototypes. [*]
- With a reduction of the well pitch from 140 μm to 90 μm, a possible **increase of the gas gain of about 2** is foreseen.

Development of a **new ASIC** based on the knowledge acquired with TIGER

n°2 500x500 mm² prototypes (second half of 2024): the choice of 2D layout will be based on the results obtained in the previous test

- Equip a μ-Rwell chamber with TIGER.
- Beam test at CERN on **40x5 mm²** prototype with **TIGER readout**.
- Test at LNF with X-ray and cosmics (with tracking system).

[*] These studies have been performed with GEM detector but never with μ-Rwell.

The End

References

- G.Bencivenni et al., *The micro-Resistive WELL detector: a compact spark-protected single amplification-stage MPGD*, 2015 JINST **10** P02008
- G.Bencivenni et al., *The μ -RWEL detector*, 2017 JINST **12** C06027
- G.Bencivenni et al., *Performance of μ -RWELL detector vs resistivity of the resistive stage*, Nucl. Instrum.Meth. **A 886**(2018)36.
- G.Bencivenni et al., *The μ -RWELL layouts for high particle rate*, 2019 JINST **14** P05014
- G.Bencivenni et al., *On the space resolution of the μ -RWELL*, 2020 JINST **16** P08036
- A.Ochietal., *Carbon sputtering Technology for MPDG detectors*, PoS(TIPP2014)351 (2014).

Backup slides

IDEA geometry

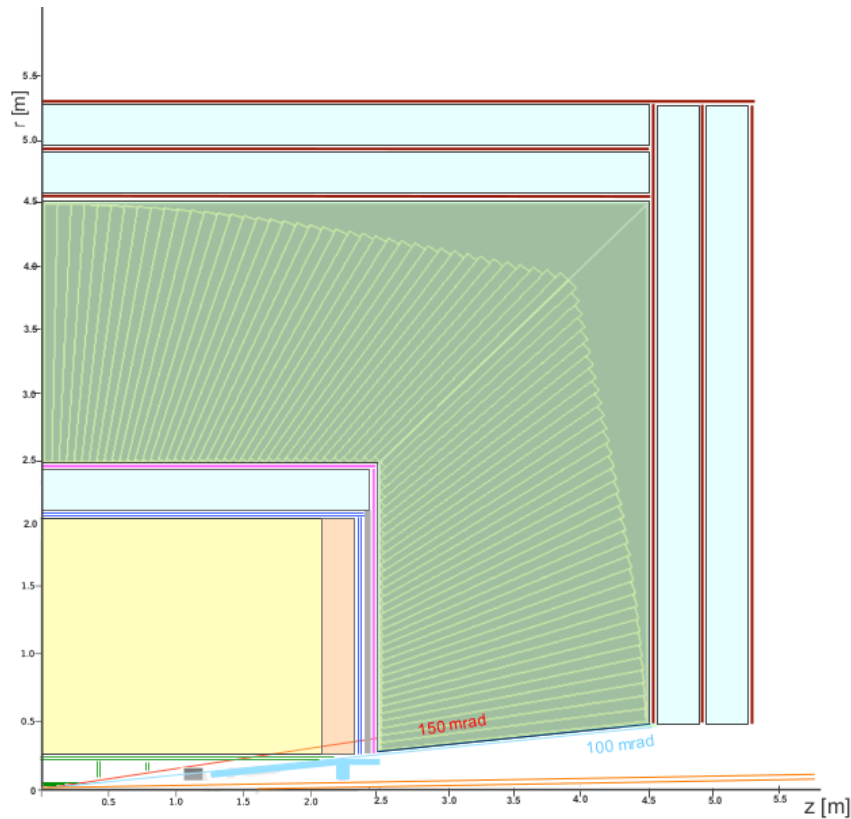

LEGENDA

- drift chamber
- drift chamber service area
- magnet and iron return yoke
- calorimeter
- Si pixels
 20 μ m \times 20 μ m (inner barrel layers)
 50 μ m \times 1mm (outer barrel layers)
 50 μ m \times 50 μ m (forward disks)
- Si strips double stereo layer 50 μ m \times 10cm
- μ Rwell double layer 0.4mm \times 50cm
- μ Rwell double layer 1.5mm \times 50cm
- absorber (lead)
- luminometer
- steel simulating compensating and shielding solenoids
- vacuum tube

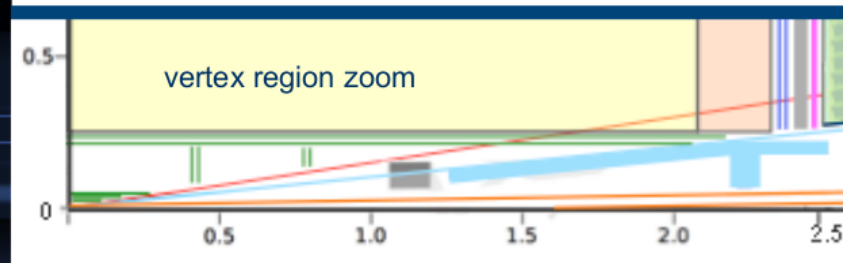

IDEA's Muon System

Starting from a simple cylindrical shape for both Muon System and Preshower, it is possible to simulate different layouts for the detectors.

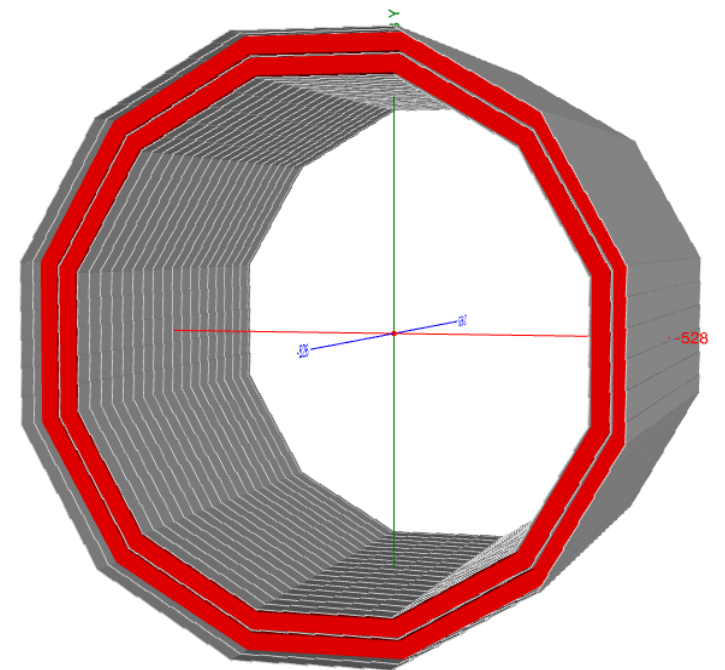
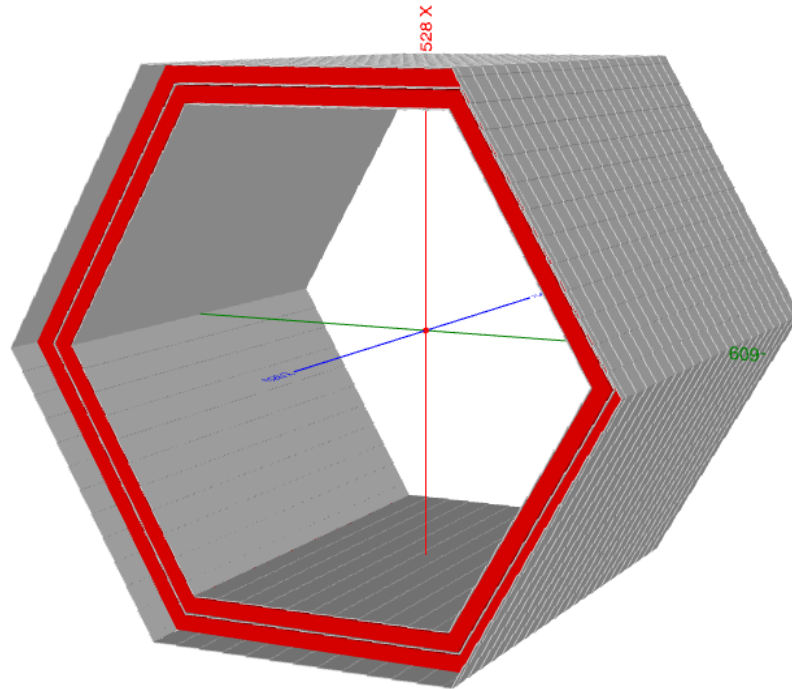
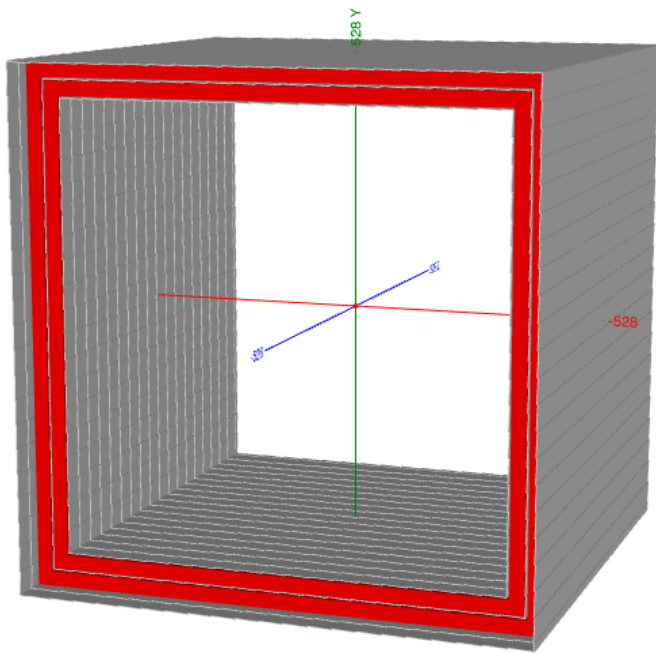

Charge collection and multiplication

- The “WELL” acts as a multiplication channel for the ionization produced in the gas of the drift gap
- The **charge induced** on the resistive layer is **spread with a time constant**

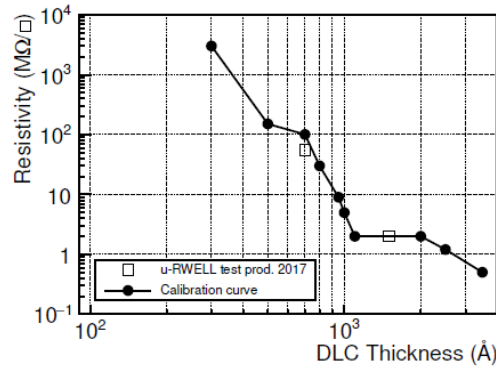

$$\tau \sim \rho \times C$$

$$C = \epsilon_0 \times \epsilon_r \times \frac{S}{t} \cong 50 \text{ pF/m}$$

(pitch width 0,4 mm)

Charge collected by the APV25 on the strip readout (resistivity $\sim 10 \text{ M}\Omega/\square$)

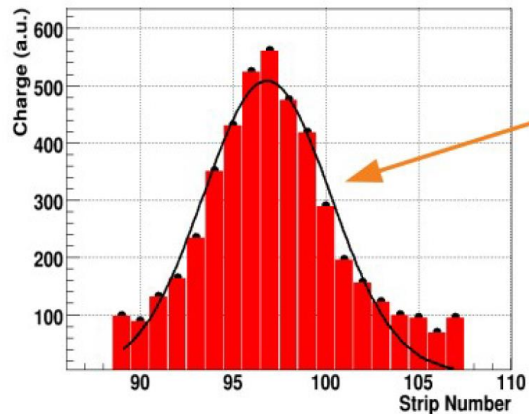

APV25 and 400 μm strip pitch: capacity = 15 pF

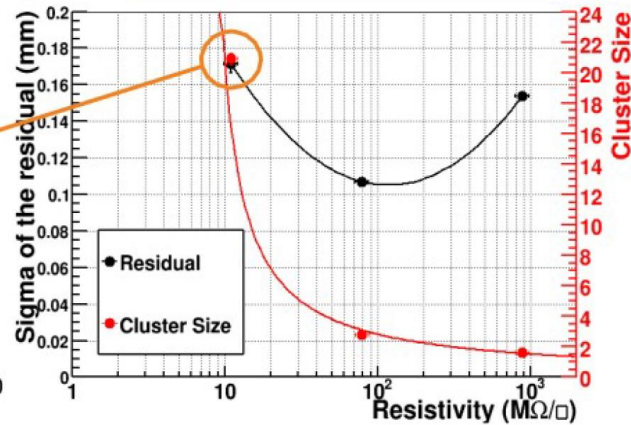

G. Bencivenni et al., NIM A 886 (2018) 36

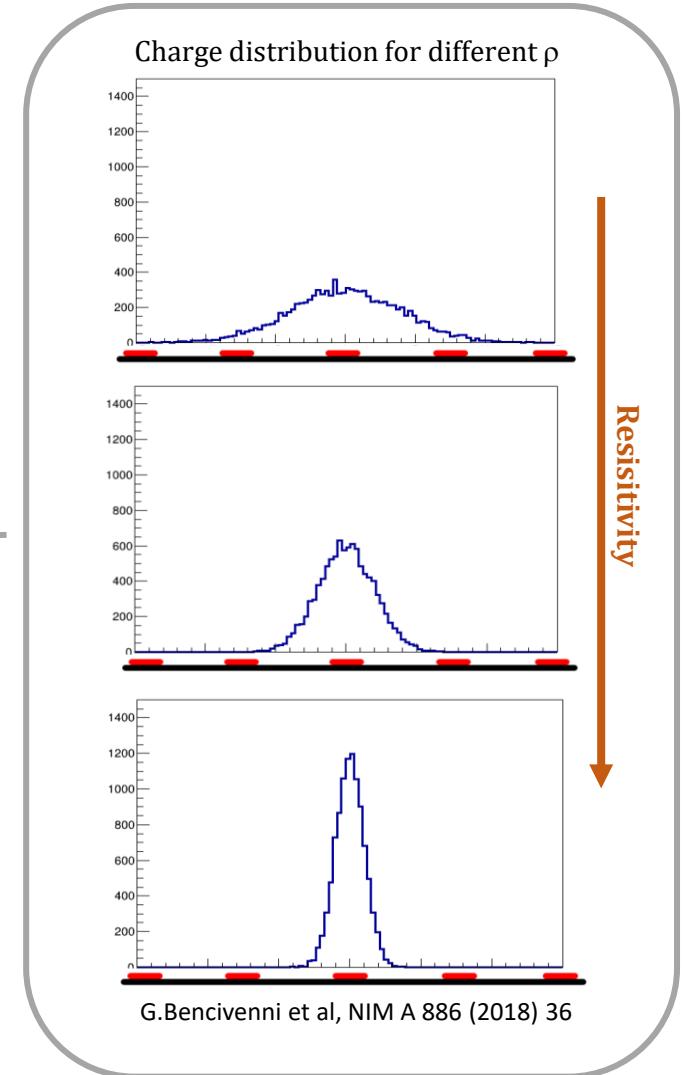

Capacitive Sharing readout: Principle & Motivation (K.GNAVO)

- Vertical stack of pad layers: charge transfer via capacitive coupling
- Pads have dedicated position from one layer to the layer underneath
- Doubling in size at each layer
- Transverse sharing of the charges between neighbouring pads of layer $(i+1)$ from vertical charge transfer from layer (i)
- The scheme preserves spatial information *i.e.* the spatial resolution obtained with the largest readout strips or pads.
 ⇒ **Goal: 50 μm for 1 mm strip r/o**
 150 μm for 1 cm^2 pad r/o
- Proof of concept established with 800 μm X-Y strips

AIM:

- Develop high performance and low channel count readout structures for MPGDs
- Reduce the number of readout electronic channels for large area MPGDs
- Low-cost technology for large area and standard PCB fabrication techniques

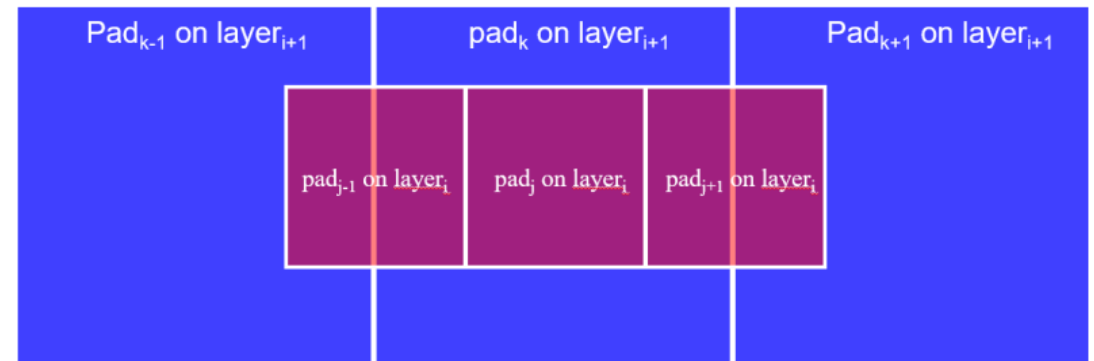
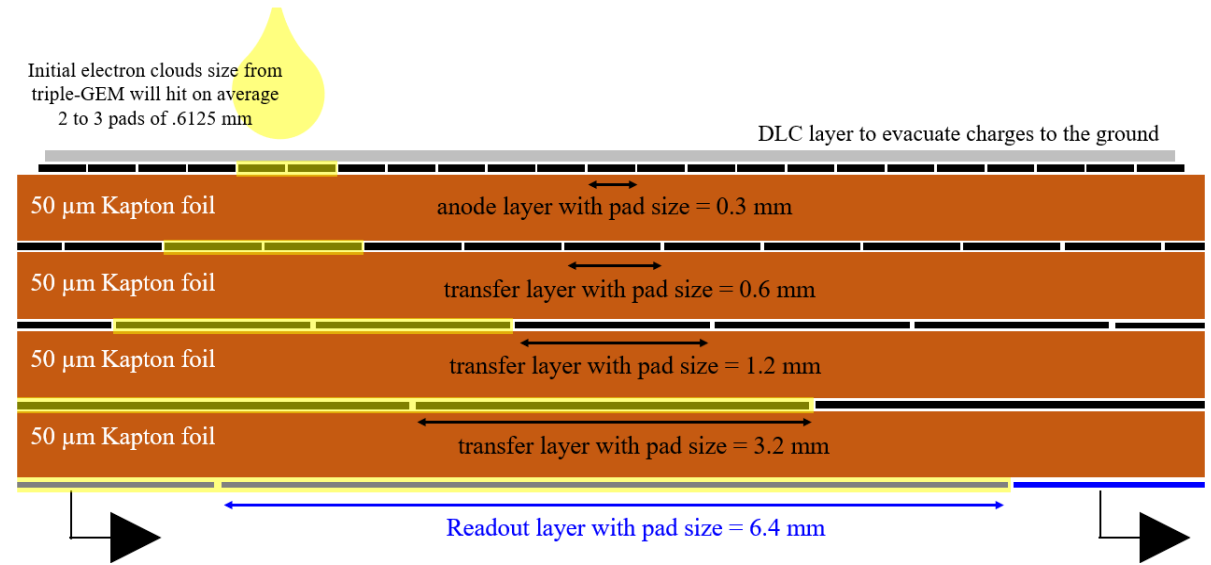

Capacitive Sharing readout: Principle & Motivation (K.GNAVO)

- Vertical stack of pad layers: charge transfer via capacitive coupling
- Pads have dedicated position from one layer to the layer underneath
- Doubling in size at each layer
- Transverse sharing of the charges between neighbouring pads of layer ($i+1$) from vertical charge transfer from layer (i)
- The scheme preserves spatial information *i.e.* the spatial resolution obtained with the largest readout strips or pads.
⇒ Goal: 50 μm for 1 mm strip r/o
150 μm for 1 cm^2 pad r/o
- Proof of concept established with 800 μm X-Y strips

AIM:

- Develop high performance and low channel count readout structures for MPGDs
- Reduce the number of readout electronic channels for large area MPGDs
- Low-cost technology for large area and standard PCB fabrication techniques

