

# Deeply Virtual Compton Scattering (DVCS) with CLAS & CLAS12

## Unraveling Confinement Forces in the Proton

Latifa Elouadrhiri

*Thomas Jefferson National Accelerator Facility*

N &  $N^*$  Structure with Hard Exclusive Processes  
IPN Orsay, 29 - 30 May 2017

# Introduction

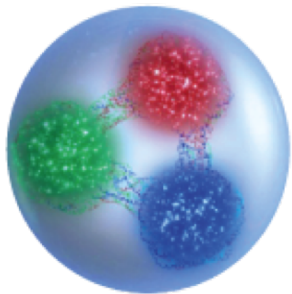

**QCD** Mystery: Color confinement & its origin?

*"Paradox 1: Quarks are Born Free but Everywhere they are in Chains"(\*)*.

No quark is ever found alone. How do strong forces balance to produce stability?

**The understanding of color confinement is central to hadron and particle physics.**

(\*) F-Wilczek, Lecture given in acceptance of the Nobel Prize, Dec 2004

# DVCS Science Program with CLAS & CLAS12

Make inroads towards understanding the 3D imaging of the nucleon structure and the confinement of light quarks, gluons and their role in providing dynamical stability of the nucleon This became possible:

1. **Breakthrough in theory of QCD (1990s):** developing **DVCS** as a tool to characterize the structure of the nucleon within QCD and showing how its properties can be probed through experiments.

*(D. Mueller (1994), X.Ji (1996), A.Radyushkin (1996))*

*(2015 JSA Prize award to X. Ji and A. Radyushkin & 2016 APS Feshbach Prize award to X. Ji )*

2. **Construction of state of the art experimental apparatus:**
  - ▶ Jefferson Lab 12 GeV upgrade
  - ▶ Large Acceptance Spectrometer (CLAS12)
  - ▶ High luminosity
  - ▶ High resolution

# Generalized Parton Distributions (GPDs)

$$F_{\mathcal{O}}^q(x, \xi, t) = \int \frac{dz^-}{2\pi} e^{ixP^+z^-} \langle P_2 | \bar{q}(-z) \mathcal{O} q(z) | P_1 \rangle \Big|_{z^+=0, \mathbf{z}=0}$$

List of GPDs & their corresponding operators

	GPDs $F_{\mathcal{O}}$	operator $\mathcal{O}$	type	reaction
Chiral even	$H, E$ $\tilde{H}, \tilde{E}$	$\gamma^\mu, \Delta_\nu \sigma^{\mu\nu}$ $\gamma^\mu \gamma_5, \Delta^\mu \gamma_5$	vector, tensor axial-vector, pseudoscalar	$\gamma^*(Q^2) + N \rightarrow \gamma + N$

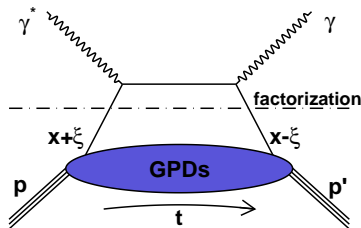

- ▶  $Q^2 = -q^2 = -(k - k')^2$
- ▶  $x_B = \frac{Q^2}{2p \cdot q}$
- ▶  $x$  longitudinal momentum fraction carried by the active quark
- ▶  $\xi \sim \frac{x_B}{2-x_B}$  the longitudinal momentum transfer
- ▶  $t = (p - p')^2$  squared momentum transfer to the nucleon

# Physics Content of GPDs

- ▶ At  $\xi = 0, t = 0$  the GPDs reduce to ordinary PDFs
- ▶ The integrals of  $H$  and  $E$  over  $x$  are independent of  $\xi$  and reduces to elastic FFs
- ▶ **What other physics content can be extracted from GPDs?**

# Nucleon Energy Momentum Tensor Form Factors

$$\langle P_2 | T^{\mu\nu} | P_1 \rangle = \bar{u}(P_2) \left[ \frac{1}{2} M_2(t) \gamma^{(\mu} P^{\nu)} + [2J(t) - M_2(t)] P^{(\mu} i\sigma^{\nu)\lambda} \frac{\Delta_\lambda}{4M} + \frac{d_1(t)}{5M} (\Delta^\mu \Delta^\nu - \Delta^2 g^{\mu\nu}) \right] u$$

The Energy Momentum Tensor couples directly to Gravitons

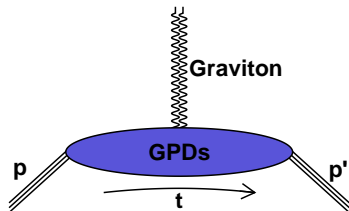

...but we do not have beams of gravitons ☹️

# Nucleon Energy Momentum Tensor Form Factors

$$\langle P_2 | T^{\mu\nu} | P_1 \rangle = \bar{u}(P_2) \left[ \frac{1}{2} M_2(t) \gamma^{(\mu} P^{\nu)} + [2J(t) - M_2(t)] P^{(\mu} i\sigma^{\nu)\lambda} \frac{\Delta_\lambda}{4M} + \frac{d_1(t)}{5M} (\Delta^\mu \Delta^\nu - \Delta^2 g^{\mu\nu}) \right] u(P_1)$$

The Energy Momentum Tensor couples directly to Gravitons

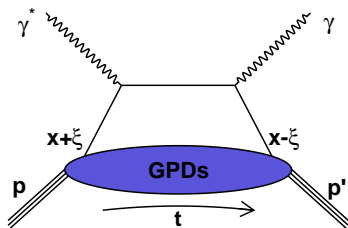

The Form Factors of the Energy Momentum Tensor also appear as the second Mellin moment of the GPDs :

$$\int dx x [H(x, \xi, t) + E(x, \xi, t)] = 2J(t)$$

$$\int dx x H(x, \xi, t) = M_2(t) + \frac{4}{5} \xi^2 d_1(t)$$

→ QCD link between experiment and gravitational degrees of freedom!

- ▶  $J$  encodes information on the distribution of angular momentum
- ▶  $M_2$  corresponds to the distribution of mass
- ▶  $d_1$  is a fundamental characteristic of the nucleon and it is the least known!

# Distribution of Forces on Partons

The spatial part of the Energy Momentum Tensor can be parameterized to connect with the distributions of Pressure  $p(r)$  and Shear forces  $s(r)$  :

$$T_{ij}(\mathbf{r}) = s(r) \left( \frac{r_i r_j}{r^2} - \frac{1}{3} \delta_{ij} \right) + p(r) \delta_{ij}$$

The Form Factor  $d_1$  is related to them via the spherical Bessel integrals :

$$d_1(t) = 5M_N \int d^3\mathbf{r} \frac{j_2(r\sqrt{-t})}{t} s(r) = 15M_N \int d^3\mathbf{r} \frac{j_0(r\sqrt{-t})}{2t} p(r)$$

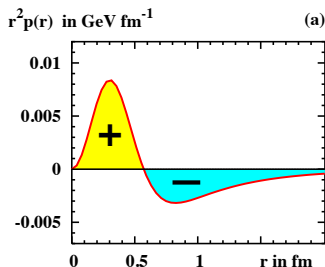

M.V. Polyakov and C. Weiss Phys. Rev. **D60**, 1999  
 P. Schweitzer *et al.*, Nucleon form-factors  
 of the energy momentum tensor in the chiral quark-soliton model  
 Phys. Rev. **D75** : 094021 , 2007

$d_1$  can be accessed as the first component of the D-term expansion in Gegenbauer polynomials :

$$D(z) = (1 - z^2) \left[ d_1 C_1^{3/2}(z) + d_3 C_3^{3/2}(z) + \dots \right]$$



# Generalized Parton Distributions and DVCS

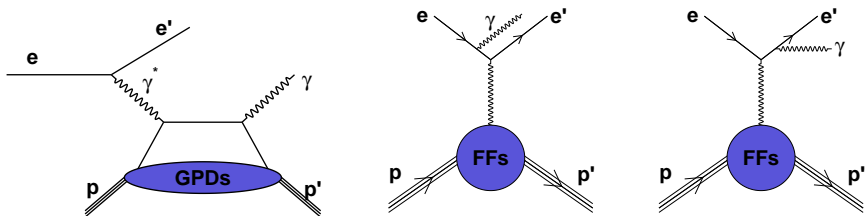

The Bethe-Heitler and DVCS processes interfere at the amplitude level :

$$|\mathcal{T}_{\text{BH}} + \mathcal{T}_{\text{DVCS}}|^2 = |\mathcal{T}_{\text{BH}}|^2 + |\mathcal{T}_{\text{DVCS}}|^2 + \mathcal{I}$$

The GPDs enter the DVCS amplitude through a complex integral. This integral is called a *Compton form factor* (CFF).

$$\mathcal{H}(\xi, t) = \int_{-1}^1 H(x, \xi, t) \left( \frac{1}{\xi - x - i\epsilon} - \frac{1}{\xi + x - i\epsilon} \right) dx$$

# DVCS Physics

In the context of DVCS, different beam energies allow the separation of the interference and square terms :

$$\mathcal{I} \sim 1/y^3 \quad , \quad |\mathcal{T}^{\text{DVCS}}|^2 \sim 1/y^2, \quad y = \frac{E_{\text{beam}} - E_{\text{electron}}}{E_{\text{beam}}}$$

The coefficients of the  $\phi$  harmonic decomposition of the cross-sections are related to the GPDs *via* the Compton Form Factors :

$$\mathcal{H}(\xi, t) = i\pi[H(\xi, \xi, t) - H(-\xi, \xi, t)] + \mathcal{P} \int_{-1}^1 dx \left[ \frac{1}{\xi - x} - \frac{1}{\xi + x} \right] H(x, \xi, t)$$

The Real and Imaginary parts of the CFFs are related through Dispersion Relations allowing access to the **D** term :

$$\mathcal{P} \int_{-1}^1 dx \left[ \frac{1}{\xi - x} - \frac{1}{\xi + x} \right] H(x, \xi, t) \\ \stackrel{\text{LO}}{=} D(t) + \mathcal{P} \int_{-1}^1 dx \left( \frac{1}{\xi - x} - \frac{1}{\xi + x} \right) [H(x, x, t) - H(-x, x, t)]$$

# Experimental Technique

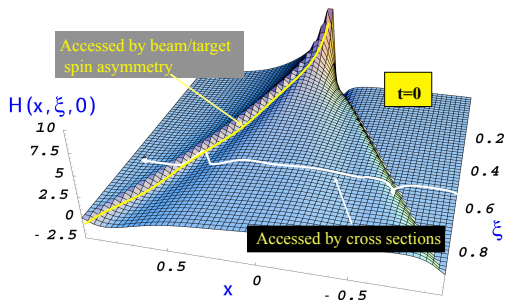

- ▶ Measure the DVCS cross section that gives access to the  $DVCS^2$  and real part of the CCFs
- ▶ Measure the DVCS-BH beam spin asymmetry that gives access to the imaginary part of the CCFs
- ▶ Measurement at different beam energies allows the separation of the three contributing terms

# Experimental Configuration

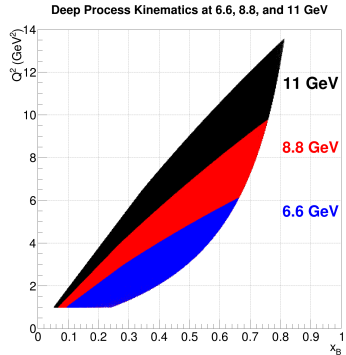
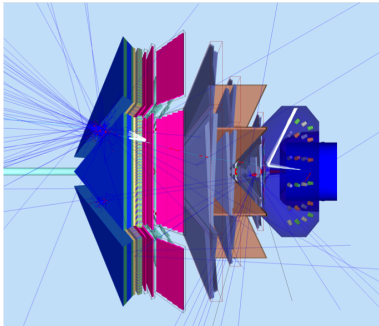

- ▶  $\mathcal{L} = 1 \times 10^{35} \text{ cm}^{-2}\text{s}^{-1}$
- ▶ Inclusive electron trigger (all calibration reactions will be analyzed in parallel)
- ▶ Electrons in the forward detector
- ▶ Protons in the central detector and forward detector
- ▶ Photons in the forward detector and forward tagger

# Kinematical Coverage, Exclusivity

Beam energy 11 GeV

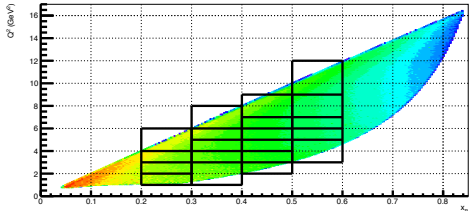

Cone Angle

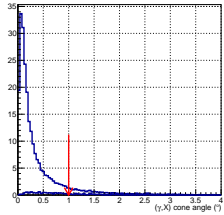

Missing Energy

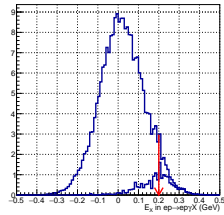

- ▶ Black boxes example of binning in the  $(x_B, Q^2)$  plane
- ▶  $\pi^0$  decay with one photon lost contamination to the DVCS sample
- ▶ Contamination kept at levels between 5% and 10%
- ▶ Cone angle : between the detected and predicted photon
- ▶ Missing mass  $ep \rightarrow e\gamma Y$

# Kinematical Coverage

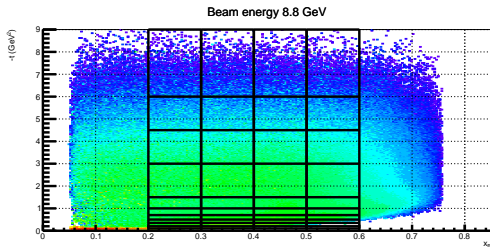
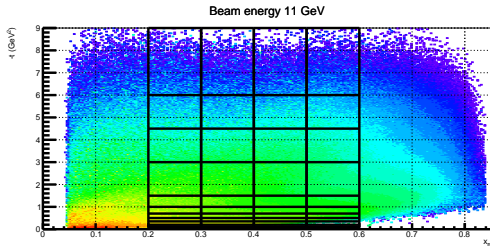

# DVCS Projected Cross Section at 11GeV & 8.8GeV

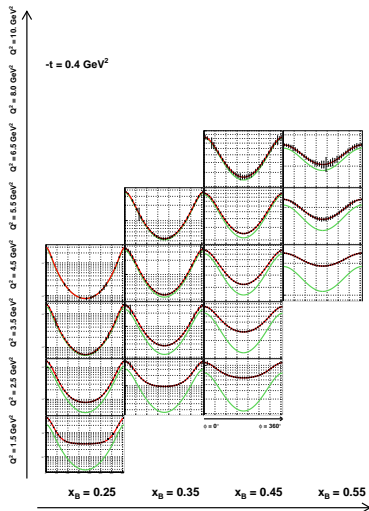
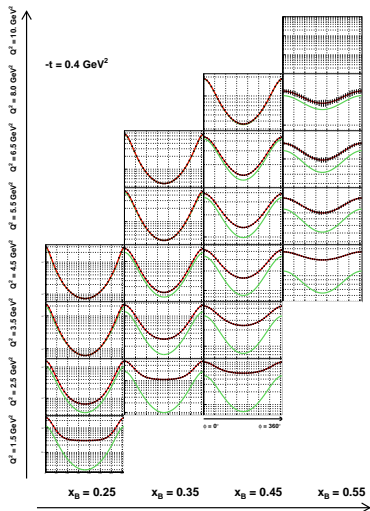

# DVCS Projected Results

$x_B=0.35, Q^2=2.21, -t=0.42, E=6.6$

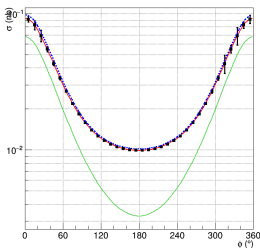

$x_B=0.35, Q^2=2.21, -t=0.42, E=6.6$

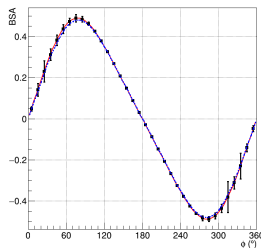

$x_B=0.35, Q^2=2.22, -t=0.41, E=8.8$

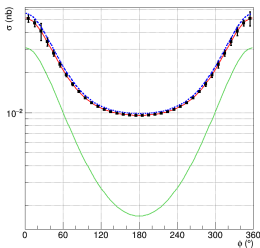

$x_B=0.35, Q^2=2.22, -t=0.41, E=8.8$

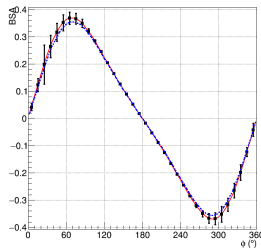

- ▶ Left : cross-sections at fixed kinematics for beam energies 6.6 GeV and 8.8 GeV
- ▶ Right : corresponding Beam Spin Asymmetries
- ▶ Green : pure Bethe-Heitler
- ▶ Red : model fit on 6 GeV data
- ▶ Blue : simultaneous fit of the projected data
- ▶ Separation of :  
 $\mathcal{I} \sim 1/y^3$  and  $|\mathcal{T}^{\text{DVCS}}|^2 \sim 1/y^2$



## Systematic Errors

Anticipated systematic uncertainties based on our previous experience from the CLAS experiment analysis at 6 GeV and the CLAS12 design parameters

Source	Error Estimation
Acceptance	2.5 %
Target Thickness	0.2 %
Beam Charge	0.2 %
PID	1.0 %
Monte Carlo Generator	0.5 %
Radiative Corrections	1.0 %
$\pi^0$ Contamination	1.0%
Energy Dependence Extraction	9%

# Separated CFF

### Rosenbluth separated ImH

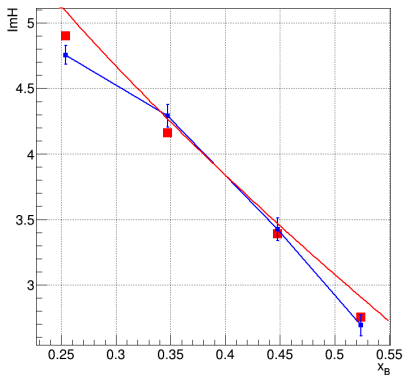

### Rosenbluth separated ReH

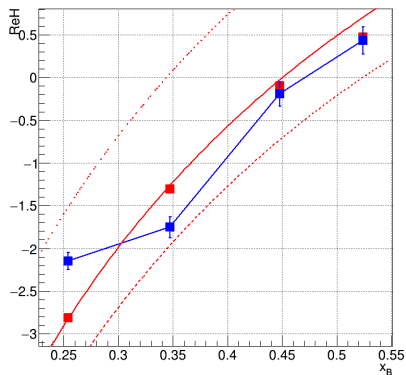

- ▶ Left : result for the extracted Imaginary part of  $\mathcal{H}$
- ▶ Right : result for the extracted Real part of  $\mathcal{H}$
- ▶ Three red curves correspond to three scenarios for the D-term

# Model Extraction of the Pressure Forces

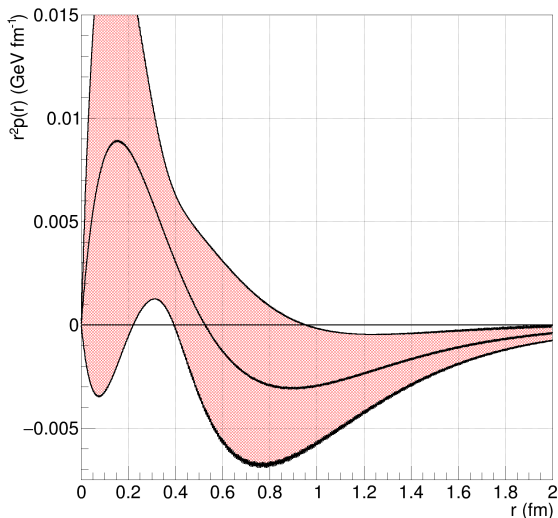

Use a dipole parametrization for  $d_1(t)$  in

$$d_1(t) = 15M_N \int d^3\mathbf{r} \frac{j_0(r\sqrt{-t})}{2t} p(r)$$

Model parameters extracted from **world data**

# Model Extraction of the Pressure Forces

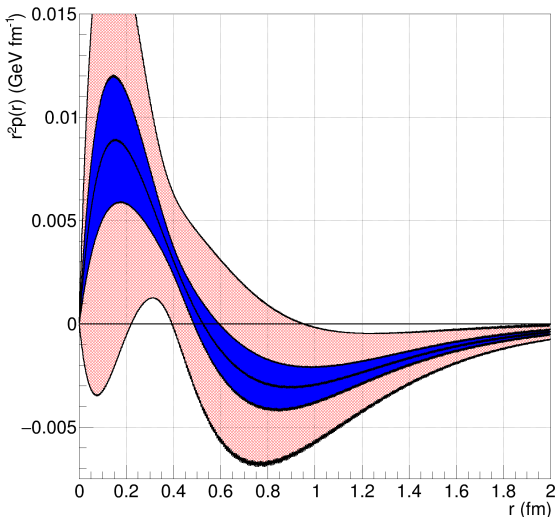

Use a dipole parametrization for  $d_1(t)$  in

$$d_1(t) = 15M_N \int d^3\mathbf{r} \frac{j_0(r\sqrt{-t})}{2t} p(r)$$

Model parameters extracted from projected results from the proposed experiment with CLAS12

# Future Measurements, GPD extractions & and Nucleon 3D Imaging

# CLAS12 GPD program

Number	Title	Contact	Days	Energy	Target
E12-06-108	Hard Exclusive Electroproduction of $\pi^0$ and $\eta$	Stoler	80	11	IH <sub>2</sub>
E12-06-119	Deeply Virtual Compton Scattering	Sabatie	80	11	IH <sub>2</sub>
E12-12-001	Timelike Compton Scat. & $J/\Psi$ prod. in $e^+e^-$	Nadel-Turonski	120	11	IH <sub>2</sub>
E12-12-007	Exclusive $\phi$ meson electroproduction	Stoler	60	11	IH <sub>2</sub>
E12-11-003	DVCS on Neutron Target	Niccolai	90	11	ID <sub>2</sub>
E12-06-119	Deeply Virtual Compton Scattering	Sabatie	120	11	NH <sub>3</sub>
C12-12-010	DVCS with a transverse target	Elouadrhiri	110	11	HD-ice
E12-16-010	DVCS with CLAS12 at 6.6 GeV and 8.8 GeV	Elouadrhiri	50+50	6.6 & 8.8	IH <sub>2</sub>

# Proton BSA DVCS $A_{LU}$

E12-06-009

80 days @  $\mathcal{L} = 10^{35} \text{ cm}^{-2} \text{ s}^{-1}$  with 85% polarized beam

$$A_{LU} \propto F_1 \mathcal{H} + \xi G_M \tilde{\mathcal{H}} - \frac{t}{4M^2} F_2 \mathcal{E}$$

$$A = (\sigma^+ - \sigma^-) / (\sigma^+ + \sigma^-)$$

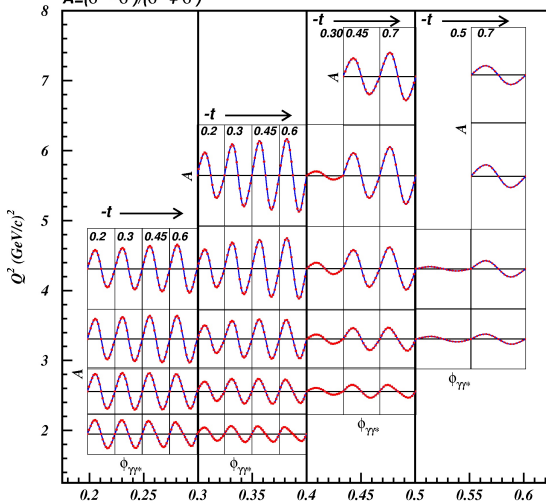

Beam Spin Asymmetries  
 $\phi$  dependence

Statistical uncertainties :  
from 1 % (low  $Q^2$ )  
to 10 % (high  $Q^2$ )

Unprecedented statistics  
over the full  $\phi$  range  
up to high  $x = 0.6$

Proton BSA DVCS  $A_{LU}$ 

E12-06-009

80 days @  $\mathcal{L} = 10^{35} \text{ cm}^{-2} \text{ s}^{-1}$  with 85% polarized beam

$$A_{LU} \propto F_1 \mathcal{H} + \xi G_M \tilde{\mathcal{H}} - \frac{t}{4M^2} F_2 \mathcal{E}$$

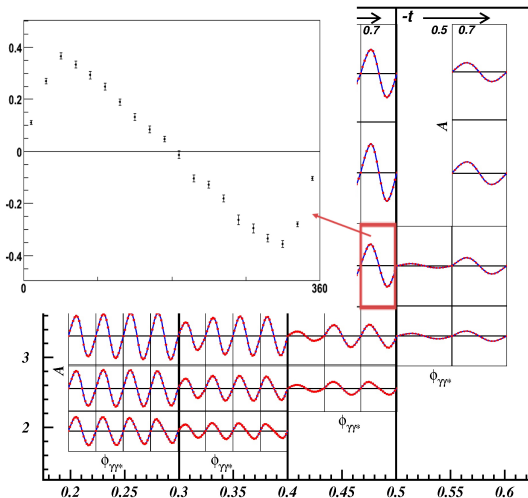

Beam Spin Asymmetries  
 $\phi$  dependence

Statistical uncertainties :  
from 1 % (low  $Q^2$ )  
to 10 % (high  $Q^2$ )

Unprecedented statistics  
over the full  $\phi$  range  
up to high  $x = 0.6$



Proton DVCS TSA  $A_{UL}$ 

E12-06-009

120 days @  $\mathcal{L} = 2 \times 10^{35} \text{ cm}^{-2} \text{ s}^{-1}$  with 80% polarized  $\text{NH}_3$ 

$$A_{UL} \propto F_1 \tilde{\mathcal{H}} + \xi G_M \left( \mathcal{H} + \frac{\xi}{1+\xi} \mathcal{E} \right) - \dots$$

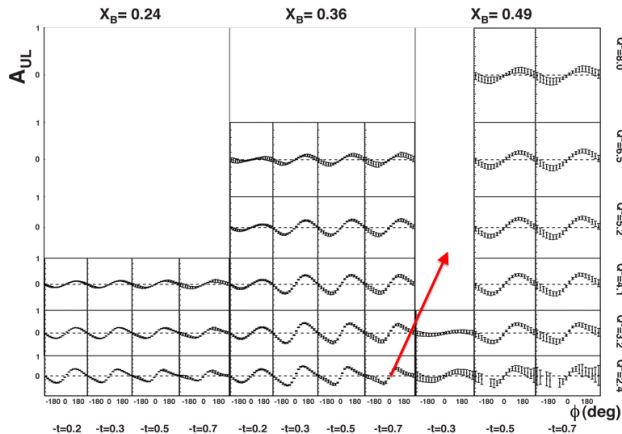

Target Spin Asymmetries  
 $\phi$  dependence

Statistical uncertainties :  
from 2 % (low  $Q^2$ )  
to 30 % (high  $Q^2$ )

Unprecedented statistics  
over the full  $\phi$  range  
up to high  $x = 0.6$

Proton DVCS TSA  $A_{UL}$ 

E12-06-009

120 days @  $\mathcal{L} = 2 \times 10^{35} \text{ cm}^{-2} \text{ s}^{-1}$  with 80% polarized  $\text{NH}_3$ 

$$A_{UL} \propto F_1 \tilde{\mathcal{H}} + \xi G_M \left( \mathcal{H} + \frac{\xi}{1+\xi} \mathcal{E} \right) - \dots$$

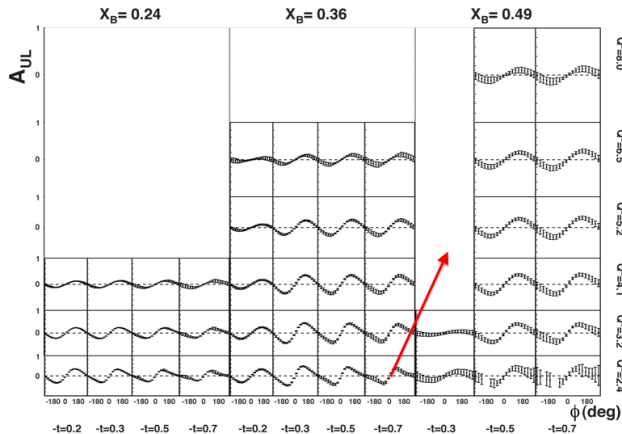

Target Spin Asymmetries  
 $\phi$  dependence

Statistical uncertainties :  
from 2 % (low  $Q^2$ )  
to 30 % (high  $Q^2$ )

Unprecedented statistics  
over the full  $\phi$  range  
up to high  $x = 0.6$

Proton DVCS TSA  $A_{UL}$ 

E12-06-009

120 days @  $\mathcal{L} = 2 \times 10^{35} \text{ cm}^{-2} \text{ s}^{-1}$  with 80% polarized  $\text{NH}_3$ 

$$A_{UL} \propto F_1 \tilde{\mathcal{H}} + \xi G_M \left( \mathcal{H} + \frac{\xi}{1+\xi} \mathcal{E} \right) - \dots$$

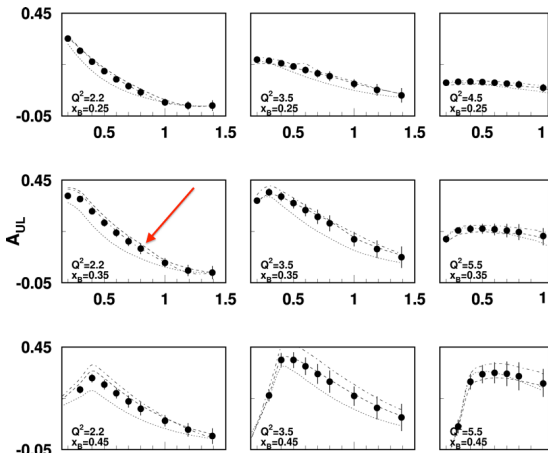
TSA  $t$ -slopesSample kinematics  
for target asymmetryChange of  $t$ -slope with  $x_B$   
 $\leftrightarrow$   
imaging  $\Delta q(x_B, b_\perp)$ 

# Projected Impact on GPD Extraction

Using simulated data based on VGG model.  
Input GPD  $H$  extracted with good accuracy

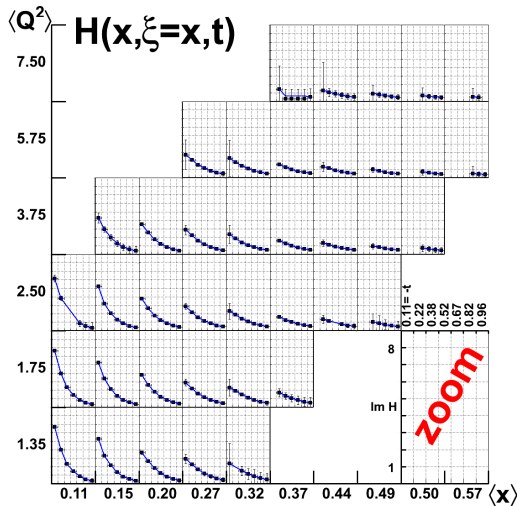

# Projected Impact on GPD Extraction

Using simulated data based on VGG model.  
Input GPD  $H$  extracted with good accuracy

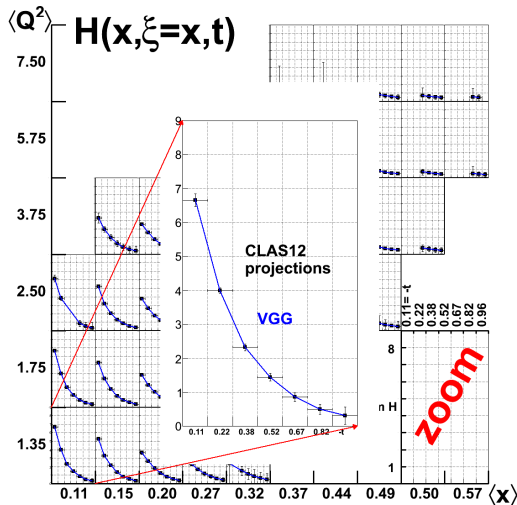

# Projected Impact on GPD Extraction

Using simulated data based on VGG model.  
Input GPD  $H$  extracted with good accuracy

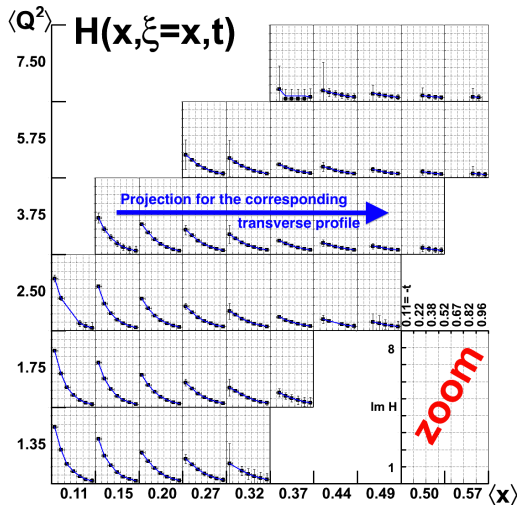

# Projection for the Nucleon transverse profile

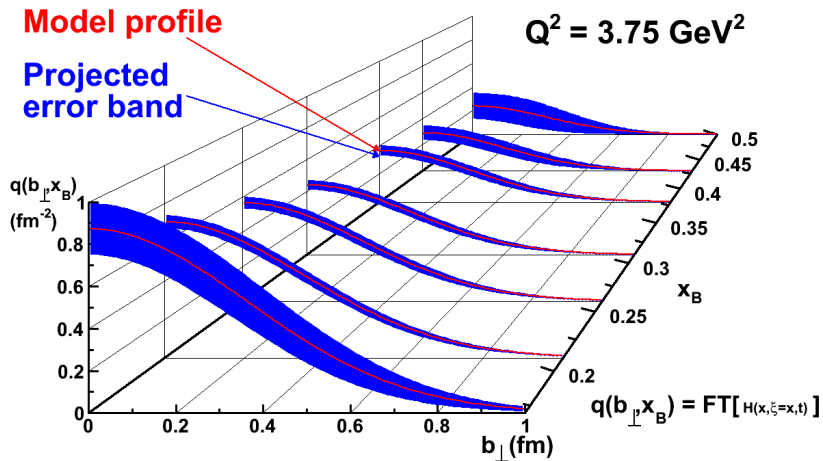

Precision tomography in the valence region

## Summary

Measurement of DVCS process with CLAS12 at 6.6 GeV, 8.8 GeV & combined with the measurement at 11GeV

- ▶ Separate the interference term  $DVCS/BH$  and  $DVCS^2$
- ▶ Separate the imaginary & real parts of the CCF of GPDs
- ▶ Measure the  $t$  dependence of D term at several values of  $x_B$
- ▶ **Access to the fundamental QCD quantities: pressure and shear force distributions of the nucleon, shed light on confinement**

The data from this experiment will allow access to the Chiral Odd GPDs via the measurement of the cross-section for exclusive  $\pi^0$

**The CLAS12 experiment is a critical component of the Jefferson Lab ( Hall A, Hall C, COMPASS & others) GPD program**



# Summary & Outlook

- ▶ First Generation Experiments Published from CLAS
- ▶ Entering the 12 GeV and High Precision era
- ▶ Transverse Imaging, Energy Momentum Tensor to shed light on confinement

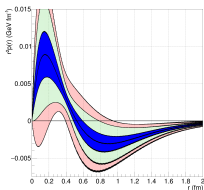
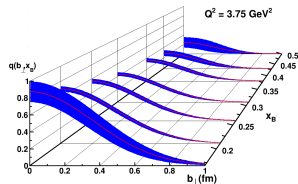
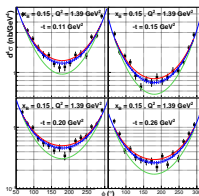

White paper in  
preparation

The poster features a background image of a sailboat on the ocean, with a 3D grid overlaying the water and sky. The text is arranged as follows:

# 3D NUCLEON TOMOGRAPHY WORKSHOP

*Modeling and Extraction Methodology*

March 15-17 • Jefferson Lab  
Newport News, Virginia

*Organizing Committee*

- Amber Boehlein (Jefferson Lab)
- Latifa Elouadrhiri (Jefferson Lab)
- David Richards (Jefferson Lab)
- Franck Sabatié (CEA/Saclay)
- Peter Schweitzer (UConn)

Jefferson Lab  
[www.jlab.org/conferences/3Dmodeling](http://www.jlab.org/conferences/3Dmodeling)

Navigation icons: list, search, refresh

# Thank You!