Monte Carlo radiation transport codes

How do they work ?

Michel Maire (Lapp/Annecy)

Outline

From simplest case to complete process :

- Decay in flight of an unstable particle
- Photon Compton scattering in matter
- Multiple Coulomb scattering of charged particle ($e^{-/+}$)
- Ionization : energy loss by charged particle

Decay in flight (1)

- An unstable particle have a time of life τ
initial momentum p (\rightarrow velocity v)
 \rightarrow distance to travel before decay $AB = d_1 = \tau v$
(non relativist)

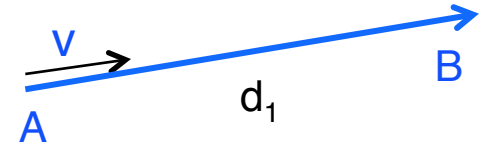

- Geometry : the particle is inside a box.
compute distance to boundary $AC = d_2$
- Transport the particle $s = \min(d_1, d_2)$
- if $C < B$: do nothing in C,
but compute the time spent in flight : $\Delta t = AC/v$
if $B < C$: decay the particle

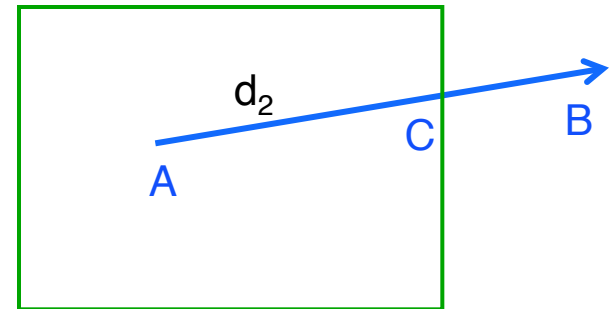

Geometry (1)

- The apparatus is described as an assembly of volumes made of homogeneous, amorphous materials
- Volumes can be embedded or assembled with boolean operations

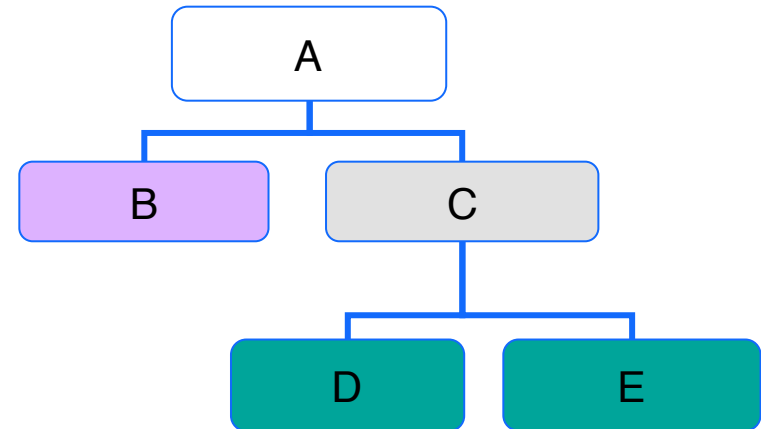
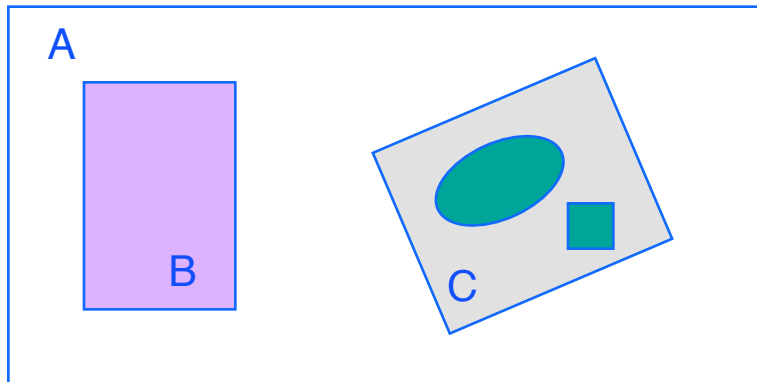

- when travelling inside the apparatus, the particle must know :
 - where I am ? → locate the current volume
 - where I am going ? → compute distance to next boundary

Geometry (2)

- remember : a computer program is blind ...

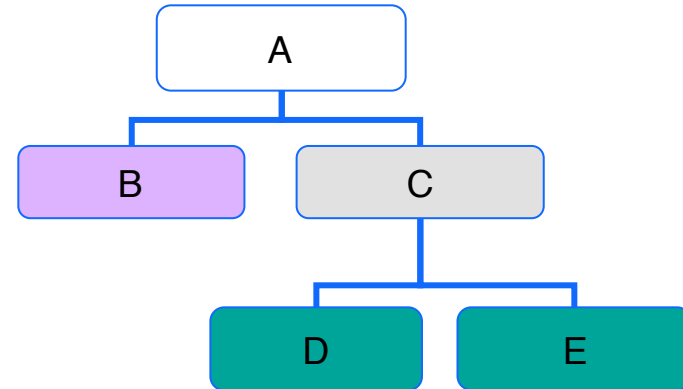
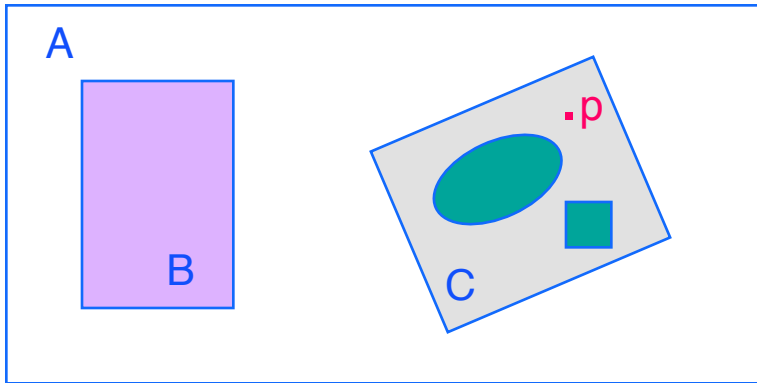

- where I am ? → locate the current volume
- where I am going ? → compute distance to next boundary

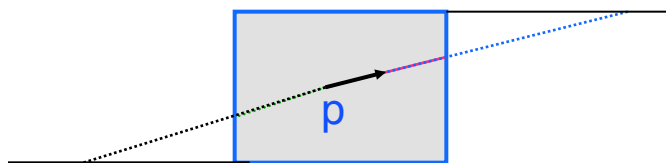

example : a point P in a box

→ compute intersections with 6 planes

Decay in flight (2)

- The time of life, t , is a random variable with probability density function :

$$f(t) = \frac{1}{\tau} \exp\left(-\frac{t}{\tau}\right) \quad t \geq 0$$

τ is the mean life of the particle

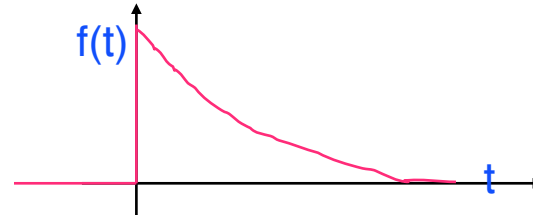

- It can be demonstrated in a general way that the cumulative distribution function is itself a random variable with uniform probability on $[0,1]$

$$r = F(t) = \int_{-\infty}^t f(u) du$$

- therefore :
- 1- choose r uniformly random on $[0,1]$
 - 2 - compute $t = F^{-1}(r)$

- For the exponential law, this gives : $t = -\tau \ln(1-r) = -\tau \ln(r')$

Decay in flight (3)

- When the particle travel on a distance d , one must update the elapsed time of life :

$$t \leftarrow (t - d/v)$$

- When $t = 0$, one must trigger the decay of the of the particle

- for instance $\pi^0 \rightarrow \gamma \gamma$ ($\sim 99\%$)
 $\rightarrow \gamma e^+ e^-$ ($\sim 1\%$)

- Select a channel according the branching ratio

\rightarrow choose r uniformly on $[0,1]$

- Generate the final state

- in the rest fram of the π^0 : $d\Omega = \sin\theta d\theta d\phi$
- apply Lorentz transform

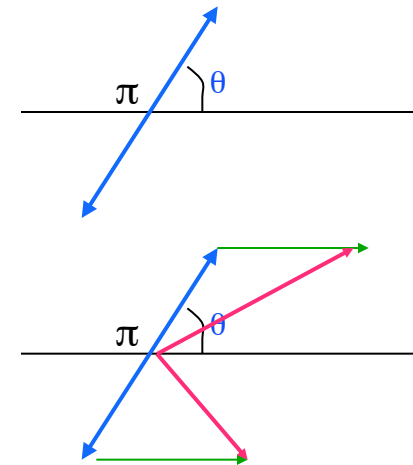
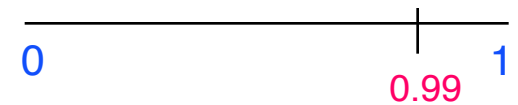
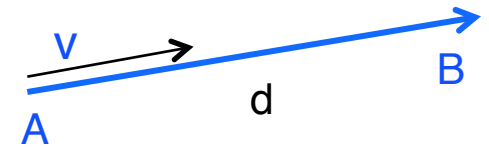

Decay in flight : comments

- the generation of the whole process needs at least 4 random numbers
- the decay is the simplest but general scheme of the so called **analogue Monte Carlo** transport simulation
- comparison with geometry and particle transport : what is really needed is **step length**, not directly time of life

Compton scattering (1)



The distance before interaction, L , is a random variable

cross section per atom : $\sigma(E, z)$

nb of atoms per volume : $n_{\text{at}} = \frac{\rho N}{A}$

cross section per volume : $\eta(E, \rho) = n_{\text{at}} \sigma$ (η is in $1/\text{cm}$)

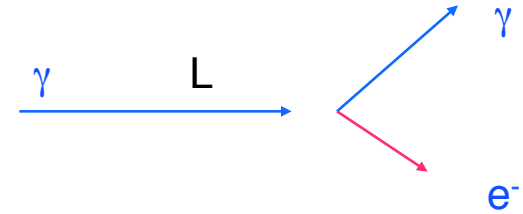

- $\eta(E, \rho)$ is the probability of Compton interaction per cm
- $\lambda(E, \rho) = \eta^{-1}$ is the mean free path associated to the process (Compton)

The probability distribution of L : $f(l) = \eta \exp(-\eta l) = \frac{1}{\lambda} \exp\left(-\frac{l}{\lambda}\right)$

→ Sample $l = -\lambda \ln(r)$ with r uniform in $[0, 1]$

Compton scattering (2)

- $\lambda(E, \rho)$, and l , are dependent of the material
- one define the number of mean free path :

$$n_\lambda = \frac{l_1}{\lambda_1} + \frac{l_2}{\lambda_2} + \frac{l_3}{\lambda_3} = \int_0^{end} \frac{dl}{\lambda(l)}$$

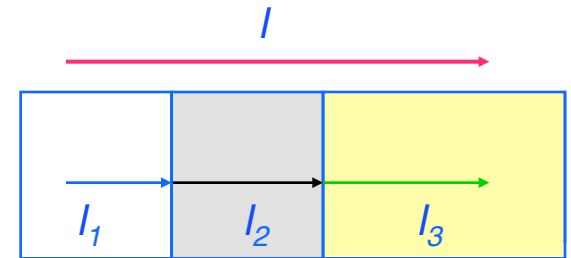

- n_λ is independent of the material and is a random variable with distribution : $f(n_\lambda) = \exp(-n_\lambda)$
 - sample n_λ at origin of the track : $n_\lambda = -\ln(r)$
 - update elapsed n_λ along the track : $n_\lambda \leftarrow (n_\lambda - dl_i / l_i)$
 - generate Compton scattering when $n_\lambda = 0$

Compton scattering (3)

- Let define :
 - energy of the scattered photon : $\varepsilon = \frac{E}{E_0}$
 - kinetic energy of scattered e^- : $t = \frac{T}{E_0} = 1 - \varepsilon$
 - angle of scattered photon : $\sin^2\left(\frac{\theta}{2}\right) = \frac{mc^2}{2E_0} \left[\frac{1}{\varepsilon} - 1 \right]$
 - \rightarrow then $\varepsilon \in [\varepsilon_0, 1]$ with $\varepsilon_0 = \frac{mc^2}{mc^2 + 2E_0}$

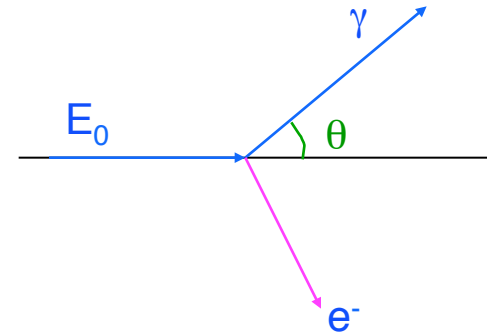

- the differential cross section is : $\frac{d\sigma}{d\varepsilon} = \frac{K}{E_0^2} \left[\frac{1}{\varepsilon} + \varepsilon \right] \left[1 - \frac{\varepsilon \sin^2(\theta/2)}{1 + \varepsilon^2} \right] = \frac{K}{E_0^2} d(\varepsilon)w(\varepsilon)$

- sample ε with the 'acceptation-rejection' method

\rightarrow remark : the generation of the whole Compton scattering process needs at least 5 random numbers

MC : acceptance-rejection method (1)

- let $f(x)$ a probability distribution.
 S_1 the surface under f
 - assume we can enclose $f(x)$ in a box ABCD, of surface S_0
 - choose a point $P(x_1, y_1)$ uniformly random within S_0
 - accept P only if P belong to S_1
- x will be sample according to the probability distribution f
- the envelope can be a distribution function $e(x)$ simple enough to be sampled with inversion technique
 - In this case x is sampled with $e(x)$ and rejected with $f(x)$

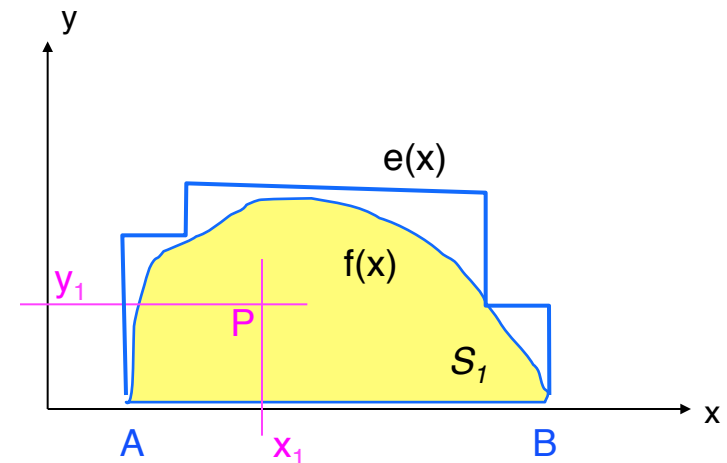
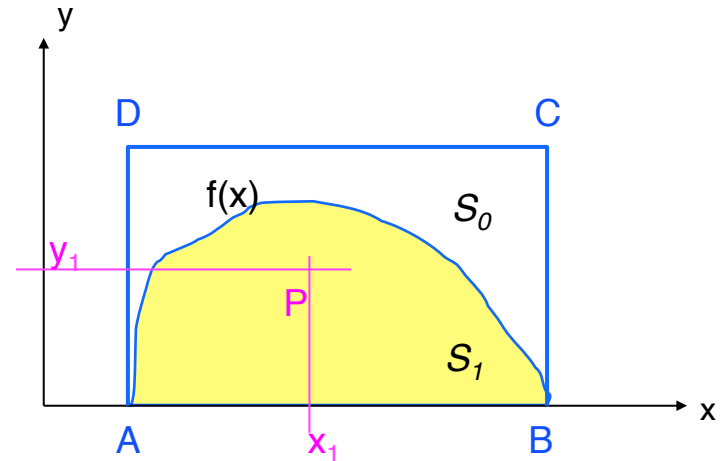

Detailed (analogue) simulation

- All interaction events are simulated in chronological succession:

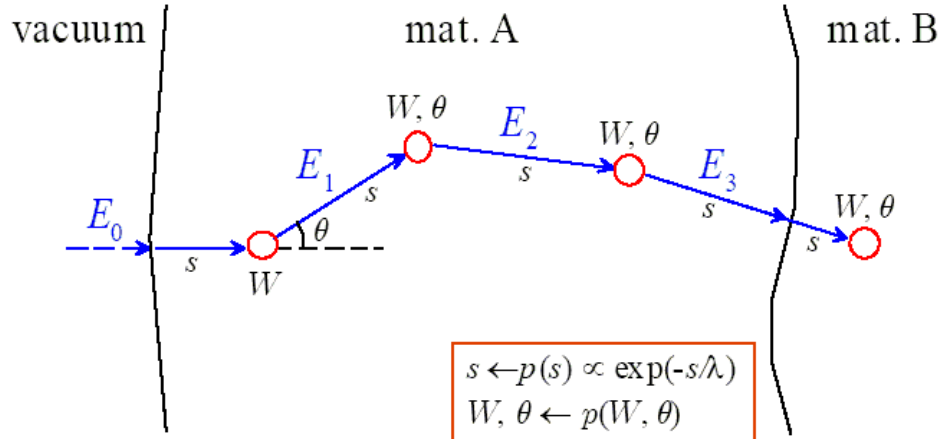

- The method is nominally exact (for energies higher than ~ 1 keV)
- Feasible only for **photons** and **low-energy electrons and positrons**
- High-energy electrons and positrons are more difficult...

CERN 27/06/2006

γ 10 MeV in Aluminium

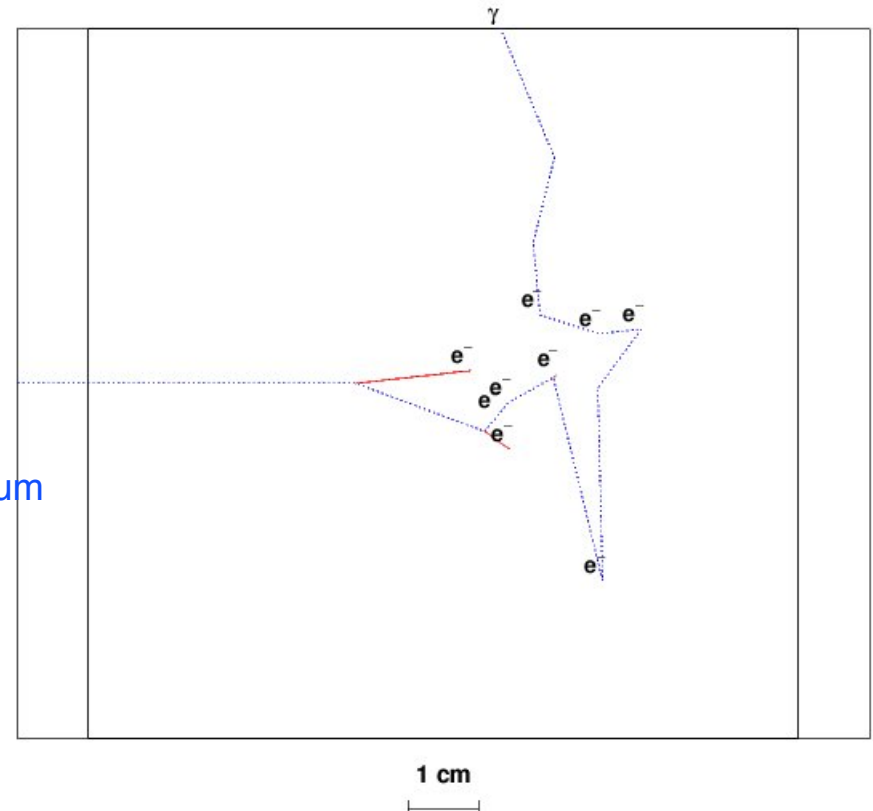

Simulation of charged particles ($e^{-/+}$)

- Deflection of charged particles in the Coulomb field of nuclei.
 - small deviation; practically no energy loss
- In finite thickness, particles suffer many repeated elastic Coulomb scattering
 - $> 10^6$ interactions / mm
- The cumulative effect is a net deflection from the original particle direction
- Individual elastic collisions are grouped together to form 1 multiple scattering

→ condensed history technique (class 1 algorithms)

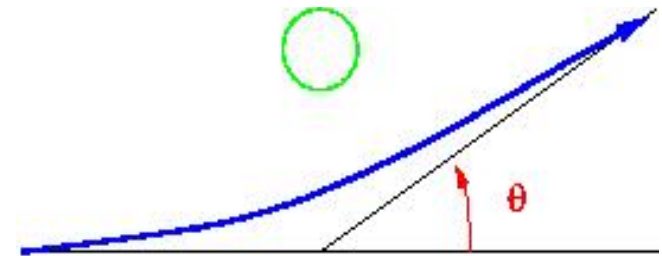

single atomic deviation

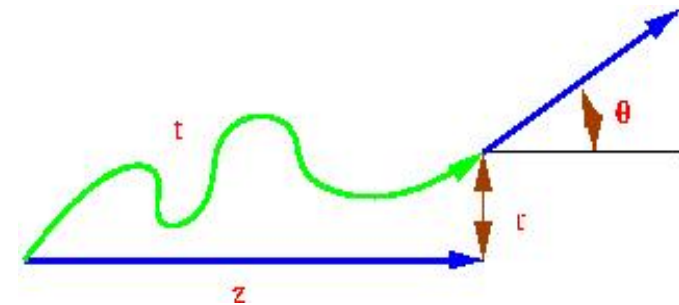

macroscopic view

Multiple Coulomb scattering (1)

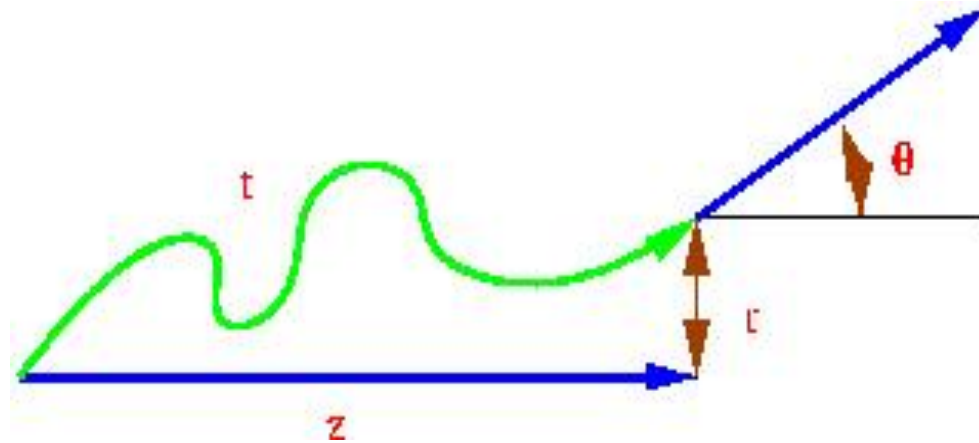

- longitudinal displacement : z (or geometrical path length)
- lateral displacement : r, Φ
- true (or corrected) path length : t
- angular deflection : θ, ϕ

Multiple Coulomb scattering (2)

Angular distribution of 2 MeV proton after 5 mic. Au

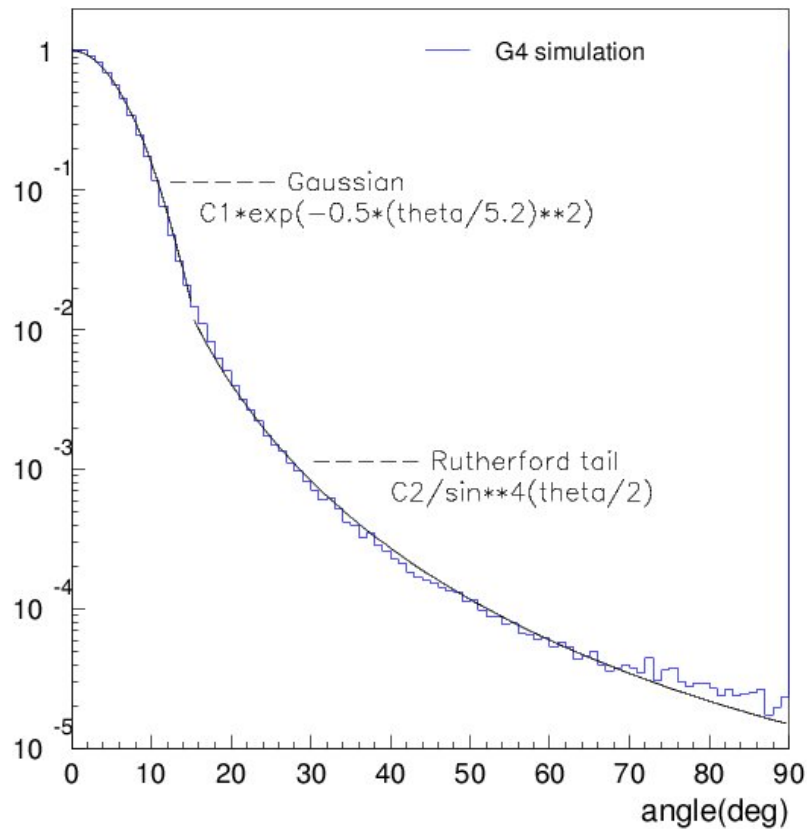

Angular distribution of 15.7 MeV e- after Au foils

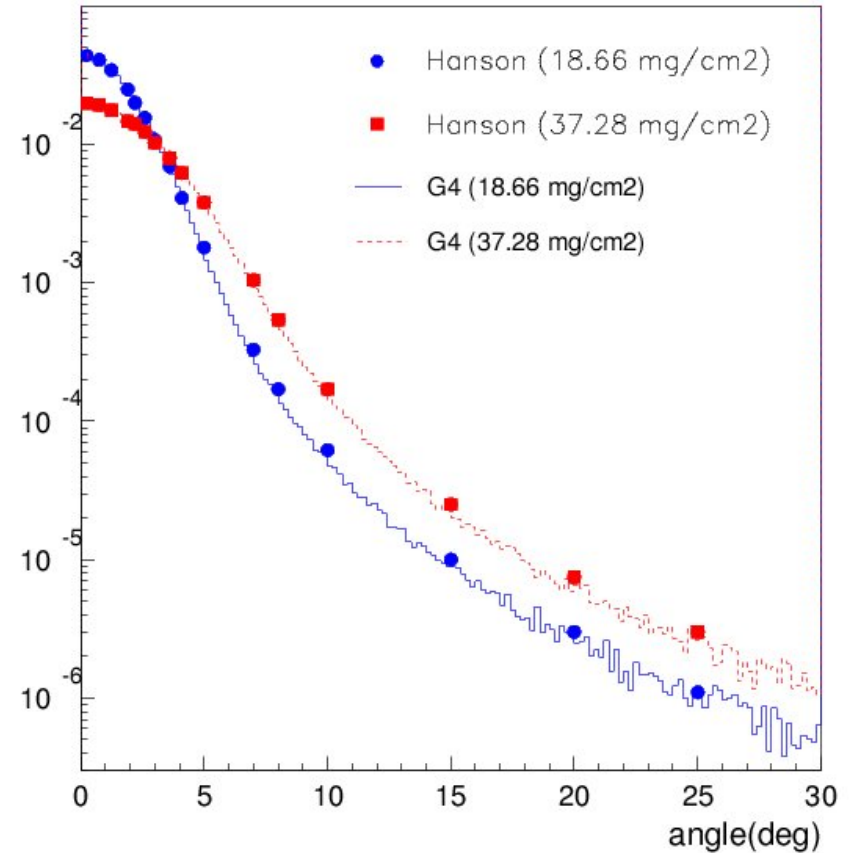

Multiple Coulomb scattering (3)

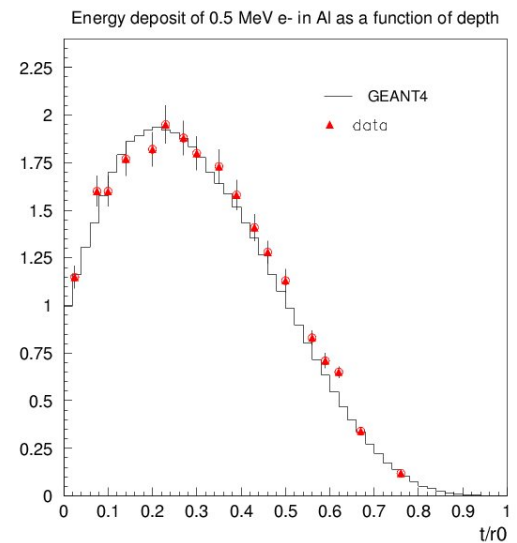
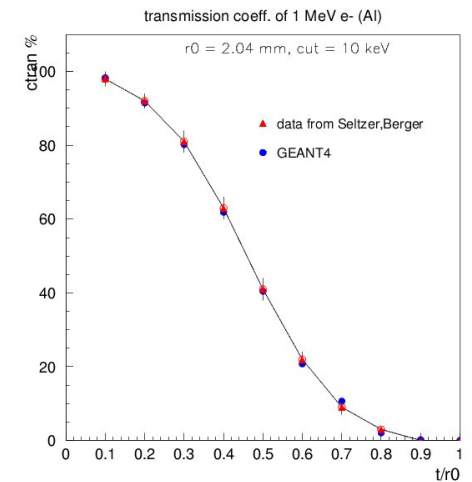
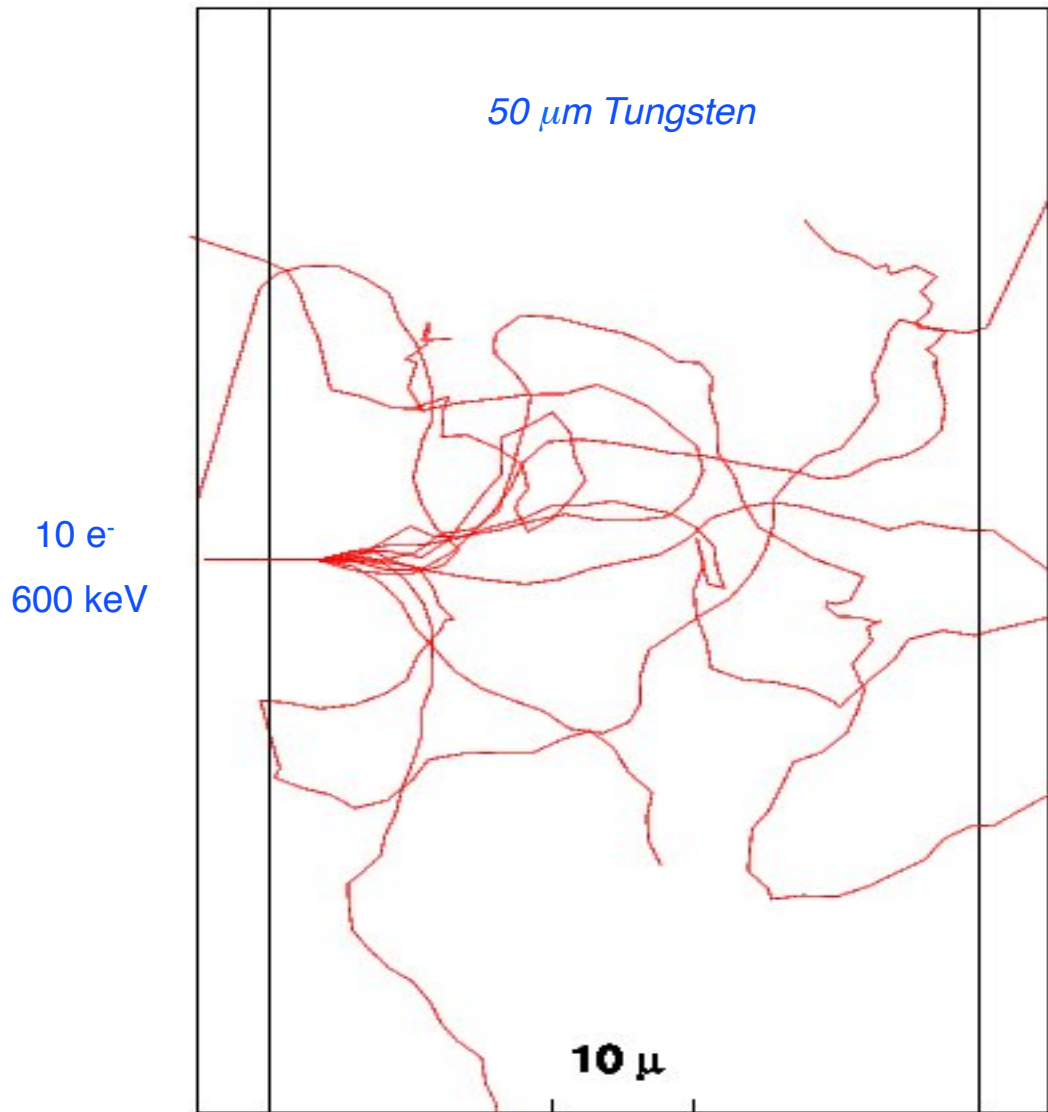

Ionization (1)

A charged particle hits a quasi-free electron (δ -ray)

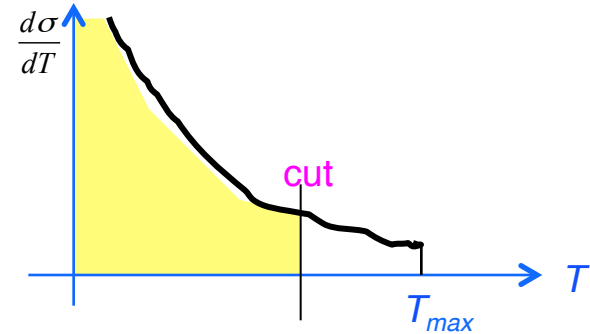
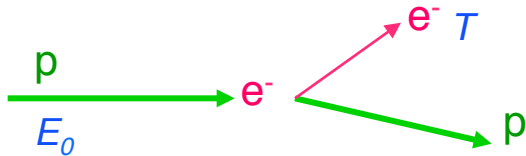

$\frac{d\sigma(E_0, T)}{dT}$: cross section for the ejection of an e^- of energy T

mean energy of a 'soft' e^- : $\langle T_{soft}(E_0) \rangle_{cut} = \frac{1}{\sigma_{tot}} \int_0^{cut} \frac{d\sigma(E_0, T)}{dT} T dT$

mean energy lost by the projectile due to sub cutoff e^- : $\left(\frac{dE}{dx} \right)_{cut} = n_{at} \sigma_{tot} \langle T_{soft} \rangle_{cut}$

cross section for creation of an e^- with $T > cut$: $\sigma(E_0, cut) = \int_{cut}^{T_{max}} \frac{d\sigma(E_0, T)}{dT} dT$

Ionization (2)

mean energy lost by the projectile due to sub cutoff e^- : $\left(\frac{dE}{dx}\right)_{cut} = n_{at} \sigma_{tot} \langle T_{soft} \rangle_{cut}$

→ accounted in the condensed history of the incident particle

dE/dx is called (restricted) stopping power or linear energy transferred

cross section for creation of an e^- with $T > cut$: $\sigma(E_0, cut) = \int_{cut}^{T_{max}} \frac{d\sigma(E_0, T)}{dT} dT$

→ explicit creation of an e^- : analogue simulation

Ionization (3)

'hard' inelastic collisions \rightarrow δ -rays emission

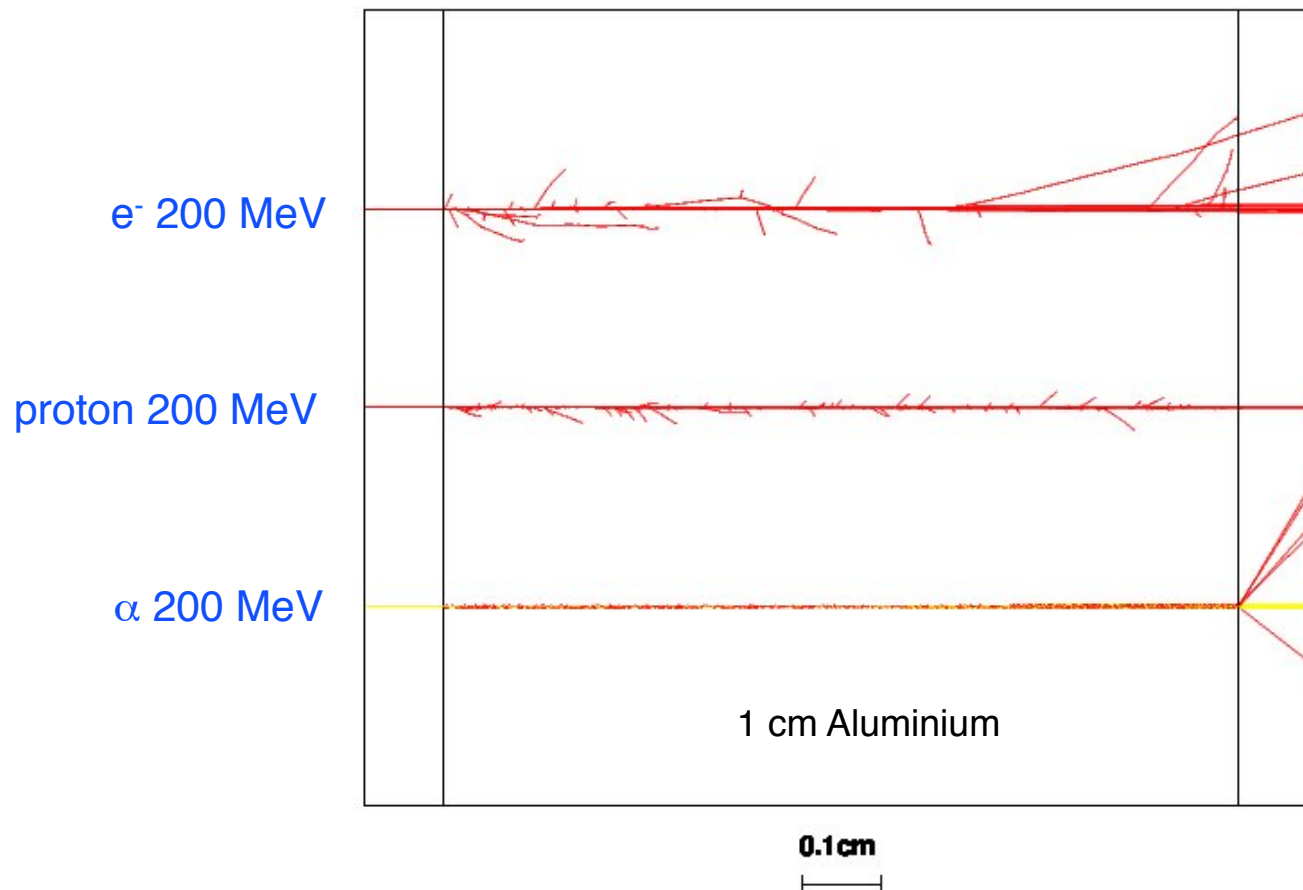

Ionization (4)

straggling : $\Delta E = [\Delta E] + \text{fluctuations}$

e^- 16 MeV in water

(*muls off*)

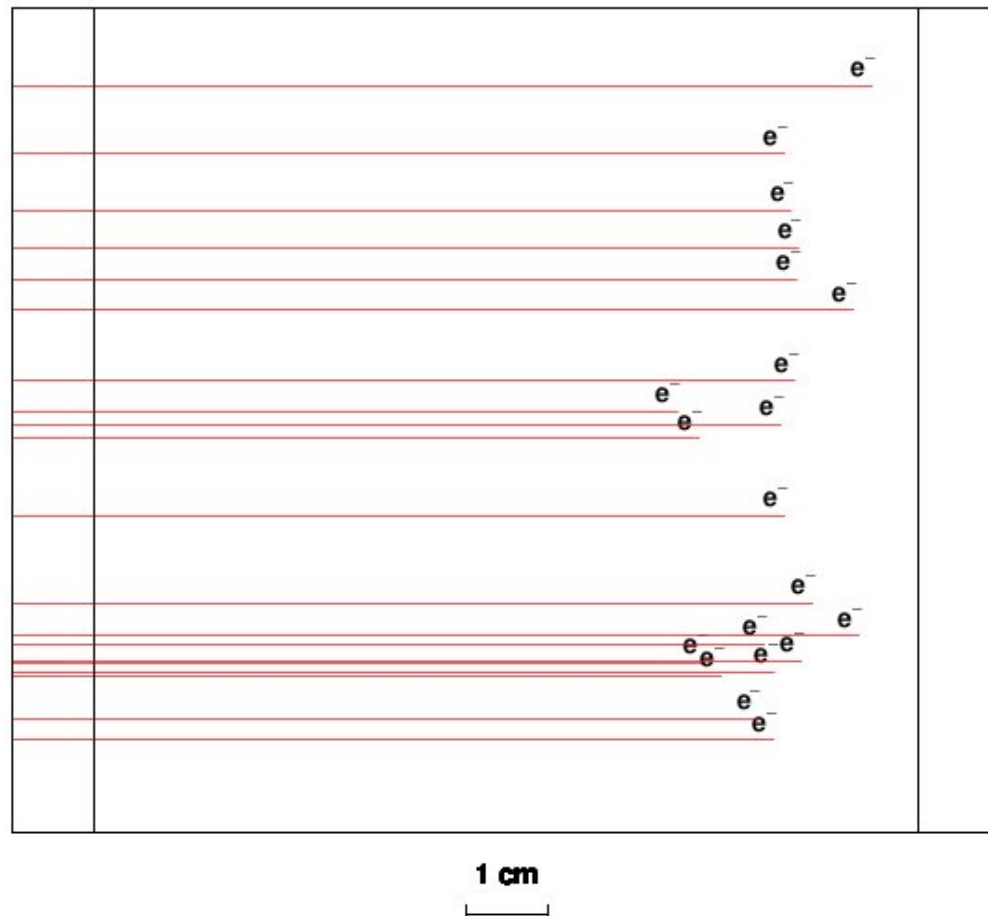

Condensed history algorithms

group many charged particles track segments into one single 'condensed' step

grouped collisions

- elastic scattering on nucleus
 - multiple Coulomb scattering
- soft inelastic collisions
 - collision stopping power (restricted)
- soft bremsstrahlung emission
 - radiative stopping power (restricted)

discrete collisions

- 'hard' δ -ray production
 - energy > cut
- 'hard' bremsstrahlung emission
 - energy > cut
- positron annihilation

Principle of Monte Carlo dose computation

- Simulate a large number of particle histories until all primary and secondary particles are absorbed or have left the calculation grid
- Calculate and store the amount of absorbed energy of each particle in each region (voxel)
- The statistical accuracy of the dose is determined by the number of particle histories

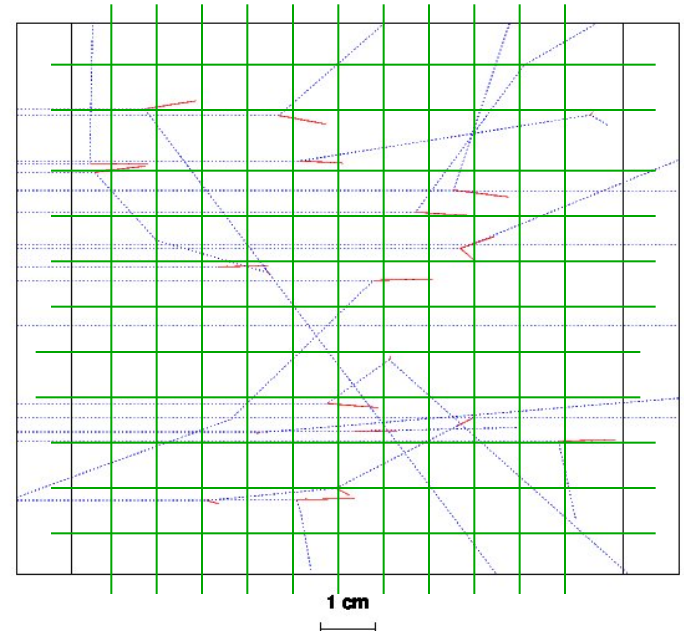

$$\text{mean value : } \langle D \rangle = \frac{1}{N} \sum_{i=1}^N D_i$$

$$\text{root mean square (rms) : } \sigma = \sqrt{\langle D^2 \rangle - \langle D \rangle^2}$$

$$\text{precision on mean : } \Delta D = \frac{\sigma}{\sqrt{N}}$$

A non exhaustive list of MC codes (1)

- ETRAN (Berger, Seltzer; NIST 1978)
- EGS4 (Nelson, Hirayama, Rogers; SLAC 1985)
www.slac.stanford.edu/egs
- EGS5 (Hirayama et al; KEK-SLAC 2005)
rcwww.kek.jp/research/egs/egs5.html
- EGSnrc (Kawrakow and Rogers; NRCC 2000)
www.irs.inms.nrc.ca/inms/irs/irs.html
- Penelope (Salvat et al; U. Barcelona 1999)
www.nea.fr/lists/penelope.html

A non exhaustive list of MC codes (2)

- **Fluka** (Ferrari et al; CERN-INFN 2005)
www.fluka.org
- **Geant3** (Brun et al; CERN 1986)
www.cern.ch
- **Geant4** (Apostolakis et al; CERN++ 1999)
geant4.web.cern.ch/geant4
- **MARS** (James and Mokhov; FNAL)
www-ap.fnal.gov/MARS
- **MCNPX/MCNP5** (LANL 1990)
mcnpx.lanl.gov