

NA62

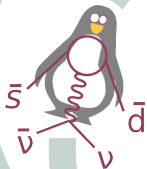

# The NA62 Experiment

Seminar at LAPP, Annecy, France

Mathieu PERRIN-TERRIN

CERN, Geneva, Switzerland.

January 15, 2016

# Outline

- 1 Physics Case (10min)
- 2 The NA62 Experiment (25min)
- 3 First look at Data (10min)
- 4 Conclusions and Prospects

# A broad physics program

**The main target:  $K^+ \rightarrow \pi^+ \nu \bar{\nu}$  but many more channels:**

Decay	Physics	Present limit (90% C.L.) / Result	NA62
$\pi^+ \mu^+ e^-$	LFV	$1.3 \times 10^{-11}$	$0.7 \times 10^{-12}$
$\pi^+ \mu^- e^+$	LFV	$5.2 \times 10^{-10}$	$0.7 \times 10^{-12}$
$\pi^- \mu^+ e^+$	LNV	$5.0 \times 10^{-10}$	$0.7 \times 10^{-12}$
$\pi^- e^+ e^+$	LNV	$6.4 \times 10^{-10}$	$2 \times 10^{-12}$
$\pi^- \mu^+ \mu^+$	LNV	$1.1 \times 10^{-9}$	$0.4 \times 10^{-12}$
$\mu^- \nu e^+ e^+$	LNV/LFV	$2.0 \times 10^{-8}$	$4 \times 10^{-12}$
$e^- \nu \mu^+ \mu^+$	LNV	No data	$10^{-12}$
$\pi^+ X^0$	New Particle	$5.9 \times 10^{-11} m_{X^0} = 0$	$10^{-12}$
$\pi^+ \chi \chi$	New Particle	-	$10^{-12}$
$\pi^+ \pi^+ e^- \nu$	$\Delta S \neq \Delta Q$	$1.2 \times 10^{-8}$	$10^{-11}$
$\pi^+ \pi^+ \mu^- \nu$	$\Delta S \neq \Delta Q$	$3.0 \times 10^{-6}$	$10^{-11}$
$\pi^+ \gamma$	Angular Mom.	$2.3 \times 10^{-9}$	$10^{-12}$
$\mu^+ \nu_h, \nu_h \rightarrow \nu \gamma$	Heavy neutrino	Limits up to $m_{\nu_h} = 350 \text{ MeV}$	
$R_K$	LU	$(2.488 \pm 0.010) \times 10^{-5}$	$\gg 2 \text{ better}$
$\pi^+ \gamma \gamma$	$\chi$ PT	< 500 events	$10^5 \text{ events}$
$\pi^0 \pi^0 e^+ \nu$	$\chi$ PT	66000 events	$O(10^6)$
$\pi^0 \pi^0 \mu^+ \nu$	$\chi$ PT	-	$O(10^5)$

keeping growing: axion search

# $K^+ \rightarrow \pi^+ \nu \bar{\nu}$ : a rare and clean decay

- **Flavour Changing Neutral Current**: no tree diagrams, hard GIM suppression

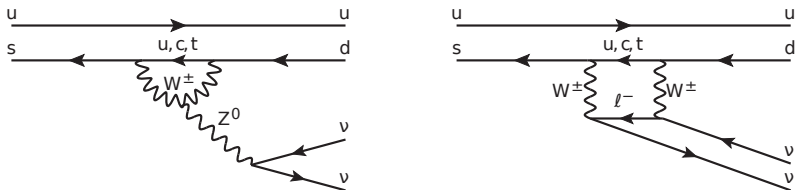

- Very **rare** SM process [Buras, 1503.02693]

$$\mathcal{B}(K^+ \rightarrow \pi^+ \nu \bar{\nu}) = (8.4 \pm 1.0) \times 10^{-11}$$

- And very **clean**, we will see why...



# Anatomy of the Decay: Short and Long Ranges

- ▶ Virtual particles (VP) in loops are off-shell
- ▶ VPs propagate over  $\Delta t = 1/\Delta E$  (uncertainty principle)
- ▶ QCD energy scale  $\ll$  EW energy scale hence:

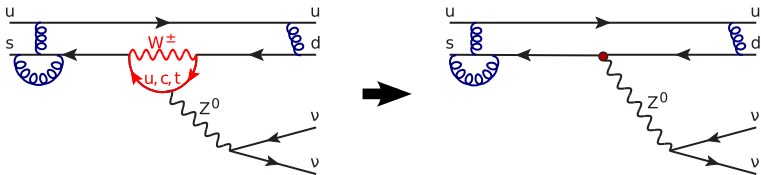

- ▶ **Short** and **long** ranges scale separate naturally [Buras 9806471]:

$$\mathcal{A}(M \rightarrow F) = \frac{G_F}{2} \sum_i V_{CKM}^i C_i(\mu) \langle F | Q_i(\mu) | M \rangle$$

$\langle F | Q_i(\mu) | M \rangle$

long range, matrix elements, **large uncertainties**

$C_i(\mu)$

short range, Wilson coefficients

# Anatomy of the Decay: Short and Long Ranges

- ▶ Virtual particles (VP) in loops are off-shell
- ▶ VPs propagate over  $\Delta t = 1/\Delta E$  (uncertainty principle)
- ▶ QCD energy scale  $\ll$  EW energy scale hence:

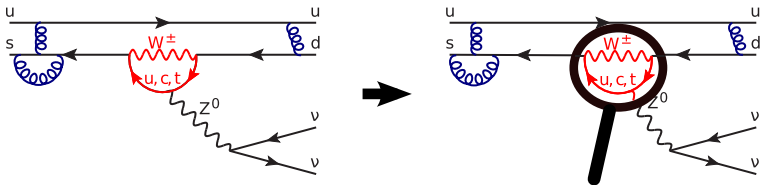

- ▶ **Short** and **long** ranges scale separate naturally [Buras 9806471]:

$$\mathcal{A}(M \rightarrow F) = \frac{G_F}{2} \sum_i V_{CKM}^i C_i(\mu) \langle F | Q_i(\mu) | M \rangle$$

$\langle F | Q_i(\mu) | M \rangle$   
 $C_i(\mu)$

long range, matrix elements, **large uncertainties**  
 short range, Wilson coefficients

# Theoretical Uncertainties

$$\mathcal{A}(M \rightarrow F) = \frac{G_F}{2} \sum_i V_{CKM}^i C_i(\mu) \langle F | Q_i(\mu) | M \rangle$$

## Matrix Elements (normally large uncertainties)

- ▶ Derived from  $K^+ \rightarrow \pi^0 e^+ \nu$  using isospin symmetry:

$$\langle \pi^+ | (\bar{s}d)_{V-A} | K^+ \rangle = \sqrt{2} \langle \pi^0 | (\bar{s}u)_{V-A} | K^+ \rangle$$

## Wilson Coefficients

- ▶ **NLO** QCD correction for top, **NNLO** for charm
- ▶ **NLO** EW correction for top & charm

## SM Predictions [Buras 1503.02693]

$$\mathcal{B}(K^+ \rightarrow \pi^+ \nu \bar{\nu}) = (8.4 \pm 0.3 \pm 1.0_{\text{ext}}) \times 10^{-11}$$

- ▶ Second error from **external CKM inputs** ( $V_{cb}$ ,  $\gamma$ )

# Testing the Standard Model

- ▶  $\mathcal{B}(K^+ \rightarrow \pi^+ \nu \bar{\nu})$  with 10% uncertainties allows to determine  $|V_{td}|$  at 9% [Buras 0405132]
- ▶ With  $\mathcal{B}(K^+ \rightarrow \pi^+ \nu \bar{\nu})$ ,  $\mathcal{B}(K_L \rightarrow \pi^0 \nu \bar{\nu})$ <sup>1</sup> the CKM unitarity triangle can be built independently from B observables:

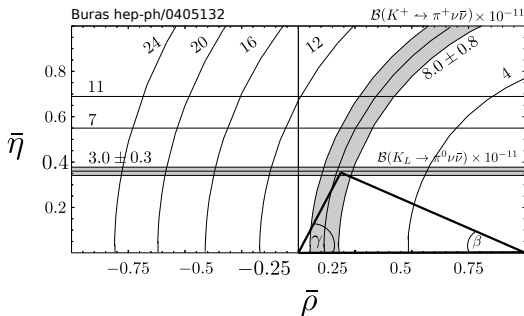

<sup>1</sup>KOTO: SM single event sensitivity by 2020

# Going Beyond the Standard Model

- ▶ Any 10% deviation from  $\mathcal{B}_{SM}$  would **signal new particles** (e.g. vector boson) contributions
- ▶ Even more sensitive to NP when using **correlations** with  $\mathcal{B}(K_L \rightarrow \pi^0 \nu \bar{\nu})$ ,  $\mathcal{B}(B_s^0 \rightarrow \mu\mu)$ ,  $\gamma$ ,  $B \rightarrow K(K^*)\mu\mu$ ,  $\epsilon'/\epsilon$
- ▶ A key observable for the LHC era

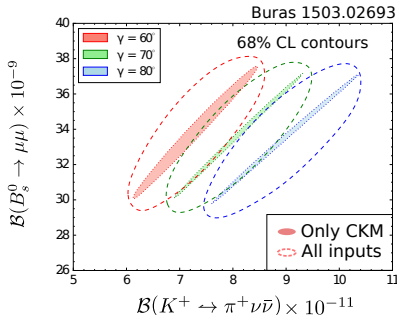
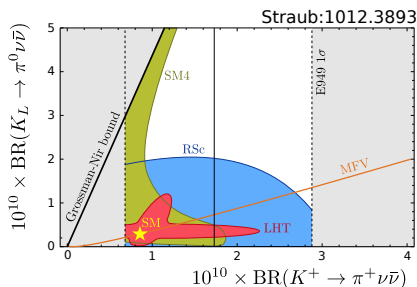

# State of the Searches

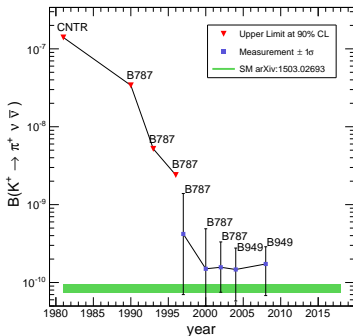

## E949 Measurements – 2008

- ▶ Stopping kaon technique

$$\mathcal{B}(K^+ \rightarrow \pi^+ \nu \bar{\nu}) = (1.73^{+1.15}_{-1.05}) \times 10^{-10}$$

Phys. Rev. D 77, 052003 (2008)

Phys. Rev. D 79, 092004 (2009)

- ▶ KOTO at JPARC aims to reach by 2020 the SM **single event sensitivity** for  $K_L \rightarrow \pi^0 \nu \bar{\nu}^2$

---

$$^2\mathcal{B}(K_L \rightarrow \pi^0 \nu \bar{\nu}) = (3.0 \pm 0.3) \times 10^{-11} \text{ Buras 1503.02693}$$

# State of the Searches

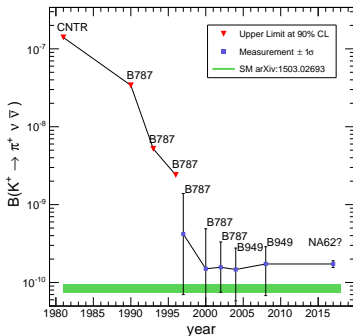

## E949 Measurements – 2008

- ▶ Stopping kaon technique

$$\mathcal{B}(K^+ \rightarrow \pi^+ \nu \bar{\nu}) = (1.73^{+1.15}_{-1.05}) \times 10^{-10}$$

Phys. Rev. D 77, 052003 (2008)

Phys. Rev. D 79, 092004 (2009)

- ▶ KOTO at JPARC aims to reach by 2020 the SM **single event sensitivity** for  $K_L \rightarrow \pi^0 \nu \bar{\nu}^2$

---

$$^2\mathcal{B}(K_L \rightarrow \pi^0 \nu \bar{\nu}) = (3.0 \pm 0.3) \times 10^{-11} \text{ Buras 1503.02693}$$

# NA62 Goal

- ▶ Measuring  $\mathcal{B}(K^+ \rightarrow \pi^+ \nu \bar{\nu})$  with 10% uncertainty in **2 years**
  - ▶  $O(100)$  signal events and Sig/Bkg  $O(10)$
- ▶ With a signal efficiency of  $\sim 10\%$ , it implies:
  - ▶  $10^{13}$  kaons in 2 years
  - ▶ background **rejection of  $10^{12}$**
- ▶ Use **SPS**: perfect for **decay in flight** technique



# Outline

- 1 Physics Case (10min)
- 2 The NA62 Experiment (25min)**
- 3 First look at Data (10min)
- 4 Conclusions and Prospects

# NA62 Collaboration

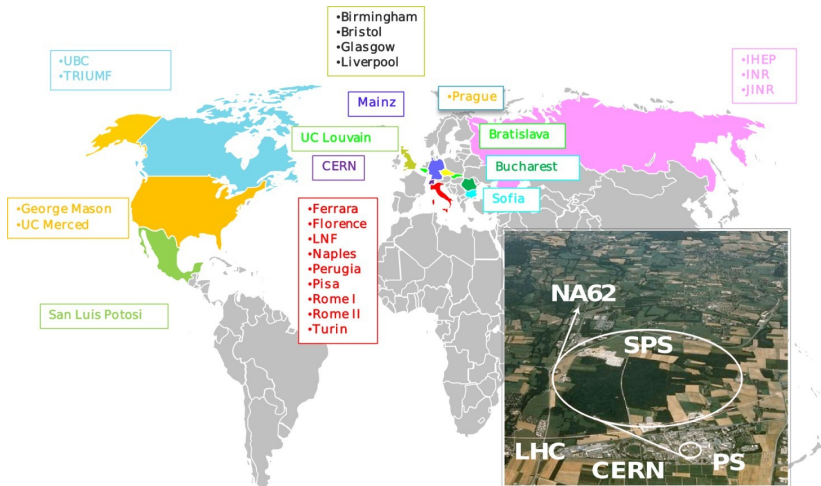

28 Institutes, ~200 Collaborators

# NA62 Time Line

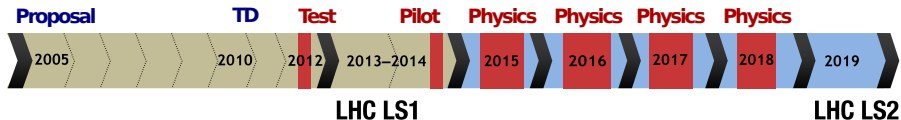

## Reference Documents

### 2005 Proposal

[CERN-SPSC-2005-013]

### 2010 Technical Design

[NA62-10-07]

### 2014 Pilot Run

[G. Ruggiero, CERN Seminar ]

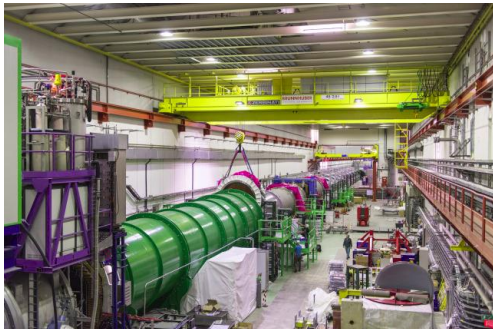

# NA62 Apparatus

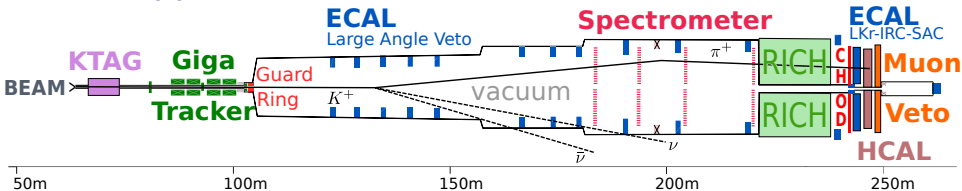

With HCAL and GTK completion in 2015 all detectors are installed

# NA62 Apparatus

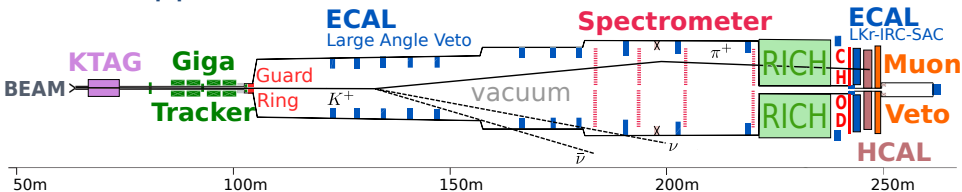

## Secondary Beam from SPS

- ▶ 5s spill at 750 MHz
- ▶ Composition:
 

$p$	$\pi^+$	$K^+$
70	24	6%
- ▶ 75 GeV/c with  $\delta p/p = 1\%$

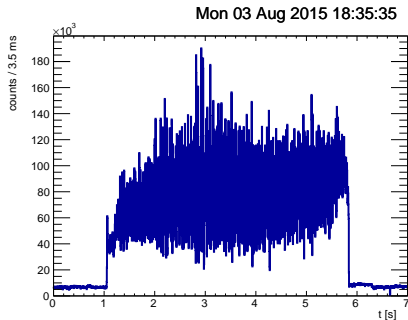

# NA62 Apparatus

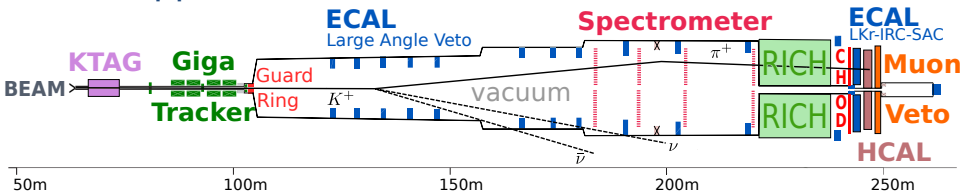

## Beam Instrumentation

- ▶ **Kaon Tagging** (KTAG, Differential Cerenkov  $N_2$  or  $H_2$ )
- ▶ **Kinematics** (GigaTracker- GTK, Silicon hybrid pixels)
- ▶ Beam particle **scattering detection** (Guard Ring)
- ▶ **Arrival time** measurement

# NA62 Apparatus

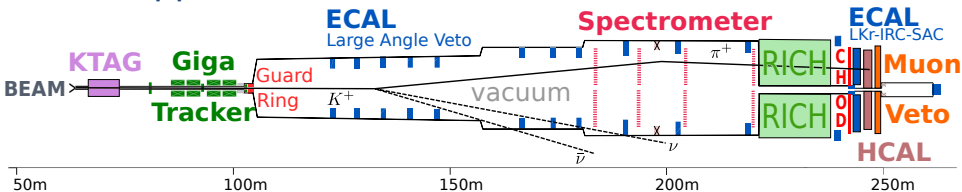

## Decay Region

- ▶ 120m long, in **vacuum** ( $500 \text{ m}^3$  at  $10^{-6}$  mbar)
- ▶ 10% of  $K^+$  decay in the first 65m:

5MHz of  $K^+$  decay,  $4.5 \times 10^{12}/\text{year}$

# NA62 Apparatus

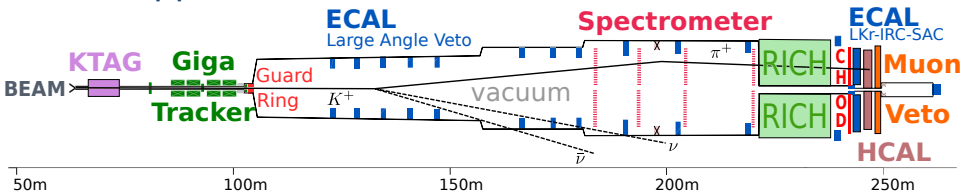

## Decay Products Instrumentation

- ▶ Kinematics (Spectrometer)
- ▶ Photon Detection (ECAL)
- ▶  $\pi$  and  $\mu$  identification (RICH, HCAL and, Muon Veto)
- ▶ Arrival time measurement (all + CHOD for charged particles)



# $K^+ \rightarrow \pi^+ \nu \bar{\nu}$ Analysis Strategy

## Background Sources

- ▶  $K^+$  decay incorrectly reconstructed
- ▶ Particle accidentally in time with a  $K^+$

## Analysis

- ▶ Main variable  $m_{miss}^2 = |p_K - p_\pi|^2$
- ▶ Look for signal in regions I and II
- ▶  $p_\pi \in [15, 35]$  GeV/c (RICH, kinematics,  $\gamma$  rejection, accidental from  $\pi^+ \rightarrow \mu^+ \nu$ )

- ▶ Background suppression needed:

Kinematics	$10^{-4}$	Charged PID	$10^{-7}$
$\pi^0$ 's $\gamma$ Rejection	$10^{-8}$	Timing	$10^{-2}$

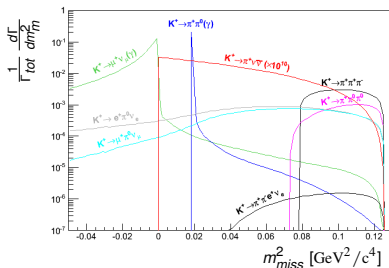
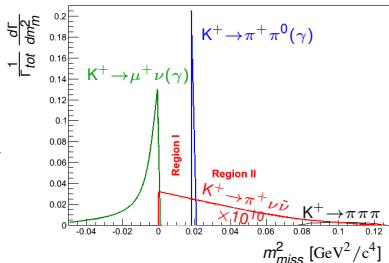

# Analysis Sensitivity (MC)

Decay	event/year
$K^+ \rightarrow \pi^+ \nu \bar{\nu}(\text{SM})$	45
<b>Total Background</b>	<b>10</b>
$K^+ \rightarrow \pi^+ \pi^0$	5
$K^+ \rightarrow \mu^+ \nu$	1
$K^+ \rightarrow \pi^+ \pi^+ \pi^-$	< 1
$K^+ \rightarrow \pi^+ \pi^- e^+ \nu$ + other 3 track decays	< 1
$K^+ \rightarrow \pi^+ \pi^0 \gamma^{\text{IB}}$	1.5
$K^+ \rightarrow \mu^+ \nu \gamma^{\text{IB}}$	0.5
$K^+ \rightarrow \pi^0 e^+ (\mu^+) \nu$ + others	negligible

# KTAG - Kaon Identification and Timing

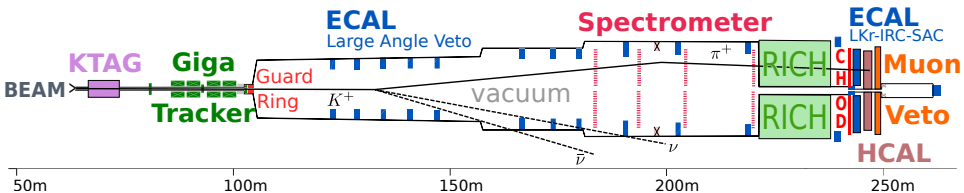

## Differential Cerenkov Detector

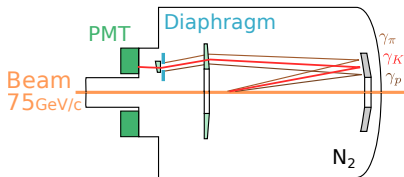

# KTAG - Performance

Time Resolution,  $\sigma(t) \leq 80$  ps

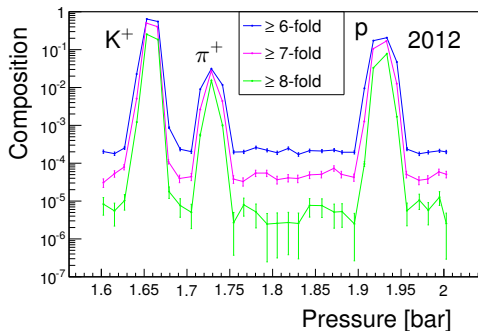
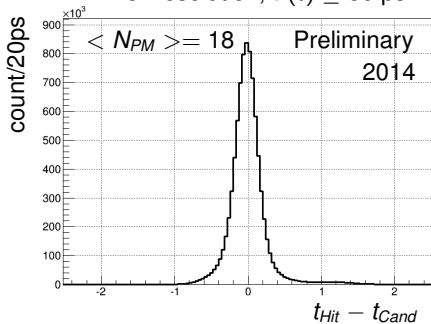

- ▶  $K^+$  Identification  $> 95\%$
- ▶  $\pi^+$ , p Rejection  $> 99.9\%$

# GTK - Beam Particle Kinematics and Timing

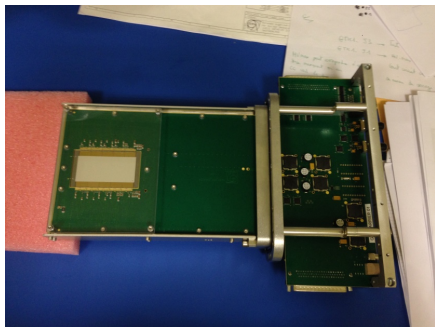
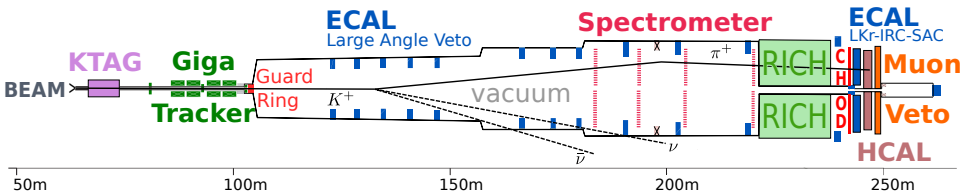

GTK3 in lab

## Three Stations of Silicon Hybrid Pixel

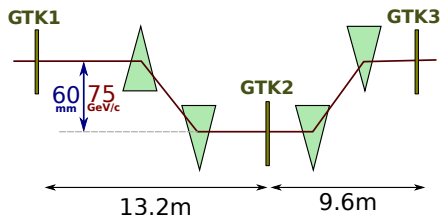

# GTK - Beam Particle Kinematics and Timing

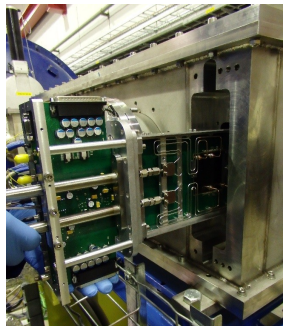
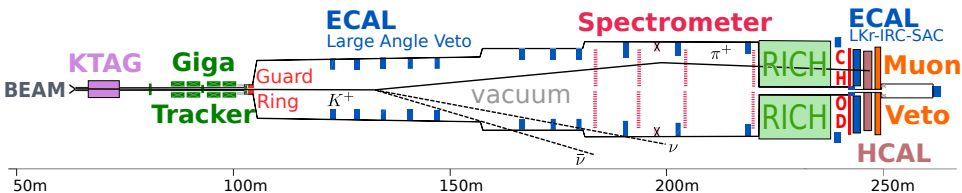

GTK3 being installed

## Three Stations of Silicon Hybrid Pixel

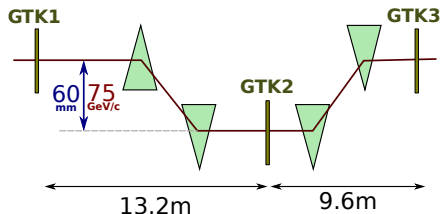

# A very innovative detector

Specifications	
Beam Rate	800 MHz - 1GHz 1.3 MHz/mm <sup>2</sup>
Radiation	$10^{14}$ 1MeV eq. n cm <sup>2</sup> /y
Momentum Reso	0.2%
Angular Reso	16 $\mu$ rad
Hit Time Reso	200 ps RMS
Material	$3 \times 0.5\% X_0$
Size	60mm $\times$ 27mm

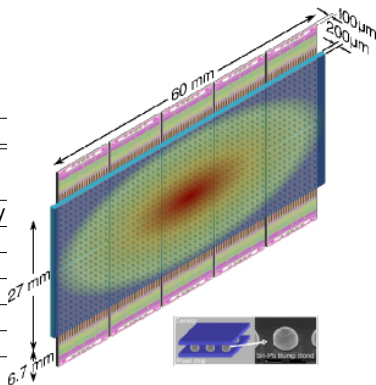

- ▶ Hybrid silicon pixels detector, changed every 100 run days
- ▶ 18k **time-resolved** pixels / station ( $300 \times 300 \mu\text{m}^2$ )
- ▶ ASIC thinned to  $100 \mu\text{m}$  operated in vacuum and cooled with **micro-channels**: **world first HEP implementation!**

# GTK - Time Measurement Principle

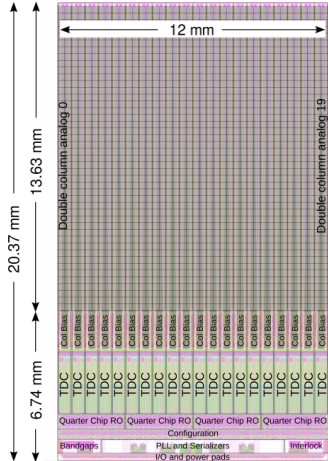



# GTK - Time Measurement Principle

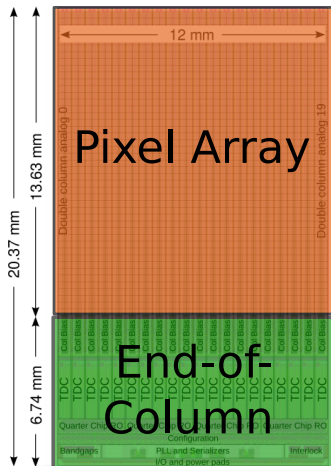

# GTK - Time Measurement Principle

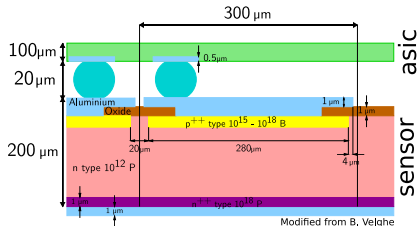
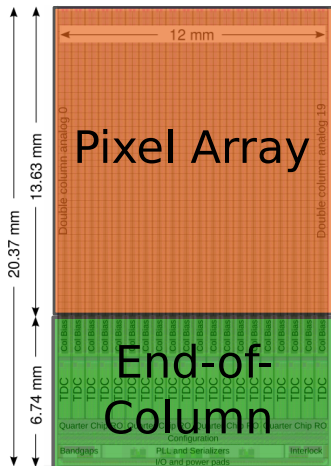

# GTK - Time Measurement Principle

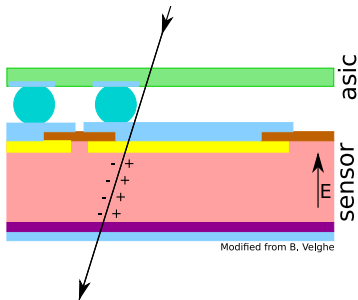
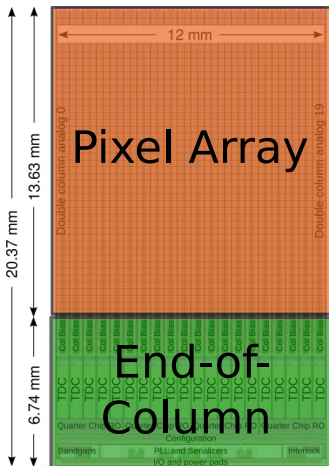

Modified from B. Velghe

Generated signal in GTK1

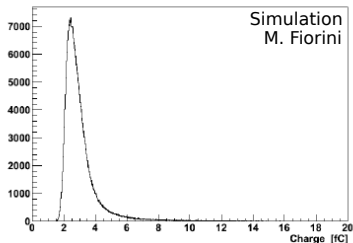

# GTK - Time Measurement Principle

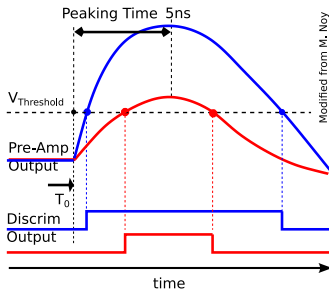
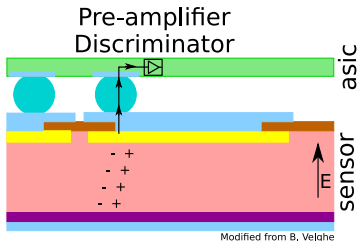
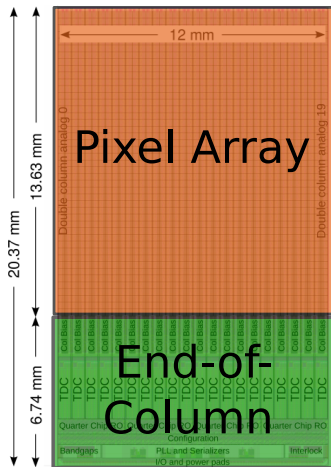

# GTK - Time Measurement Principle

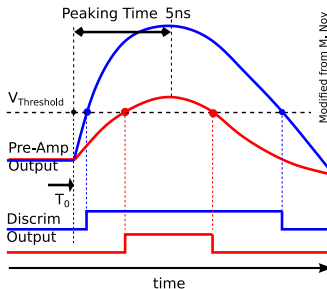
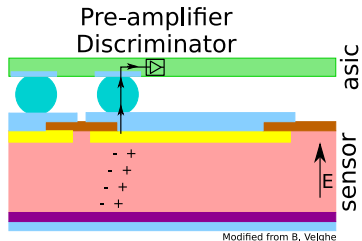
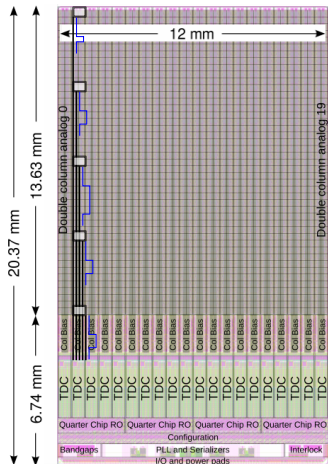

# GTK - Time Measurement Principle

- ▶ At EoC, TDCs measure **rising and falling** edge time
- ▶ The full GTK integrates **21,600 TDCs** in  $<25 \text{ cm}^2$ !
- ▶ Use Time-over-Threshold to estimate **time walk**

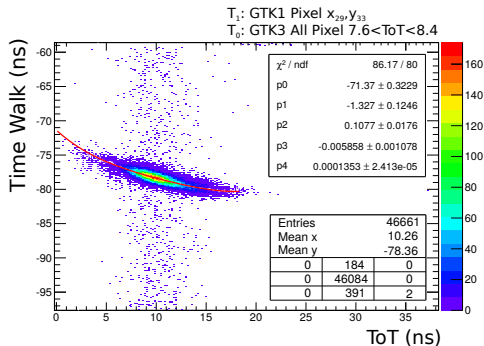
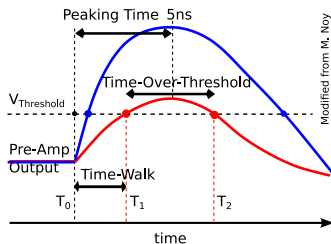

## GTK - MicroChannels Cooling

- ▶ Etch channels in a **130 $\mu\text{m}$  thin** Si plate glued on the ASICs
- ▶ Circulate cold  $\text{C}_6\text{F}_{14}$  in micro-channels (3.5 bars, 3 g/s)
- ▶ Fluid brought with capillaries **soldered on cooling plates**

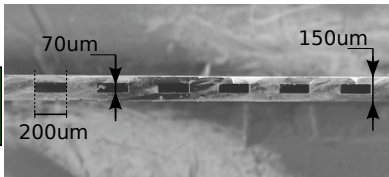
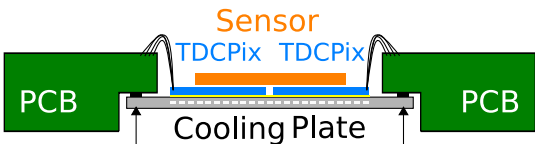

## GTK - MicroChannels Cooling

- ▶ Etch channels in a **130 $\mu\text{m}$  thin** Si plate glued on the ASICs
- ▶ Circulate cold  $\text{C}_6\text{F}_{14}$  in micro-channels (3.5 bars, 3 g/s)
- ▶ Fluid brought with capillaries **soldered on cooling plates**

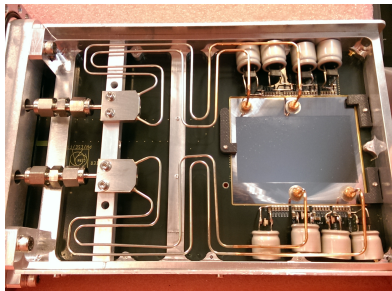
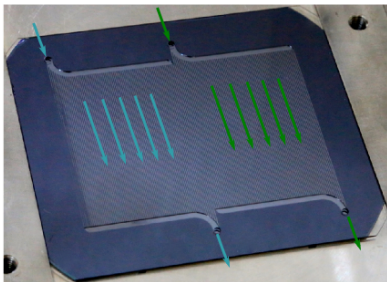



# GTK - Status and Performance

- ▶ Three stations **installed**, (2 thinned at  $100\mu\text{m}$ )
- ▶ 7-8 out of 10 chips per stations were working, fix next run
- ▶ Time resolution **260 ps per hit** (at 160V instead of 300V)  
see First Data for kinematics performance

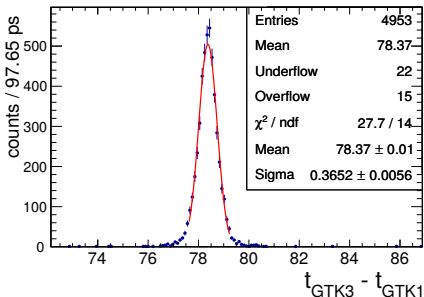

## Guard Ring - GTK3 Scattered Particle Detection

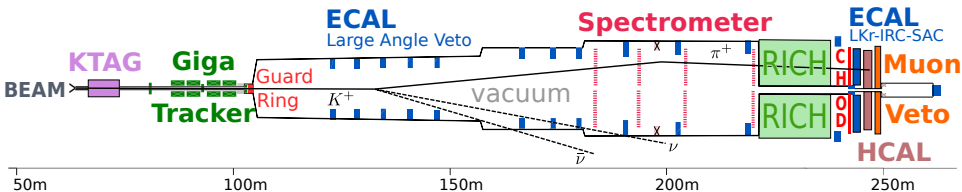

Five first Guard Ring stations during installation

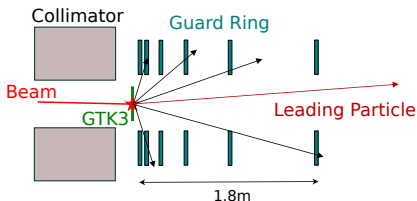

Specifications	
Rate	10-100kHz
Time Reso	1 ns

# CHANTI - Design and Performance

- ▶ 6 stations of **scintillator+WLS** fibres read with SiPMs
- ▶ Signal processed with **TDC**

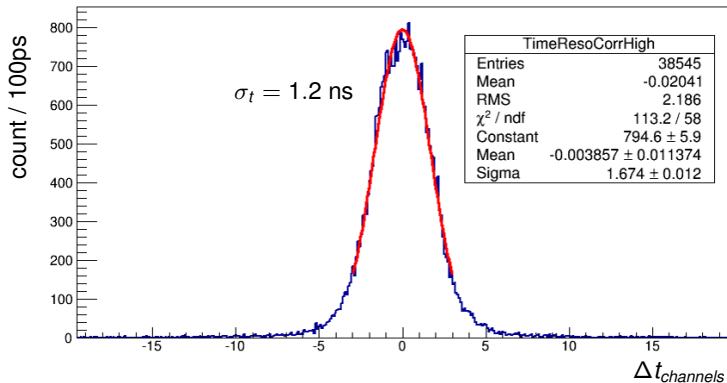

# CHOD - Charged Decay Product Timing

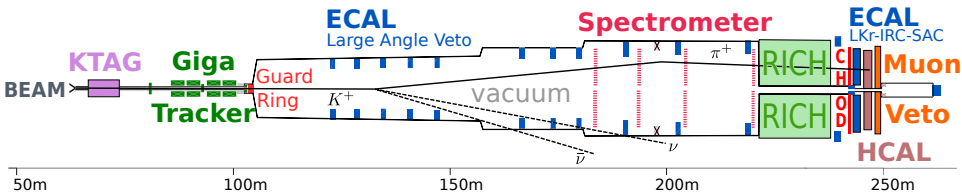

Time Resolution,  $\sigma(t) \simeq 300$  ps

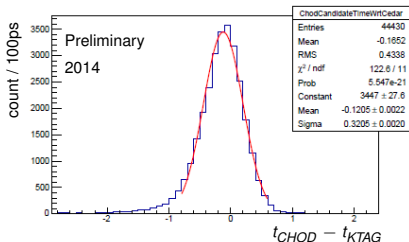

- ▶ 2 layers (X-Y) of **scintillator** read each by 64 PMT
- ▶ Used for **time reference**

# Spectrometer - Decay Products Kinematics

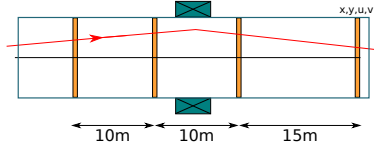
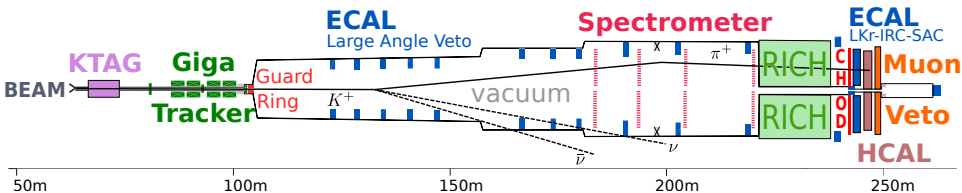

# Spectrometer - Design and Status

Specifications	
Rate	15 MHz
Momentum Reso	1%
Angular Reso	20-60 $\mu\text{rad}$
Material	$4 \times 0.5\% X_0$
Size	2.1 m diameter

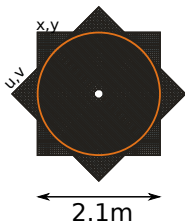

- ▶ 2.1m long straw filled with Ar+CO<sub>2</sub> at 1 atm ran in vacuum
- ▶ 7168 straws arranged in 4 chambers of 4 views (x,y,u,v)
- ▶ Readout up to 700kHz per straw with TDCs
- ▶ See performance in First Data

# ECAL - Photon Detection ( $K^+ \rightarrow \pi^+ \pi^0$ )

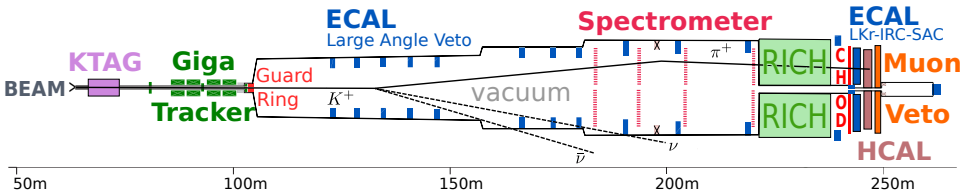

LAV Pb Glass - OPAL



8.5  $\rightarrow$  50 mrad

LKr NA48



1  $\rightarrow$  8.5 mrad

IRC (+ SAC) Shashlik type

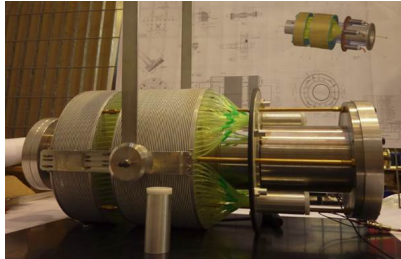

< 1 mrad: angular coverage

LAV: 8.5  $\rightarrow$  50 mrad

Specifications	
Eff.	99.8 - 99.99%
Time Reso	< 1 ns
Tot Rate	1MHz

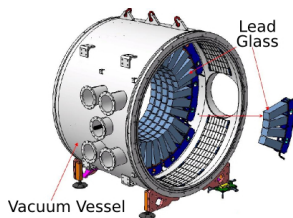

- ▶ 12 stations of 4-5 rings of staggered lead glass blocks

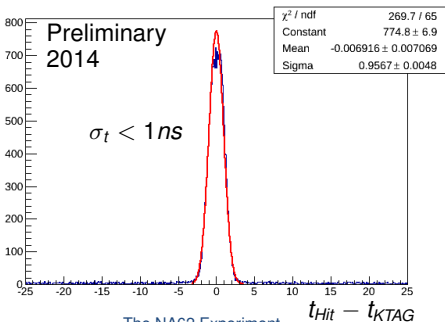



LKr: 1  $\rightarrow$  8.5 mrad

- ▶ Quasi homogenous liquid Krypton calorimeter from NA48
- ▶ Inefficiency measured in 2004 at  $10^{-5}$  for  $E > 10$  GeV
- ▶ Major RO upgrade: full LKr sampled at 40MHz with 14bits FADC

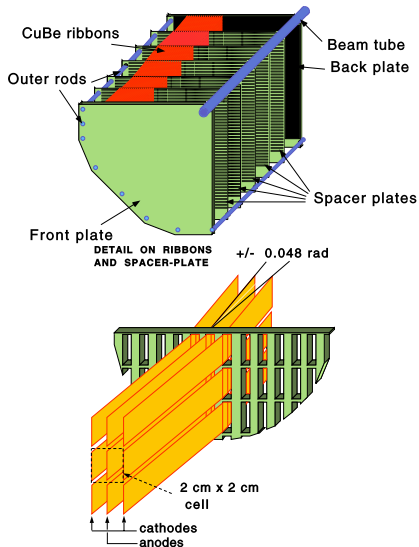

# LKr - Performance

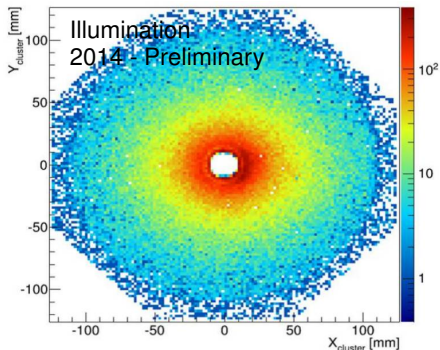

$$|p_K - p_{\pi^0}|^2$$

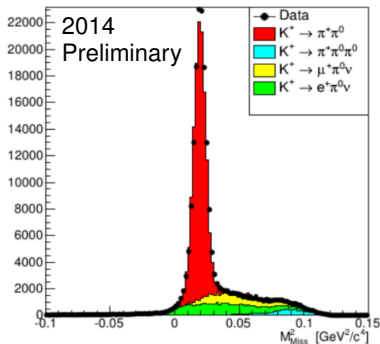

- ▶  $K^+ \rightarrow \pi^+\pi^0$  event reconstructed with **LKr only**
- ▶  $p_K$  set to its nominal value
- ▶  $\pi^0$  reconstructed from two EM clusters, constrained to  $m_{\pi^0}$

# RICH - $\pi$ , $\mu$ Identification

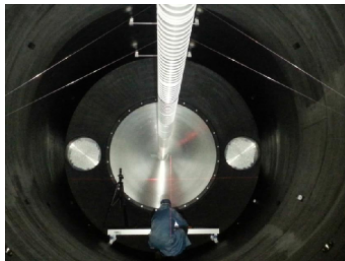
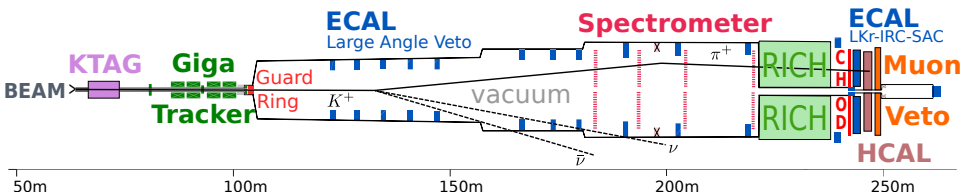

# RICH - Design

Specifications	
$\pi \rightarrow \mu$	$< 1\%$ for $p \in [15, 35]$ GeV
Angular Reso	$< 100 \mu\text{rad}$
Time Reso	$< 100$ ps RMS
Rate	10 MHz

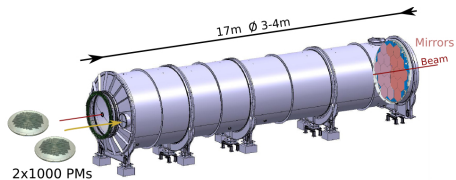

- ▶ Neon at 1 atm:

$$p_{Th}^{\pi} = 13 \text{ GeV}/c$$

- ▶ 17m long vessel:  
~20 hits per ring
- ▶ Light reflected on two 1000 PM arrays read with TDC

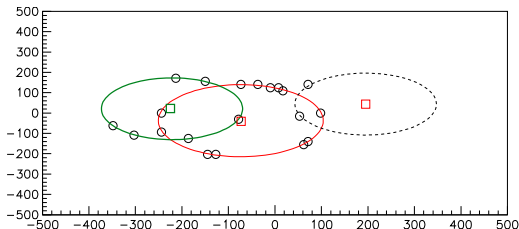

# RICH - Performance

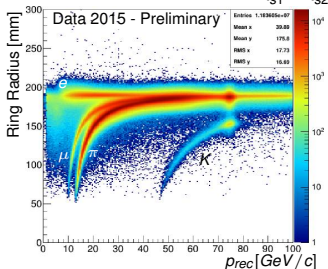
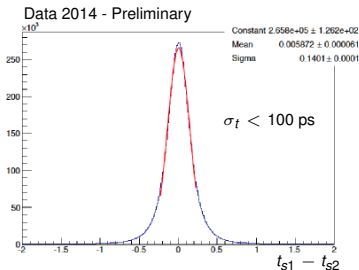

Data 2015 - Preliminary

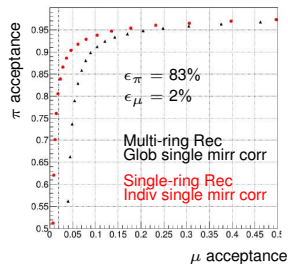
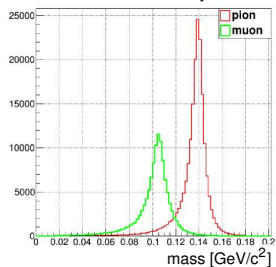

# HCAL and MUV - $\pi$ , $\mu$ Identification

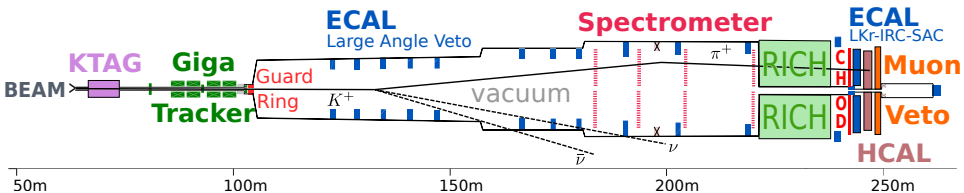

## HCAL 1 and 2



## MUV - back

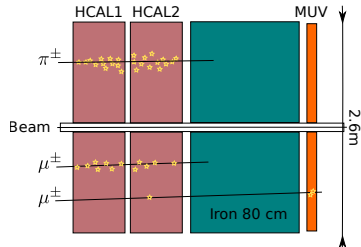

# MUV - Design and Performance

- MUV made of **scintillator** 22x22 cm<sup>2</sup> tiles read with 2 PMs and CFDs

Specifications	
$\pi \rightarrow \mu$	$< 10^{-2}$
Time Reso	$< 1\text{ ns RMS}$
Rate	10 MHz

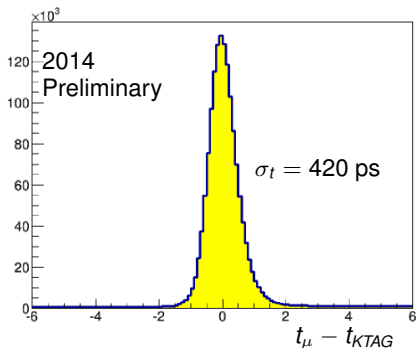
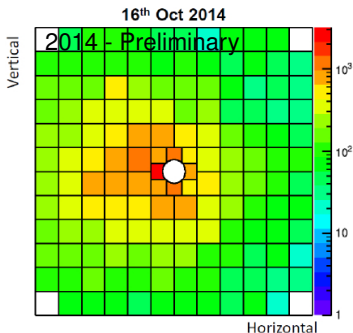

# HCAL 1 and 2 - Design and Performance

- ▶ HCAL1 (HCAL2) made of alternating layers of **iron** and 6 (12) cm **scintillator strip** read with PMs and TDCs

Specifications	
$\pi \rightarrow \mu$	$< 10^{-3}$
Time Reso	$< 1 \text{ ns RMS}$
Rate	10 MHz

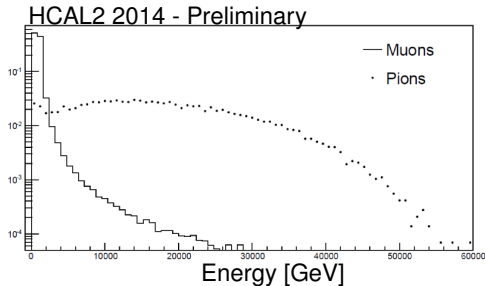
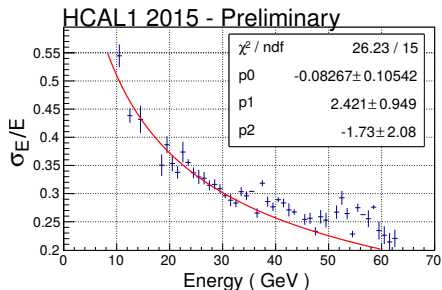



# Digital Trigger System

## System Feature

- ▶ As beam is not bunched triggers arrive asynchronously
- ▶ Digital inputs to L0TP

## 2015 Run

- ▶ System tested up to full intensity
- ▶ Digital calorimetric trigger implemented

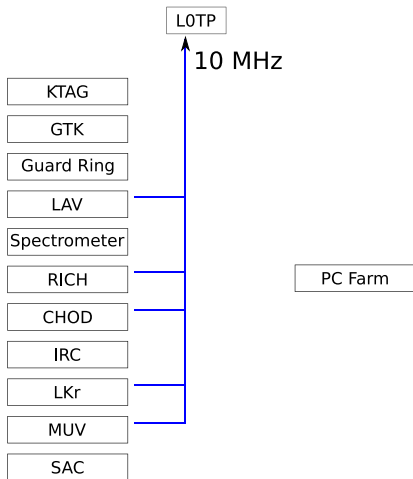

# Digital Trigger System

## System Feature

- ▶ As beam is not bunched triggers arrive asynchronously
- ▶ Digital inputs to L0TP

## 2015 Run

- ▶ System tested up to full intensity
- ▶ Digital calorimetric trigger implemented

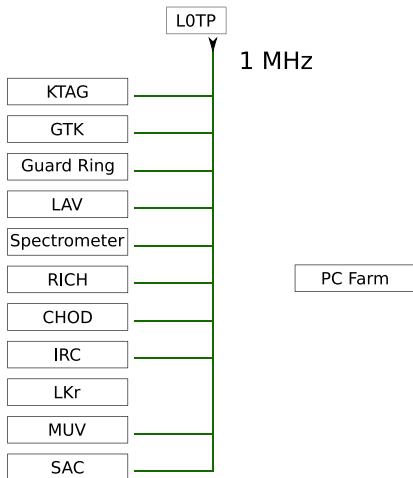

# Digital Trigger System

## System Feature

- ▶ As beam is not bunched triggers arrive asynchronously
- ▶ Digital inputs to L0TP

## 2015 Run

- ▶ System tested up to full intensity
- ▶ Digital calorimetric trigger implemented

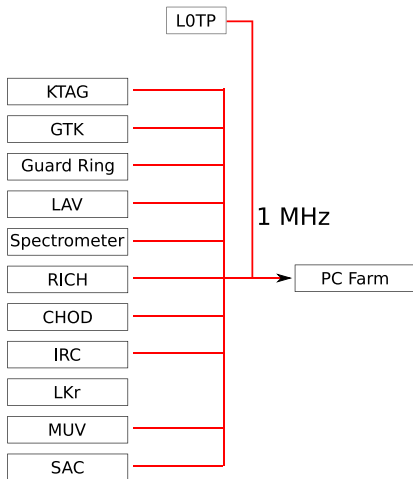

# Digital Trigger System

## System Feature

- ▶ As beam is not bunched triggers arrive asynchronously
- ▶ Digital inputs to L0TP

## 2015 Run

- ▶ System tested up to full intensity
- ▶ Digital calorimetric trigger implemented

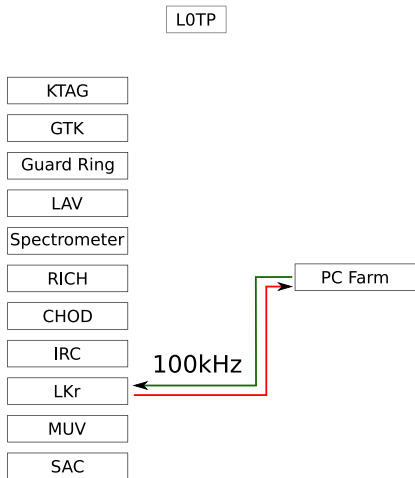

# Digital Trigger System

## System Feature

- ▶ As beam is not bunched triggers arrive asynchronously
- ▶ Digital inputs to L0TP

L0TP

## 2015 Run

- ▶ System tested up to full intensity
- ▶ Digital calorimetric trigger implemented

KTAG

GTK

Guard Ring

LAV

Spectrometer

RICH

CHOD

IRC

LKr

MUV

SAC

L2

PC Farm

20kHz  
on disk

# Calorimetric Trigger

- ▶ Full LKr **sampled at 40 MHz** with 14bits FADC
- ▶ Energies in one 25ns sampling of **16 (4x4) adjacent cells** summed and **pipe-lined in trigger boards**
- ▶ With 5 consecutive 16-cell sum, trigger boards look for **peaks in time** and fit to get **maximum** (i.e. energy)
- ▶ **Peak time** extracted by constant fraction discrimination
- ▶ Energy filled in a 6.25ns lsb histo

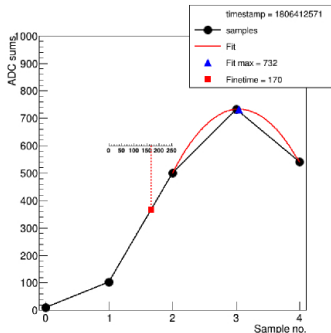

# Calorimetric Trigger Status and Prospects

## 2015 Run

- ▶ Machinery operated **synchronously on LKr and HCAL**
- ▶ Trigger based on **total energy** in LKr and HCAL1:

$$E_{HCAL1}^{tot} > 6 \text{ GeV} \quad \& \quad E_{LKr}^{tot} < 4 \text{ GeV}$$

## Prospects for Next Run

- ▶ LKr **clustering in space** (X and Y) at trigger level
- ▶ Trigger on **individual LKr cluster** instead of total energy

# Outline

- 1 Physics Case (10min)
- 2 The NA62 Experiment (25min)
- 3 First look at Data (10min)**
- 4 Conclusions and Prospects



# A look at min-bias 2014 and 2015 data

- ▶ **One track candidates:**  
Good  $\chi^2$  and 4(3)-chambers (in 2014)
- ▶ **K<sup>+</sup> kinematics:**  
Beam mean values in 2014, GTK in 2015
- ▶ Results **preliminary:**
  - ▶ B field constant
  - ▶ Drift-Time to Radius relation from MC (Garfield)
  - ▶ Rough detector alignment
  - ▶ Rough t0 (refined in 2015)

# Angle Track-Beam versus Track Momentum

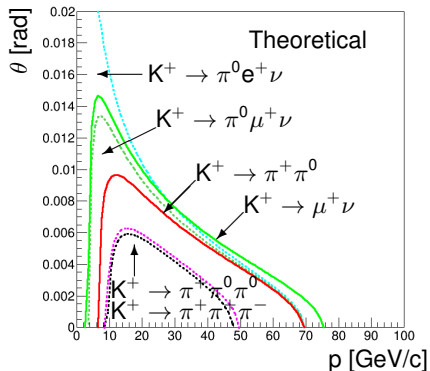
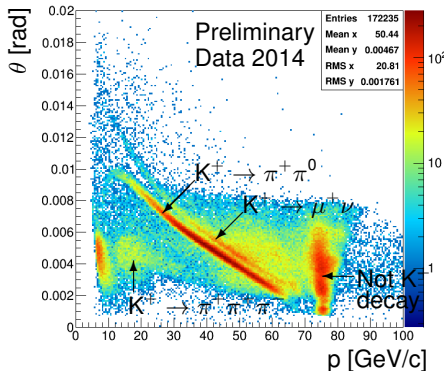

## Requesting in Time Kaon with KTAG

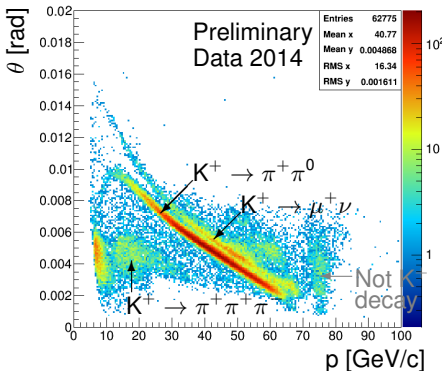
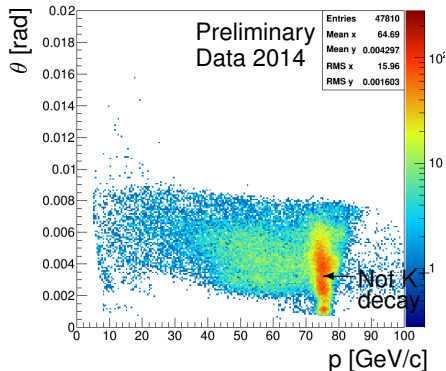
 $K^+$  in time with TrackNo  $K^+$  in time with Track

# Checking Track Id using RICH

## $K^+$ in time with Track

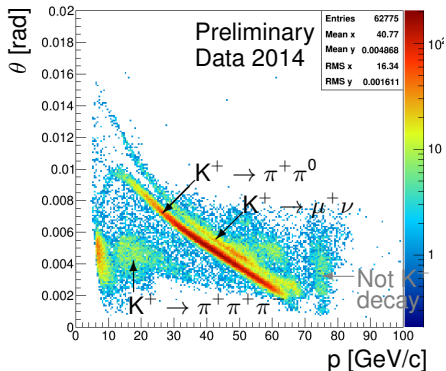

## Matched Ring in RICH

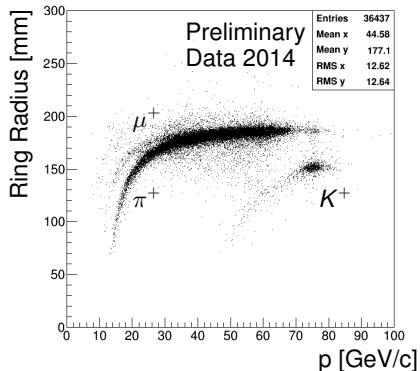

# Removing Scattered Beam Particle Component

$K^+$  in time with Track  
not scattered

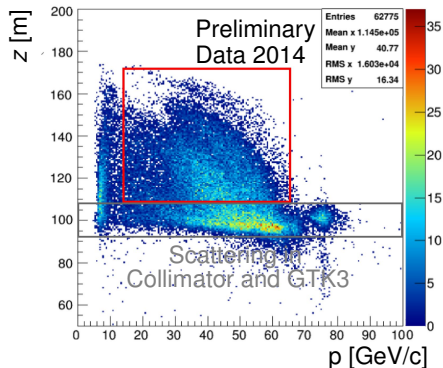
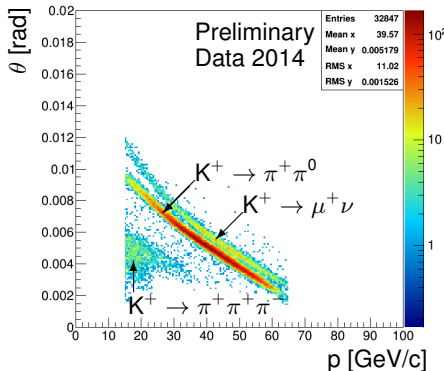

# Squared Missing Mass

$K^+$  in time with Track  
not scattered

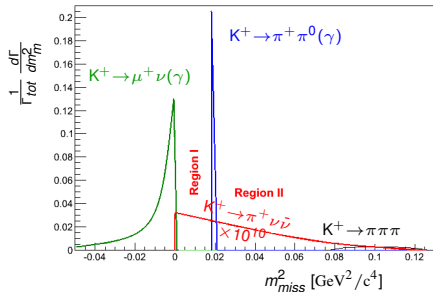
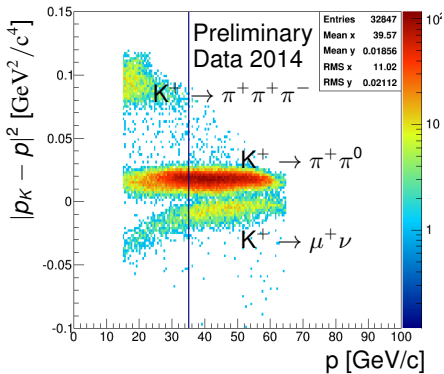

# Squared Missing Mass

$K^+$  in time with Track  
not scattered

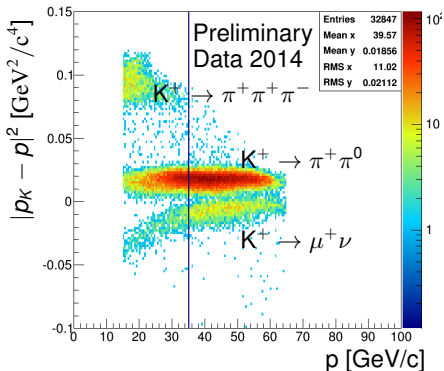

Reminder: No GTK

$p_\pi < 35 \text{ GeV}/c$

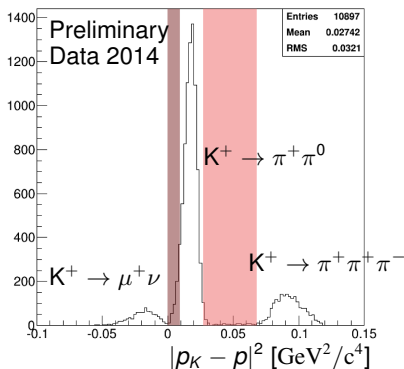

# More Discriminating Power using RICH mass

$K^+$  in time with Track  
not scattered

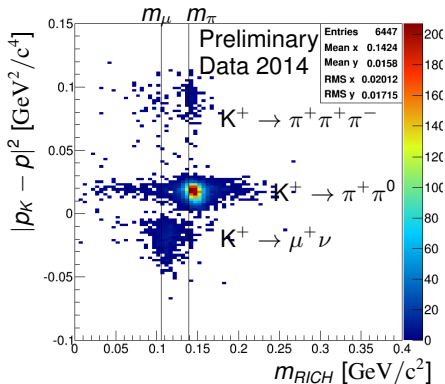
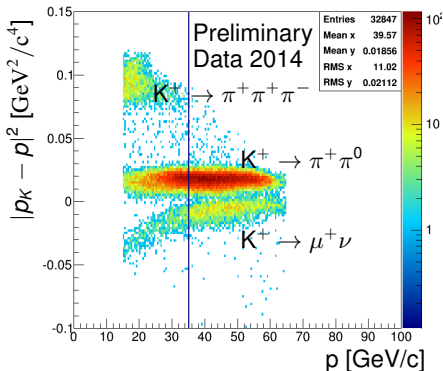



## Improving kinematics with GTK - 2015

$K^+$  in time with Track  
not scattered

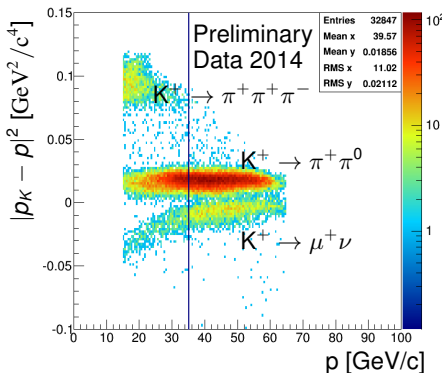

$p_{K^+}$  from GTK

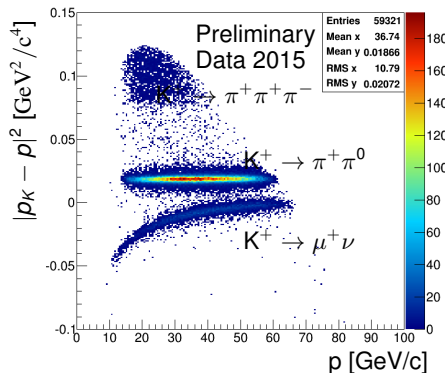

# Improving kinematics with GTK - 2015

Without GTK  
Full  $p$  range

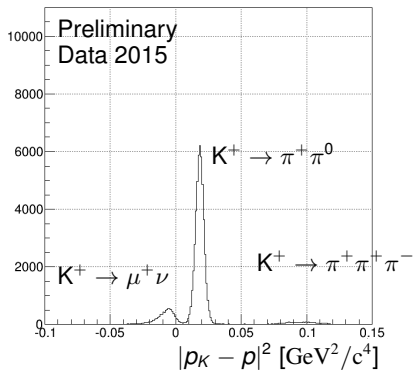

With GTK  
Full  $p$  range

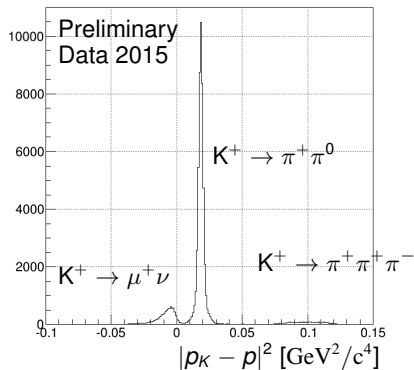

# Improving kinematics with GTK - 2015

## Missing Mass Resolution

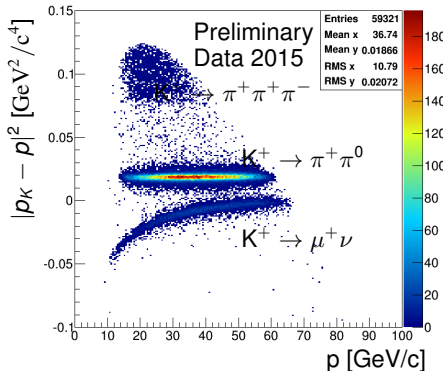
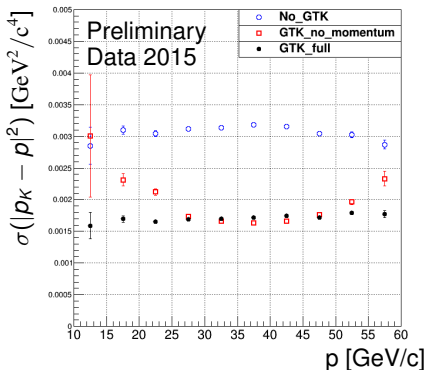

# Outline

- 1 Physics Case (10min)
- 2 The NA62 Experiment (25min)
- 3 First look at Data (10min)
- 4 Conclusions and Prospects**

# Conclusion and Prospects

- ▶  $B(K^+ \rightarrow \pi^+ \nu \bar{\nu})$  an important observable in LHC era
- ▶ NA62 apparatus **installed** and first **data taken**
- ▶ **New technologies** developed (time resolved pixel, micro-channel cooling) now considered for LHC upgrades
- ▶ Data quality shows **good performance**
- ▶ Ready for **2-3 years of physics** data taking

Thanks you for your attention.

# SPARES

# Uncertainty budget

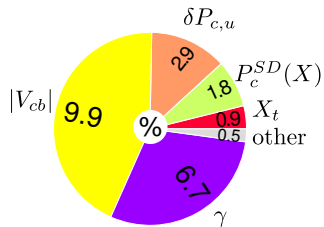

- ▶  $\delta P_{c,u}$  long range contribution to charm
- ▶  $P_c^{SD}$  short range contribution to charm

# Unitarity Triangles

