

Spectral distortions in the cosmic microwave background polarization

Sébastien Renaux-Petel

IAP

Journées Nationales PNCG 2014
LPNHE Paris, 25.11.2014

Outline

1. Spectral distortions

2. Our work

arXiv: 1312.4448 (JCAP)

SRP, C. Filder (Portsmouth), C. Pitrou (IAP), G. Pettinari (Sussex)

Cosmic Microwave Background temperature fluctuations

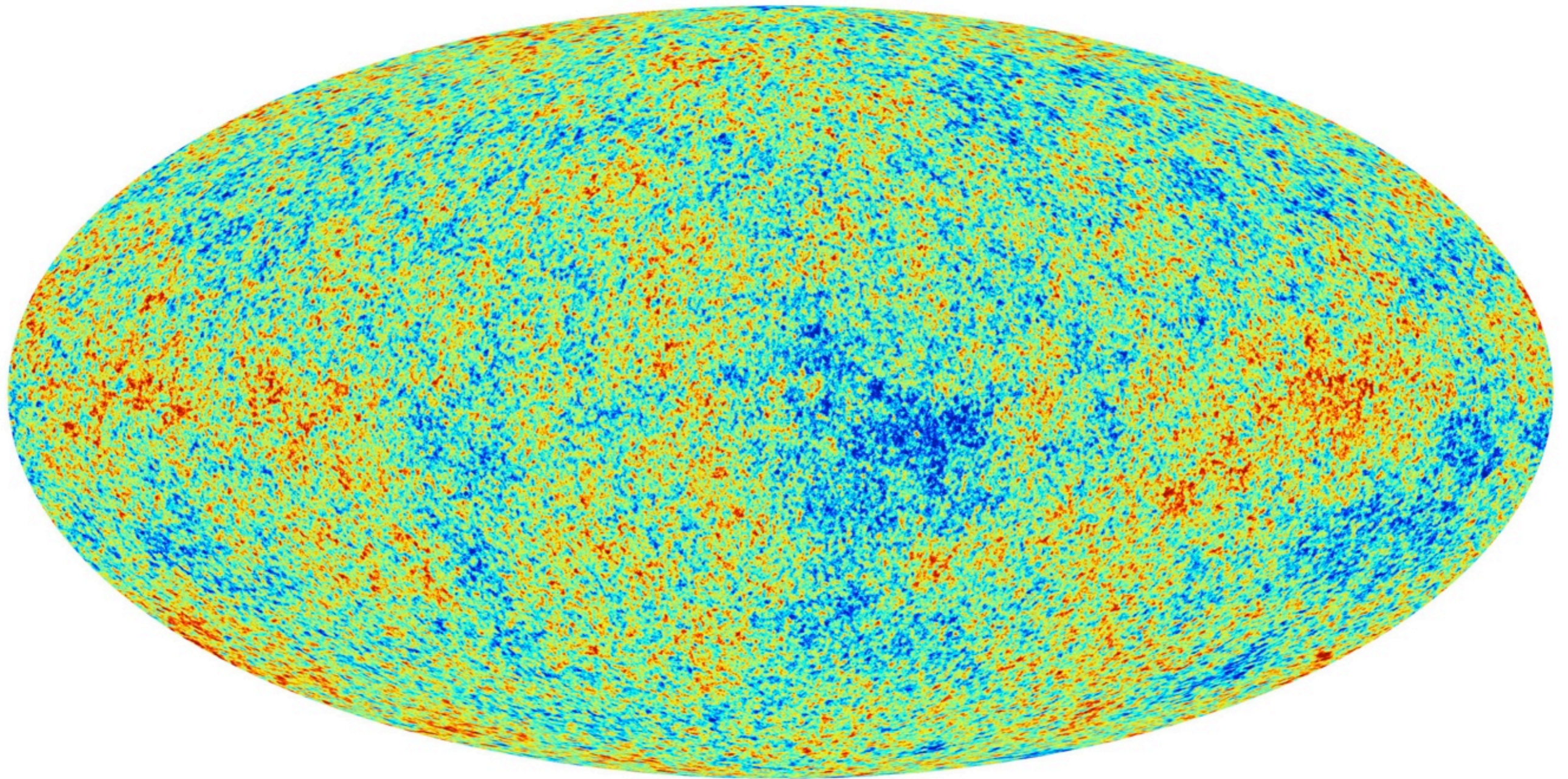

Planck all sky map

Cosmic Microwave Background temperature fluctuations

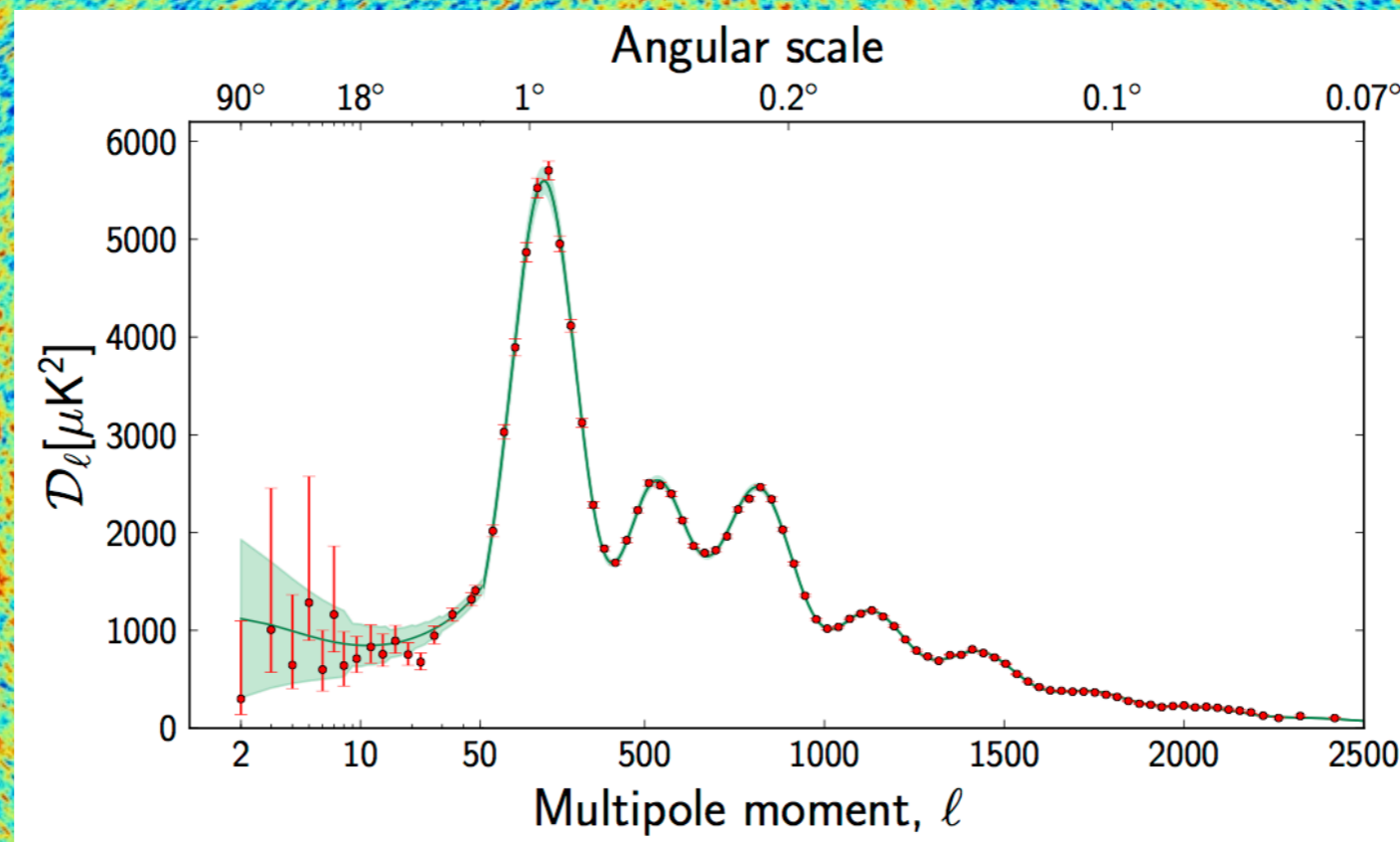

Planck all sky map

Cosmic Microwave Background temperature fluctuations



Planck all sky map

Energy dependence

- Previous picture assumed:

$$I_{BB}(E, \hat{n}) = \frac{2}{e^{\frac{E}{T(\hat{n})}} - 1}$$

- Blackbody (BB) distribution of the CMB intensity with direction-dependent temperature.

- **But:** no full thermodynamic equilibrium throughout the universe history



- The energy dependence **is** more complicated
- The temperature is not enough to characterize the CMB signal. **Its spectral dependence contains another independent piece of information.**

Current spectral distortions constraints

COBE/FIRAS (**F**ar **I**nfra**R**ed **A**bsolute **S**pectrophotometer)

SPECTRUM OF THE COSMIC MICROWAVE BACKGROUND

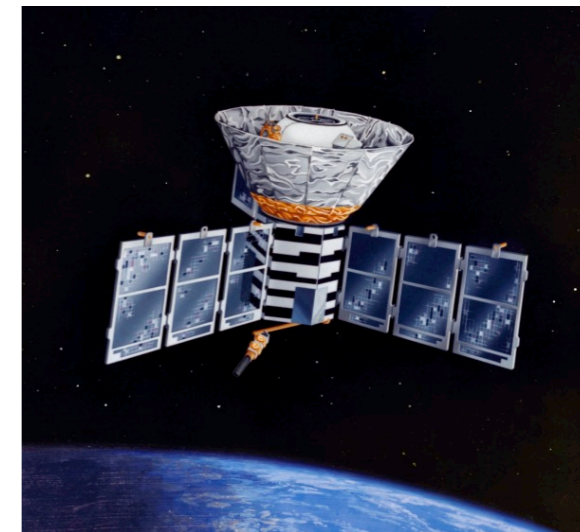
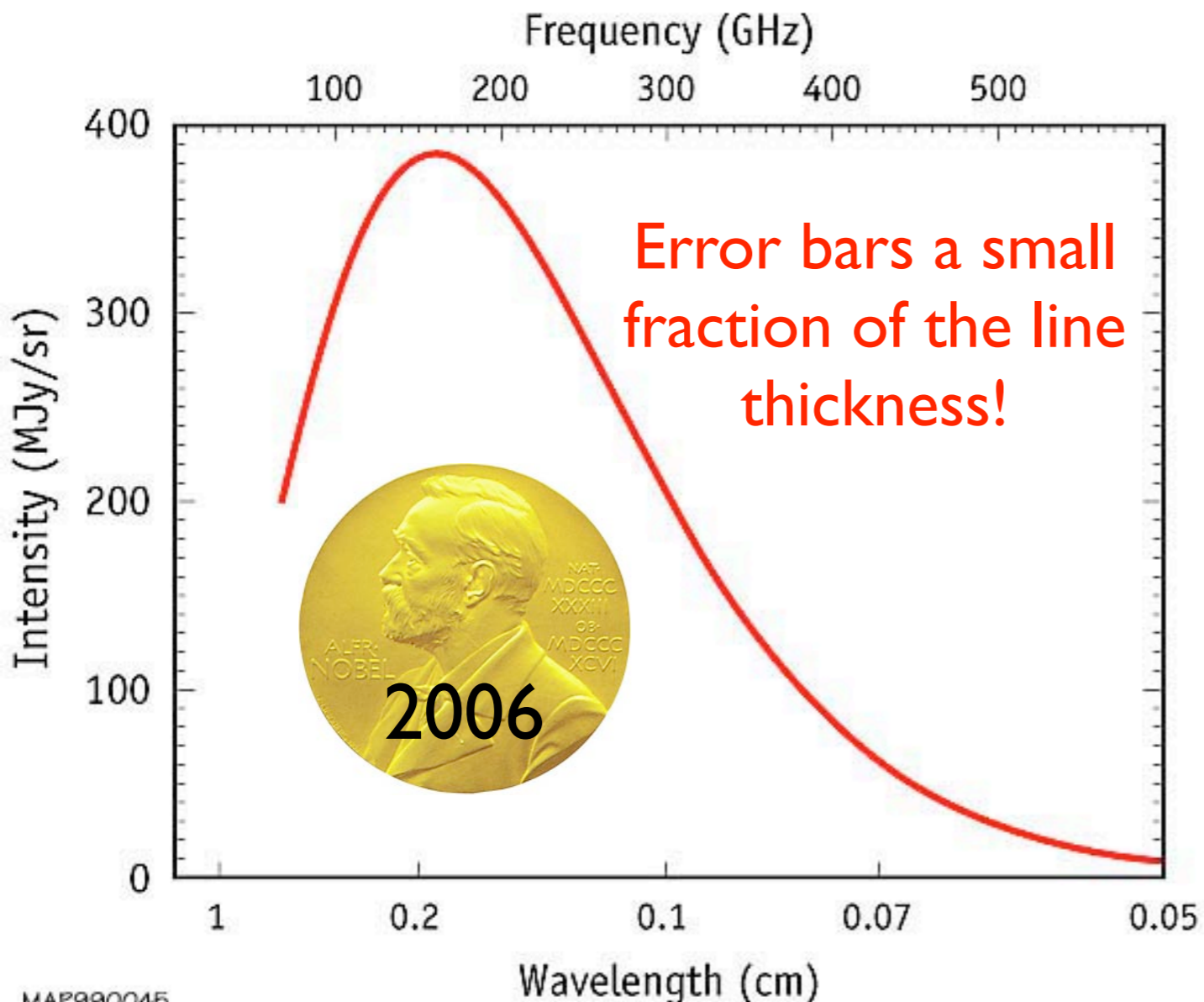

Compton γ -distortion:

$$|\gamma| \leq 1.5 \times 10^{-5}$$

Chemical potential μ -distortion:

$$|\mu| \leq 9 \times 10^{-5}$$

Only very small distortions of the CMB spectrum are allowed

Dramatic improvement in angular resolution and sensitivity in the past decades

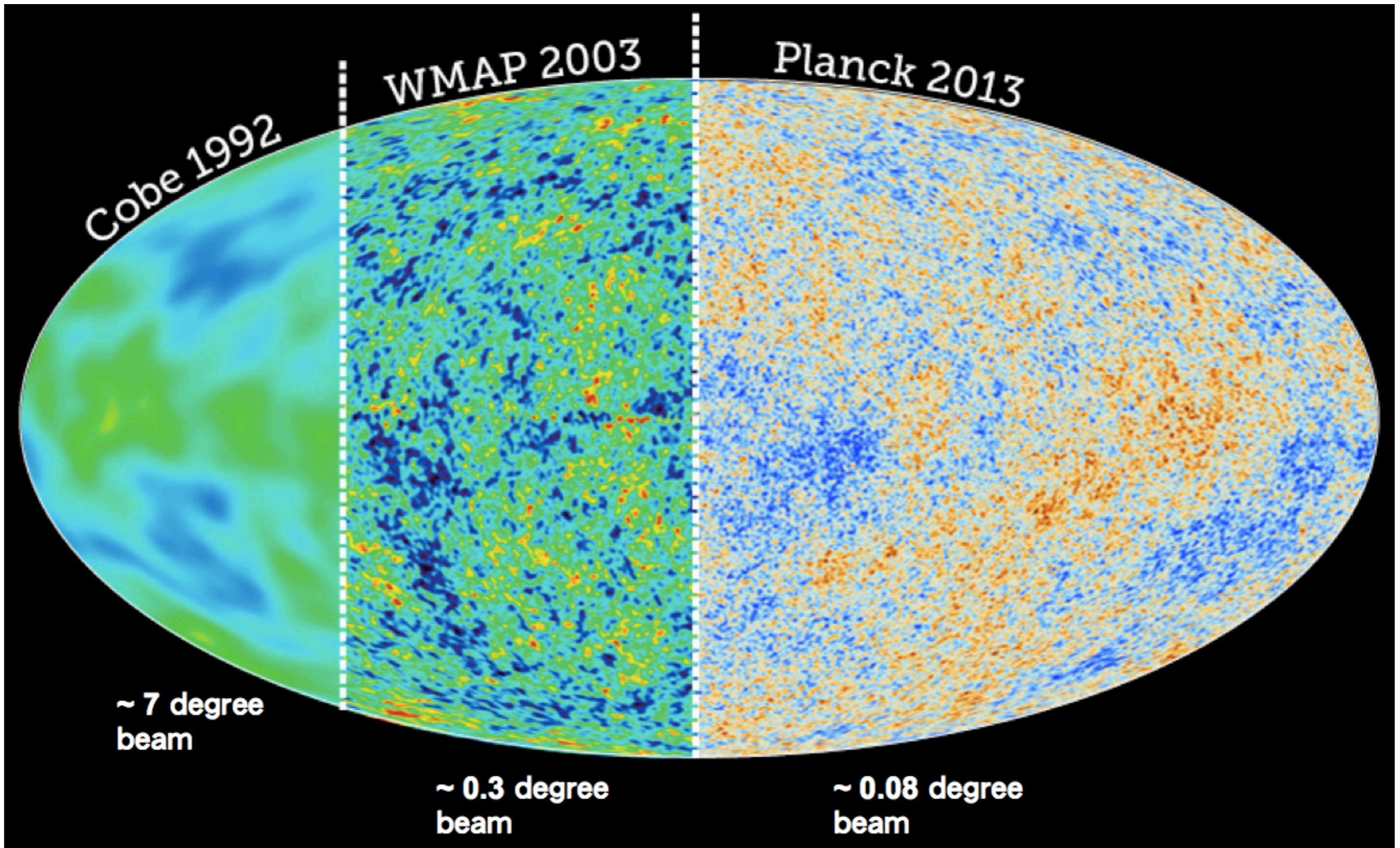

Dramatic improvement in angular resolution and sensitivity in the past decades

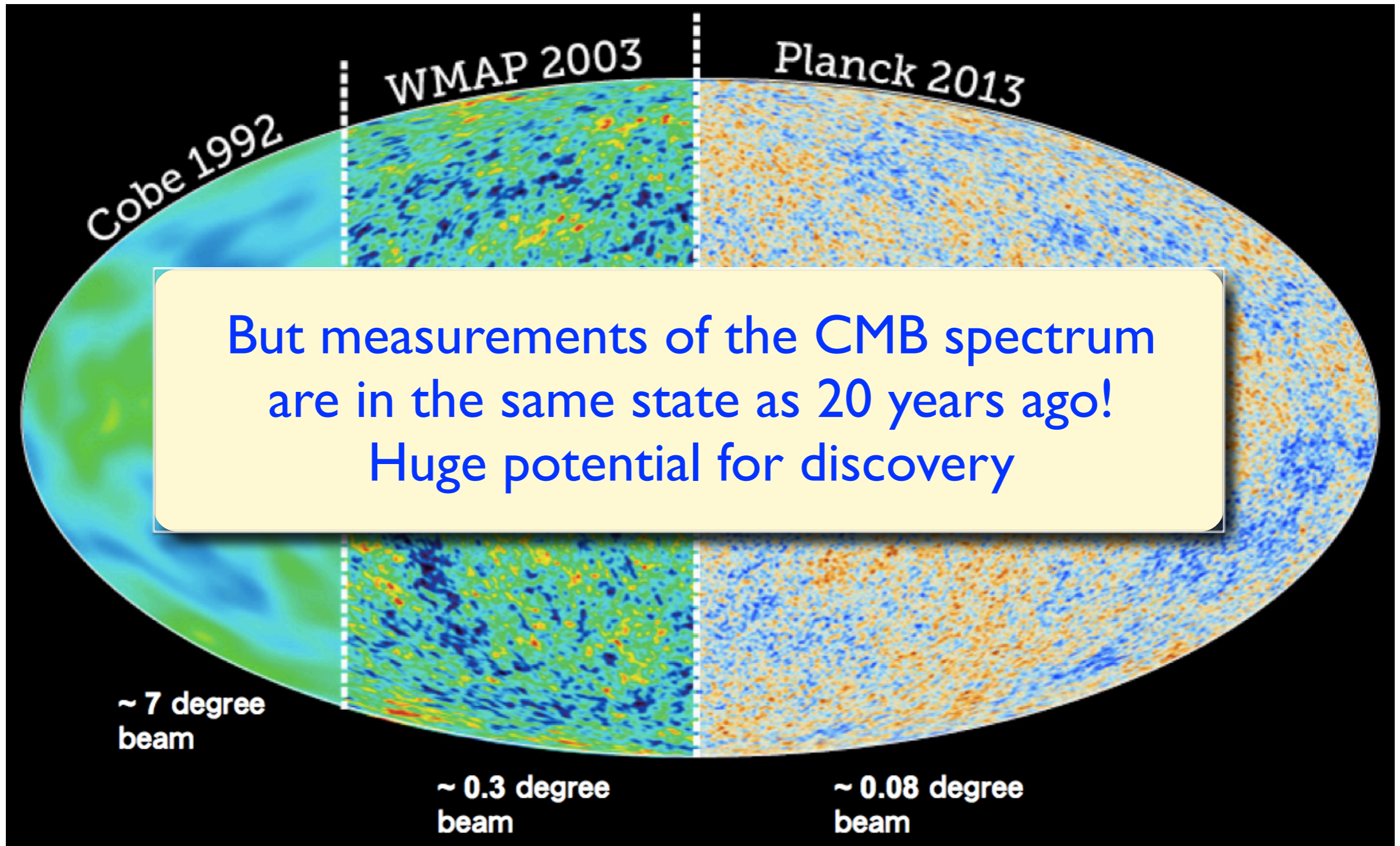

Future expected constraints

PIXIE

arXiv:1105.2044

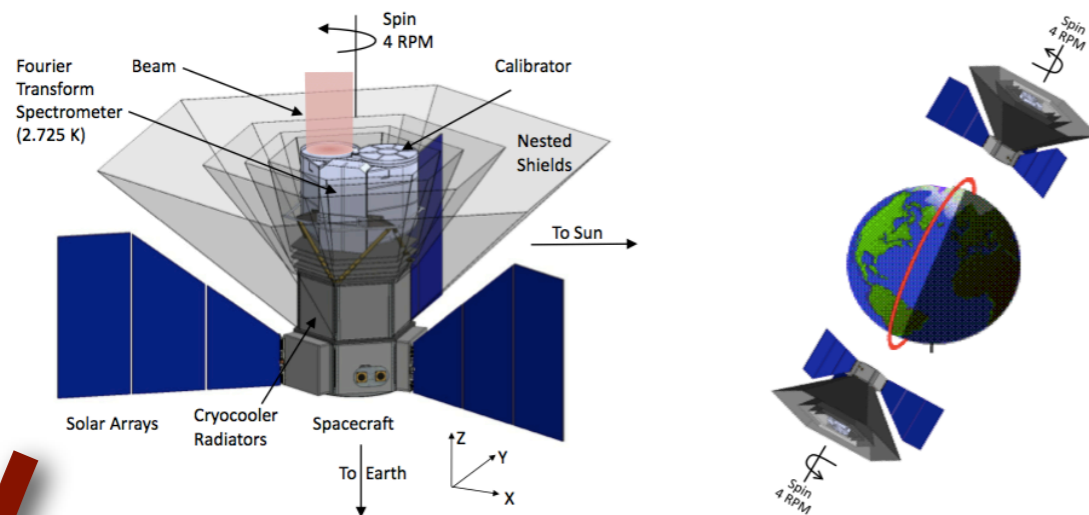

CORe/PRISM?

arXiv:1310.1554

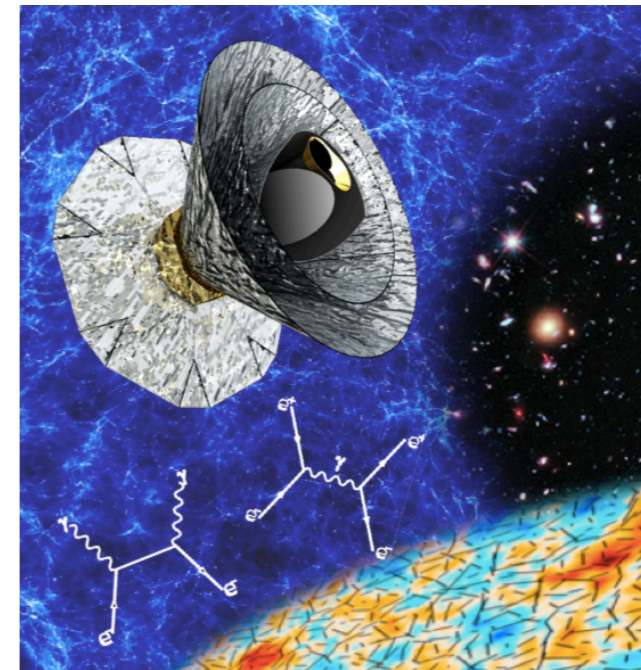

- 400 spectral channels in the frequency range 30 GHz - 6 THz (9 for Planck)
- About 1000 times more sensitive than COBE/FIRAS
- Improved limits on μ and γ by 3 orders of magnitude!

Physical mechanisms that lead to spectral distortions

- Energy injection in the primordial plasma at $z < \text{few} \times 10^6$
- Heating by decaying or annihilating relic particles
- Dissipation of primordial acoustic waves (window into small scale power spectrum)
- Cosmological recombination
- SZ effect from galaxy clusters, effects of reionization ...

Les Houches lecture notes,
Chluba 13

Lots of effects **within the reach of future experiments**

The field of CMB spectral distortions is observationally and theoretically very promising.

Our work

arXiv: 1312.4448 (JCAP)

SRP, C. Filder (Portsmouth), C. Pitrou (IAP), G. Pettinari (Sussex)

- The field of CMB spectral distortions is still in its infancy
- Most work to date concentrate on the CMB intensity, and its monopole
- But future experiments will characterize **the spectrum** of the **CMB anisotropies**, both in **intensity** and **polarization**.
- In 1312.4448, we computed the **unavoidable spectral distortions of the CMB polarization** induced by non-linear effects in the **Compton interactions between CMB photons and the flow of intergalactic electrons** (non-linear kinetic Sunyaev Zel'dovich)

CMB spectral distortions

$$I(E, \hat{n}) = I_{\text{Planck}}(E; T(\hat{n})) + y(\hat{n}) \times \left(\begin{array}{c} \text{Other} \\ \text{spectral dependence} \end{array} \right)$$

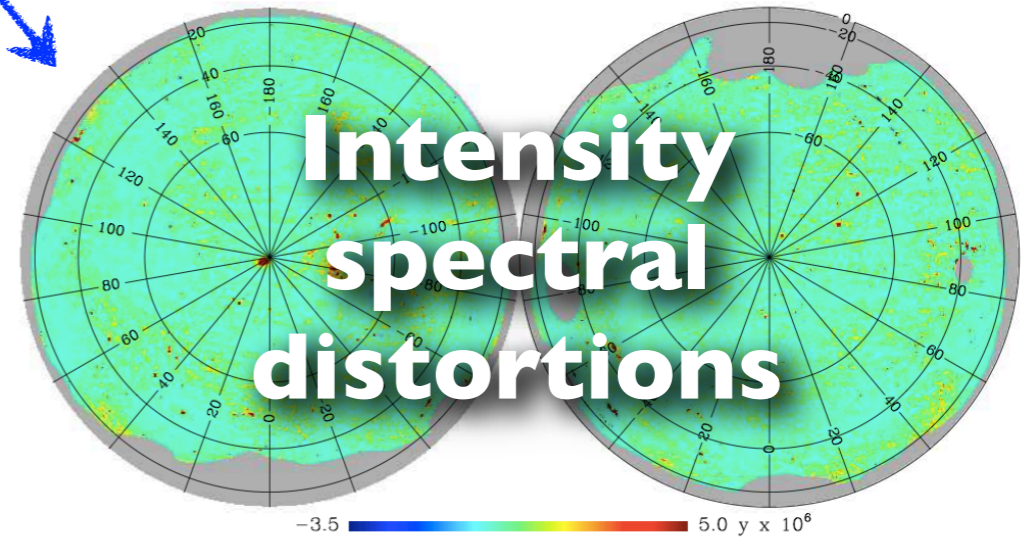
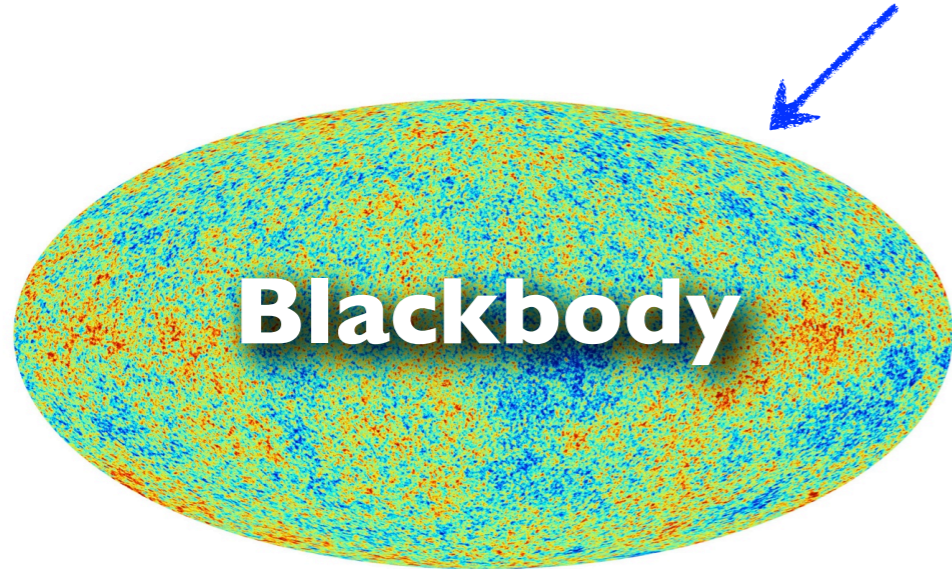

Planck I303.508I

$$P_{\mu\nu}(E, \hat{n}) = \text{Standard polarization} + ?$$

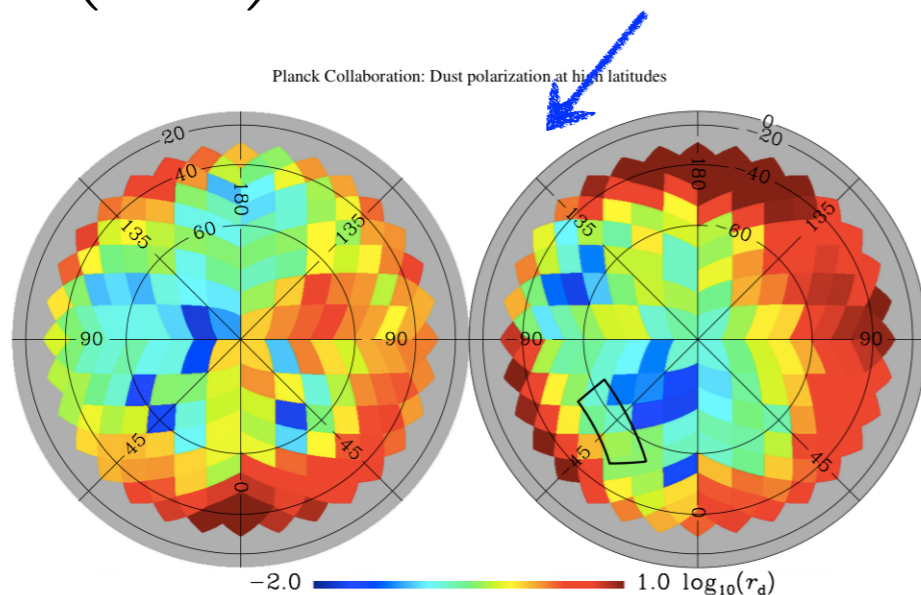

Planck I409.5738

Polarization spectral distortions

Intensity y -type distortions

$$I\left(E, \hat{n}\right) = I_{\text{BB}}\left(\frac{E}{T(\hat{n})}\right) + y(\hat{n}) \mathcal{D}_E^2 I_{\text{BB}}\left(\frac{E}{T(\hat{n})}\right)$$

Energy

**direction of photon
propagation**

$$\mathcal{D}_E^2 \equiv E^{-3} \frac{\partial}{\partial \ln E} \left(E^3 \frac{\partial}{\partial \ln E} \right) = \frac{\partial^2}{\partial \ln E^2} + 3 \frac{\partial}{\partial \ln E}$$

Number density
of photons:

$$n \propto \int I E^3 d \ln E$$



T: temperature of a
blackbody that would have
the same number density

see Pitrou, Stebbins, I402.0968

Polarization γ -type distortions

$$P_{\mu\nu}(E, \hat{n}) = -\mathcal{P}_{\mu\nu}(\hat{n}) \frac{\partial}{\partial \ln E} I_{\text{BB}} \left(\frac{E}{T(\hat{n})} \right) + y_{\mu\nu}(\hat{n}) \mathcal{D}_E^2 I_{\text{BB}} \left(\frac{E}{T(\hat{n})} \right)$$

Polarization tensor

'Standard polarization'

Polarization distortion

E and B modes

E^Y and B^Y modes

- Similarly to γ , Compton scattering generates a non-zero polarization distortion only **beyond first-order perturbation theory**



- Need for polarized Boltzmann equation at second order, with proper spectral dependence decomposition

Brightness signals

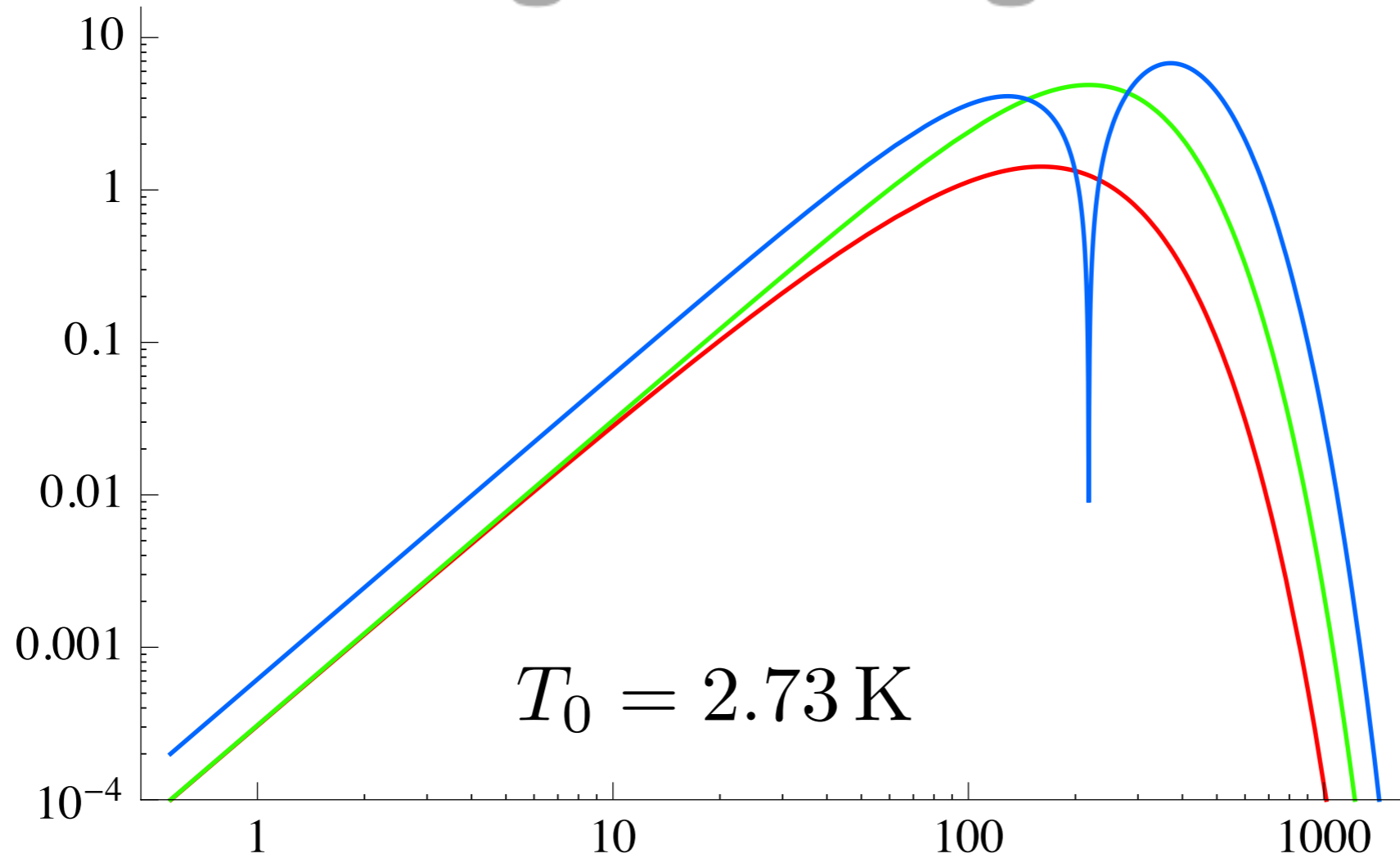

- Blackbody spectrum**

$\text{GHz} \left(\frac{E}{T_0}\right)^3 I_{\text{BB}}(E/T_0)$
- Standard polarization**

$\left(\frac{E}{T_0}\right)^3 \frac{\partial I_{\text{BB}}(E/T_0)}{\partial \ln E}$
- Polarization distortion**

$\left(\frac{E}{T_0}\right)^3 \mathcal{D}_E^2 I_{\text{BB}}(E/T_0)$

Boltzmann equation for polarization distortion

Boltzmann equation:

$$y'_{ij} + n^l \partial_l y_{ij} = \tau' (-y_{ij} + C_{ij}^y)$$

Thomson interaction rate $\tau' \equiv a \bar{n}_e \sigma_T$

Line of sight formal solution

$$y_{ij}(\eta_0, k_i, n^i) = \int^{\eta_0} d\eta \tau' e^{-\tau} e^{-i k_i n^i (\eta_0 - \eta)} C_{ij}^y(\eta, k_i, n^i)$$

$$g(\eta) = \tau' e^{-\tau} \quad \text{Visibility function}$$

Non-linear kSZ effect

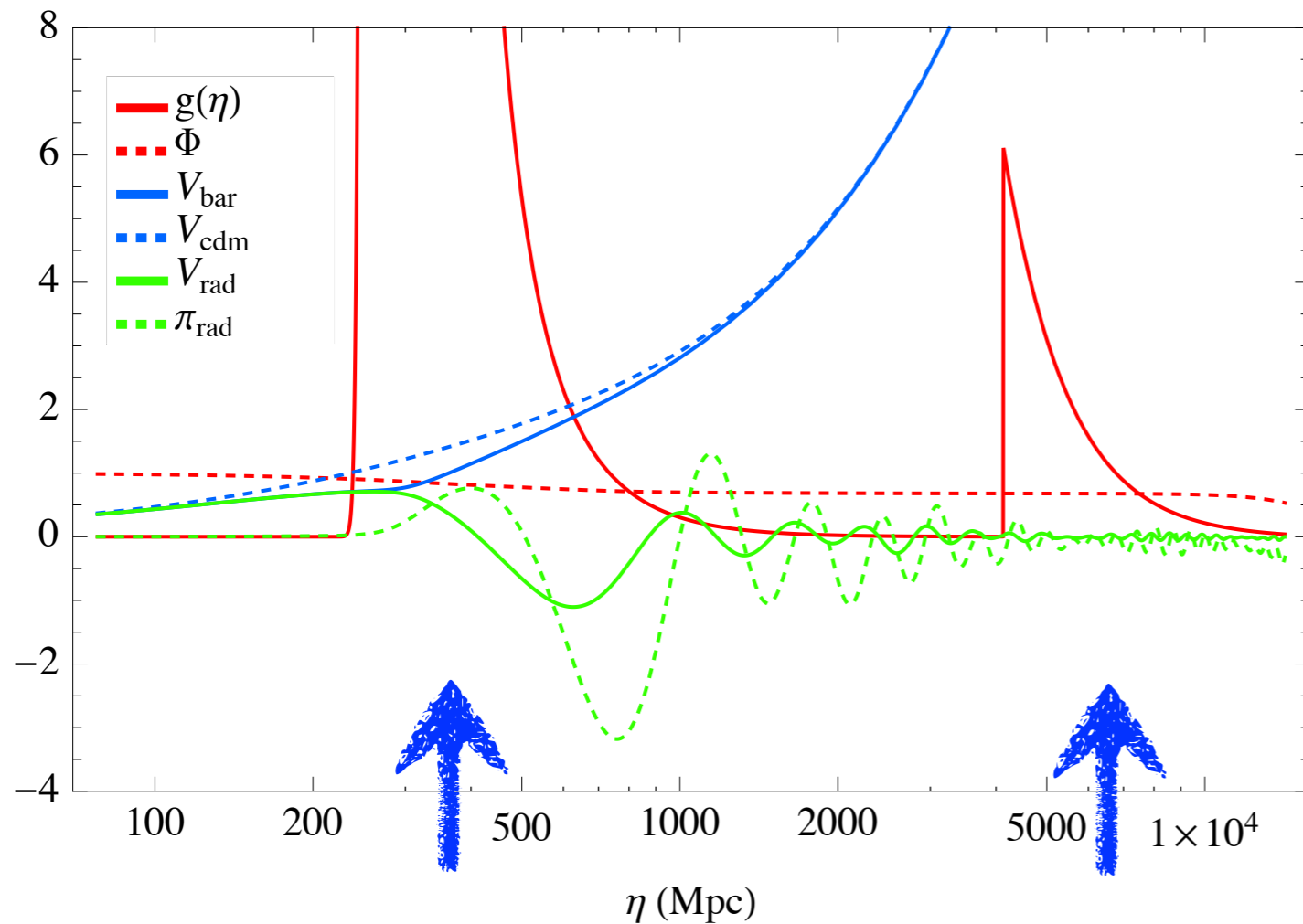

Recombination

Reionization



Main signal originates from reionization ($z < 15$)

Leading-order collision term:

$$C_{ij}^{y(\text{L.O.})} = -\frac{1}{10} [v_i v_j]^{\text{TT}}$$

Difference between the first-order electron and photon velocities.
Grows after recombination.

Numerical results

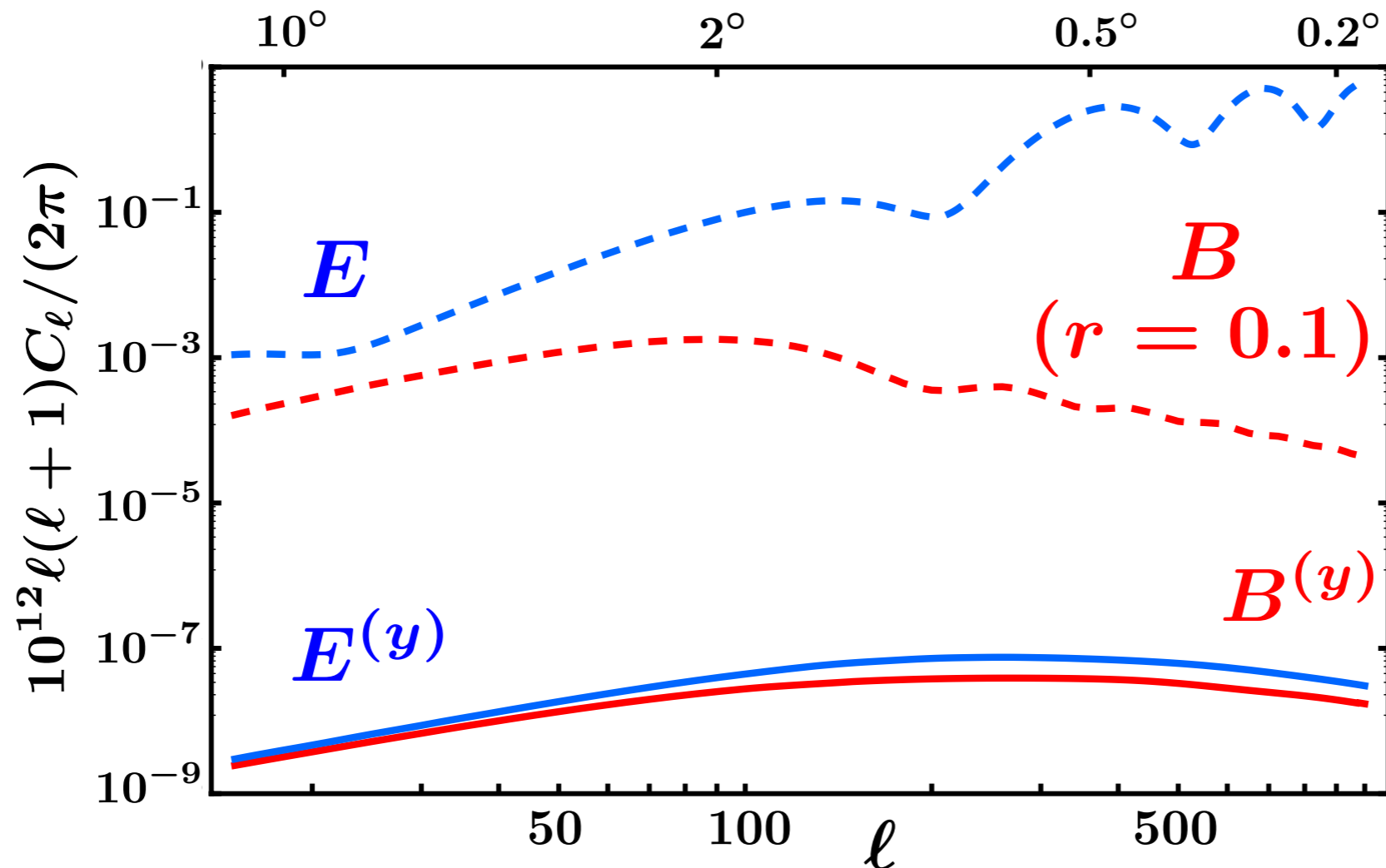

SONG, Pettinari,
Fidler et al,
I302.0832

- E^y and B^y modes of similar magnitude (same sources)
- Smooth spectra (no acoustic oscillation structure)
- Naive suppression for a second-order effect mitigated by the growth of the electron velocity

Non-linear kSZ effect from clusters

- The same effect is discussed in the context of [galaxy clusters](#)

[astro-ph/0307293](#), [astro-ph/0208511](#) ...

- Our signal is **one order of magnitude larger**

- Simple understanding:

- on angular scales at which clusters are unresolved, $\ell \lesssim 500$, linear description is enough to model the electron number density

- **additional contribution pre-formation of clusters**, for $2 \lesssim z \lesssim 12$, when the visibility function is the largest.

Contribution(z) to $\ell(\ell + 1)C_{\ell}^{E^y}_{\text{Limber}}$

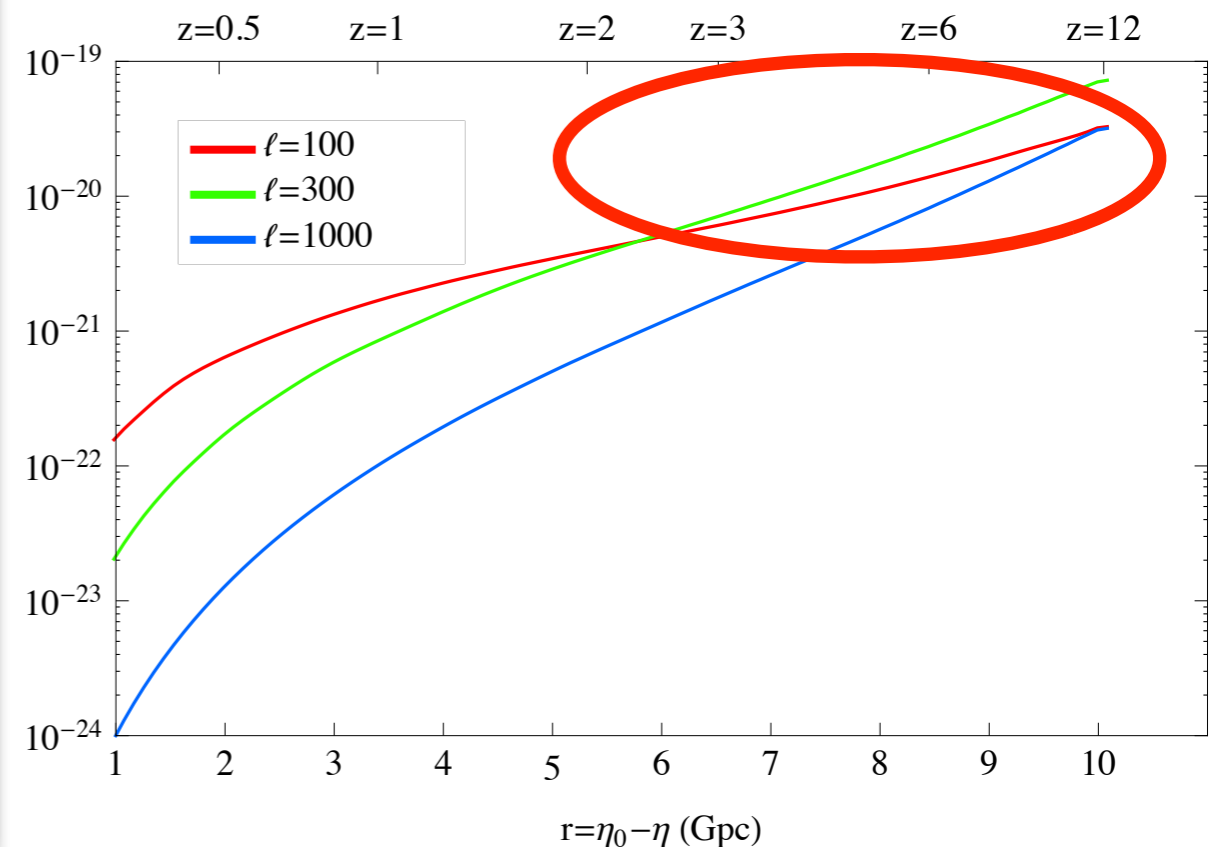

Improving the detectability with cross-correlations

- **Standard polarization** has a similar contribution

$$\mathcal{P}_{\mu\nu} = (\mathcal{P}_{\mu\nu})_{\text{linear}} + 4 (y_{\mu\nu})_{kSZ} \quad \longrightarrow \quad \begin{aligned} \langle E^{\text{st}} E^{y*} \rangle &= 4 \langle E^y E^{y*} \rangle \\ \langle B^{\text{st}} B^{y*} \rangle &= 4 \langle B^y B^{y*} \rangle \end{aligned}$$

- Correlation with the **y-type intensity distortion** (sourced by tSZ effect + non-linear kSZ effect)

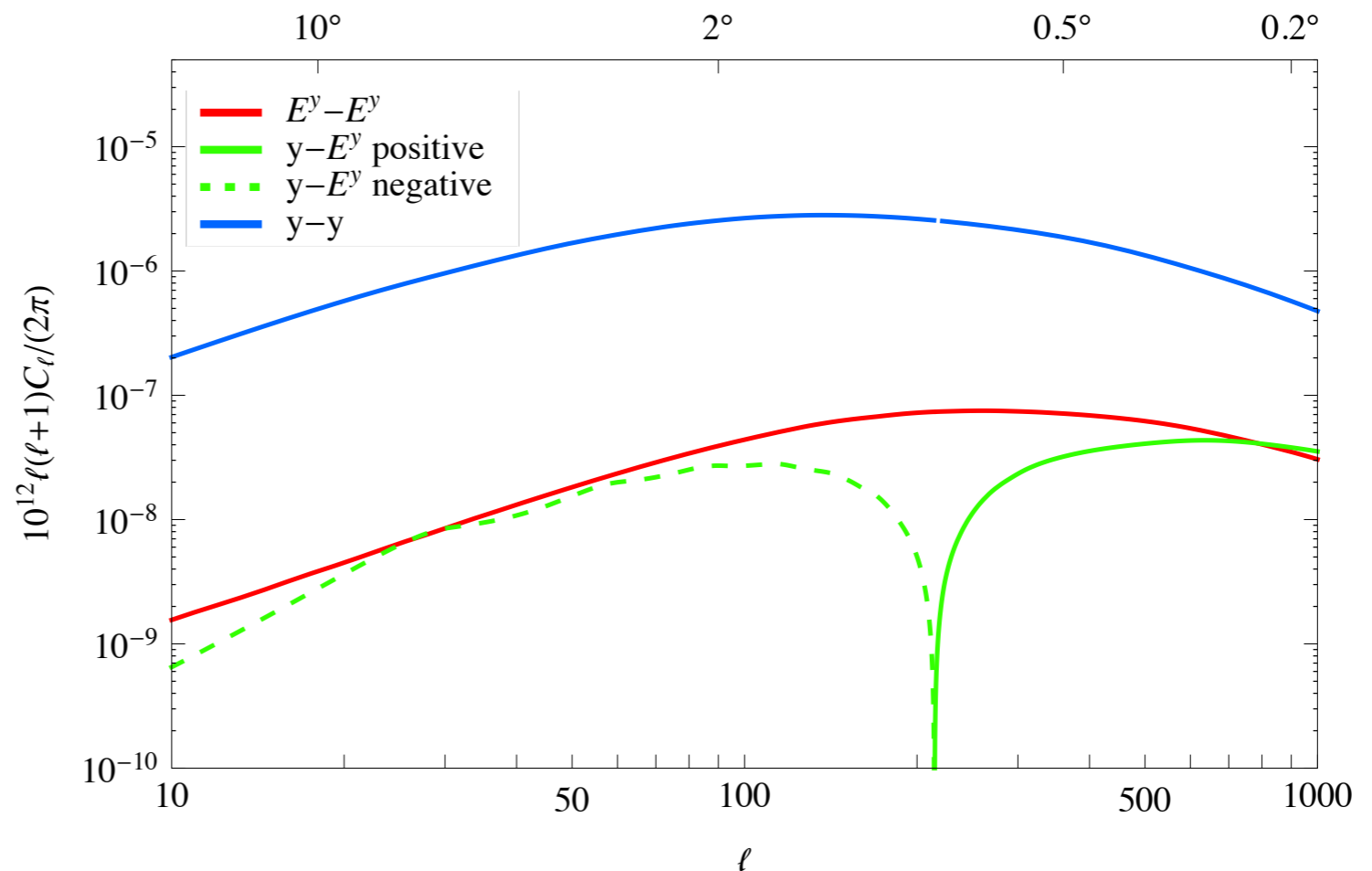

Effects of an extended period of reionization

- Reionization history is unknown but is necessarily more complicated than the simple scenario of instantaneous reionization.



$$x_e(z) \equiv \frac{n_e(z)}{n_H(z)} = \frac{1}{2} \left\{ 1 + \tanh \left[\frac{(1+z_r)^{3/2} - (1+z)^{3/2}}{\Delta} \right] \right\}$$

built such that total optical depth independent of Delta.

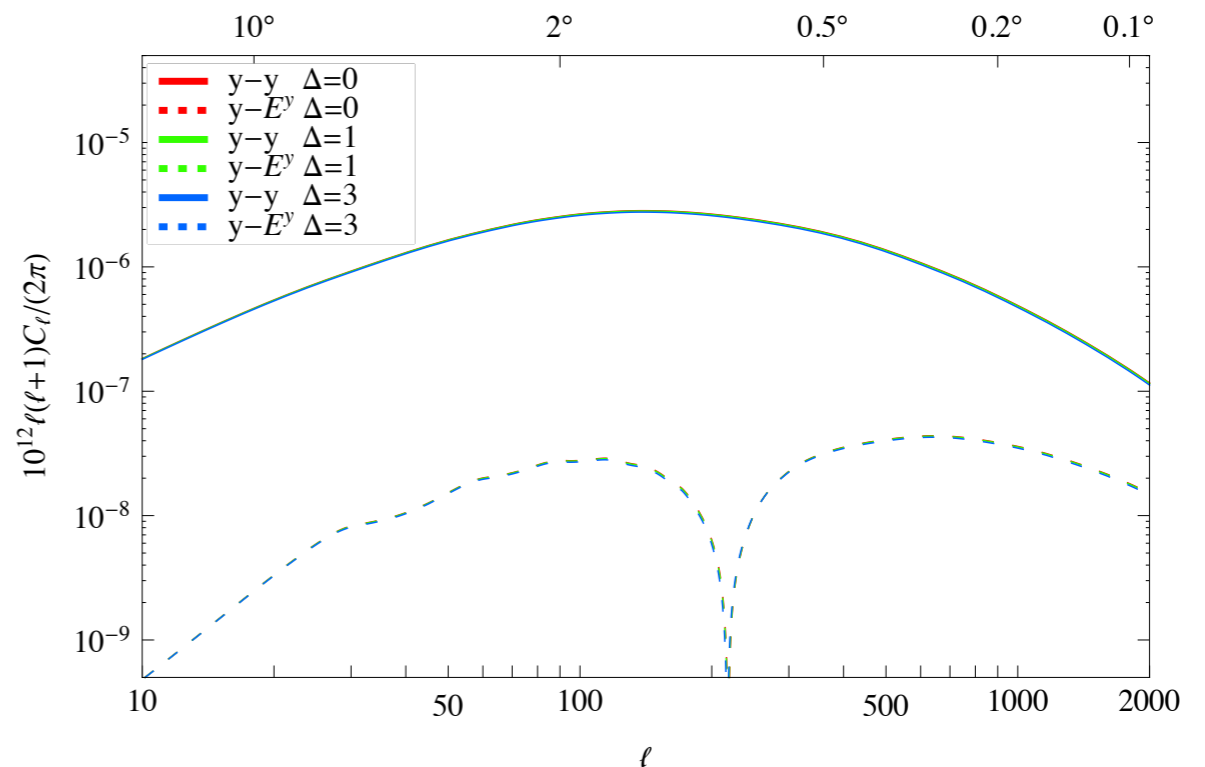
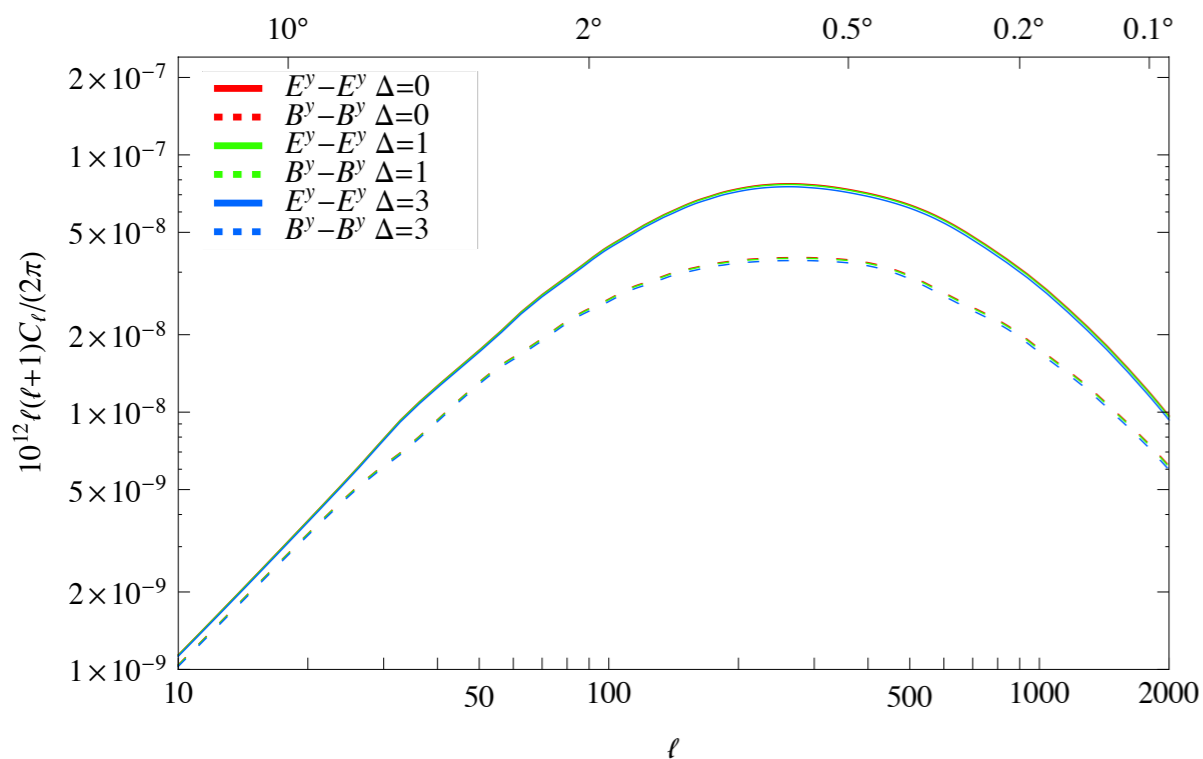

Effects of an extended period of reionization

- Reionization history is unknown but is necessarily more complicated than the simple scenario of instantaneous reionization.



$$x_e(z) \equiv \frac{n_e(z)}{n_H(z)} = \frac{1}{2} \left\{ 1 + \tanh \left[\frac{(1+z_r)^{3/2} - (1+z)^{3/2}}{\Delta} \right] \right\}$$

built such that total optical depth independent of Delta.

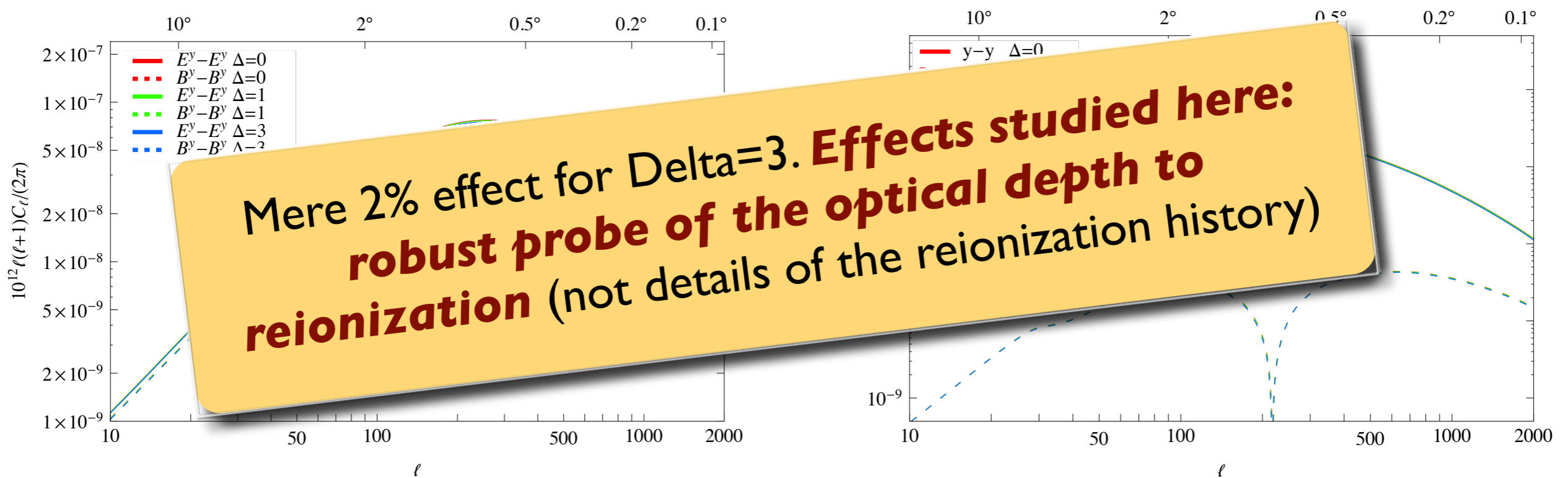

Conclusions

- CMB spectral distortions: **new promising observational window in cosmology**
- Probe of the thermal history of the universe, inflation, dark matter, reionization...
- It should be studied **at the level of the anisotropies of the intensity and polarization**
- First step in this direction: unavoidable contribution to **diffuse polarization distortion generated by non-linear kSZ effect from reionization. Larger than contribution from clusters.**