



Adam Maj (IFJ PAN Kraków)
for the PARIS collaboration

The PARIS Array - Status of the Project and Perspectives



paris.ifj.edu.pl

4-5-6th October, 2005 „Future prospects for high resolution gamma spectroscopy at GANIL” - Convenors : Bob Wadsworth and Wolfram Korten

WG „Collective modes in continuum” – convenors: Silvia Leoni & Adam Maj

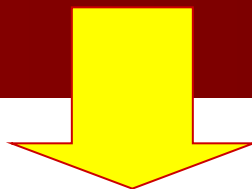

GANIL

SAC open session

October 19th, 2006

Letter of Intent for SPIRAL 2

Title: High-energy γ -rays as a probe of hot nuclei and reaction mechanisms

Spokesperson(s) (max. 3 names, laboratory, e-mail - please underline among them one corresponding spokesperson):

Adam Maj, IFJ PAN Krakow, Adam.Maj@ifj.edu.pl

Jean-Antoine Scarpaci, IPN Orsay, scarpaci@ipno.in2p3.fr (E)

David Jenkins, University of York (UK), dj4@york.ac.uk

GANIL contact person

Jean-Pierre Wieleczko, GANIL, wieleczko@ganil.fr

Aim:
to design and build
efficient gamma calorimeter
PARIS

COLLABORATION



PARIS Management board

A. Maj - project spokesman;

D.G. Jenkins, J.P. Wieleczo, J.A. Scarpaci - deputies

PARIS Steering (Advisory) Committee

F. Azaiez (F) -chairman, D. Balabanski (BG), W. Catford (UK), D. Chakrabarty (India), Z. Dombardi (H), S. Courtin (F), J. Gerl (D), D. Jenkins (UK) - deputy chairman, S. Leoni (I), A. Maj (PL), J.A. Scarpaci (F), Ch. Schmidt (F), J.P. Wieleczo (F)

Active working groups

1. Simulations (O. Stezowski et al.)
2. PARIS mechanical design scenarios (S. Courtin, D. Jenkins et al.)
3. Physics cases and theory background (Ch. Schmitt et al.)
4. Detectors (O. Dorvaux et al.)
5. Electronics (P. Bednarczyk et al.)
6. PARIS-GASPARD synergy (J.A. Scarpaci et al.)
7. Financial issues (J.P. Wieleczo et al.)
8. PARIS in FP7 projects (A. Maj, F. Azaiez et al.)

J. Pouthas – PARIS liaison to SPIRAL2 project management

Members of the Collaboration :

Give the list of participating institutions and names of collaborators.

IFJ PAN Kraków (Poland): P. Bednarczyk, M. Kmiecik, B. Fornal, J. Grębosz, A. Maj, W. Męczyński, K. Mazurek, S. Myalski, J. Styczeń, M. Ziębliński, M. Ciemała, A. Czermak, R. Wolski, M. Chełstowska
IPN Orsay (France): F. Azaiez, J.A. Scarpaci, S. Franchoo, I. Stefan, I. Matea
CSNSM Orsay (France): G. Georgiev, R. Lozeva
University of York (UK): D.G. Jenkins, M.A. Bentley, B.R. Fulton, R. Wadsworth, O. Roberts
University of Edinburgh (UK): D. Watts
IPN Lyon (France): Ch. Schmitt, O. Stezowski, N. Redon
IPHC Strasbourg (France): O. Dorvaux, S. Courtin, C. Beck, D. Curien, B. Gall, F. Haas, D. Lebhertz, M. Rousseau, M.-D. Salsac, L. Stuttgé, J. Dudek
GANIL Caen (France): J.P. Wieleczko, S. Grevy, A. Chbihi, G. Verde, J. Frankland, M. Ploszajczak, A. Navin, G. De France, M. Lewitowicz
LPC-ENSI Caen (France): O. Lopez, E. Vient
Warsaw University (Poland): M. Kicinska-Habior, J. Srebrny, M. Palacz, P. Napiorkowski
IPJ Swierk, Otwock (Poland): M. Moszynski
BARC Mumbai (India): D.R. Chakrabarty, V.M. Datar, S. Kumar, E.T. Mirgule, A. Mitra, P.C. Rout
TIFR Mumbai (India): I. Mazumdar, V. Nanal, R.G. Pillay, G. Anil Kumar
University of Delhi, New Delhi (India): S.K. Mandal
University of Surrey, Guildford (UK): Z. Podolyak, P.R. Regan, S. Pietri, P. Stevenson
GSI Darmstadt (Germany): M. Górska, J. Gerl
University of Oslo (Norway): S. Siem
Oak Ridge (US): N. Schunck
ATOMKI Debrecen (Hungary): Z. Dombradi, D. Sohler, A. Krasznahorkay, G. Kalinka, J. Gal, J. Molnar
INRNE, Bulgarian Academy of Sciences, Sofia (Bulgaria): D. Balabanski,
University of Sofia (Bulgaria): S. Lalkovski, K. Gladnishki, P. Detistov
NBI Copenhagen (Denmark): B. Herskind, G. Sletten
UMCS Lublin (Poland): K. Pomorski
HMI Berlin (Germany): H.J. Krappe
LBNL, Berkeley, CA (US): M.-A. Deleplanque, F. Stephens, I.-Y. Lee, P. Fallon
iThemba LABS (RSA): R. Bark, P. Papka, J. Lawrie
DSM/Dapnia CEA Saclay (France): C. Simenel
INFN-LNS, Catania (Italy): D. Santonocito
INP, NCSR "Demokritos", Athens (Greece): S. Harissopulos, A. Lagoyannis, T. Konstantinopoulos
Istanbul University, Instambul (Turkey): M.N. Erduran, M.Bostan, A. Tutay, M. Yalcinkaya,
I. Yigitoglu, E. Ince, E. Sahin
Nigde University, Nigde (Turkey): S. Erturk
Erciyes University, Kayseri (Turkey): I. Boztosun
Ankara University, Ankara (Turkey): A. Ataç-Nyberg
Kocaeli University, Kocaeli (Turkey): T. Güray
Flerov Laboratory of Nuclear Reactions, JINR, Dubna (Russia): A. Fomichev, S. Krupko, V. Gorshkov.
Uppsala University, Uppsala (Sweden): H. Mach
KVI, Groningen (The Netherlands): M. Harakeh
INFN Milano (Italy): S. Brambilla, F. Camera, S. Leoni, O. Wieland.
LPSC Grenoble (France): G. Simpson
INFN Napoli (Italy): D. Pierroutsakou
STFC Daresbury (UK): J. Simpson, J. Strachan, M. Labiche
Nuclear Physics Group, The University of Manchester (UK): A. Smith
RIKEN Tokyo (JP): P. Doornenbal

**40 institutions from 17 countries
≈ 100 physicists, engineers and
PhD students**

PHYSICS CASE

* - flagship

a) Jacobi and Poincare shape transitions (+AGATA)

*

$^{130-142}\text{Ba}$, $^{116-120}\text{Cd}$, $^{88-98}\text{Mo}$, ^{71}Zn

(A. Maj, J. Dudek, K. Mazurek et al.)

A

b) Studies of shape phase diagrams of hot nuclei – GDR differential methods

$^{186-193}\text{Os}$, $^{190-197}\text{Pt}$

(I. Mazumdar, A. Maj et al.)

c) Hot GDR studies in neutron rich nuclei *

(D.R. Chakrabarty, M. Kmiecik et al.)

d) Isospin mixing at finite temperature

^{68}Se , ^{80}Zr , ^{84}Mo , ^{96}Cd , ^{112}Ba

(M. Kicińska-Habior et al.)

e) Onset of the multifragmentation and the GDR (+FAZIA)

$^{120}<A<140$, $^{180}<A<200$

(J.P. Wieleczko, D. Santonocito et al.)

A

f) Reaction dynamics by means of γ -ray measurements

$^{214-222}\text{Ra}$, $^{118-226}\text{Th}$, $^{229-234}\text{U}$

(Ch. Schmitt, O. Dorvaux et al.)

A

g) Heavy ion radiative capture *

^{24}Mg , ^{28}Si

(S. Courty, D.G. Jenkins et al.)

h) Multiple Coulex of SD bands

$^{36}<A<50$

(P. Napiorkowski, F. Azaiez, A. Maj et al.)

A

i) Relativistic Coulex

(case mainly for FAIR and RIKEN)

$^{40}<A<90$

(P. Bednarczyk et al.)

A

j) Nuclear astrophysics (p,γ)

e.g. ^{90}Zr

(S. Harissopulos et al.)

k) Shell structure at intermediate energies (SISSI/LISE)

$^{20}<A<40$

(Z. Dombradi et al.)

A

l) Shell structure at low energies (separator part of S³) *

$^{30}<A<150$

(F. Azaiez, I. Stefan, B. Fornal et al.)

A

m) PDR studied with GASPARD+PARIS

D. Beaumel et al.

A

n) PDR in proton-rich nuclei with NEDA+PARIS

G. De Angelis et al.

A

o) Onset of chaotic regime: PARIS+AGATA

S. Leoni et al.

A

Physics Case	Recoil mass	v/c [%]	E_γ range [MeV]	$\Delta E_\gamma/E_\gamma$ [%]	$\Delta E_{\text{sum}}/E_{\text{sum}}$ [%]	ΔM_γ	Ω coverage
Jacobi transition	40-150	<10	0.1-30	4	<5	4	2π - 4π
Shape Phase Diagram	160-180	<10	0.1-30	6	<5	4	2π - 4π
Hot GDR in n-rich nuclei	120-140	<11	0.1-30	6	<8	4	2π - 4π
Isospin mixing	60-100	<7	5-30	6	-	-	4π
Reaction dynamics	160-220	<7	0.1-25	6-8	<8	4	2π
Collectivity vs. multi-fragmentation	120-200	<8	5-30	5	-	-	2π
Radiative capture	20-30	<3	1-30	<4	5	-	4π
Multiple Coulex	40-60	<7	2-6	5	-	-	2π
Astrophysics	16-90	0.1	0.1-6	6	5	-	4π
Shell structure at intermediate energies (SISSI/LISE)	16-40	20-40	0.5-4	3	-	-	3π
Shell structure at low energies (separator part of S^3)	30-150	10-15	0.3-3	3	-	-	3π
Relativistic Coulex	40-60	50-60	1-4	4	-	1	Forw 3π

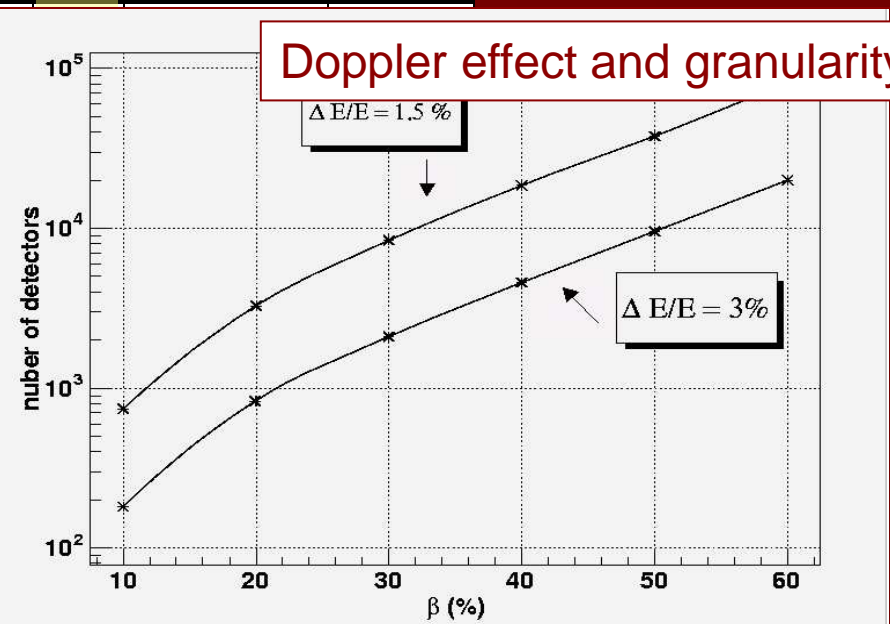
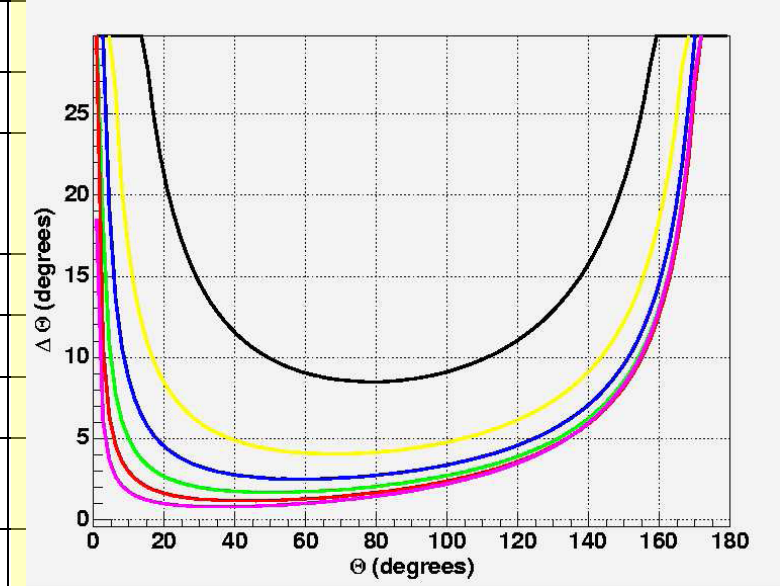

$\langle \beta \rangle \approx 10\%$; $\Delta M/M < 4 \rightarrow$ **Granularity: 200-800**

$\Delta T: < 1$ ns; $\Delta E_\gamma/E_\gamma: < 3\%$; high efficiency up to 15 MeV \rightarrow **LaBr₃ scintillators**

PARIS has to

- be transportable (between different RIs)
- be modular (to be connected with other detectors: AGATA, GASPARD, NEDA, FAZIA, ...)
- have high granulation (multiplicity measurement, Doppler correction,...)
- have very high efficiency for high-energy γ -rays
- have good timing resolution (<500 ps)
- have possibly good energy resolution

Why LaBr₃?

large light output (>60000 ph/MeV)
high efficiency (>60% up to 10 MeV)

→spectroscopy far from stability

energy resolution (3% at 662 keV, 0.6% at 18 MeV)

→spectroscopy far from stability

time resolution (~250 ps)

→discrimination against neutrons

fast light pulse decay (~16 ns)

→high counting rate capability

very good temperature stability, worldwide interest, also in medical sector

Milan group: Source and 3"x3" crystal

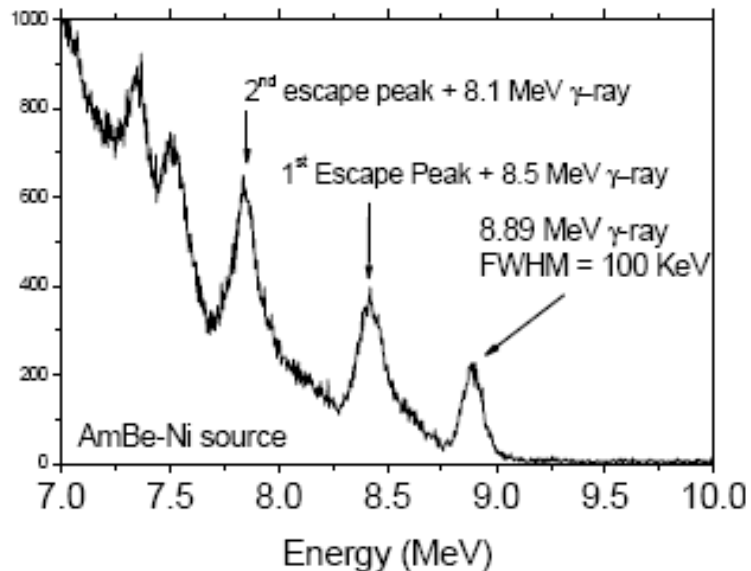

Debrecen-Sofia-Orsay-Krakow group:
(p, γ) reaction and 2"x2" crystal

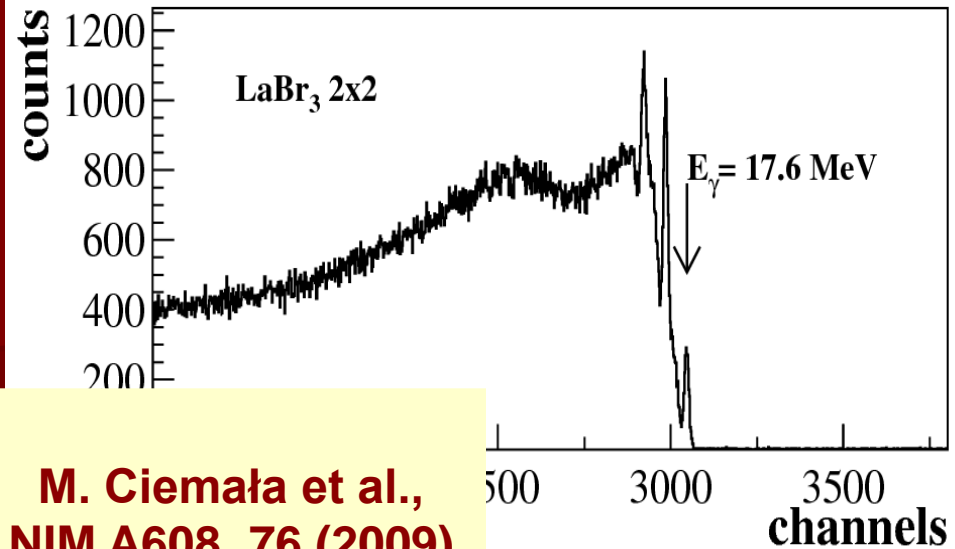

M. Ciemala et al.,
NIM A608, 76 (2009)



PARIS desing concepts:

**Design and build high efficiency detector
consisting of 2 shells (*or 1 shell*)
for medium resolution spectroscopy
and calorimetry of γ -rays in large energy range**

Inner (hemi-)sphere, **highly granular**, will be made of new crystals ($\text{LaBr}_3(\text{Ce})$).
The **inner-sphere** will be used as a **multiplicity filter of high resolution, sum-energy detector (calorimeter), detector for the gamma-transition up 10 MeV with medium energy resolution**. It will serve also for fast timing application.

Outer (hemi-)sphere, with **high volume detectors**, could be made from conventional crystals (BaF_2 or NaI), or using existing detectors (Chateau de Crystal or HECTOR).
The **outer-sphere** will measure **high-energy photons** or serve as **an active shield** for the inner one.

BASIC SIMULATIONS

PARIS GEANT4 software – **O. Stezowski**, Ch. Schmitt, M. Ciamala et al.
Great work done by the Simulation WG!

Simulations

(O. Stezowski, Ch. Schmitt, M. Ciamala, O. Roberts, D. Lebhertz, S. Courtin,
A.K. Gourishetty, D. Chakrabarty, M. Labiche et al.)

- PARIS simulation platform: Geant4 based
 - Spherical and cubic geometry
 - Physics case generators
 - Influence of other detectors
-
- The **idea of two concentric layers seems to be rather pertinent**, as suggested by the simulations: a) the percentage of fully absorbed events in one of the 2 shells has been found rather large; b) a two-shell design is relevant provided the inner shell is not too much absorbent. In this way, the inner shell fulfils its calorimeter job, while the outer layer is devoted to the detection of high-energy photons.
 - **Detailed track reconstruction requires further work**
 - The **optimal thicknes** of the inner LaBr3 shell is **2"**, while the **diameter** of the crystals shall be around **2"** (at 15 cm distance from target).

DESIGN

POSSIBLE GEOMETRIES of PARIS

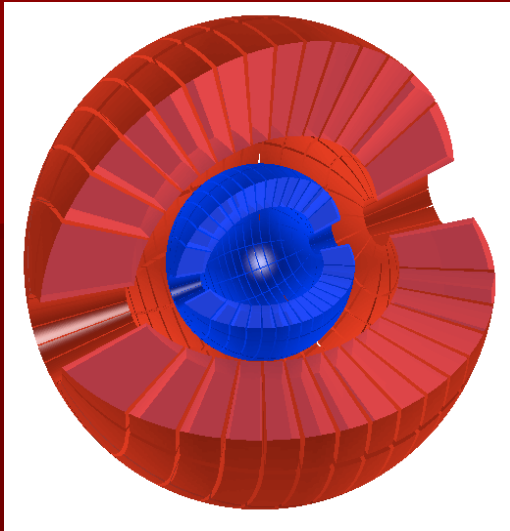

SPHERICAL (e.g. same as AGATA modules):

- + : easy reconstruction, good line shape, compability with other spherical detectors,..
- : Limited to one distance, high cost of a segment,...

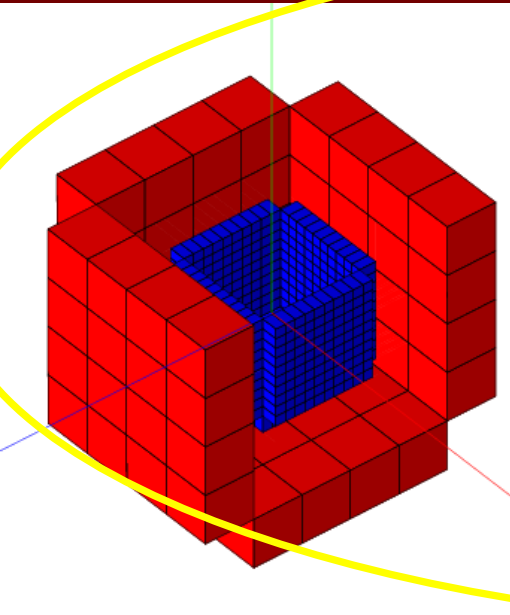

CUBIC (offering variable geometry):

- + : adjustable to different distances, compatibility with many detectors, lower cost for a segment, easier mechanical support,
- : More complicated reconstruction, worse line shape, ...

4 POSSIBILITIES FOR A „GAMMA-TELESCOPE” ELEMENT

Possibility 1.

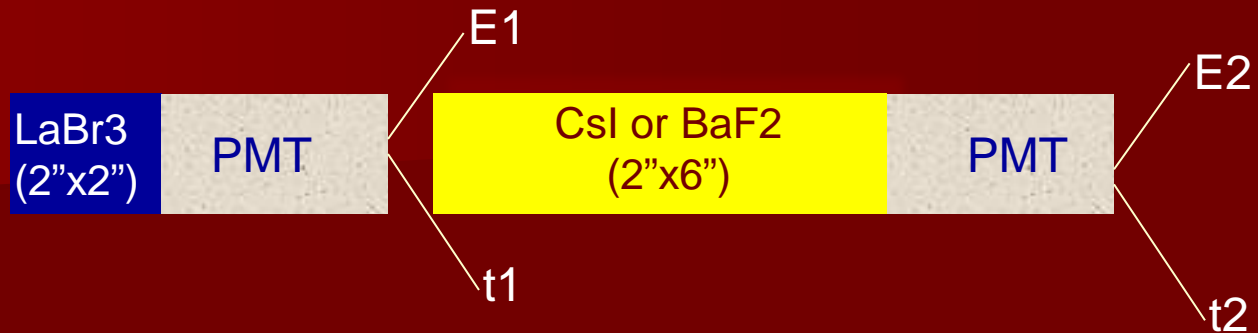

Possibility 2.

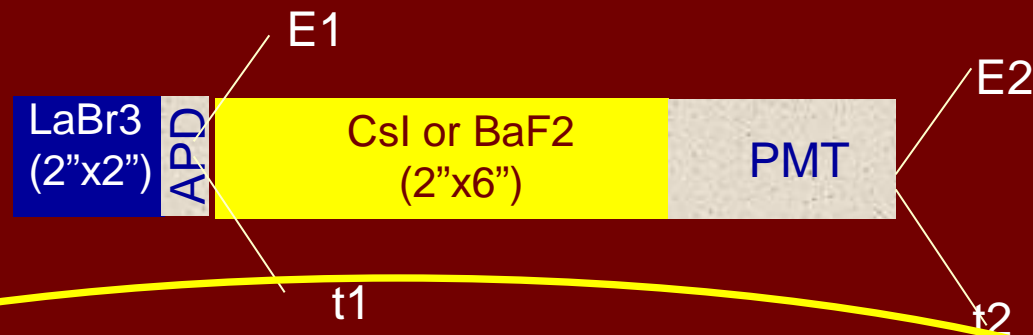

Possibility 3 – „phoswich”.

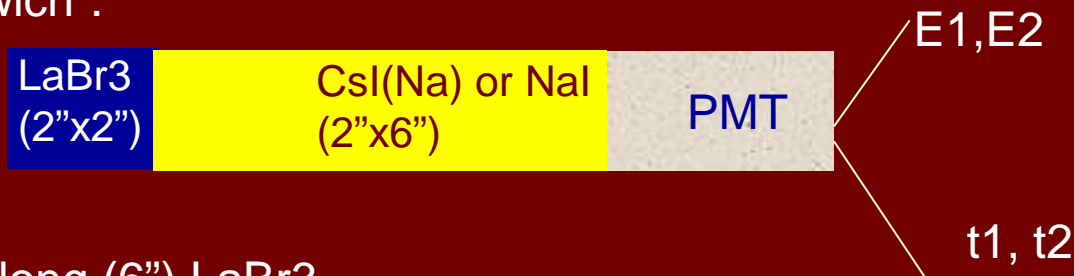

Possibility 4 – single long (6") LaBr3.

LaBr3 (2"x6")

Various cubic designs exist for different inner radii and number of detectors
(J. Strachan, A. Smith, S. Courtin, D. Jenkins et al.)

CUBIC-LIKE GEOMETRY

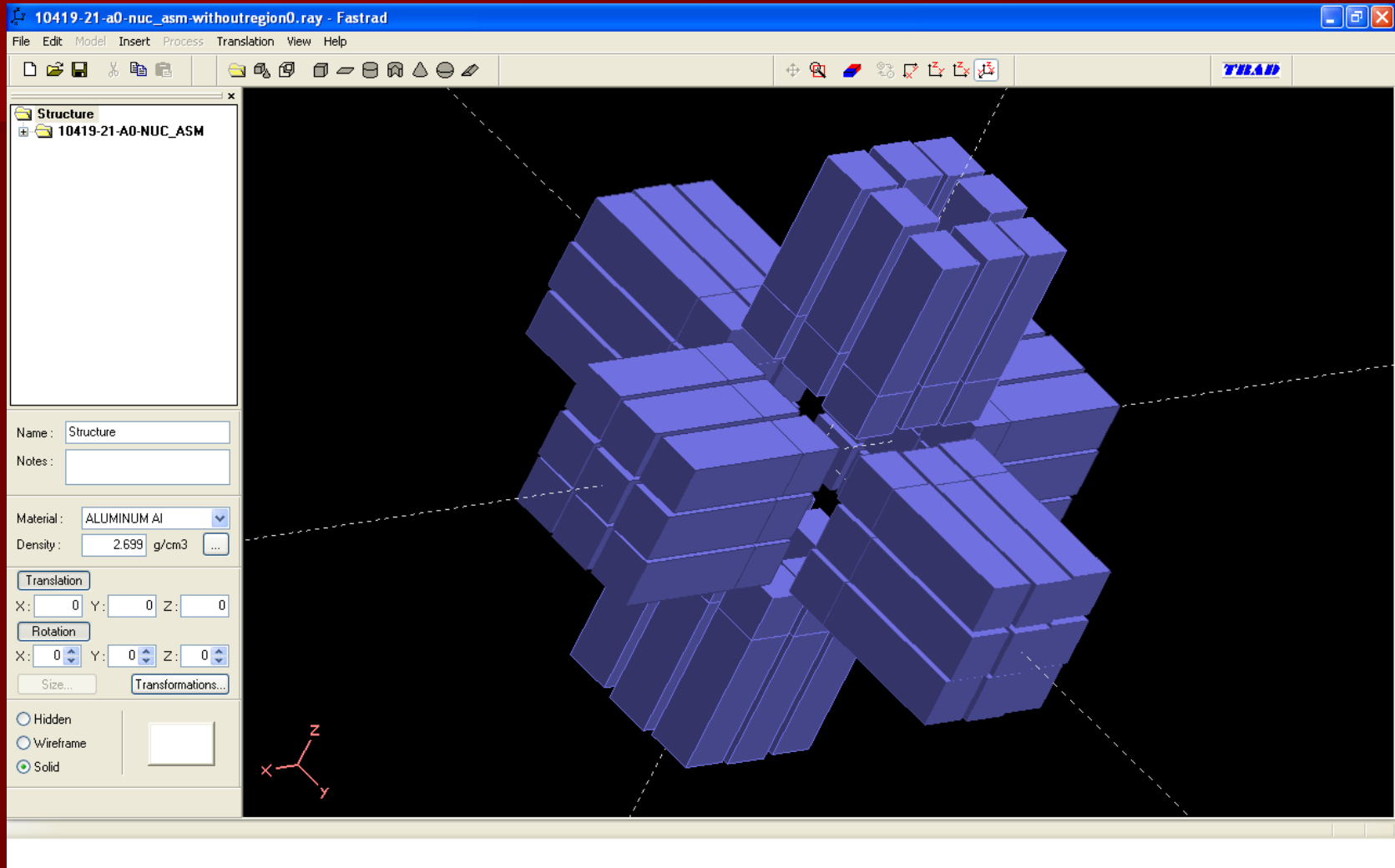

52 phoswitches - Labr3: 2"x2"x2" + Csl: 2"x2"x6" (15 cm inner radius)

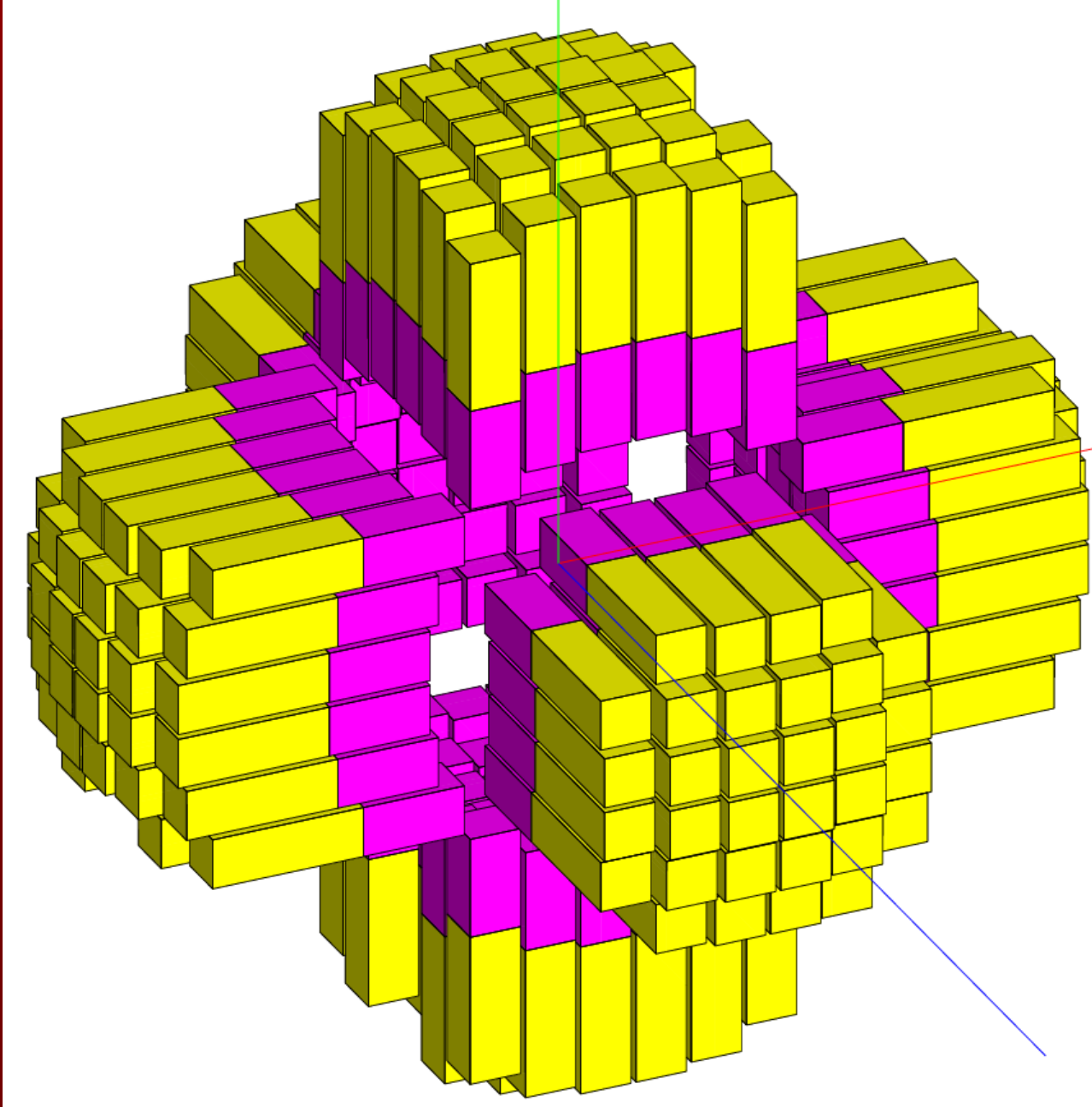

204 phoswitches - Labr3: 2"x2"x2" + Csl: 2"x2"x6" (23 cm inner radius)

ITEM	DESCRIPTION	MATERIAL	REQ'D	DRAWING NUMBER	REMARKS
1	CHAMBER R&B-225mm			10846-00-A0-NUC	
2	DETECTOR P-260MM		200	CRITICAL-COM-TRK-LABR1-001-300	

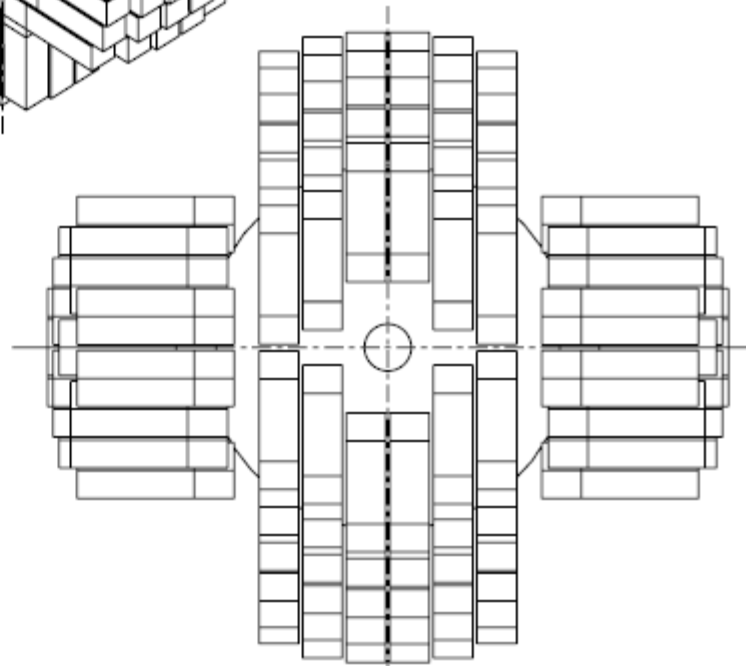
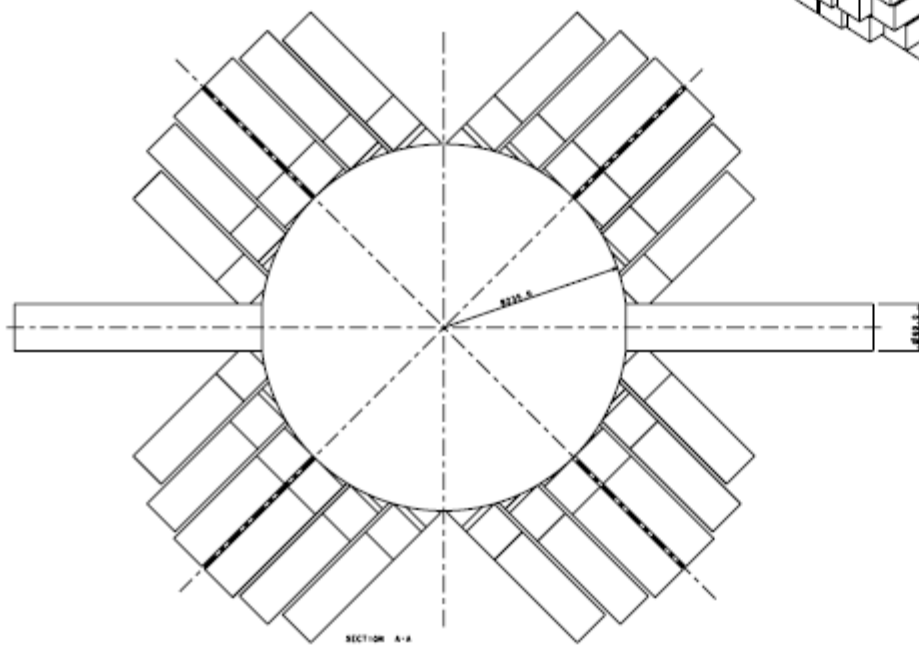
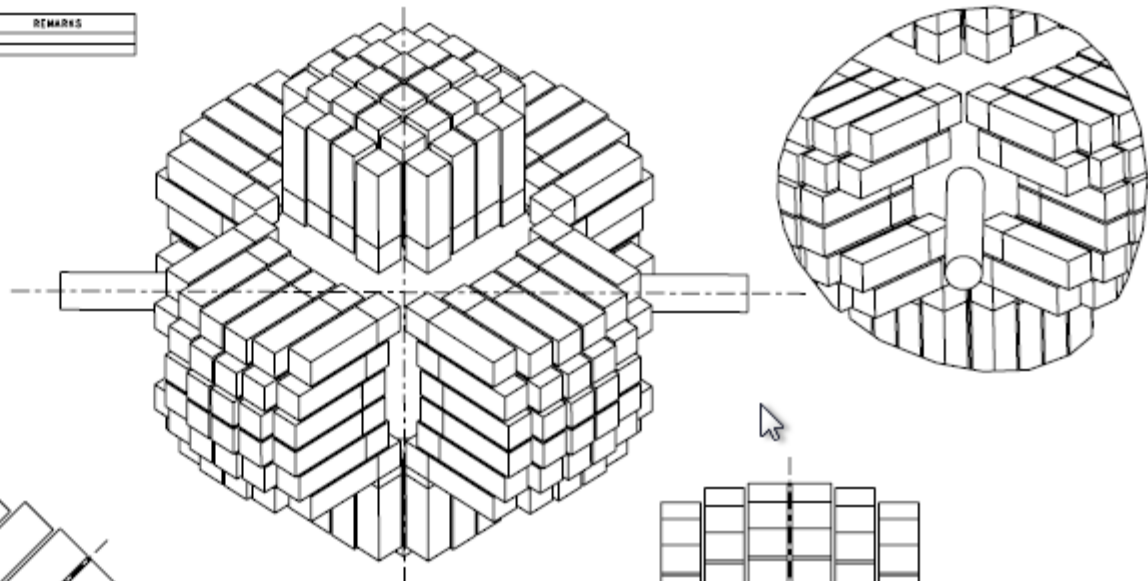

PROJECTION

DO NOT SCALE

REMOVE ALL BURRS AND SHARP EDGES

IF IN DOUBT ASK

FINISHES TO FOLLOW UNLESS OTHERWISE SPECIFIED

MATERIAL

DATE: 01/14

The University of Tennessee
School of Physics & Astronomy
Drawing Office
Drawing Practice
Mechanical 312 0A
Mechanical 312 0A
Total: 0161-210-000

27-May-16

REVISIONS (SEE DATE AND REVISION HISTORY)

LEVEL	TOLERANCES	FINISH
A	± 0.005	A
B	± 0.01	B
C	± 0.02	C
D	± 0.05	D

APPROVED BY	DATE
	1/12

DATE	BY
01/14	

TITLE
CHAMBER R&B-225mm 260 DETECTORS

10846-00-A0-NUC

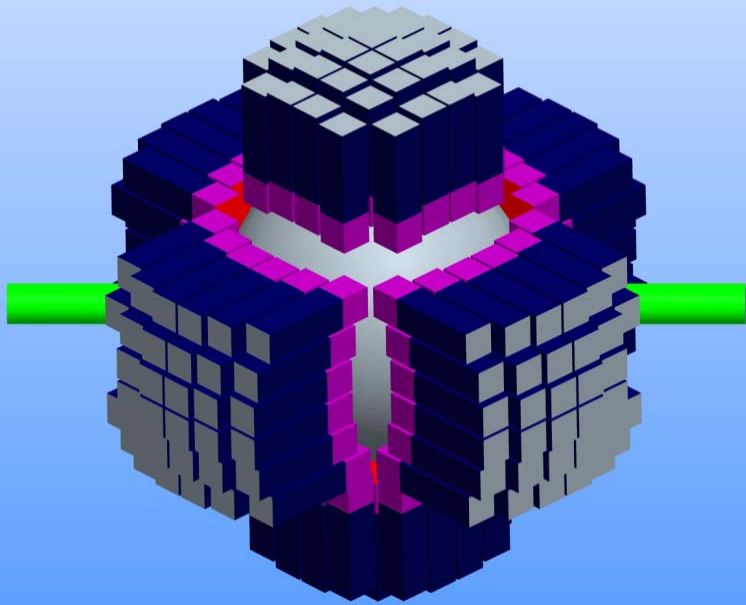

200 elements

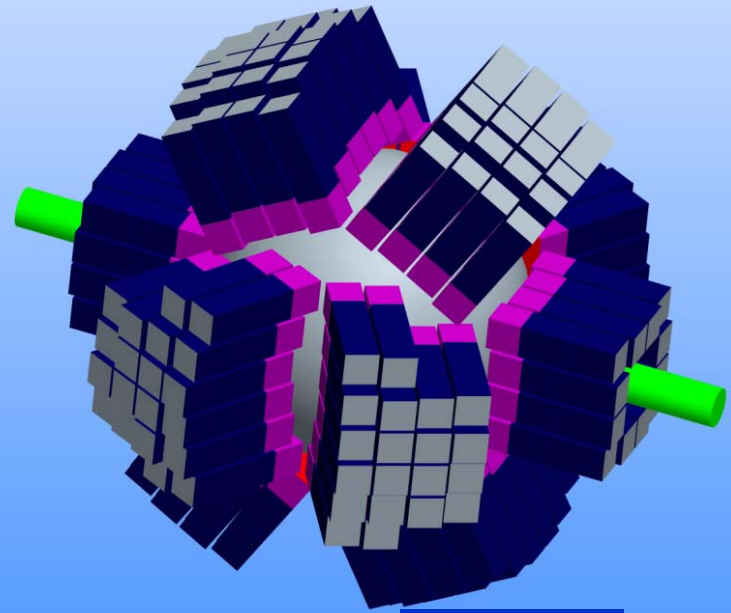

Decagon
10 faces

Cube
6 faces

Octadecagon
18 faces

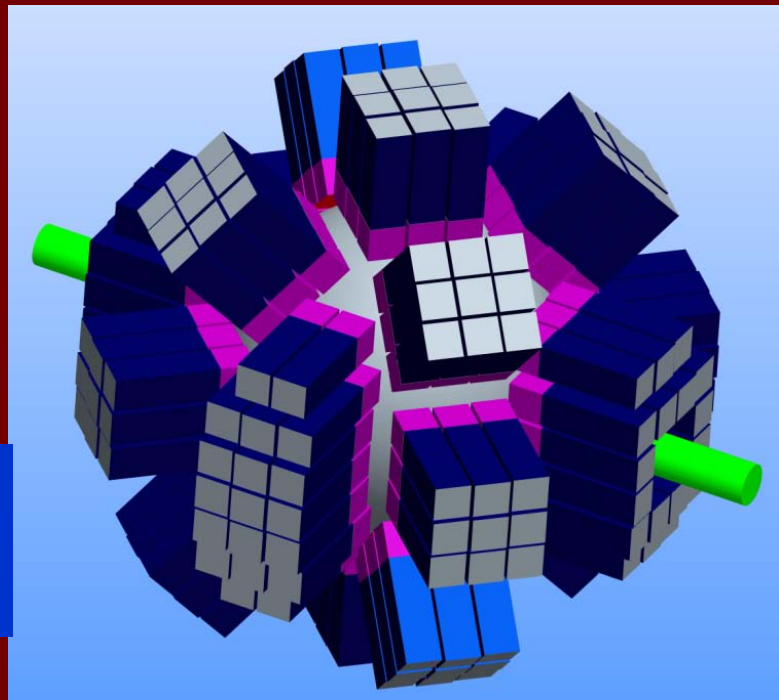

SPHERE-LIKE (RADIAL) GEOMETRY

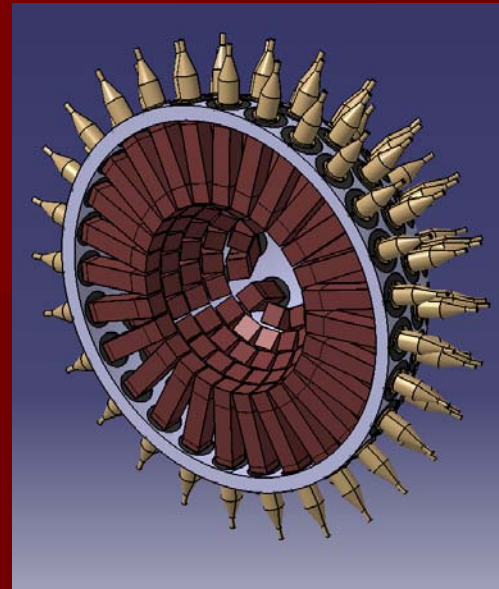
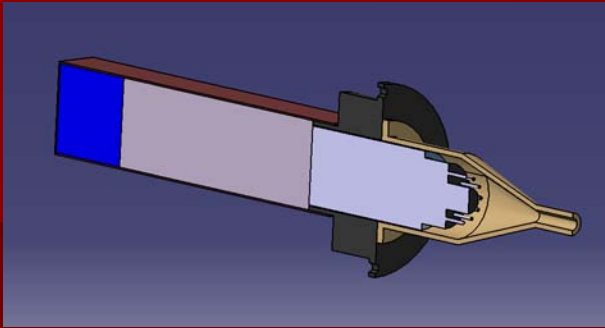

200 elements

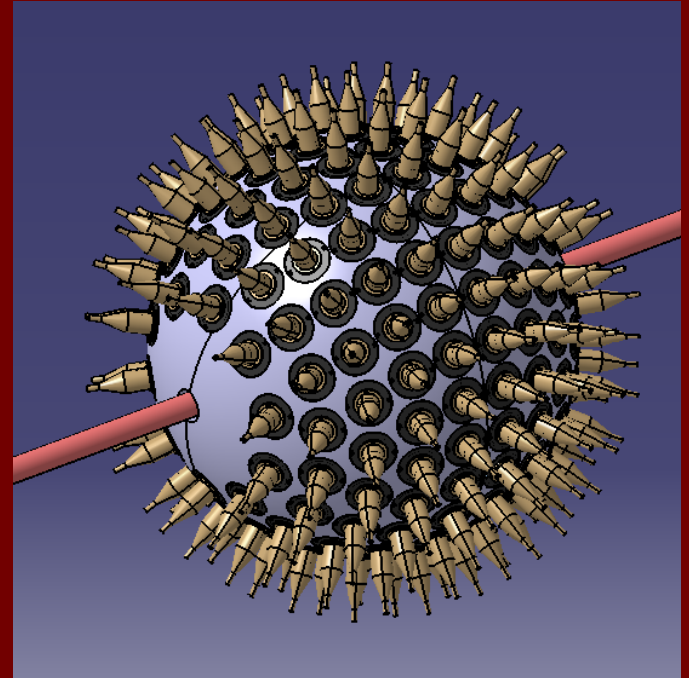
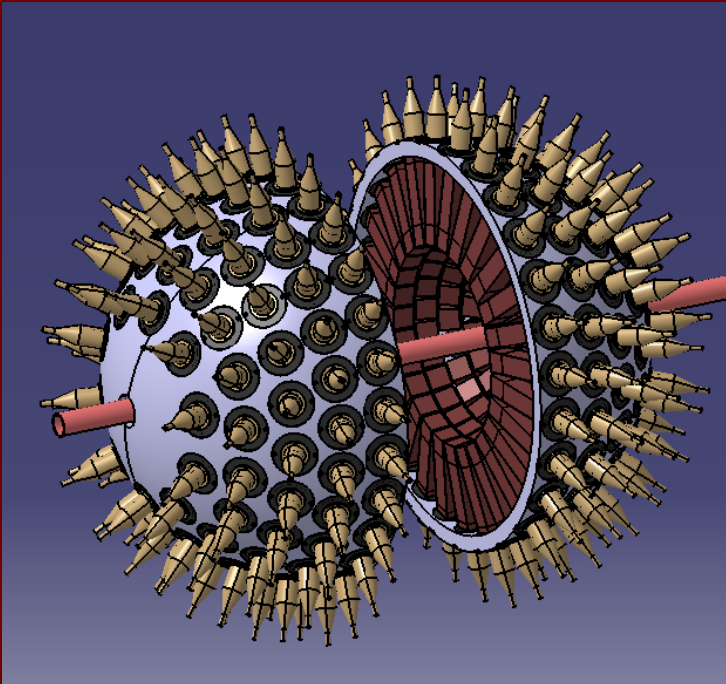

Phoswich design

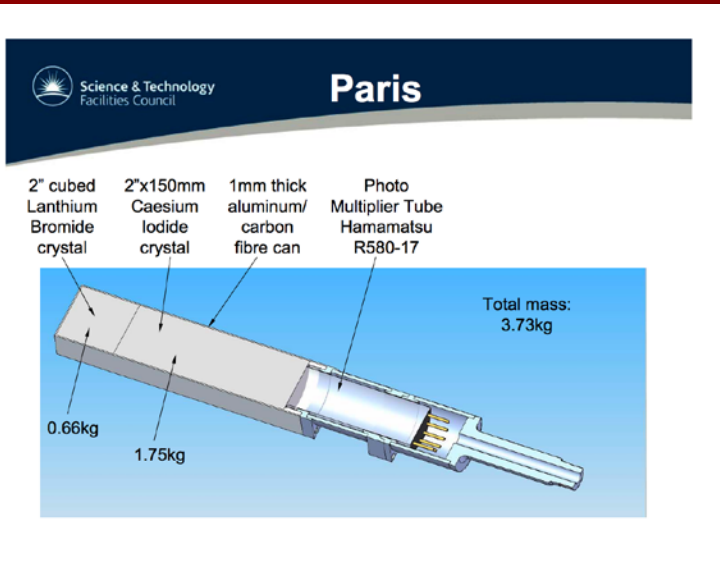

To test:

Does it work?

Is it mechanically stable?

Does it provide needed energy resolution?

How does it respond to charged particles and neutrons?

Pros:

Composite detector gives sensitivity over wider range of gamma ray energies

No space lost between crystals

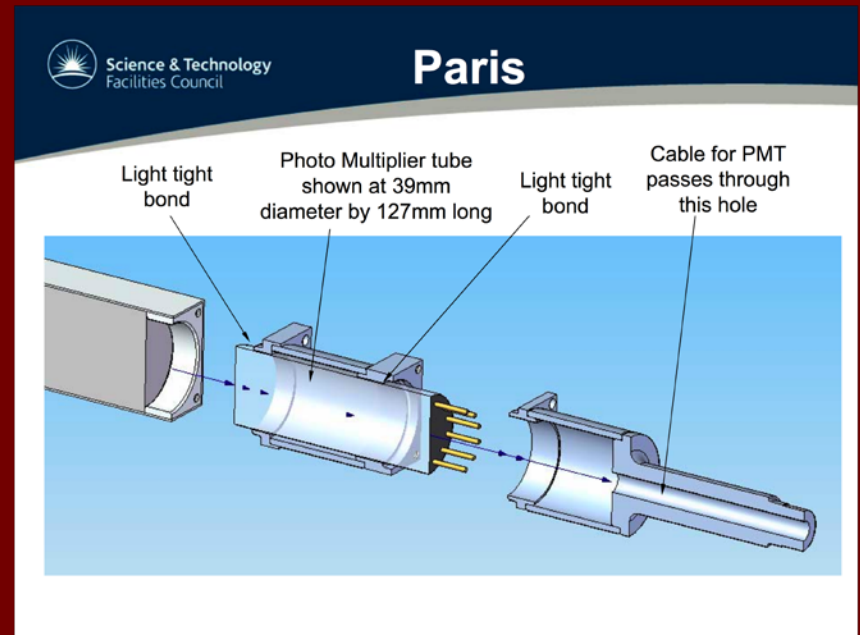

Paris

- 2" cubed Lanthium Bromide crystal
- 2"x150mm Caesium Iodide crystal
- 1mm thick aluminum/ carbon fibre can
- Photo Multiplier Tube Hamamatsu R580-17

Total mass:

0.66kg

1.75kg

Paris

Detectors can be slid forwards and backwards

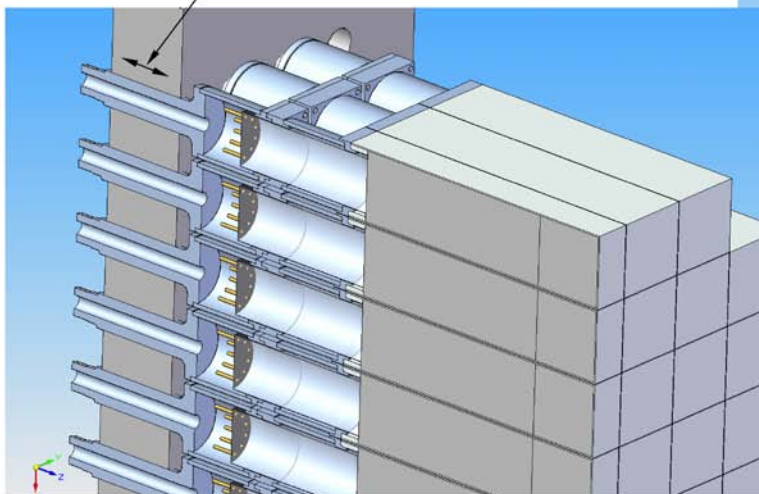

Paris

- Light tight bond
- Photo Multiplier tube shown at 39mm diameter by 127mm long
- Light tight bond
- Cable for PMT passes through this hole

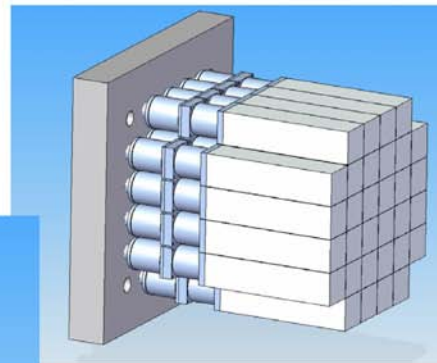

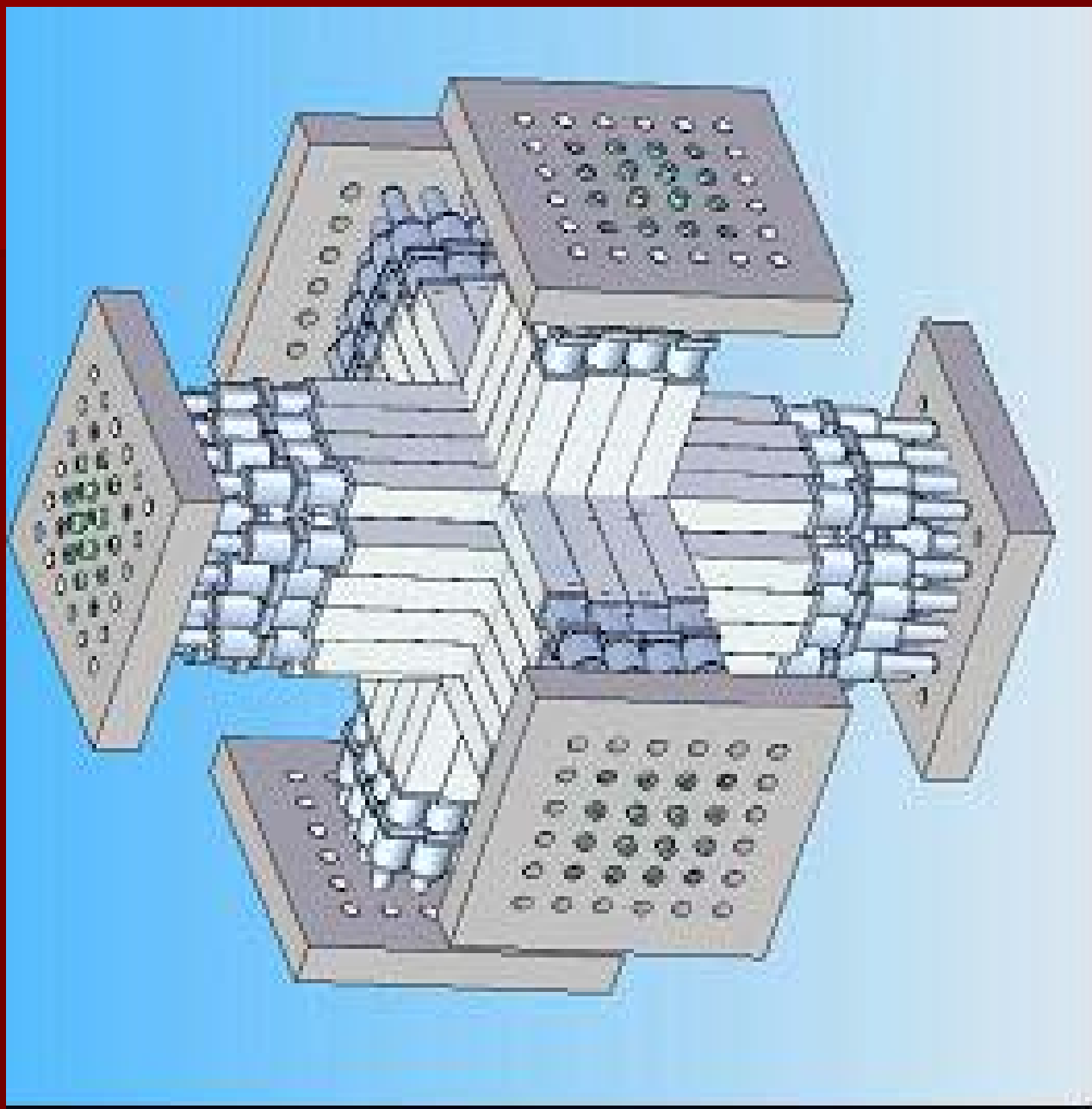

FOUNDING

PARIS in the FP7 SPIRAL2 Preparatory Phase project

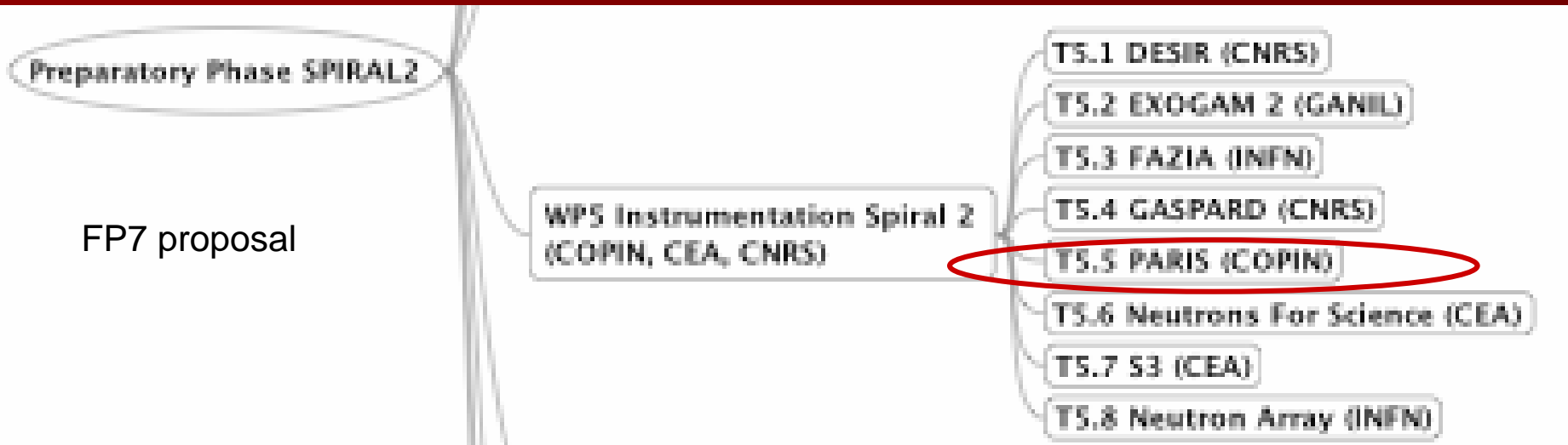

PARIS in SP2PP: Poland, France, UK, Germany, Bulgaria, Hungary

**Main goals: Design and construct PARIS prototype
Sign MoU between partners of PARIS collaboration**

~250 kEuro

Frame for common preparation with **EXOGAM2 (+Agata Demonstrator)**.
Ongoing synergy with **NEDA** and **GASPARD**
Discussion are going on with **FAZIA** and **VAMOS** groups

DETECTOR TESTING

PARIS detectors tests

Orsay, Strasbourg, York, Krakow, Warsaw

O. Dorvaux, J. Pouthas, O. Roberts, M. Ciemała, M. Ziębliński, K. Hadyńska-Klęk, I. Matea, D. Lebhertz et al.

We purchased from Saint Gobain, using SP2PP and PROVA funds, following detectors:

- Cubic 1"x1"x2" LaBr₃(Ce)
- Cubic 2"x2"x2" LaBr₃(Ce)
- Cubic 2"x2"x4" LaBr₃(Ce)



- Cylindrical phoswich 1"x2" LaBr₃(Ce)+1"x6" CsI
- Cylindrical phoswich 1"x2" LaBr₃(Ce) + 1"x6" NaI

**Energy resolution of single cubic LaBr₃
the same as cylindrical ones**

Neutron/gamma discrimination (York group)

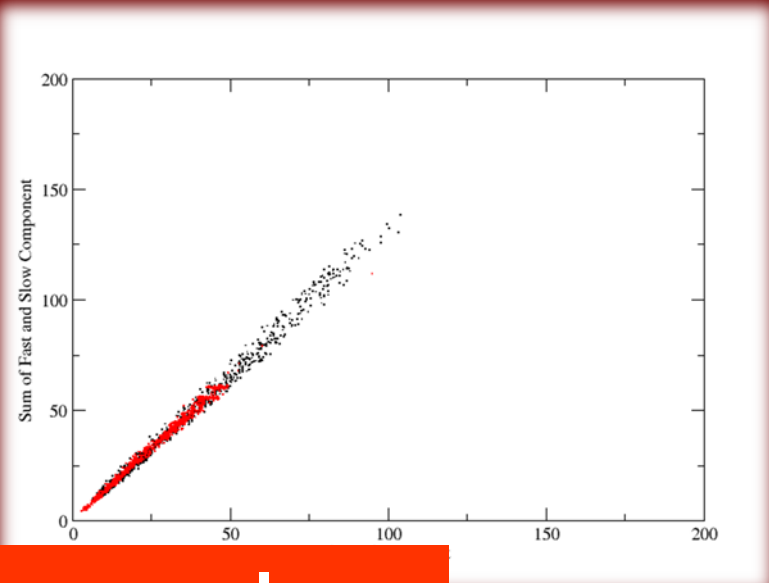
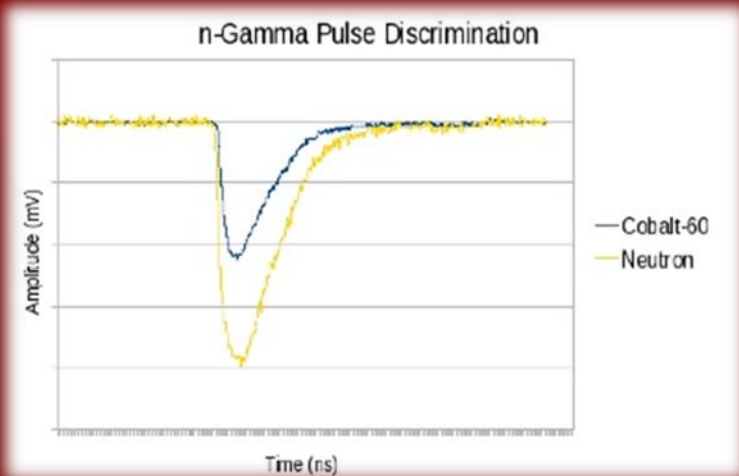

No possibility for neutron-gamma pulse discrimination – only by TOF

Test in Strasbourg, May, 2010

Goal : Looking at the resolution in the 1-12 MeV range

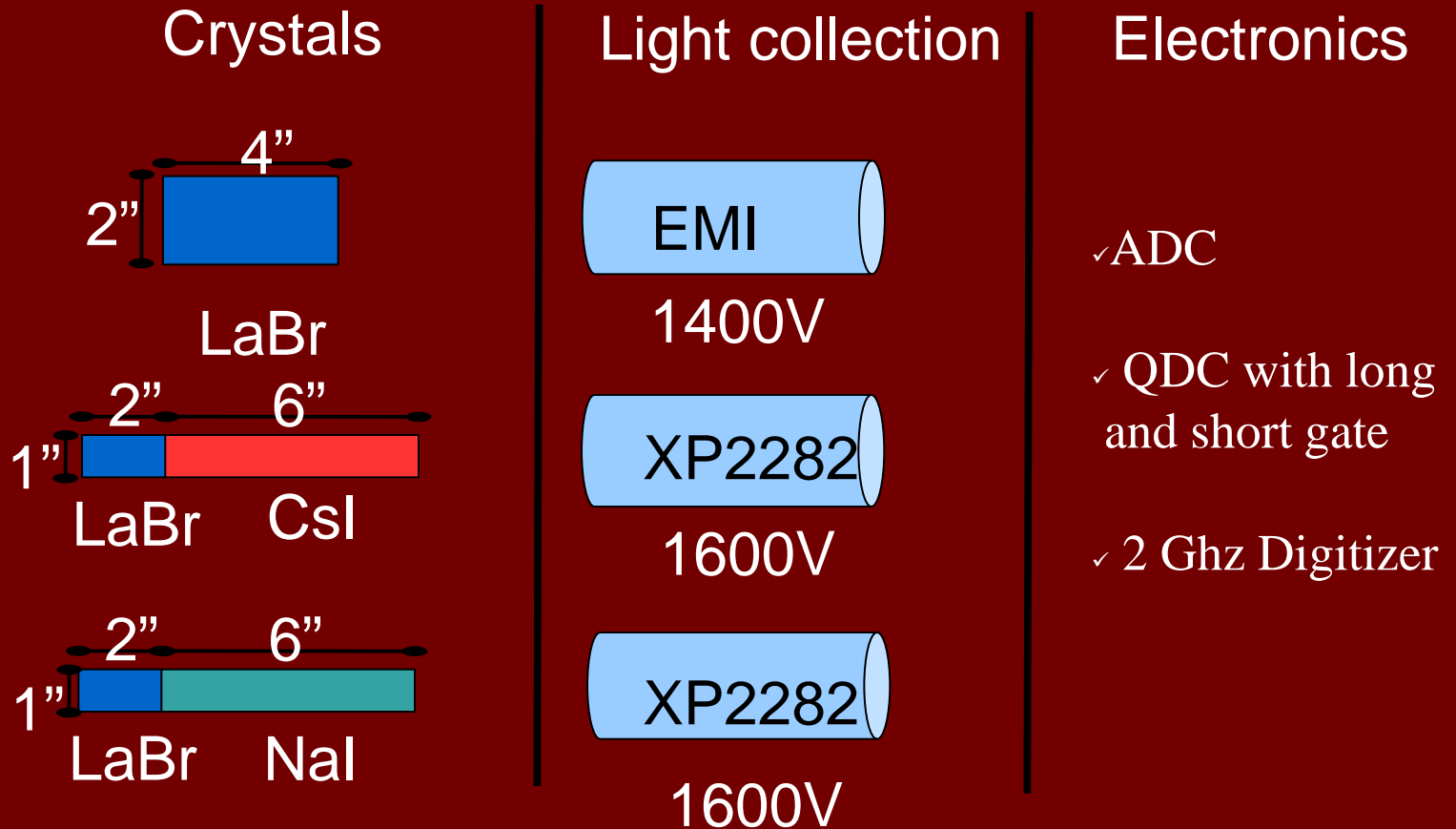

QDC spectrum: $4''\text{LaBr}$

$^{27}\text{Al}(p, \alpha)^{28}\text{Si}$ @ $E_L = 767 \text{ keV}$ ($^{28}\text{Si} E^* = 12.32 \text{ MeV}$)

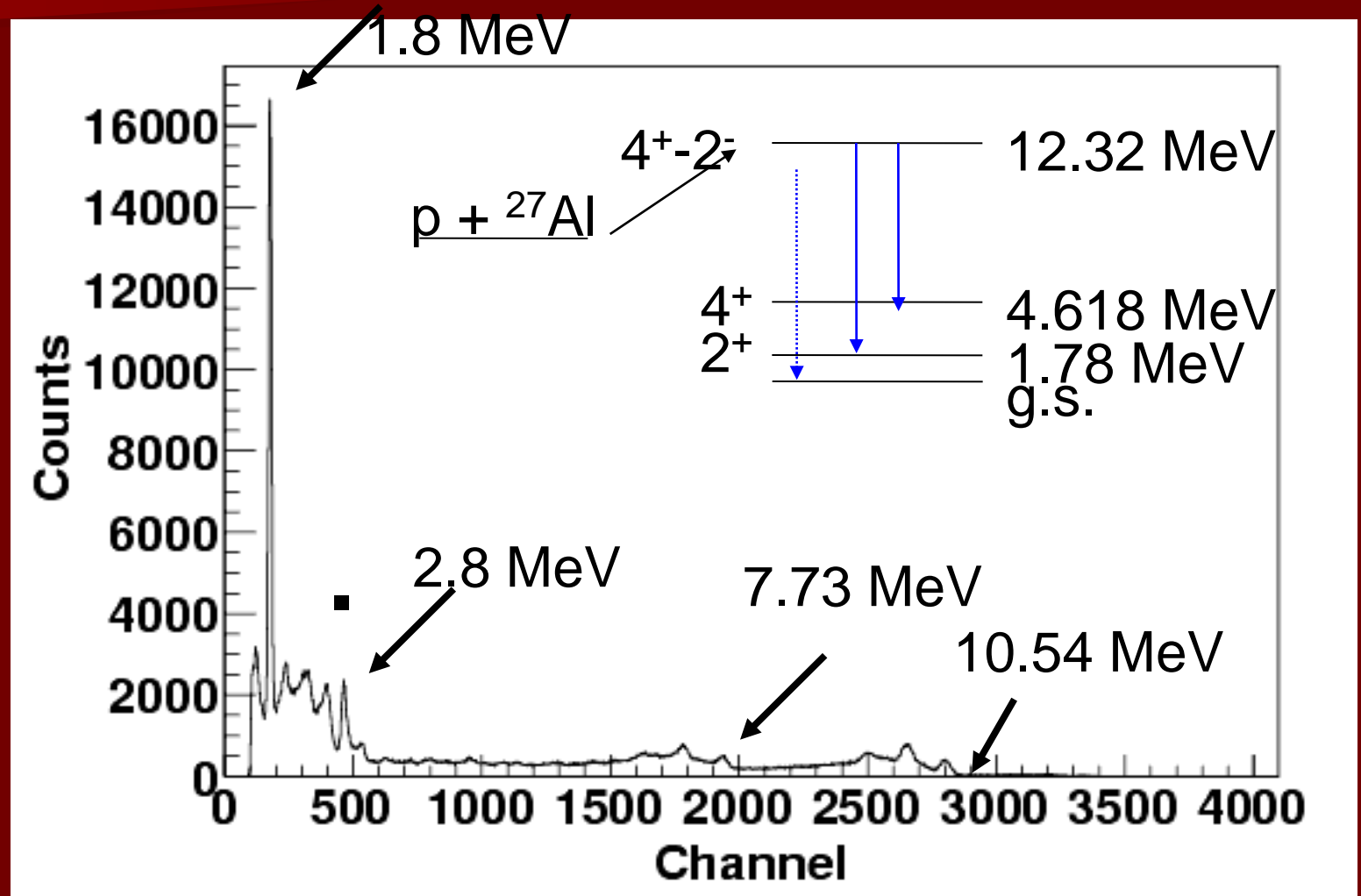

QDC spectrum: $4''\text{LaBr}$

$^{27}\text{Al}(p, \alpha)^{28}\text{Si}$ @ $E_L = 767 \text{ keV}$ ($^{28}\text{Si} E^* = 12.32 \text{ MeV}$)

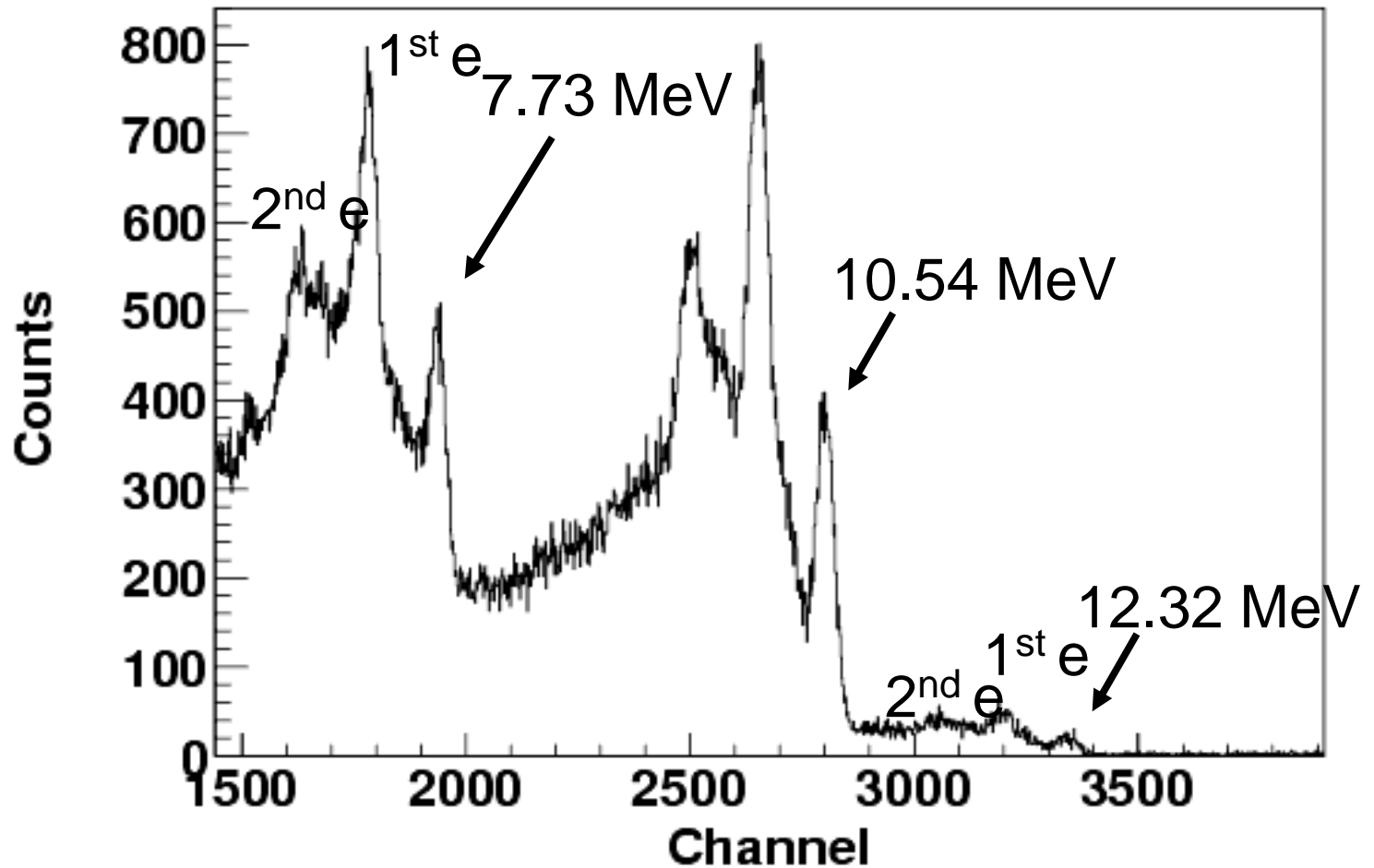

Preliminary phoswich test results

- Cubic Phoswich: 1"x1"x2" LaBr3 + 1"x1"x6" CsI(Na)

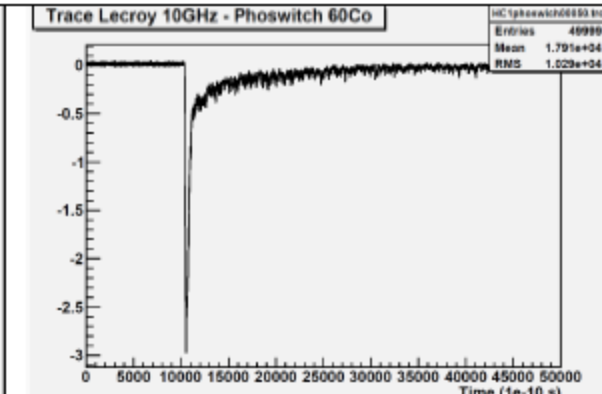
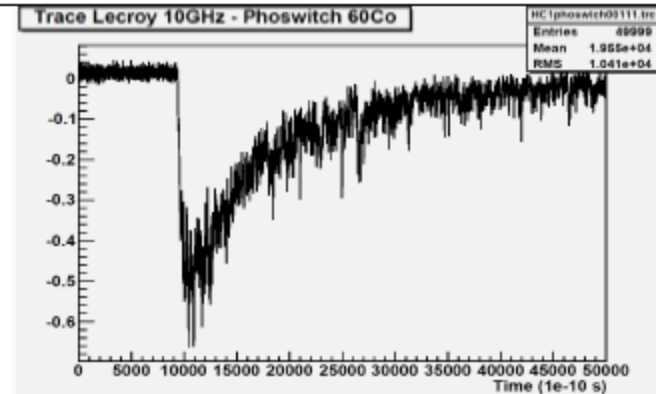
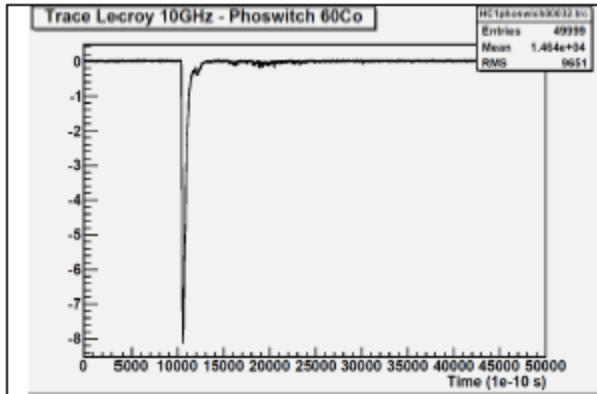

Fig. 4a: Signal corresponding to the event which deposited energy only in LaBr3

Fig. 4b: Signal corresponding to the event which deposited energy only in CsI(Na)

Fig. 4c: Signal corresponding to the event which deposited energy in both crystals

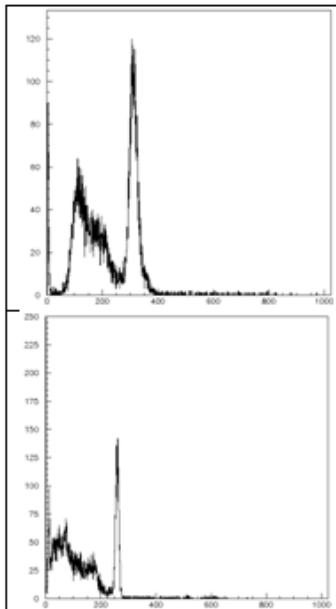

Fig. 5a: Spectra for ^{137}Cs for the events, when the whole energy is deposited in LaBr3 (bottom) and

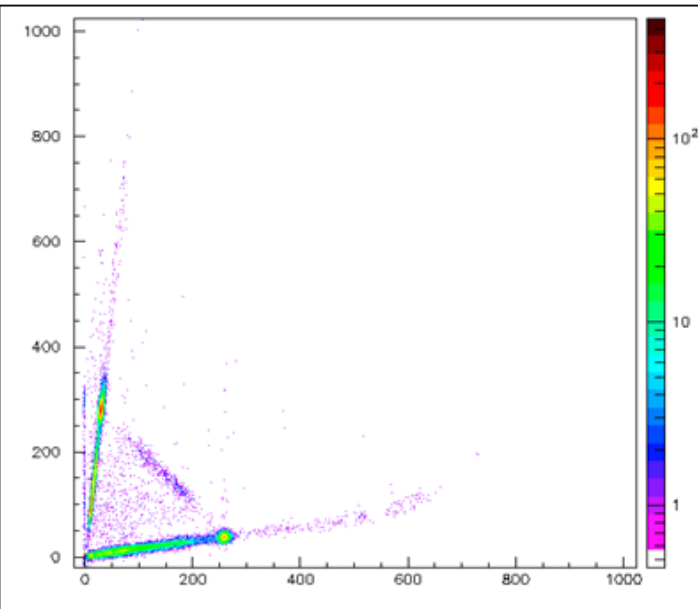
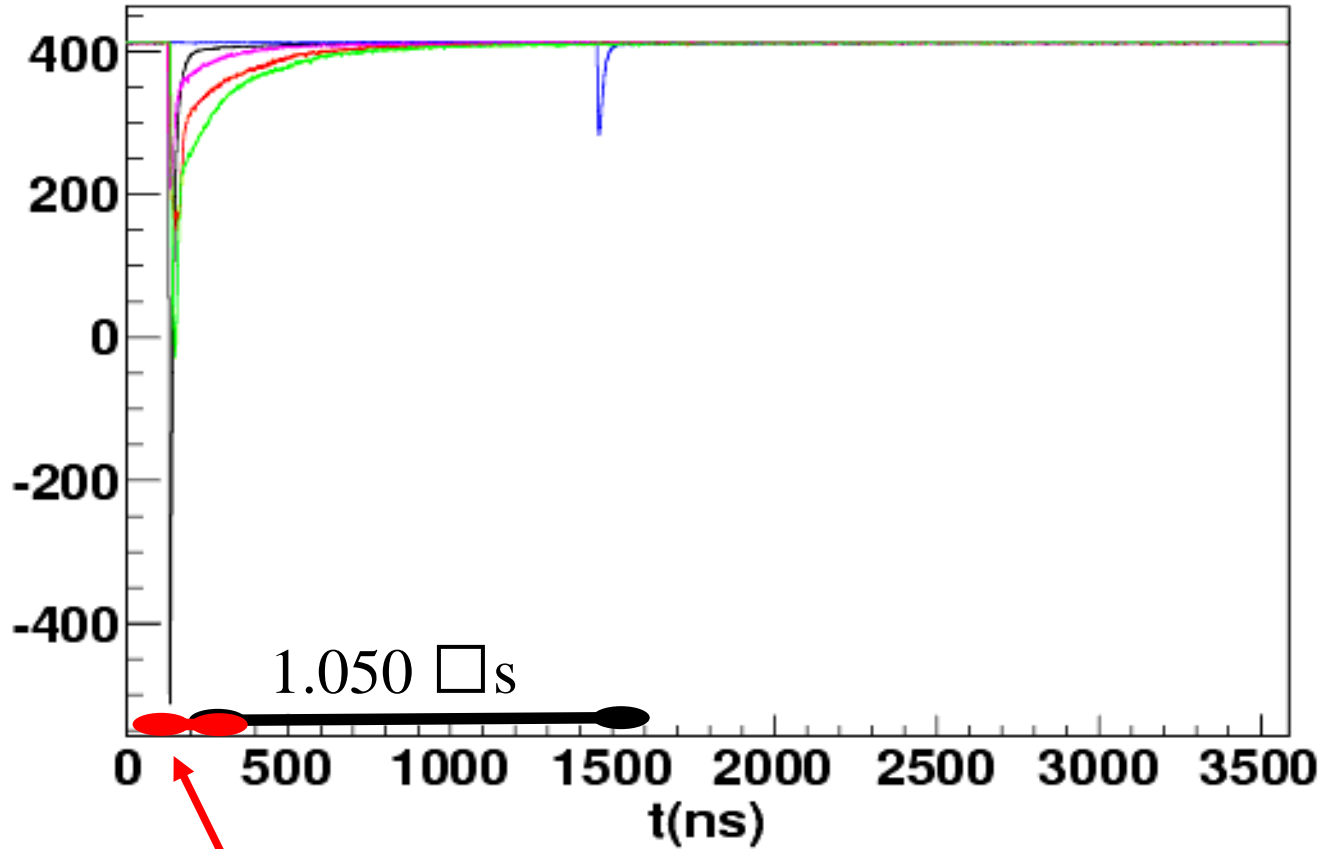

Fig.5b: Correlation plot between events deposited in LaBr3 (x-axis) and CsI (y-axis), when the detector was exposed to 661 keV gamma radiation from ^{137}Cs source

LaBr3+CsI Phoswich oncept seem to work, but poor performtance

Signal from LaBr3-NaI phoswich



150 ns

Qslow/ Qfast PWNaI: sources

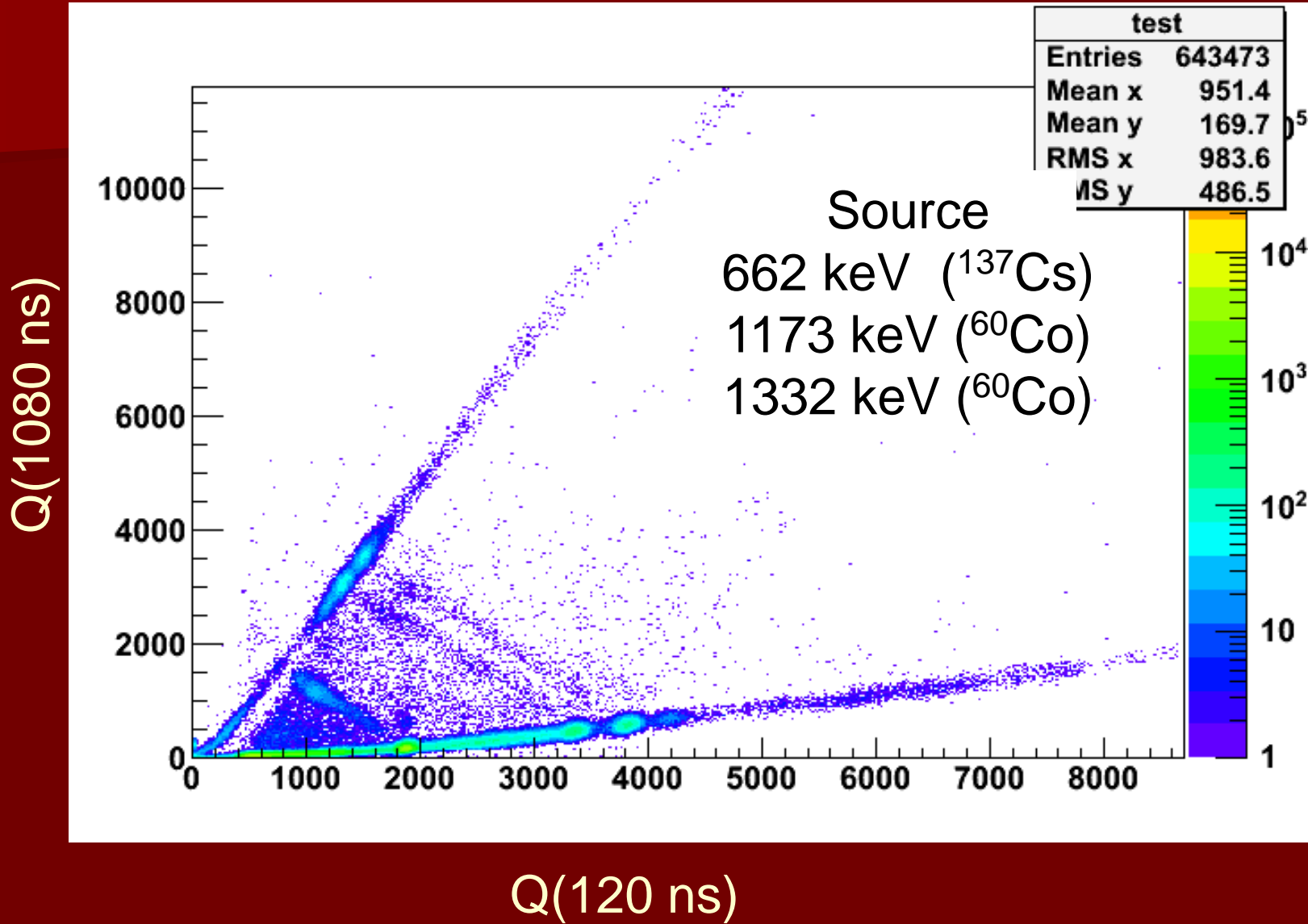

PWNaI in beam

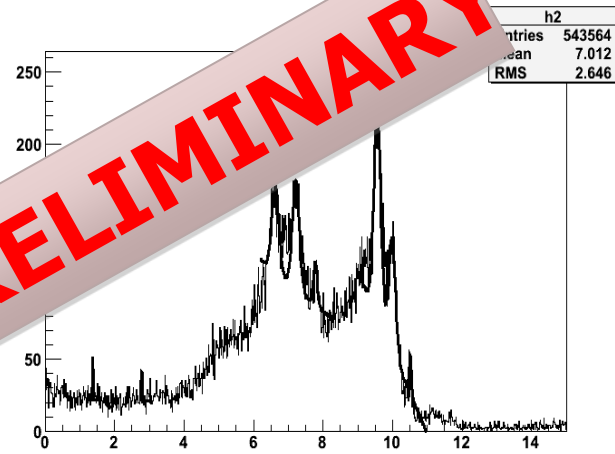
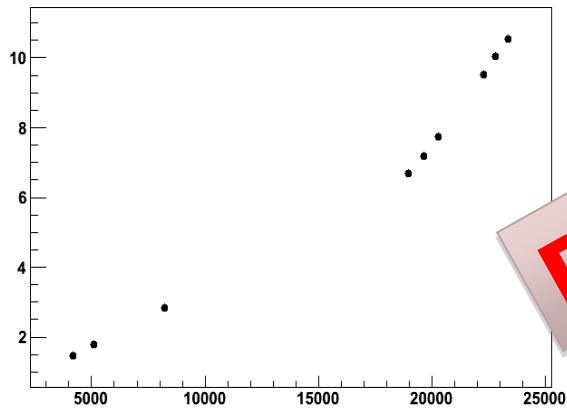
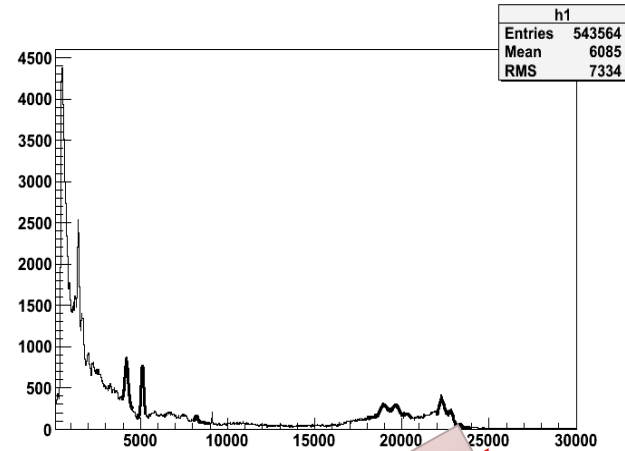
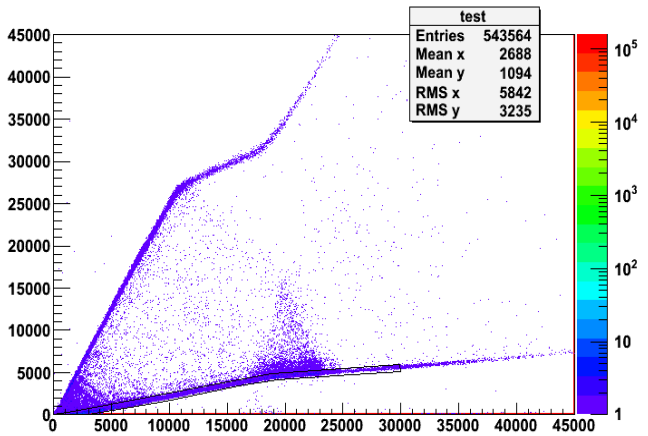

PRELIMINARY

Pwoswich tests performed at Orsay

Energy Resolutions (FWHM) LaBr₃(Ce)+PMT+ADC+¹³⁷Cs

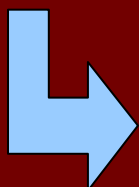
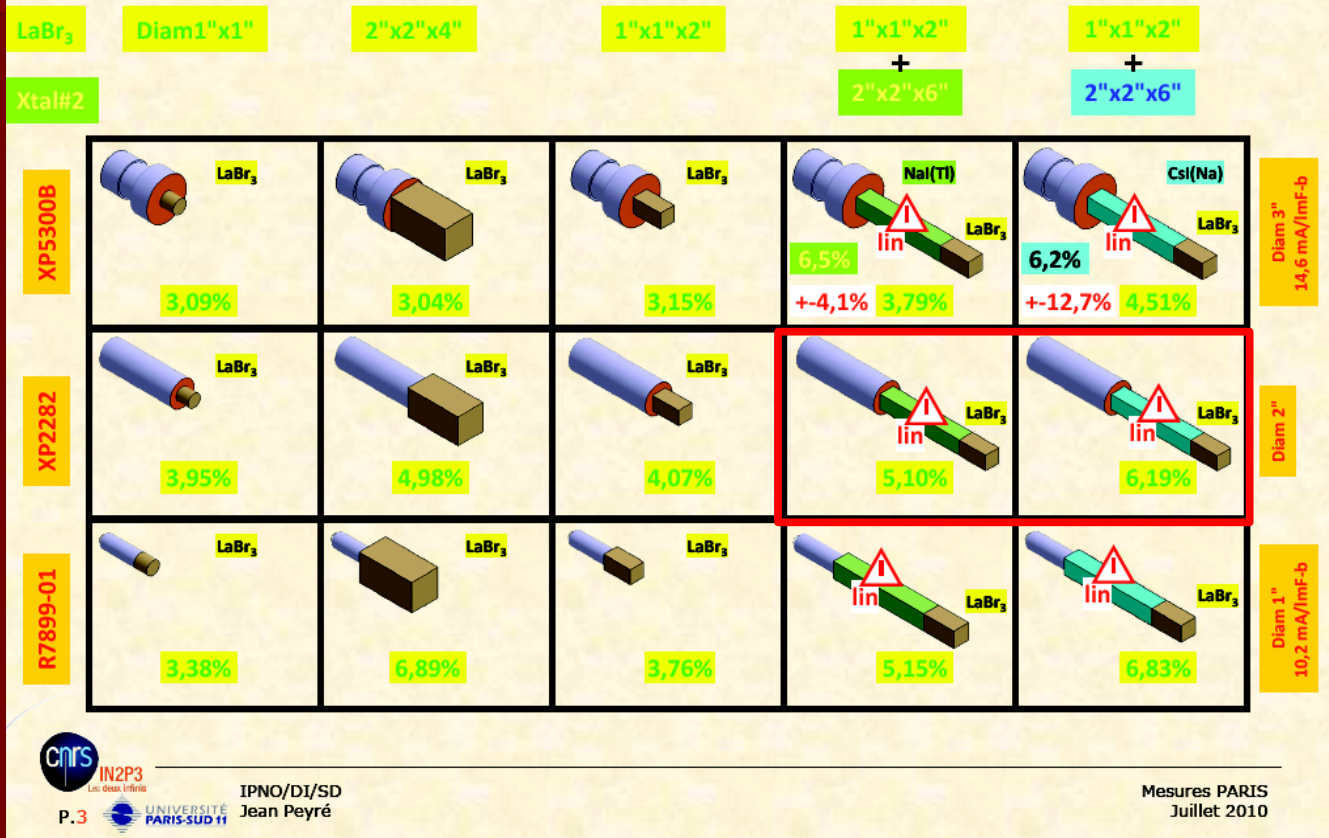

Resolution is very dependant on the size and type of PM
-> In beam test has to be repeat with new PM.

Conclusion on the performance:

- Long pure LaBr₃ gives very good resolution and reasonable linearity
- LaBr₃+CsI do not perform satisfactory
- Phoswich concept in case of LaBr₃+NaI seems to work
- Further test on resolution and linearity needed

Electronics

- **Designing the HV supply – Sofia**
- **Digital Electronics – GANIL, Strasbourg, Krakow, Orsay**
- **DAQ – GANIL, Orsay, Krakow**

A.Czermak (Krakow) represents PARIS in the ICC *SPIRAL2 ELECTRONICS WG*
X.Grave (Orsay) represents PARIS in the ICC *SPIRAL2 DAQ WG*

- **Clock distribution, time stamping and trigger system:**
- **Two systems are emerging: GTS and MUTANT**
- **EXO GAM2, PARIS, NEDA will implement the GTS.**

WHAT NEXT?

Cubic vs. Radial geometry

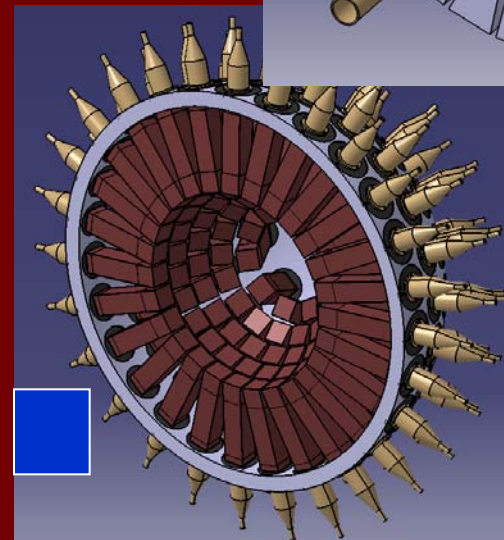
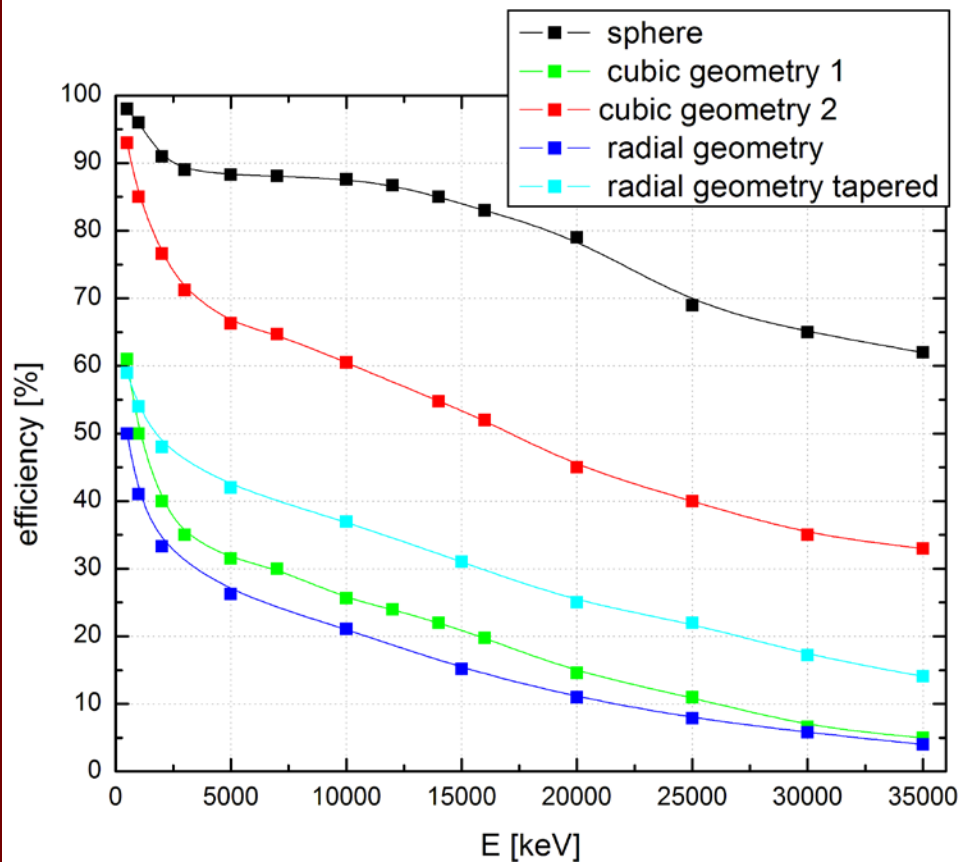
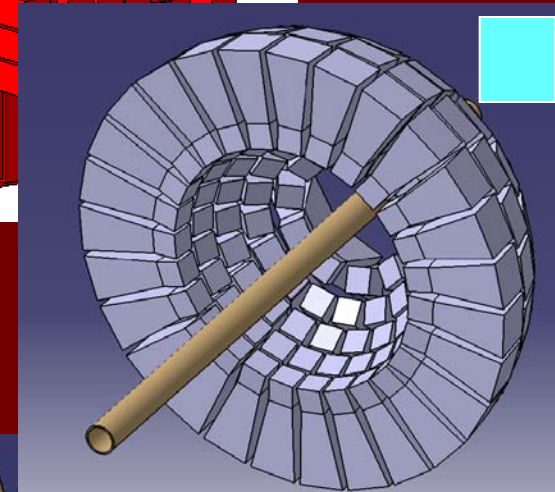
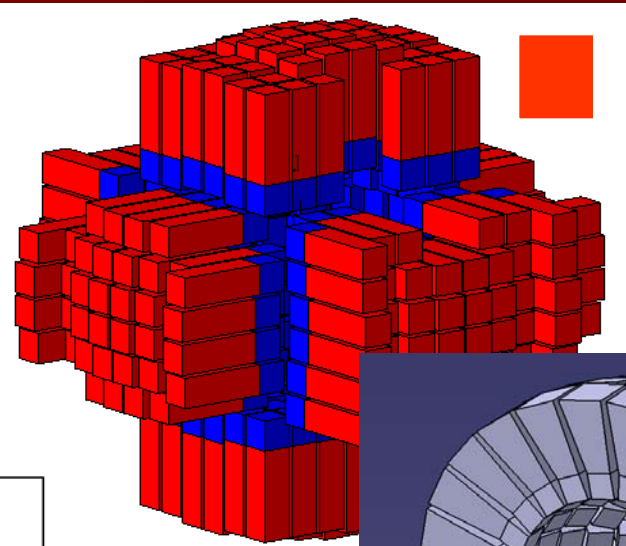
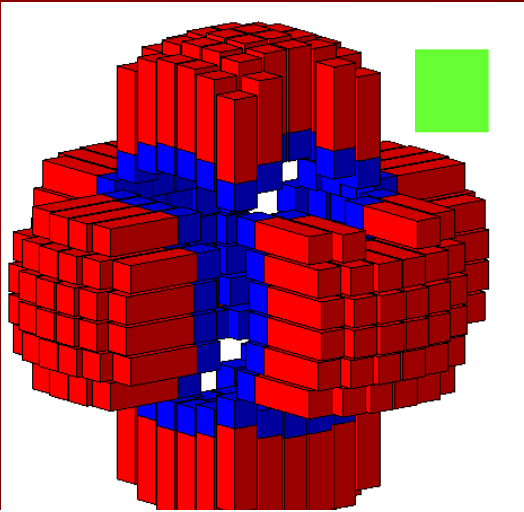
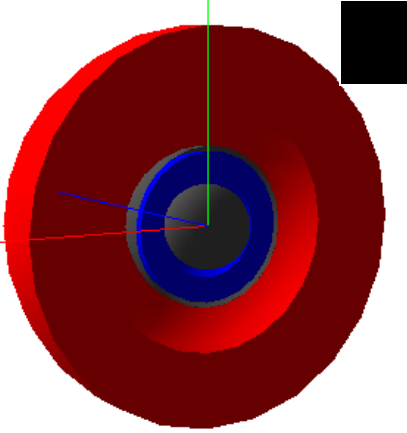

Proposed next steps

1. Detailed tests of phoswich

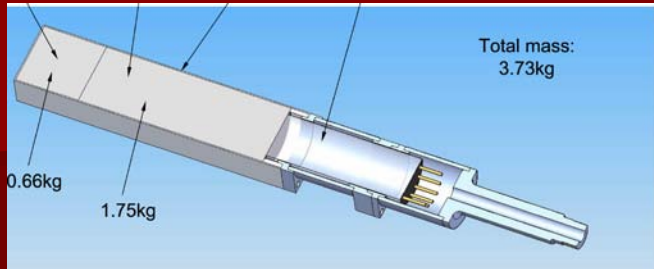

2. Purchasing – Testing *PARIS PROTOTYPE* made of 2 CLUSTERS:

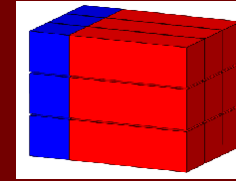

a) of 9 LaBr+NaI phoswiches;
(about to be ordered)

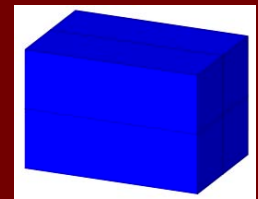

b) of 9 single LaBr₃ crystals 6" long

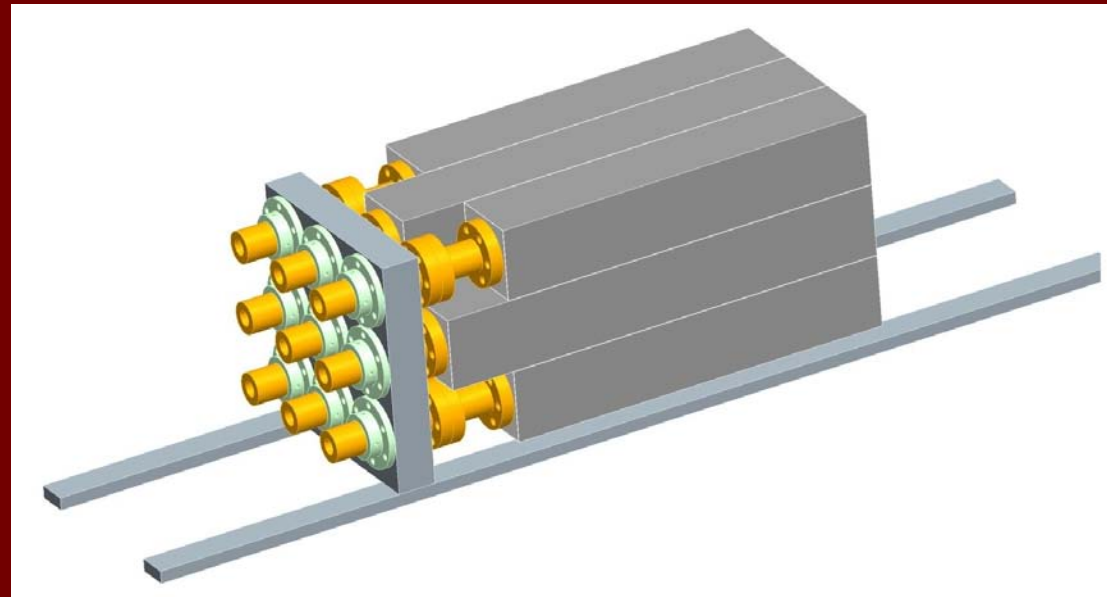
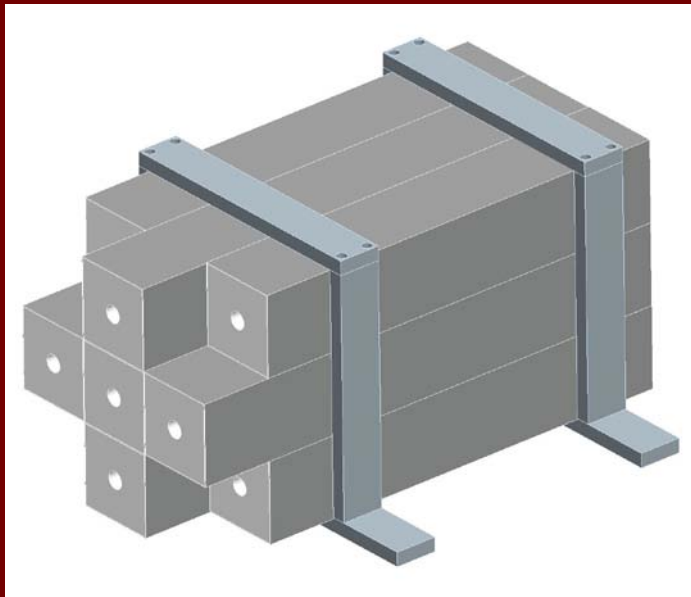

3. After testing prototype decide if:
phoswich or pure LaBr₃ or hybride of both types

4. Sign **MoU** between partners and purchase/assembly clusters into
a) *PARIS DEMONSTRATOR* (1π);
b) full 4π *PARIS array*.

It can be arranged either in **cubic** or **radial geometry**.

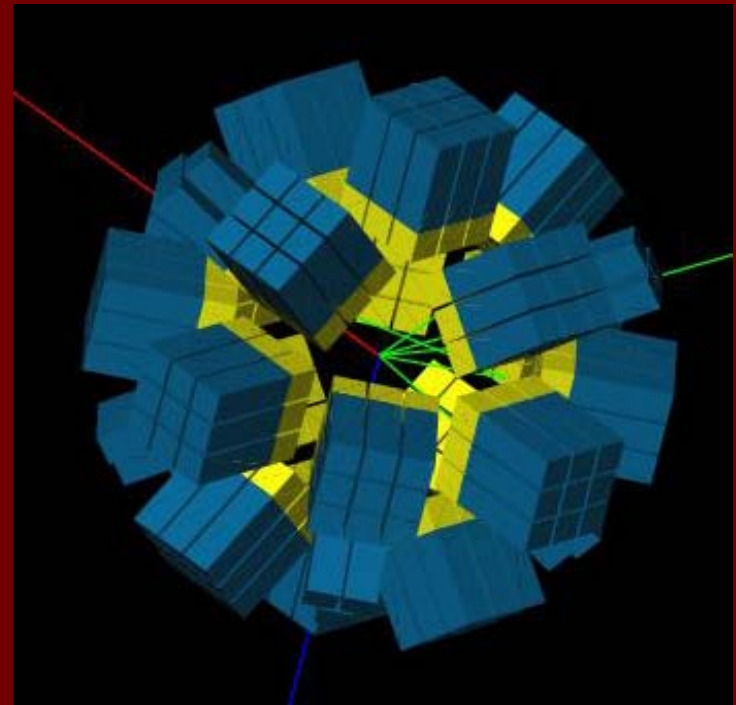
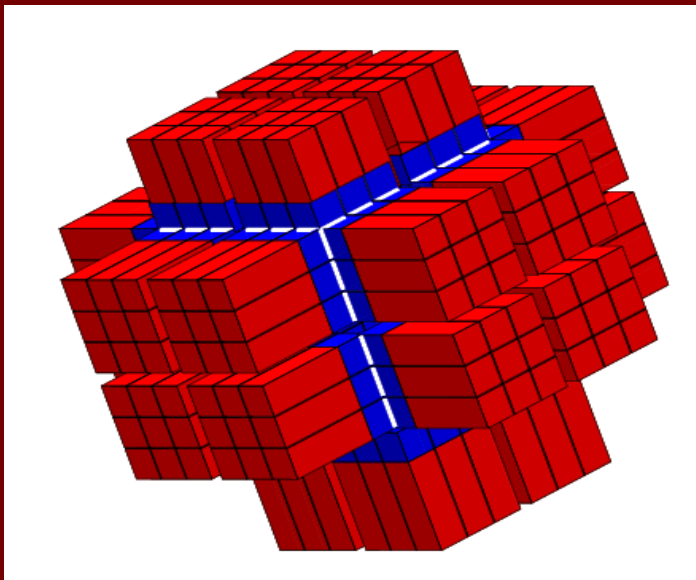

Such arrangement will be compatible with other detectors,
e.g. AGATA, GASPARD, NEDA, FAZIA,...

Preliminary TIME SCHEDULE

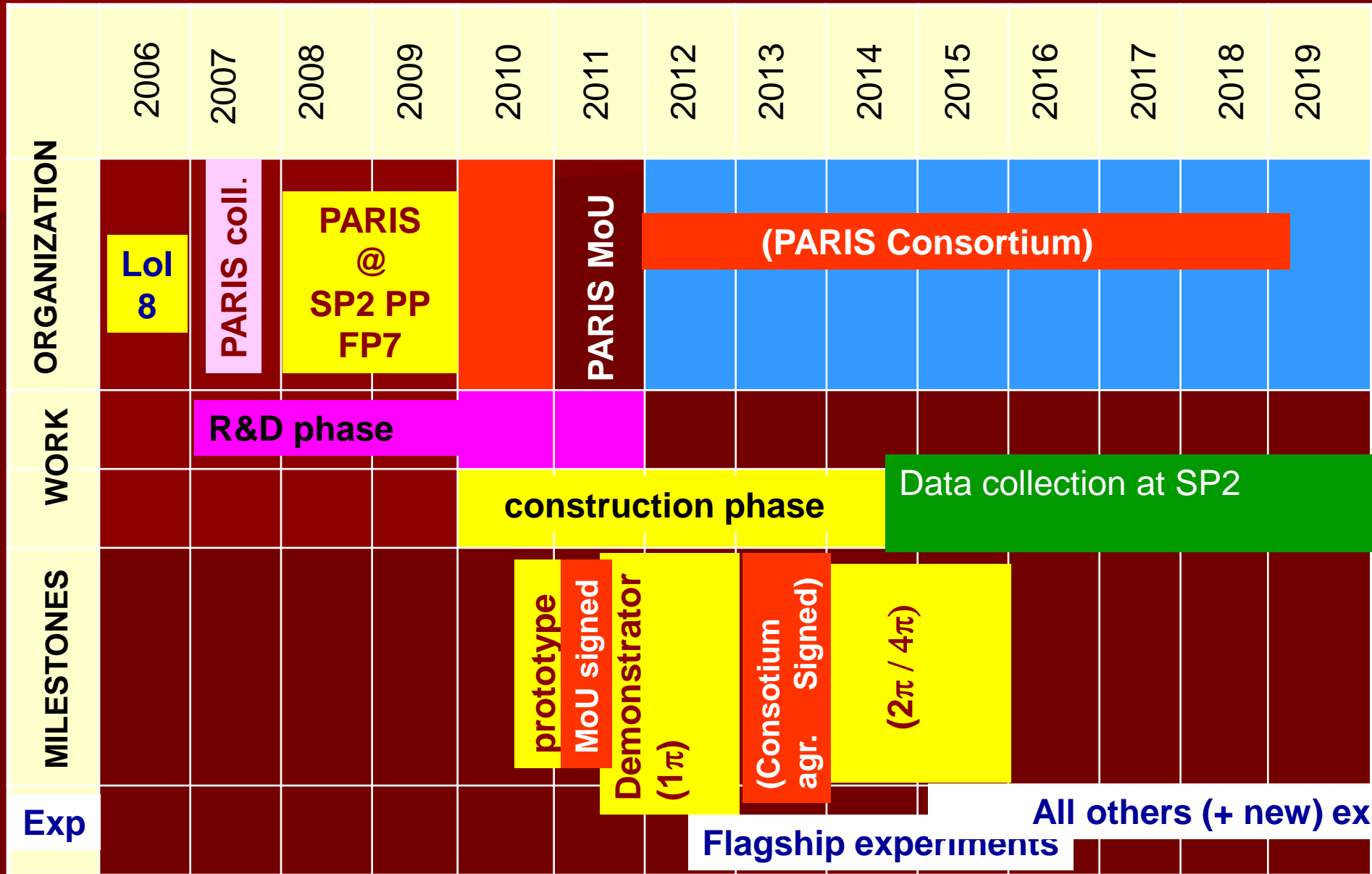

Cost estimate for some possible scenarios of PARIS

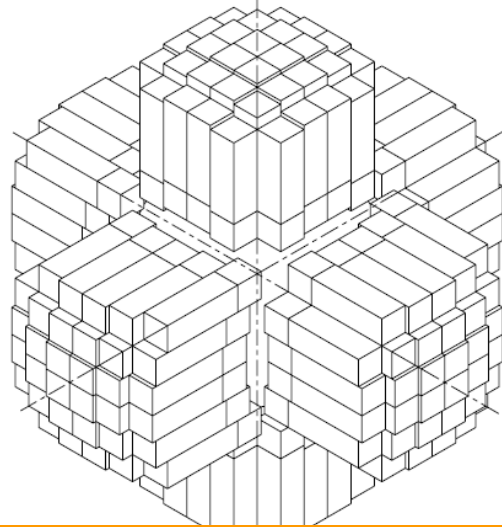
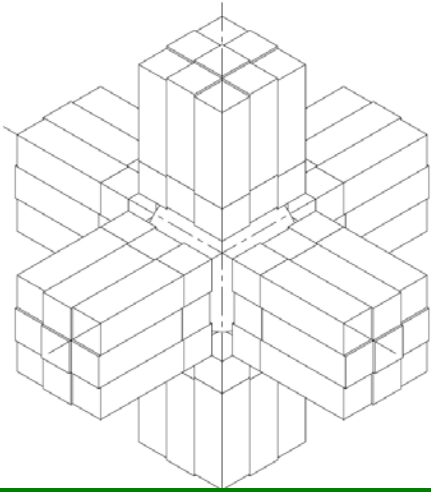

a) *Low granularity*
(Demonstrator?):

54 phoswiches

LaBr₃: 2"x2"x2"

Nal: 2"x2"x6"

(15 cm from target)

54*17 k€ = **0.92 M€**

+ cost of 216 channel
electronic

b) *Medium granularity:*

200 phoswiches

LaBr₃: 2"x2"x2"

Nal: 2"x2"x6"

(20 cm from target)

200*17 k€ = **3.4 M€**

+ cost of 800 channel
electronic

c) *High granularity:*

800 phoswiches

LaBr₃: 1"x1"x2"

Nal: 1"x12"x6"

(20 cm from target)

800*8 k€ = **6.4 M€**

+ cost of 3200 channel
electronic

For 6" long LaBr₃:

54*32k€ = **1.7 M€**

200*32k€ = **6.4 M€**

≈12 M€

Thanks to:

M. Kmiecik, M. Ciemała, P. Bednarczyk, B. Fornal, K. Mazurek - *Kraków*,
F. Azaiez, J. Pouthas, A. Scarpaci, I. Matea, D. Beaumel – *Orsay*
J.P. Wieleczo, Ch. Schmitt, D. Lebhertz - *GANIL*,
D. Jenkins, O. Roberts – *York*,
O. Stezowski– *Lyon*,
S. Courtin, O. Dorvaux, M. Rousseau, Ch. Finck J. Dudek – *Strasbourg*,
M. Csatlos, Z. Dombradi – *Debrecen*,
I.Mazumdar, D.R. Chakrabarty, V. Nanal, A.K. Gourishetty – *BARC&TIFR Mumbai*,
J. Strachan– *Daresbury*
A.Smith – *Manchester*
K. Hadyńska, P. Napiórkowski – *Warsaw*

And to

- *FP7 SP2PP project*
- *Saint Gobain*
- *French ANR project*
- *Polish MNiSW Grant*



Lyon, 18 century