

Part 3 - L'interaction Nucléaire

L'interaction nucléaire

- interaction attractive forte, répulsive à très courtes distances
- courte portée
- indépendante du type de nucléon: n-n, n-p, p-p

Modern Nuclear Chemistry, W. Loveland et al.,

<i>A</i>	<i>Nucleus</i>	<i>Total Binding Energy (MeV)</i>	<i>Coulomb Energy (MeV)</i>	<i>Net nuclear binding energy (MeV)</i>
3	³ H	-8.486	0	-8.486
	³ He	-7.723	0.829	-8.552
13	¹³ C	-97.10	7.631	-104.734
	¹³ N	-94.10	10.683	-104.770
23	²³ Na	-186.54	23.13	-209.67
	²³ Mg	-181.67	27.75	-209.42
41	⁴¹ Ca	-350.53	65.91	-416.44
	⁴¹ Sc	-343.79	72.84	-416.63

L'interaction nucléaire

- dépendante des orientations & positions relatives des spin des nucléons

deuteron

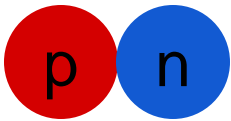

$J^\pi = 1^+$
 $\mu_d = 0.8574 \mu_N$ ($\mu_p = +2.7928 \mu_N$, $\mu_n = -1.9130 \mu_N$)
 faible moment quadripolaire électrique positif : $Q = 0.2859 e \cdot fm^2$

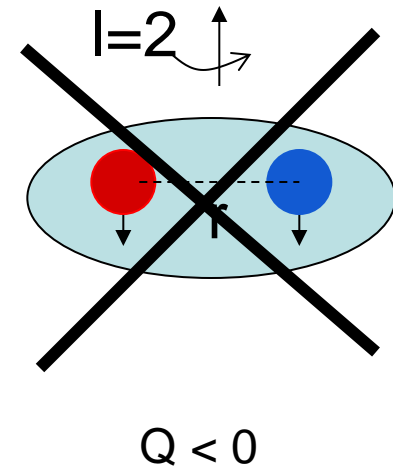
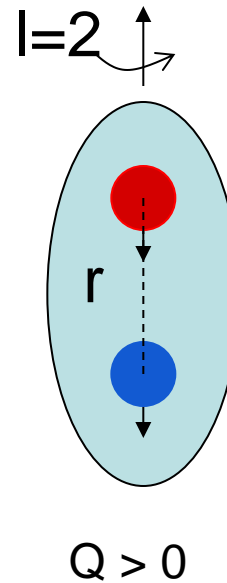
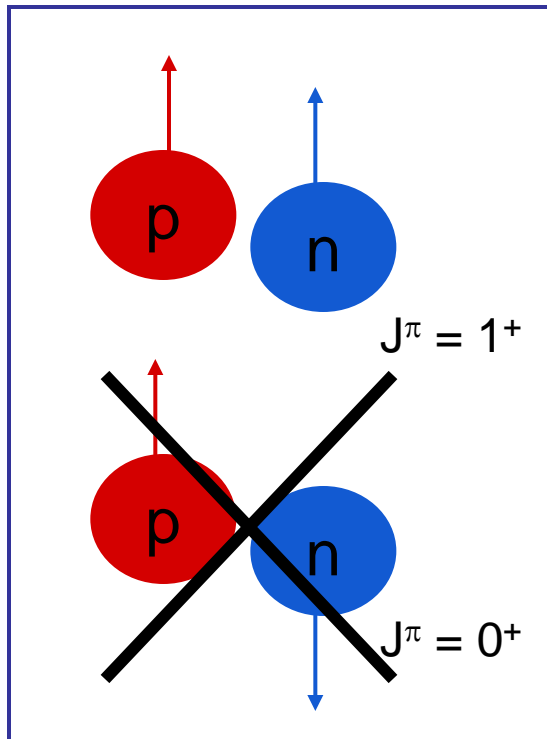

⇒ terme spin-spin et terme tenseur dans la force NN

La goutte liquide



similarité avec la force qui lie les molécules d'eau dans une goutte liquide

W. Heisenberg, Congrès de Solvay 1933 d'après une idée originale de G. Gamow (Proc. Roy. Soc. 126 (1930) 637)

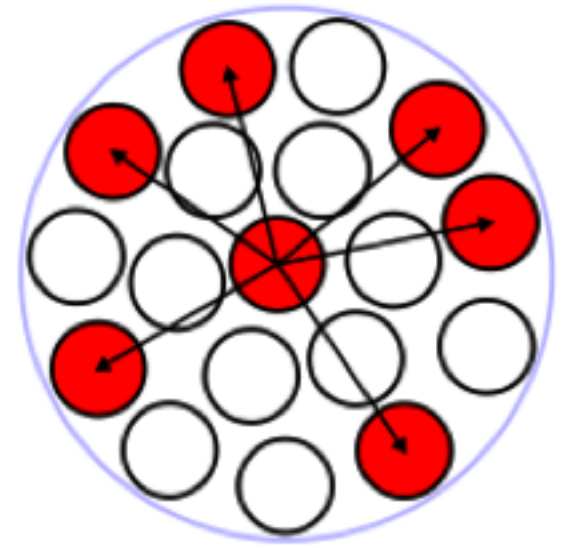
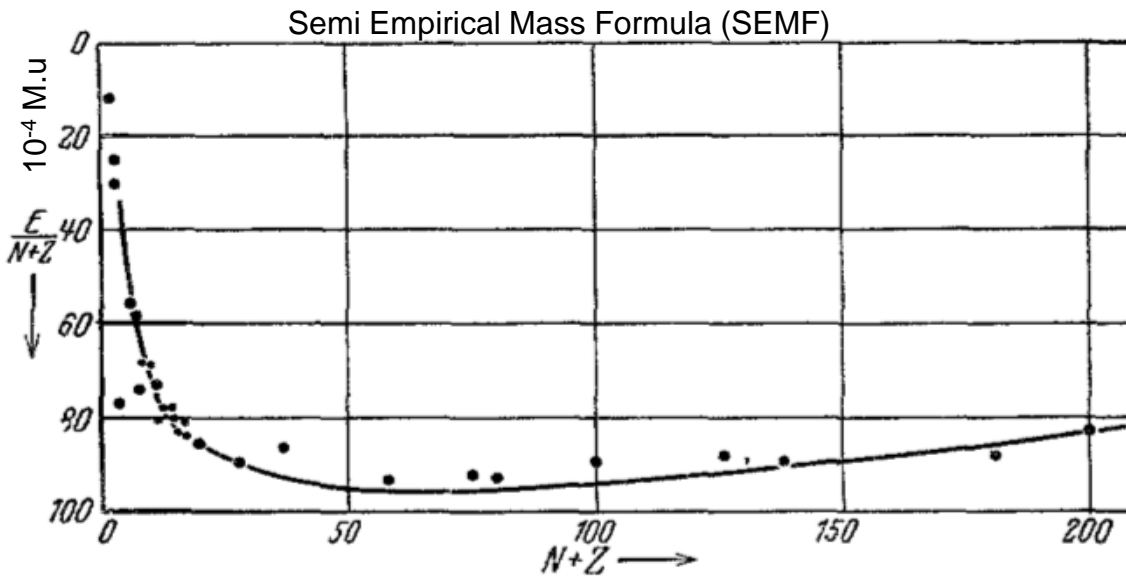

C.F. v. Weizsäcker, Z. Phys. 96 (1935) 431

Volume term	Surface term	Coulomb term	Asymmetry term	Pairing term
$a_v A$	$-a_s A^{2/3}$	$-a_c Z^2 A^{-1/3}$	$-a_a (A - 2Z)^2 A^{-1}$	$-\delta$

$$B(A, Z) = a_v A - a_s A^{2/3} - a_c Z^2 A^{-1/3} - a_a (A - 2Z)^2 A^{-1} - \delta$$

Termes d'asymétrie

Volume term	Surface term	Coulomb term	Asymmetry term	Pairing term
$a_v A$	$- a_s A^{2/3}$	$- a_c Z^2 A^{-1/3}$	$- a_a (A - 2Z)^2 A^{-1}$	$- \delta$

$$B(A, Z) = a_v A - a_s A^{2/3} - a_c Z^2 A^{-1/3} - a_a (A - 2Z)^2 A^{-1} - \delta$$

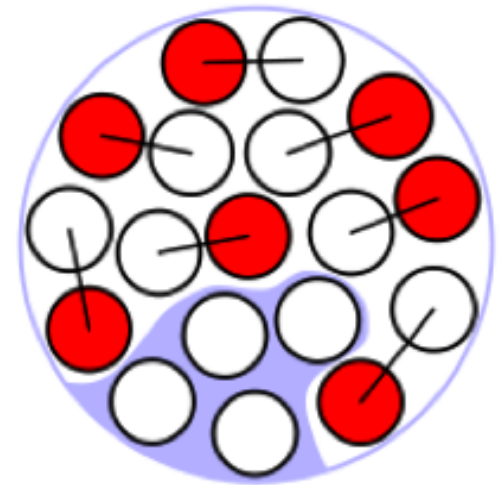
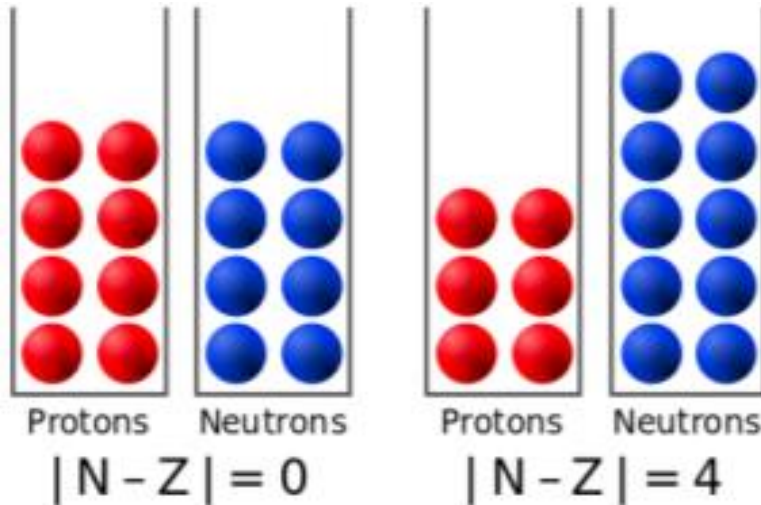

Terme d' appariement

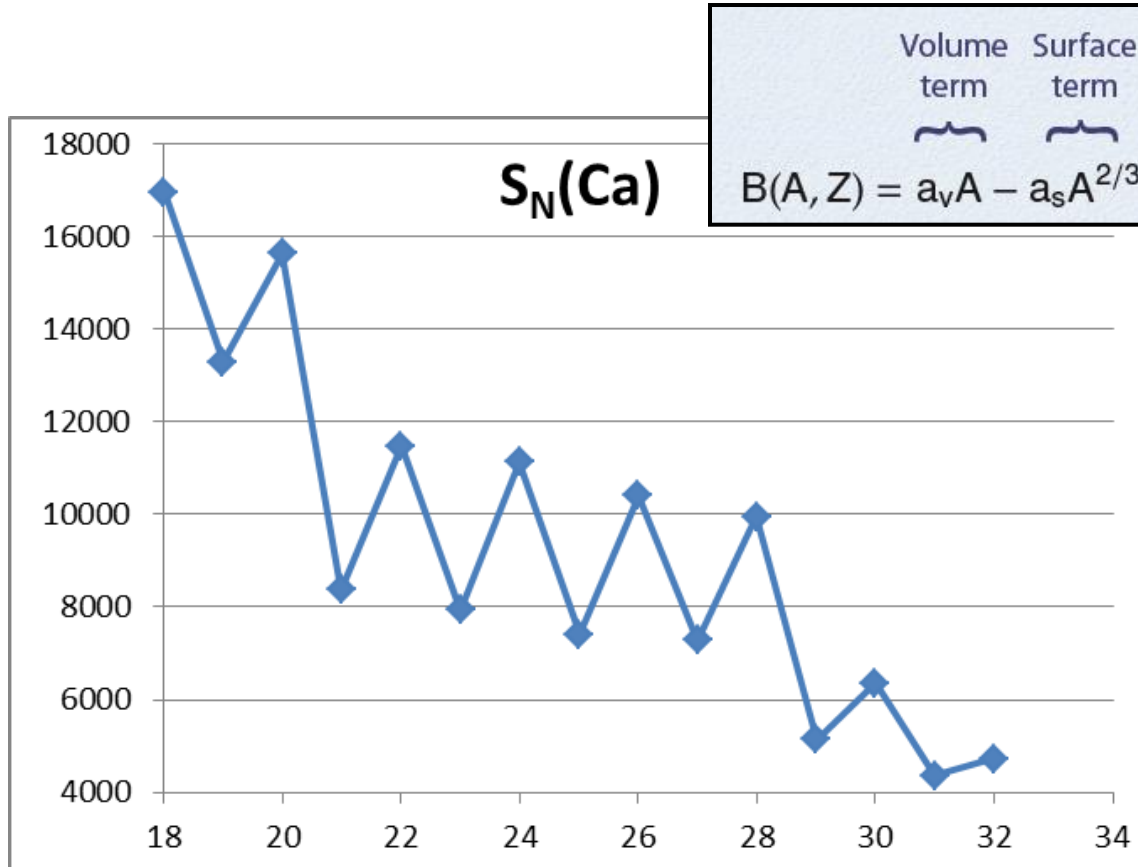

Volume term	Surface term	Coulomb term	Asymmetry term	Pairing term
$a_v A$	$-a_s A^{2/3}$	$-a_c Z^2 A^{-1/3}$	$-a_a (A - 2Z)^2 A^{-1}$	$-\delta$

$$B(A, Z) = a_v A - a_s A^{2/3} - a_c Z^2 A^{-1/3} - a_a (A - 2Z)^2 A^{-1} - \delta$$

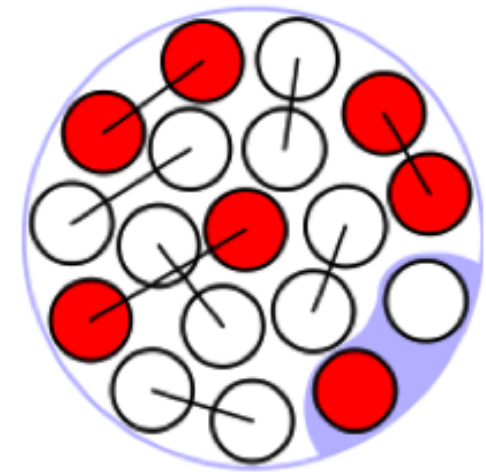

δ	$= +a_p A^{-1/2}$	for both N & Z odd
	$= 0$	for N even, Z odd / Z even, N odd
	$= -a_p A^{-1/2}$	for both N & Z even

Applications aux données

Wapstra (1971):

$$a_v = 15.85 \text{ MeV}$$

$$a_s = 18.34 \text{ MeV}$$

$$a_c = 0.71 \text{ MeV}$$

$$a_A = 23.21 \text{ MeV}$$

$$a_p = 12 \text{ MeV}$$

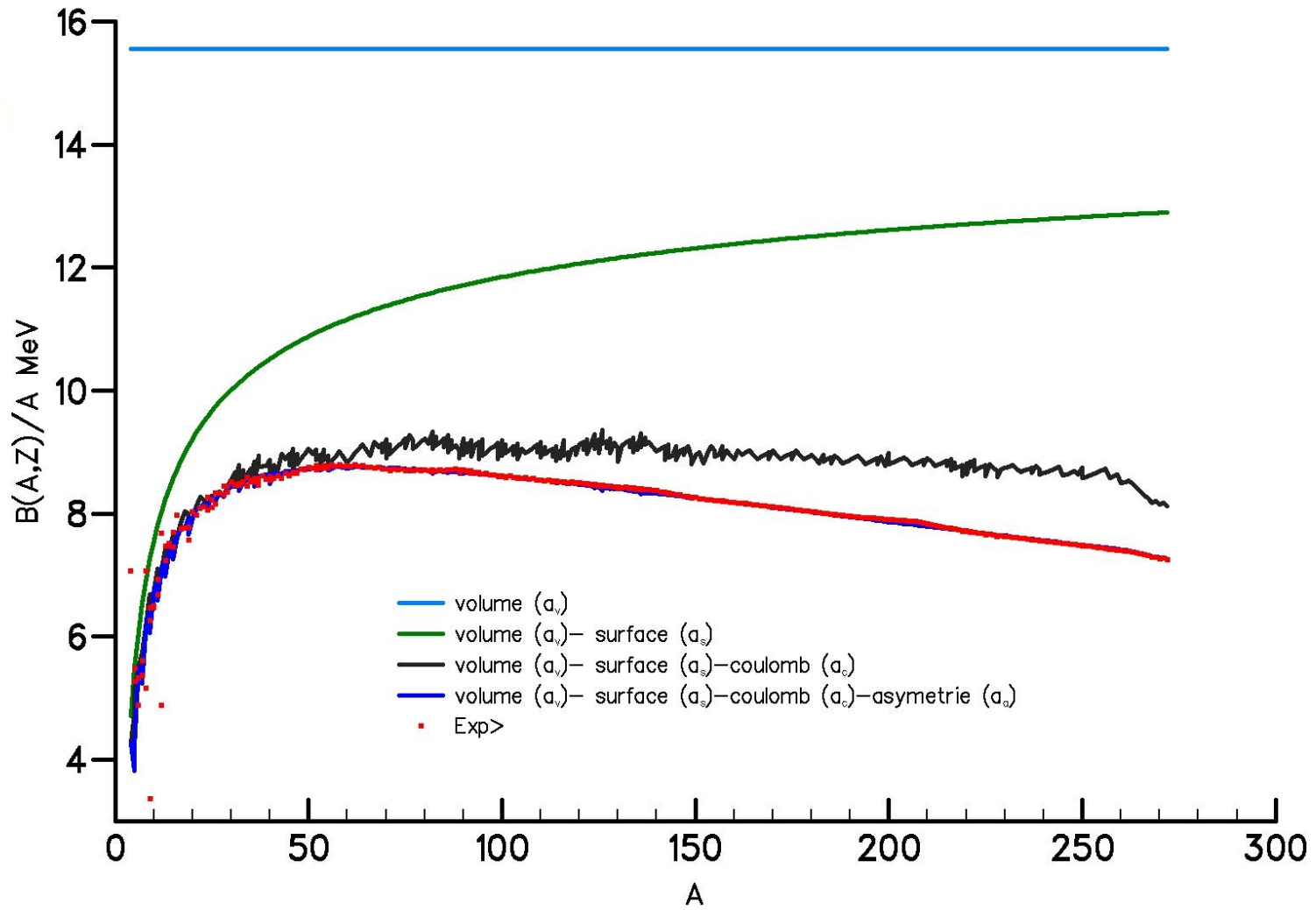

Stabilité de la goutte liquide

compétition entre la répulsion Coulombienne entre protons qui tend à déformer le noyau et la tension de surface qui tend à le maintenir sphérique

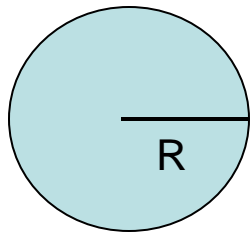

$$V = \frac{4}{3}\pi R^3$$

$$S = 4\pi R^2$$

$$-a_s A^{2/3} - a_c Z^2 A^{-1/3}$$

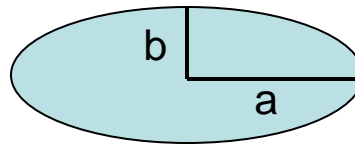

$$a = R(1 + \varepsilon)$$

$$b = R(1 + \varepsilon)^{-1/2}$$

$$V = \frac{4}{3}\pi a b^2$$

$$S = 4\pi R^2(1 + \frac{2}{5}\varepsilon^2 + \dots)$$

$$a_s A^{2/3}(1 + \frac{2}{5}\varepsilon^2 + \dots) - a_c Z^2 A^{-1/3}(1 - \frac{1}{5}\varepsilon^2 + \dots)$$

$$e = \sqrt{1 - \frac{b^2}{a^2}}$$

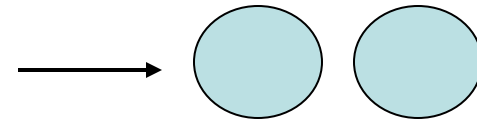

Si $\Delta \square = BE(\varepsilon) - BE(\varepsilon=0) > 0$ - c' est à dire $\frac{1}{5}a_c Z^2 A^{-1/3} > \frac{2}{5}a_s A^{2/3}$:
 \Rightarrow le noyau gagne de l' énergie en se déformant
 \Rightarrow fission spontanée

Stabilité de la goutte liquide

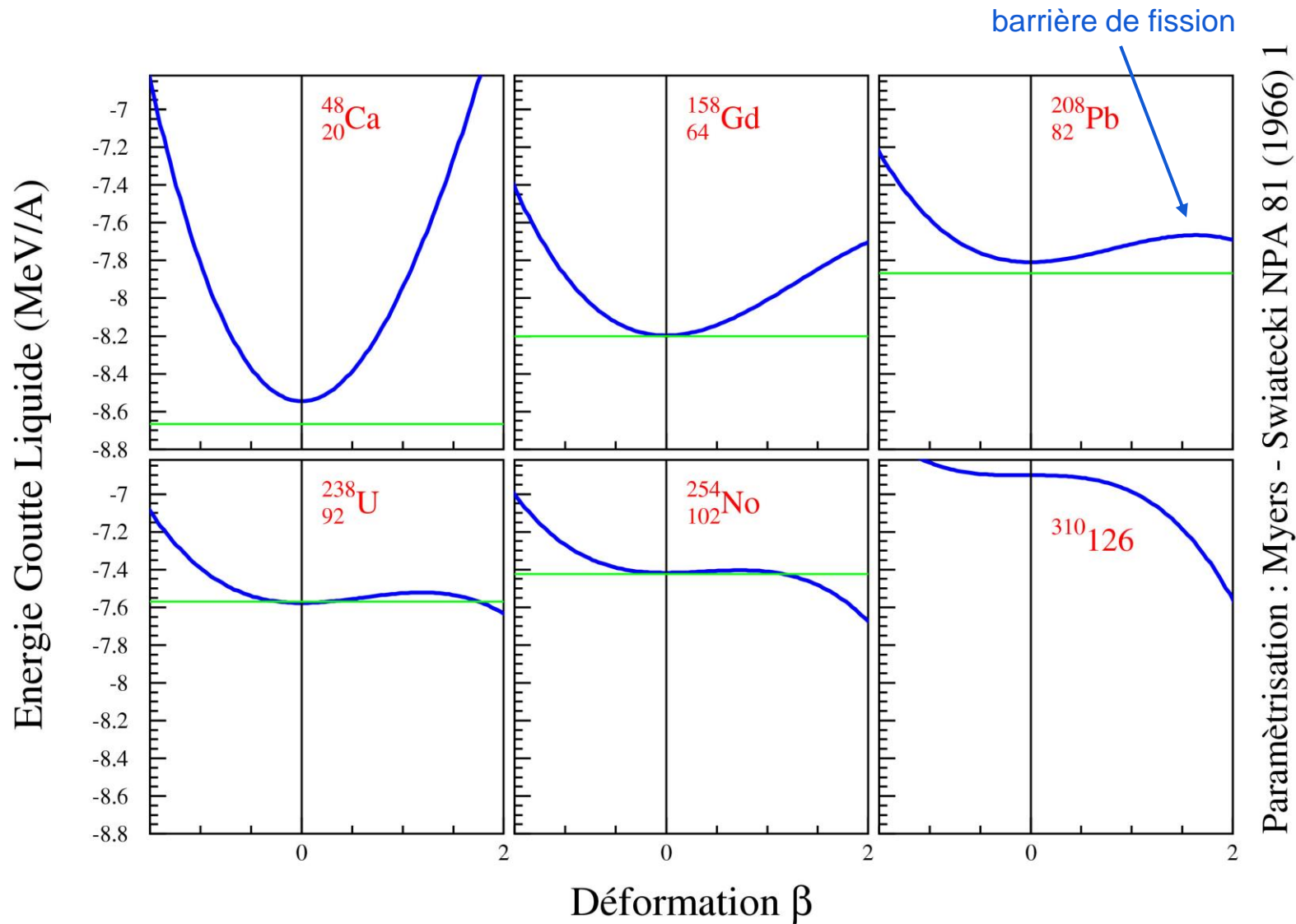

Correction d'effets de couches

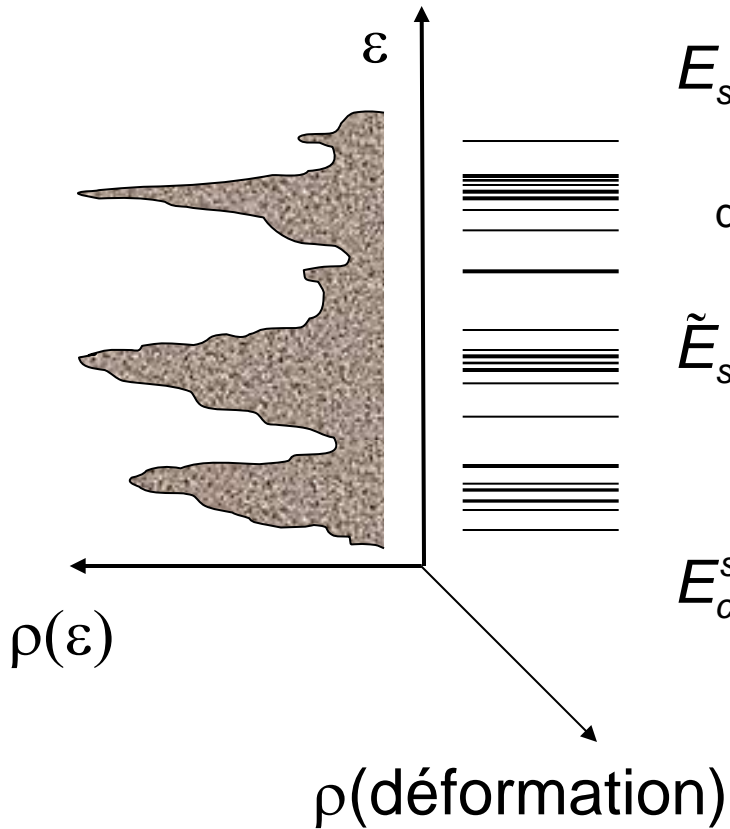

densité de niveaux individuels

$$E_{shell} = \int_{-\infty}^{e_F} r(e) de$$

densité de niveaux lissée

$$\tilde{E}_{shell} = \int_{-\infty}^{\tilde{e}_F} \tilde{r}(e) de$$

$$E_{shell}^{corr} = E_{shell} - \tilde{E}_{shell}$$

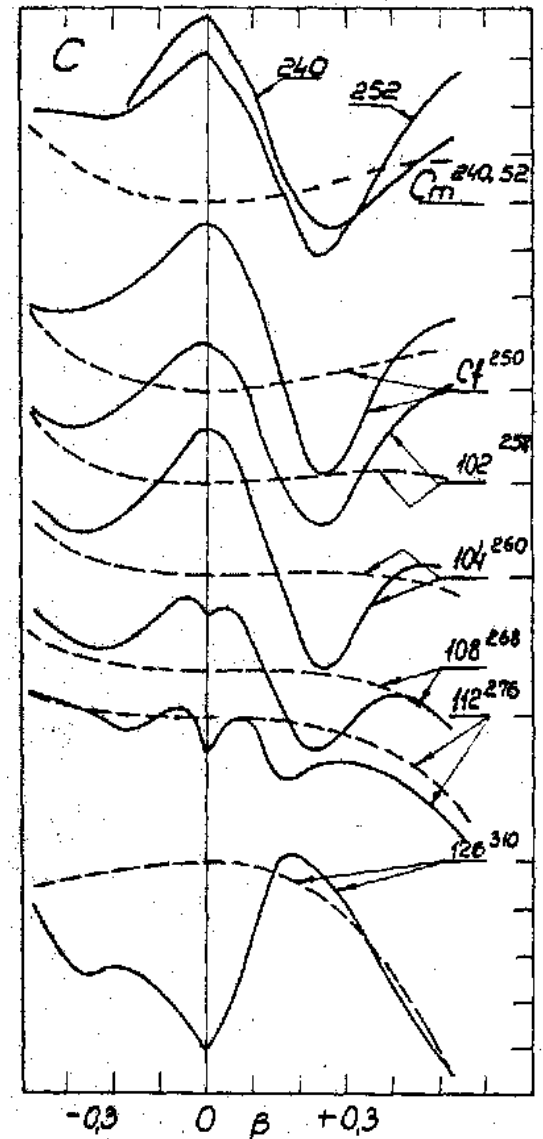

Radioactivité artificielle

1934 I. Curie et F. Joliot

découverte de la radioactivité artificielle

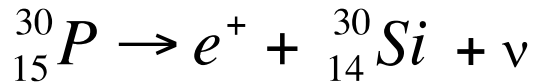
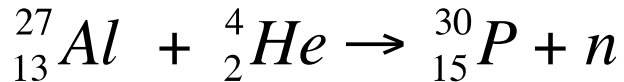

radio-phosphore !

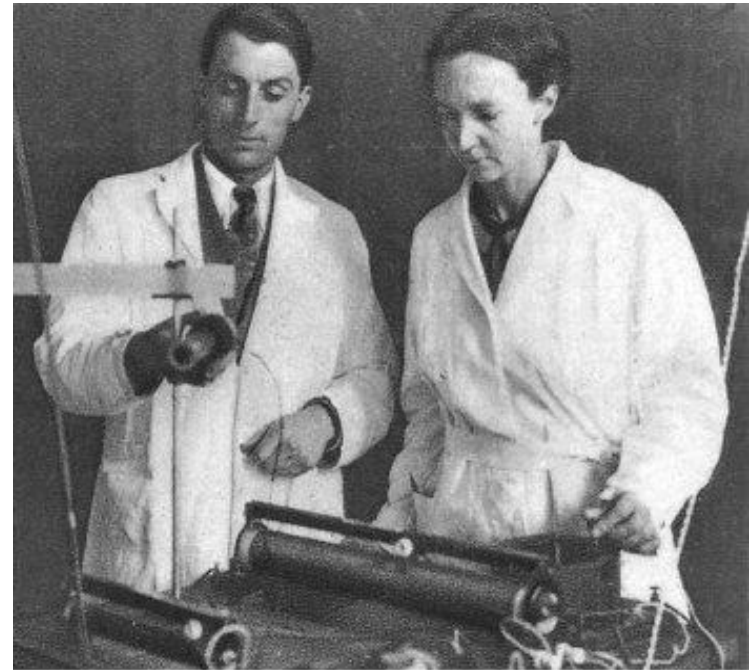

Irène Curie et
Frédéric Joliot

1936: John H. Lawrence est le premier à utiliser un radioélément artificiel à des fins thérapeutiques: ${}^{32}\text{P}$ pour traiter la leucémie

L'ère du neutron

1934 E. Fermi propose de bombarder des matériaux avec des neutrons

Il découvre que l'irradiation aux neutrons lents est plus apte à provoquer des transmutations

Son groupe découvre 40 nouveaux isotopes en 3 ans !

Il propose d'irradier des noyaux lourds pour synthétiser des éléments transuraniens et pense avoir découvert les éléments $Z=93$ et 94 (Ausonium et Hesperium)

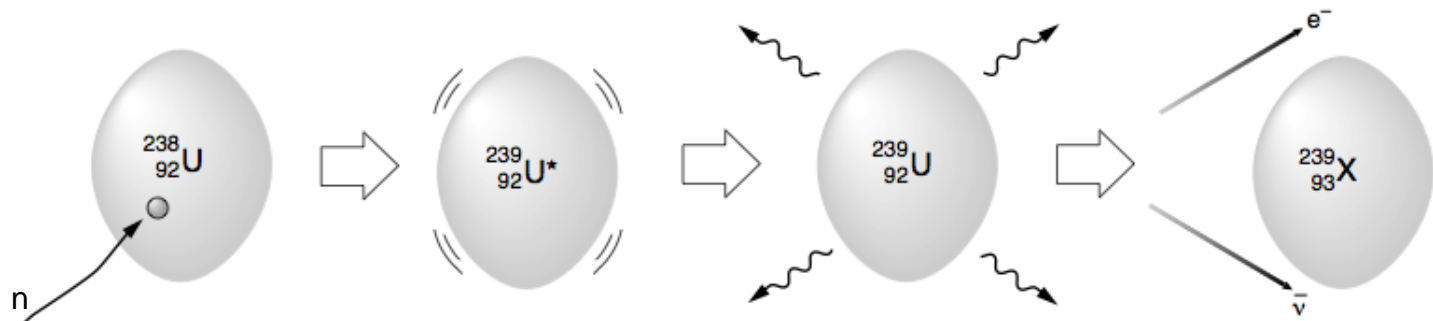

La quête des transuraniens...

1935-1938: Otto Hahn, Lise Meitner et Fritz Strassmann comptabilisent plus de 10 nouveaux radio-isotopes transuraniens (jusqu'à $Z=96$)

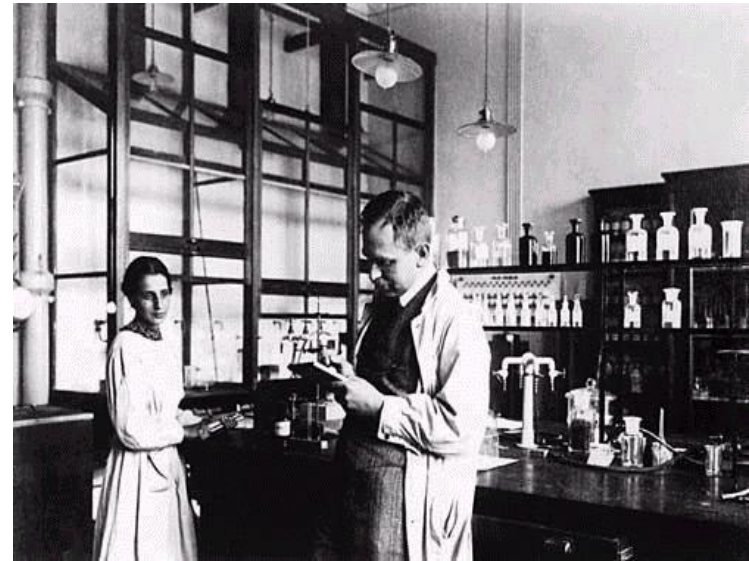

Lise Meitner et Otto Hahn (1918)

“Nous devons appeler Baryum, Lanthane et Cerium ce que nous avons appelé précédemment Radium, Actinium et Thorium. C’est une décision difficile qui contredit toutes les expériences de physique nucléaire menées jusqu’à présent.”

La fission

1939: L. Meitner donne une explication à cette découverte avec son neveu Otto Frisch: **la fission** de l'uranium

L. Meitner and O. Frisch, Nature 143 (1939) 239

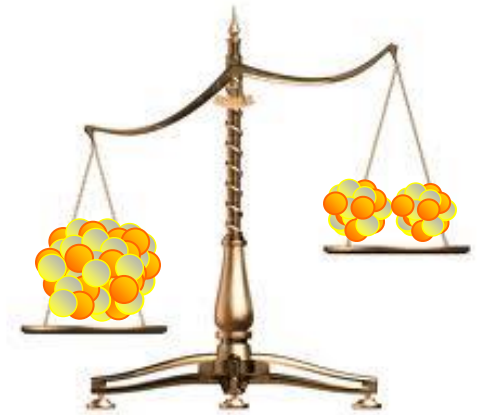
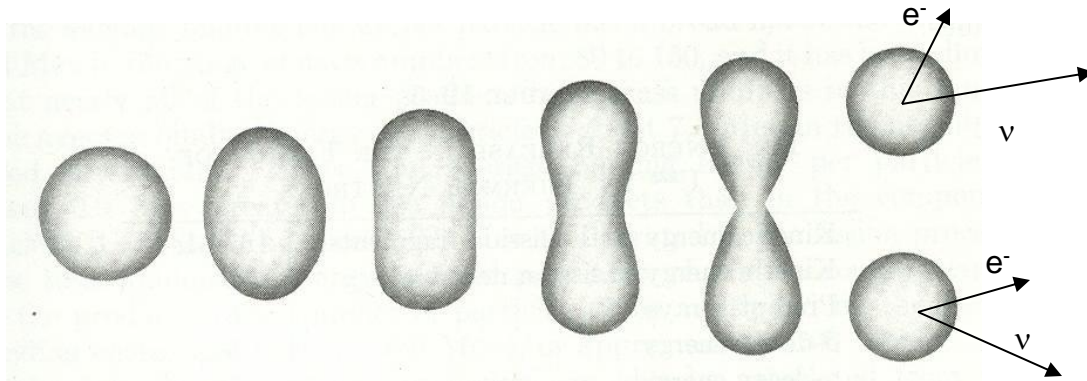

L'hypothèse est tout de suite confirmée expérimentalement par O. Frisch puis par d'autres (F. Joliot)

O. Frisch, Nature 143 (1939) 276

N. Bohr et J.A. Wheeler élaborent une théorie de la fission basée sur la goutte liquide

N. Bohr et A. Wheeler, Phys. Rev. 56 (1939) 426

Propriétés de la fission

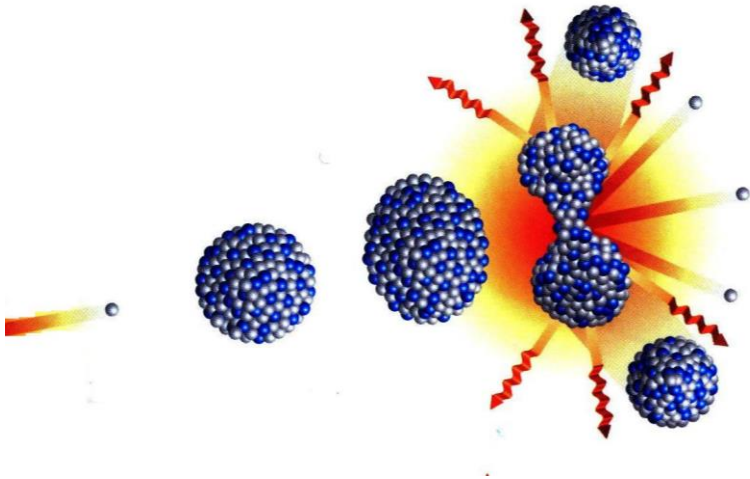

Chaque fission de l'Uranium produit des neutrons

Hans Von Halban, Frédéric Joliot et Lew Kowarski, Nature 143 (1939) 470

F. Joliot voit la possibilité d'une réaction en chaîne

Francis Perrin introduit la notion de masse critique et de modérateur

Des brevets sont déposés

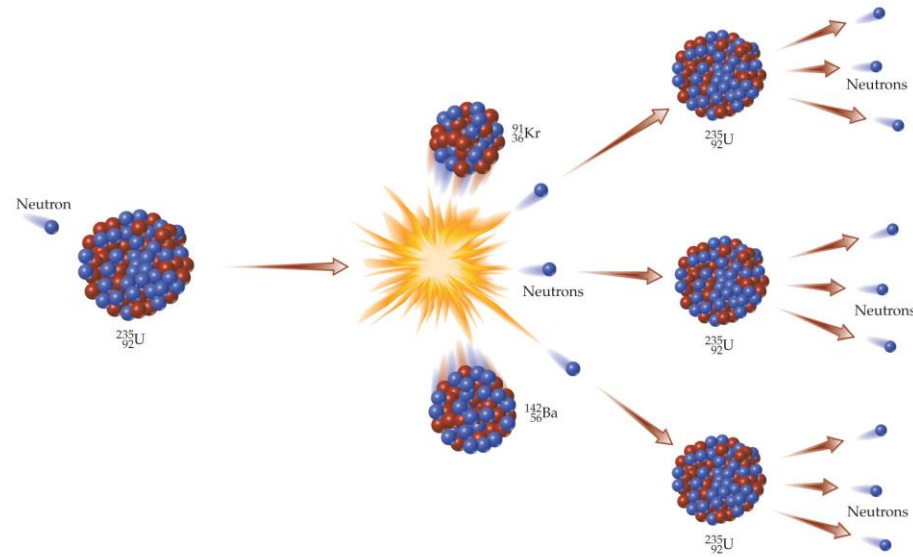

Copyright © 2007 Pearson Prentice Hall, Inc.

Le projet Manhattan et C_{hicago}P_{ile}-1

Leo Szilard fait signer à A. Einstein une lettre au président Franklin D. Roosevelt en 1939 sur la possibilité d'une bombe atomique.



La première pile atomique est inaugurée en décembre 1942

La réaction en chaîne est maintenue pendant 28 minutes

La fission pour la guerre et la paix....

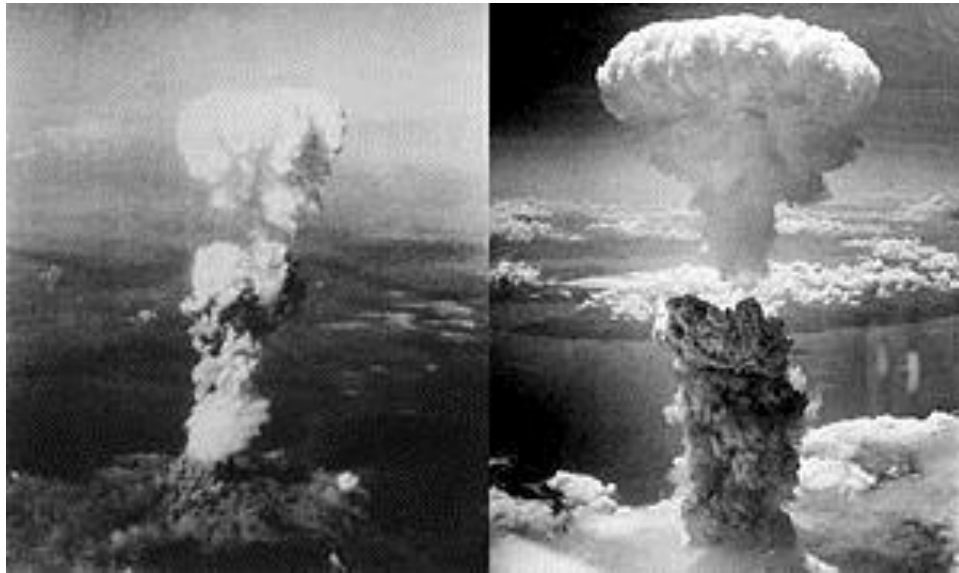

Hiroshima et Nagasaki les 6 et 9 Août 1945

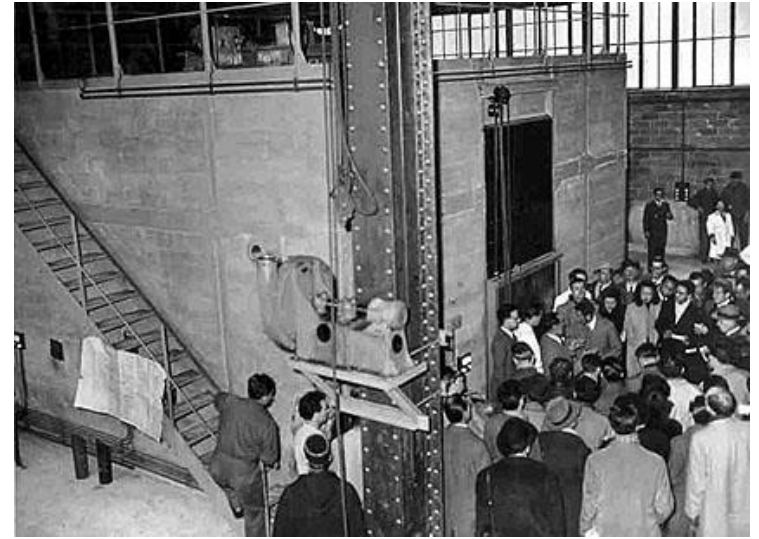

1948: Inauguration de la première pile atomique française: ZOE



1951: Première production d'électricité nucléaire à EBR-I dans l'Idaho (USA)

1954: Premiers kWh d'une centrale nucléaire: Obninsk AES-1 (URSS)



Nouvelles décou

1940: G. Flerov et K. Petrzak découvrent la fission spontanée en travaillant sur des noyaux d'Uranium

beta + proton \rightarrow neutron
+ particules légères

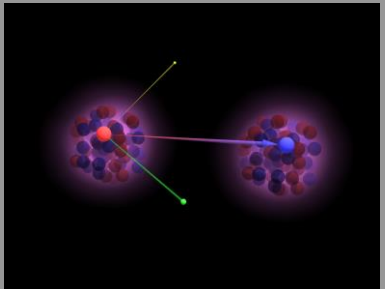

alpha émission ^4He

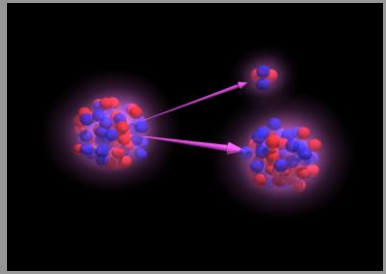

fission cassure du noyau
 \rightarrow 2 noyaux plus légers

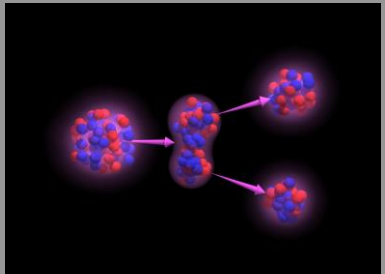

beta - neutron \rightarrow proton
+ particules légères

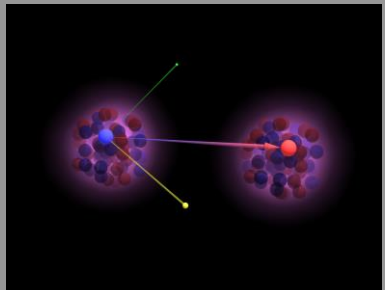

Gamma réarrangement
nucléaire + rayon gamma

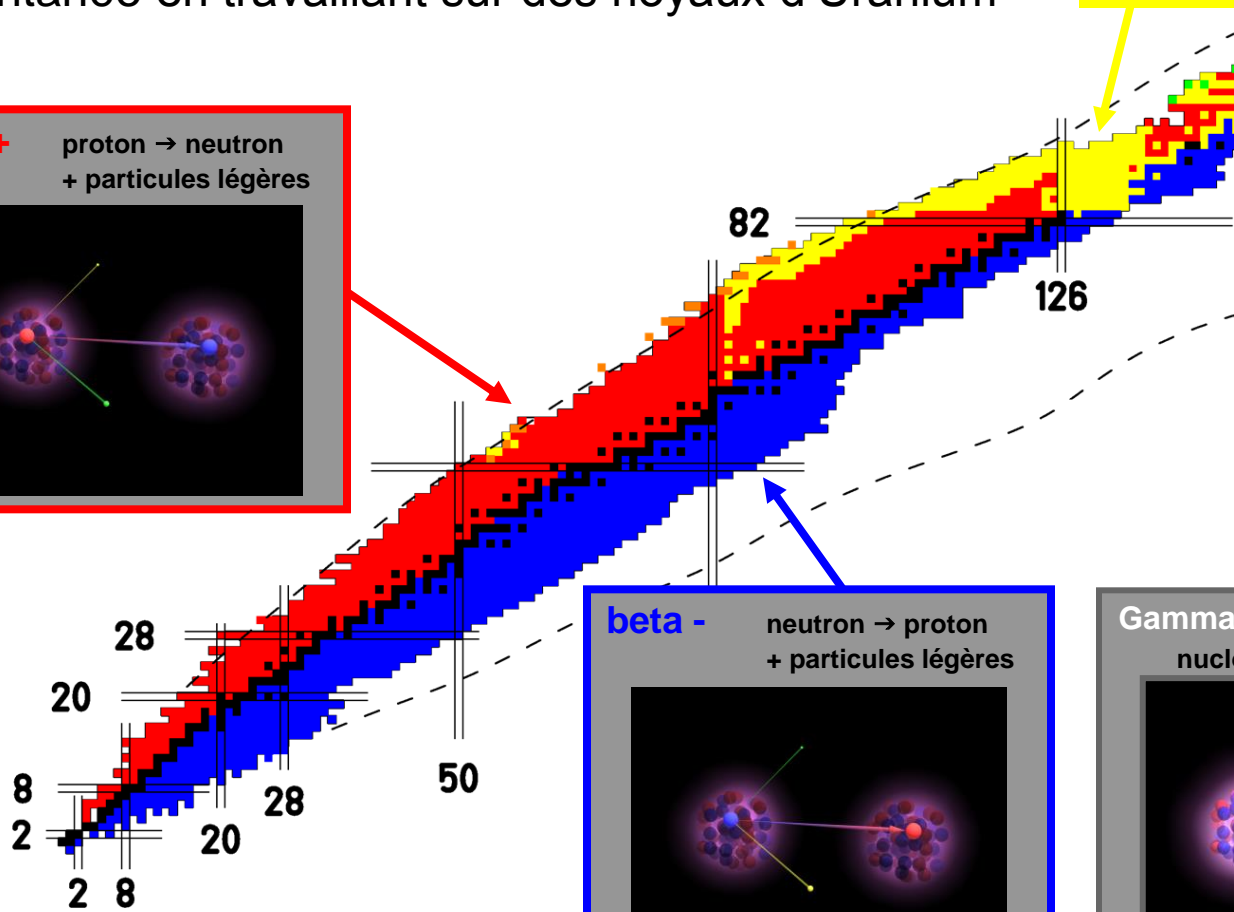
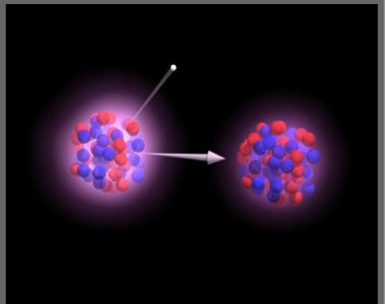

Nombres Magiques



Maria G.
Mayer

M. Goeppert Mayer remarque que les noyaux ayant un nombre de neutrons et/ou de protons égal à 2, 8, 20, 50, 82, 126 sont relativement plus abondants que leurs voisins

Les noyaux associés à ces nombres sont également particulièrement liés et génèrent des discontinuités par rapport à l'énergie de la goutte liquide

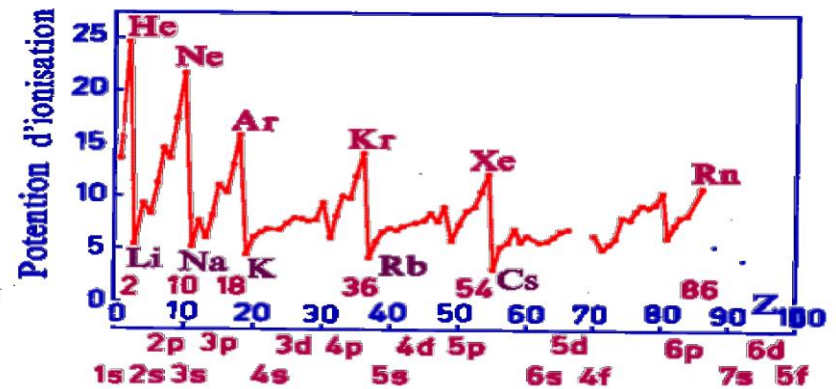
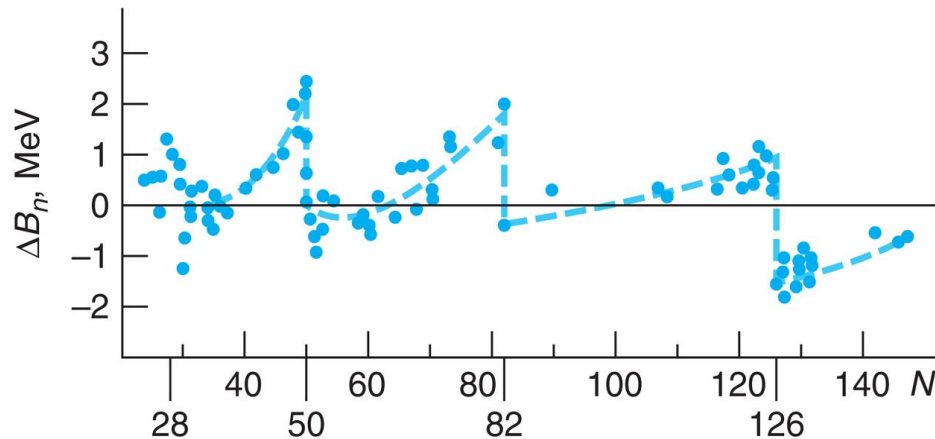

⇒ structure périodique dans le noyau ?

'On closed shells in nuclei', M G. Mayer *Phys. Rev.* 74 (1948) 235

La mécanique quantique ne reproduit pas ces nombres au delà de 20 ...

potentiel nucléaire moyen ressenti par les nucléons



niveaux d'énergie

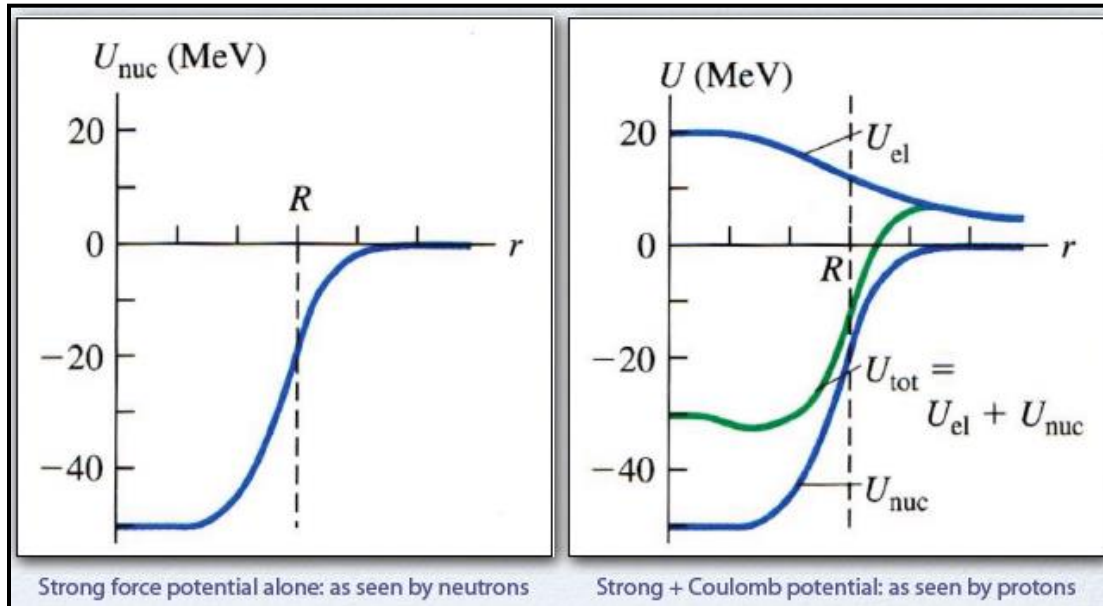

2p	=====	6	40
1f	=====	14	
2s	=====	2	20
1d	=====	10	
1p	●●●●●●	6	8
1s	●●	2	2

Nombre total de neutrons (ou protons) que peuvent accommoder les couches:

2, 8, 20, 40, 58, 92, 138

La question qui fait tilt !

Thanks are due to Enrico Fermi for the remark, "Is there any indication of spin-orbit coupling?" which was the origin of this paper.

'On closed shells in nuclei. II',
M. G. Mayer Phys. Rev. 75 (1949) 1969

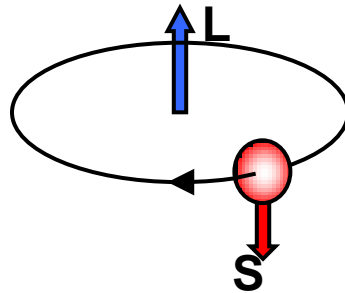

Hans Jensen

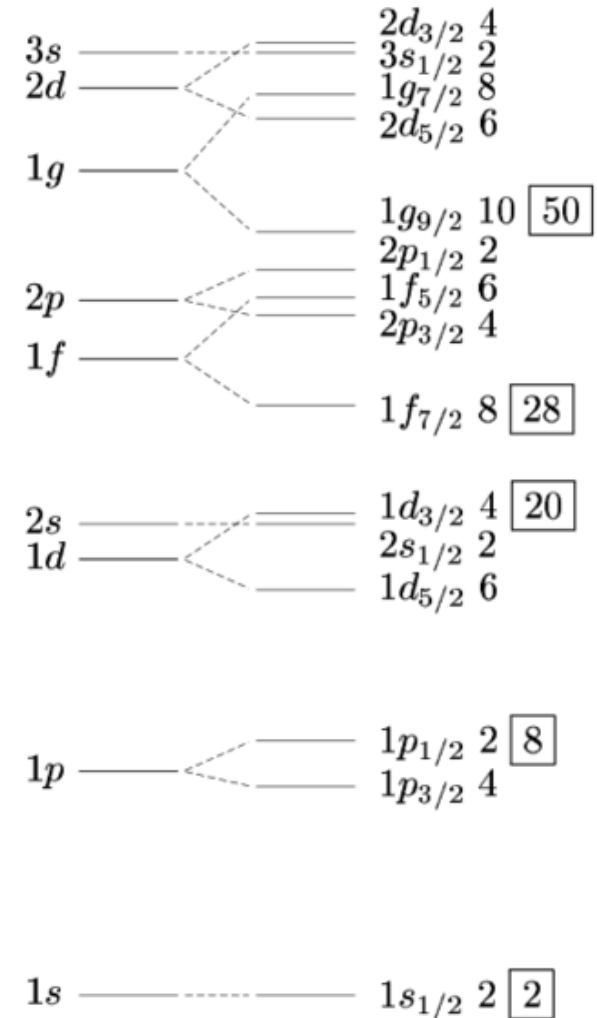
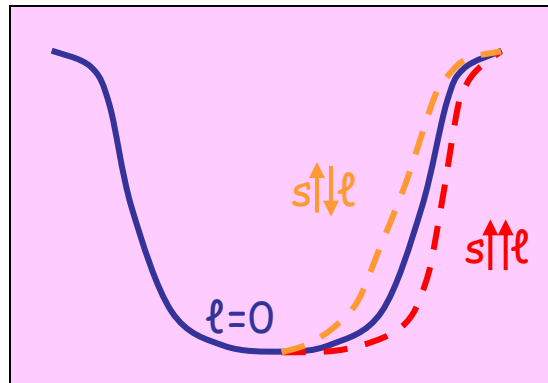

Succès du modèle en couches

propriétés des noyaux magiques:

- * $J^\pi=0^+$
- * énergie élevée du premier état excité
- * faible probabilité d'excitation

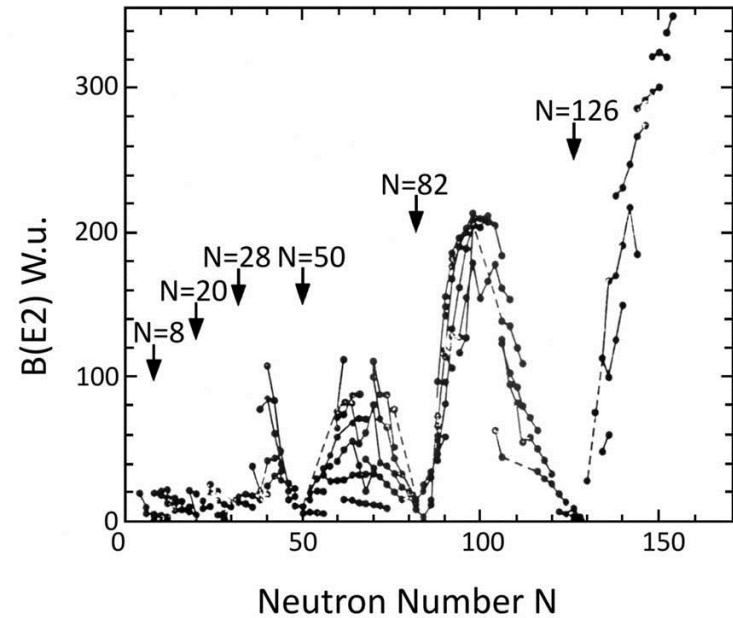

propriétés des noyaux ayant 1 nucléon de + ou de - que les noyaux magiques:

* $J^\pi(\text{noyau}) = J^\pi(\text{dernier nucléon/trou})$

^{17}O :

- état fondamental: $5/2^+$
- premier état excité: $1/2^+$

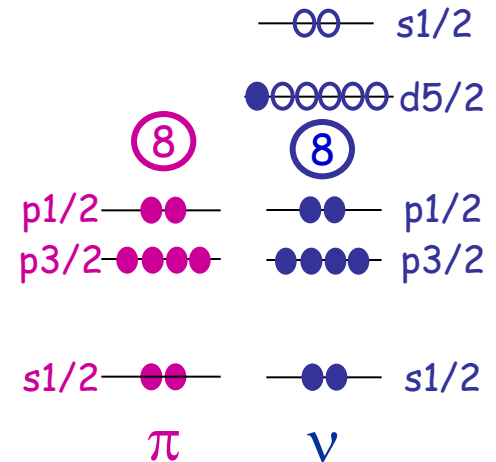

Moments magnétiques nucléaires

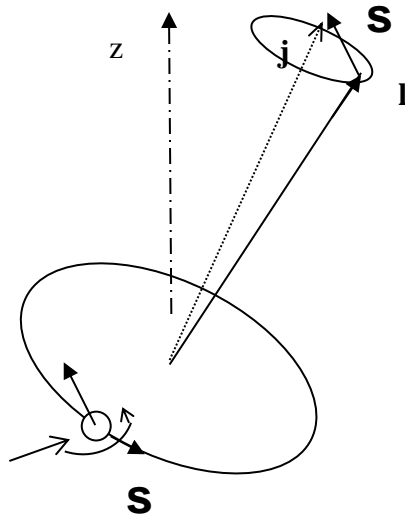

proton
ou neutron

$$\vec{\mu} = g^l \vec{l} + g^s \vec{s}$$

Lignes de Schmidt

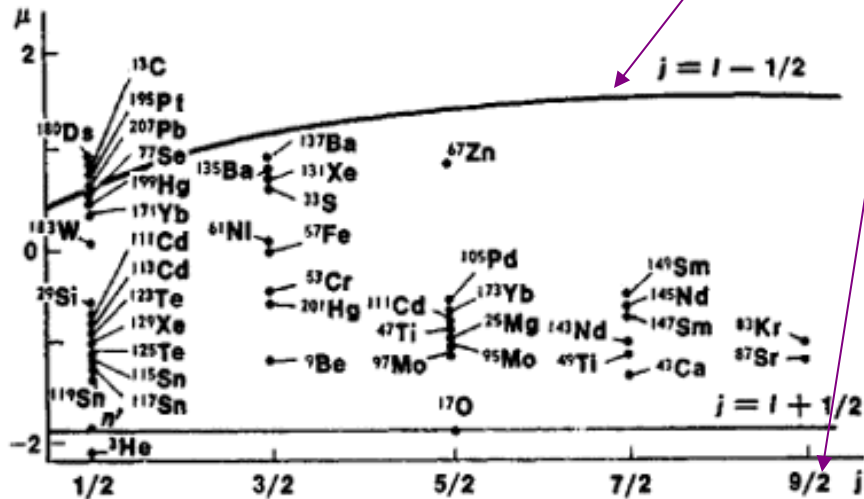

neutron célibataire

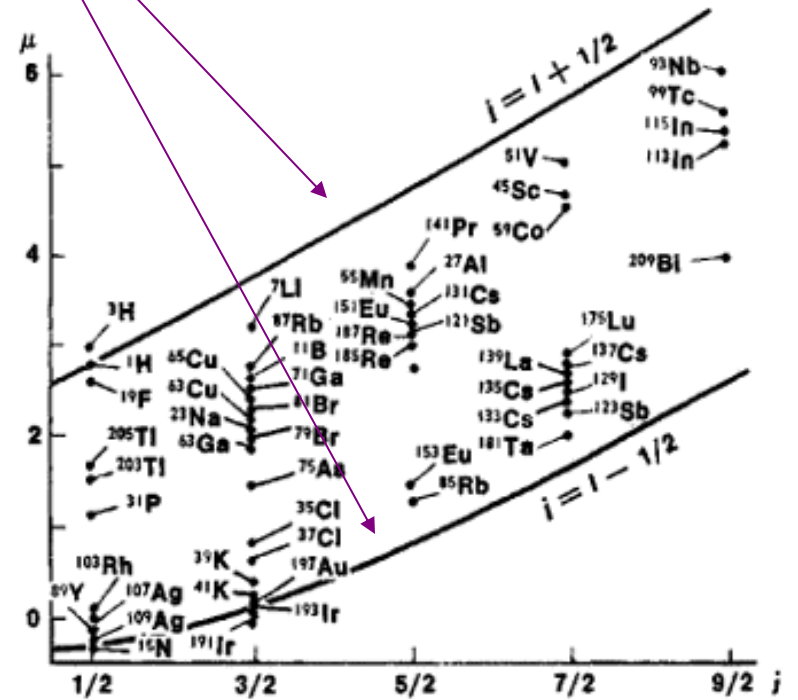

proton célibataire

Moment quadropolaire électrique

'oblate'

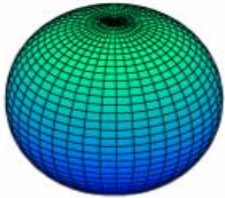

$$Q < 0$$

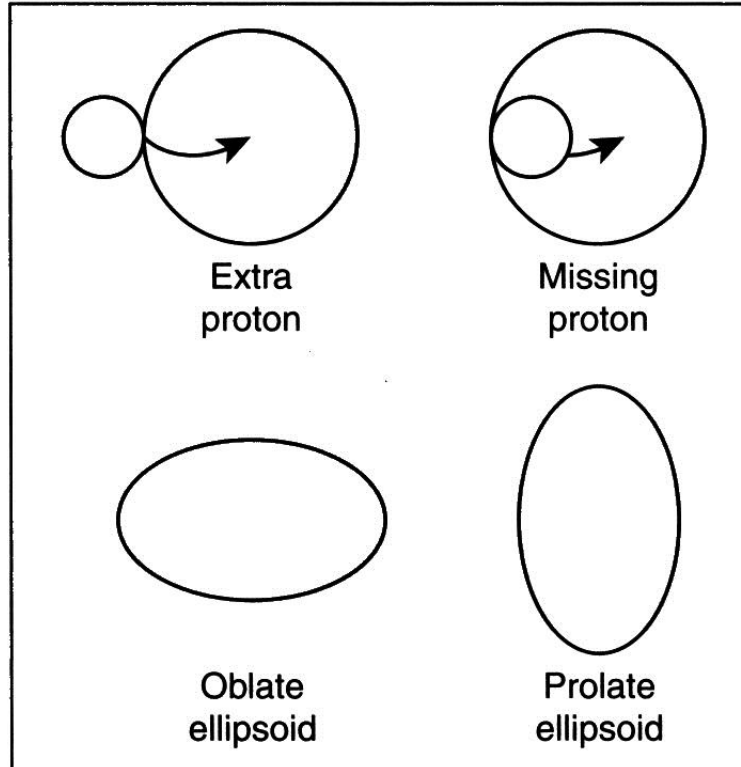

'prolate'

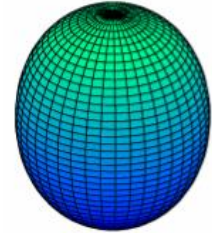

$$Q > 0$$

$$\langle Q \rangle = -\frac{2j-1}{2(j+1)} \langle r_j^2 \rangle$$

$$\langle Q \rangle(\text{trou}) = -\langle Q \rangle(\text{particule})$$

Distributions de charge expérimentales

C.H. Townes et al., Phys. Rev. 76 (1949) 1415

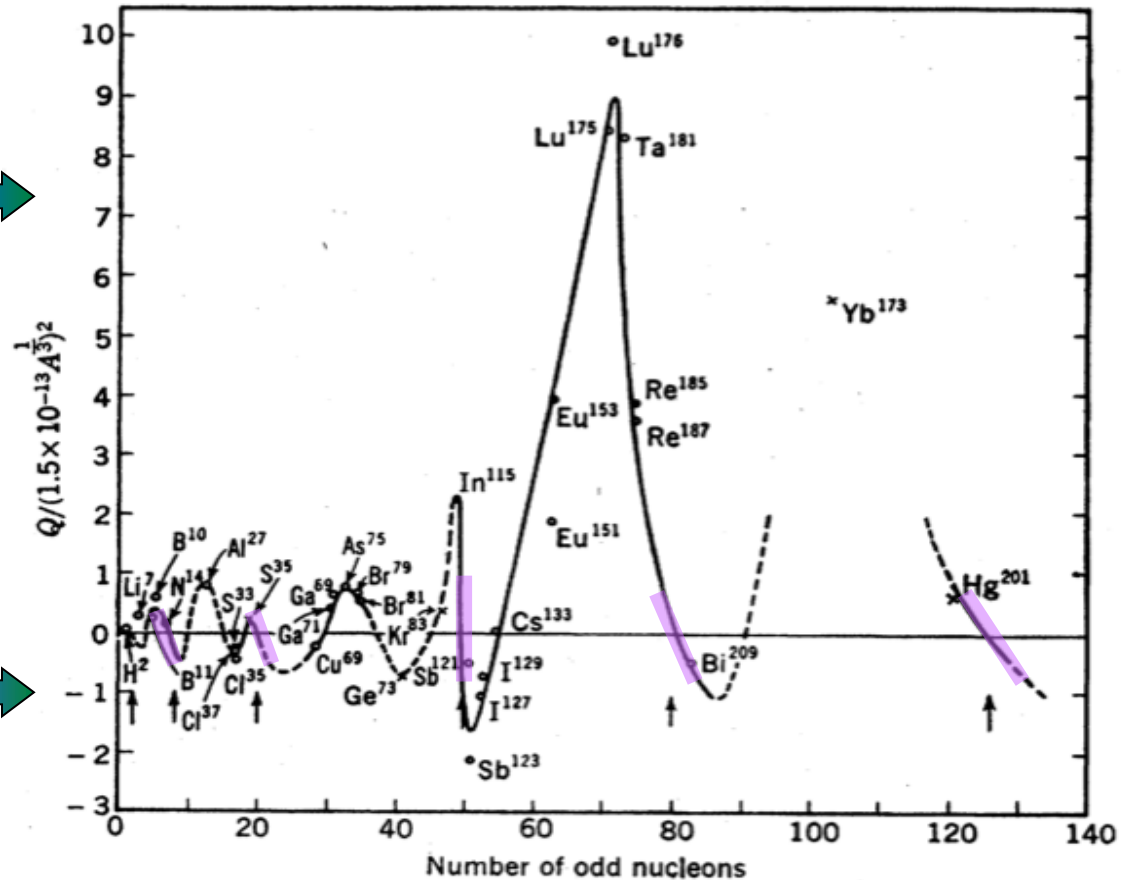
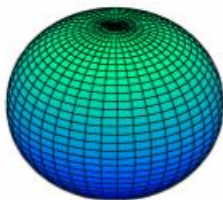
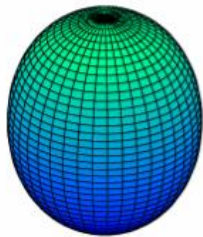

Certains moments sont jusqu'à 30 fois plus élevés que les prédictions !

Et si le noyau gagnait à se déformer....?



James Rainwater

Distorsion de la goutte liquide sous l'influence des trajectoires des nucléons de valence pour gagner en stabilité

J. Rainwater, Phys. Rev. 79 (1950) 432

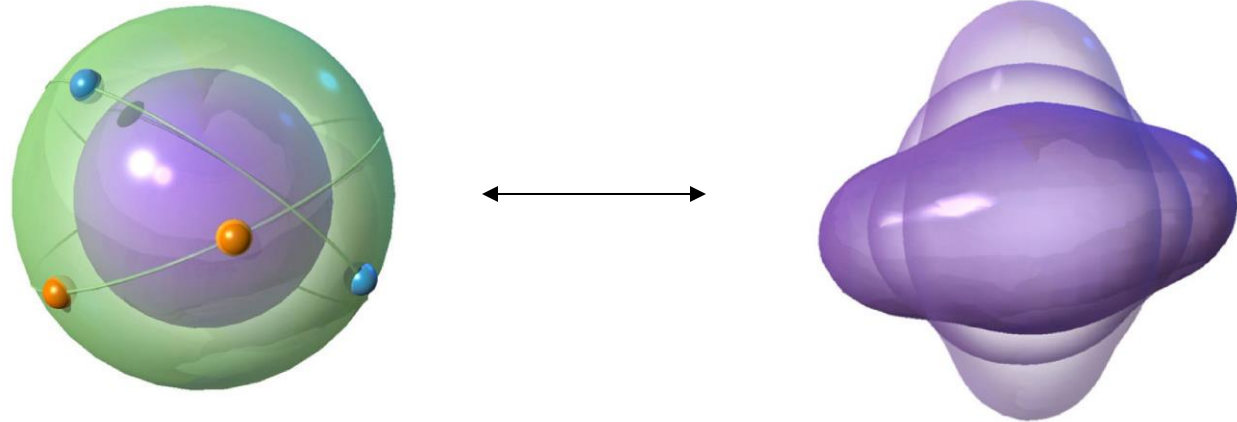

Etats individuels et collectifs du noyau

Le modèle unifié couple les oscillations et rotations de la goutte aux mouvements des nucléons individuels

A. Bohr et B. Mottelson, Kgl. Danske Videnskab. Selskab, Mat.-fys. Medd. 27 (1953) 16

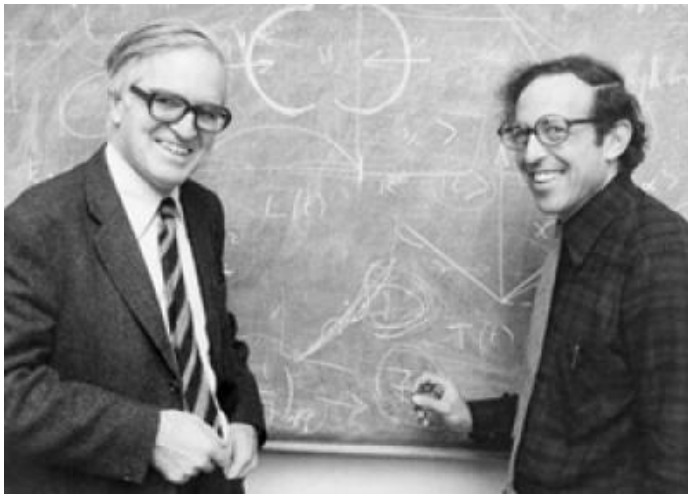

Aage Bohr et Ben Mottelson

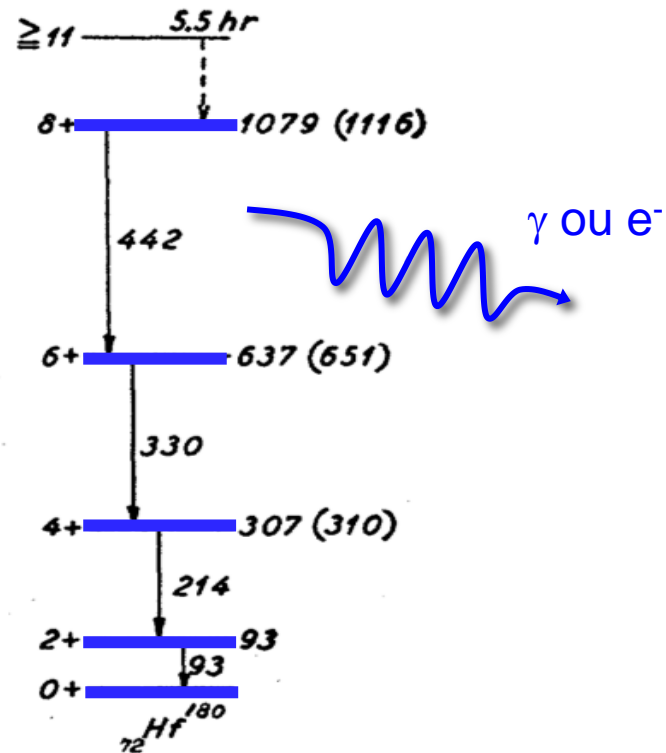
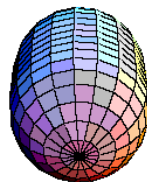
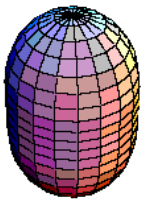

Le potentiel déformé de Nilsson

S. G. Nilsson *Mat. Fys. Medd. Dan. Vid. Selsk.* **29** no 16 (1955)

$$H = \frac{\mathbf{p}^2}{2m} + \frac{m[\omega_x^2(x^2 + y^2) + \omega_z^2 z^2]}{2} + C\mathbf{l} \cdot \mathbf{s} + D\mathbf{l}^2$$

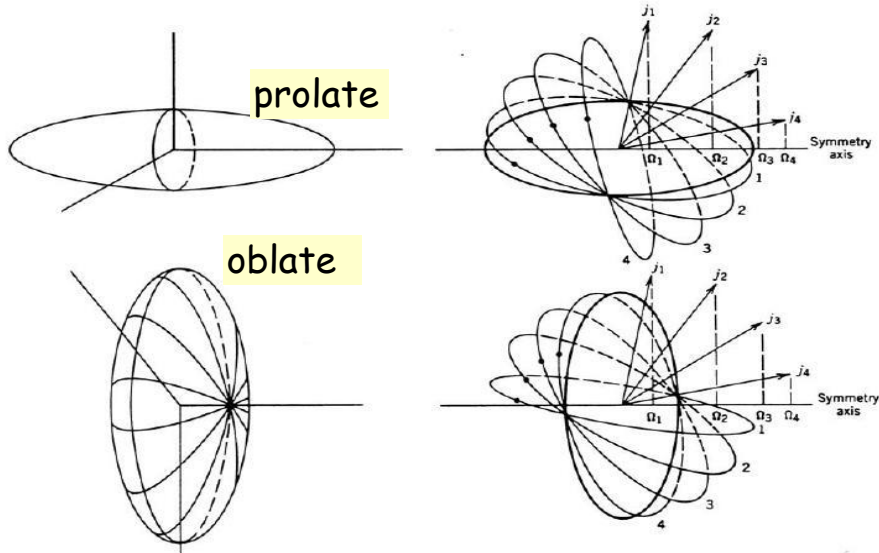

$^{21}\text{Ne}_{11}$ and $^{21}\text{Na}_{10}$

	g.s.	first E^*
• spherical SM	$5/2^+$	$1/2^+$
• experiment	$3/2^+$	$5/2^+$

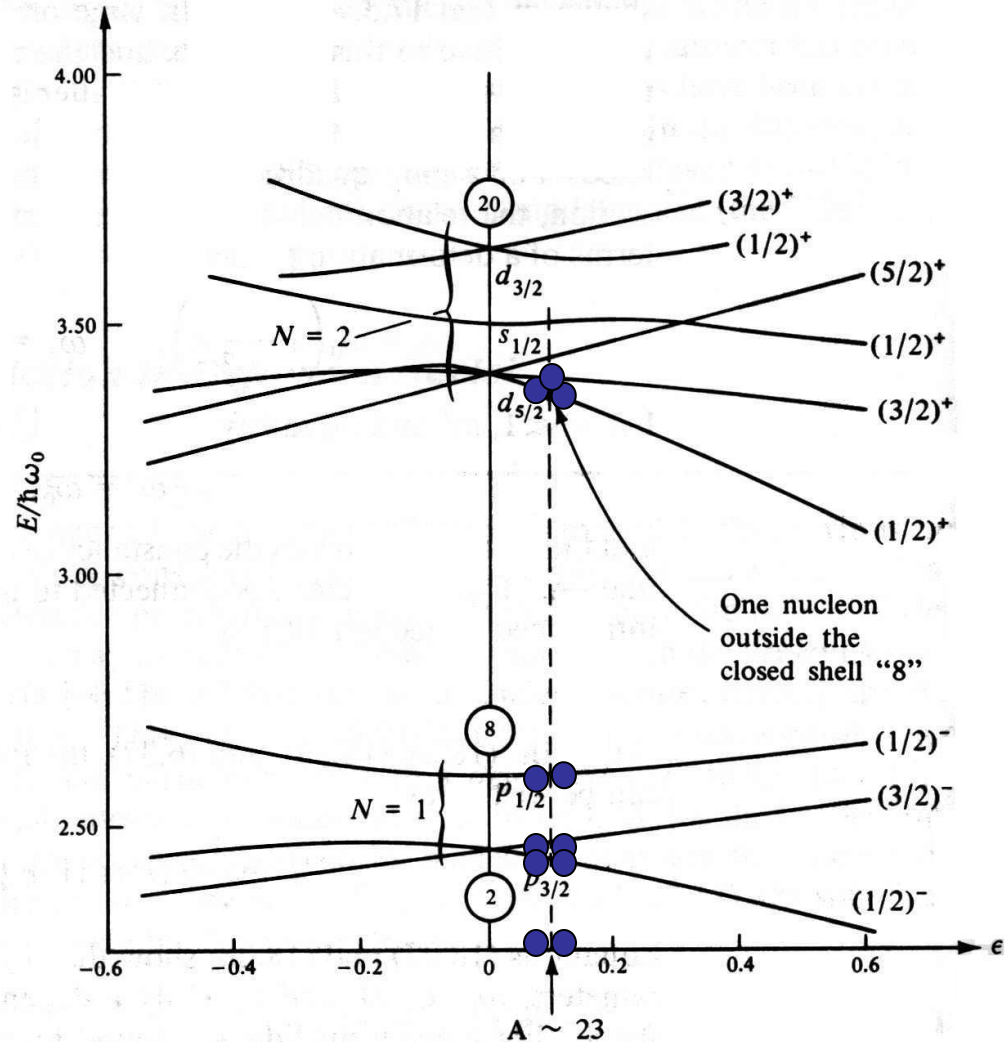

Approches auto-cohérentes

but: déduire le potentiel nucléaire à partir de l'interaction NN

procédure itérative car le potentiel issu de toutes les interactions à 2 corps possibles dépend des fonctions d'onde qu'on cherche à déterminer

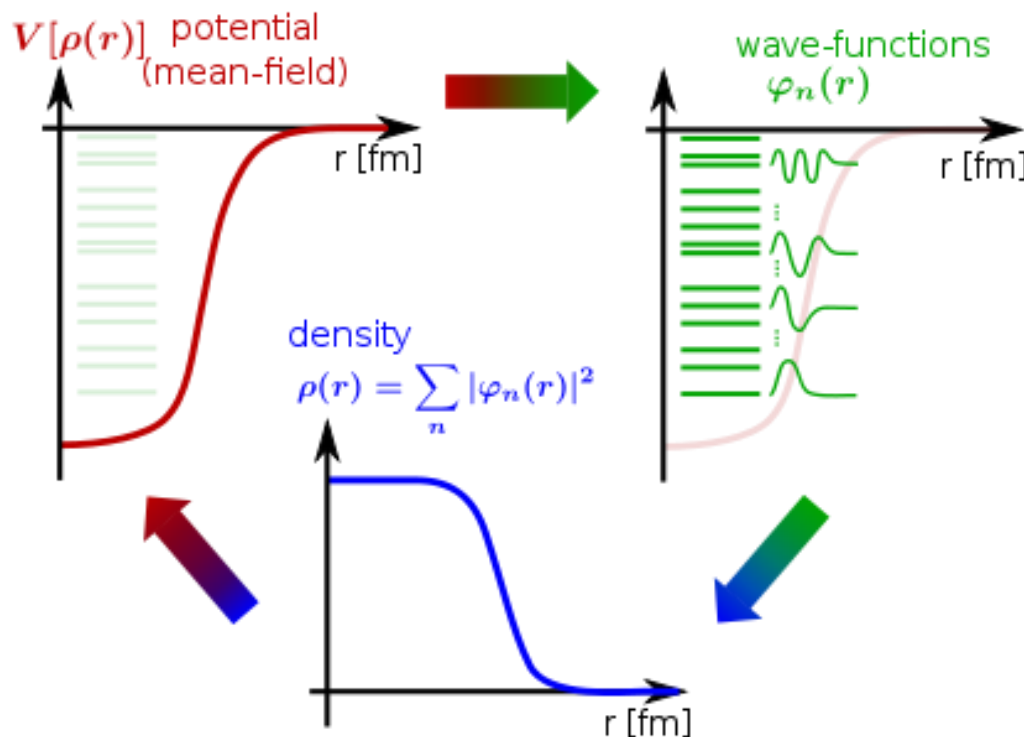

- Exemples d'interactions:
- **Skyrme** (force de contact)
 - **Gogny** (portée finie)

Self-consistent mean-field theory

Développements techniques des années 1950-70

Détecteurs scintillateurs puis semi-conducteurs



Accélérateurs d'ions lourds

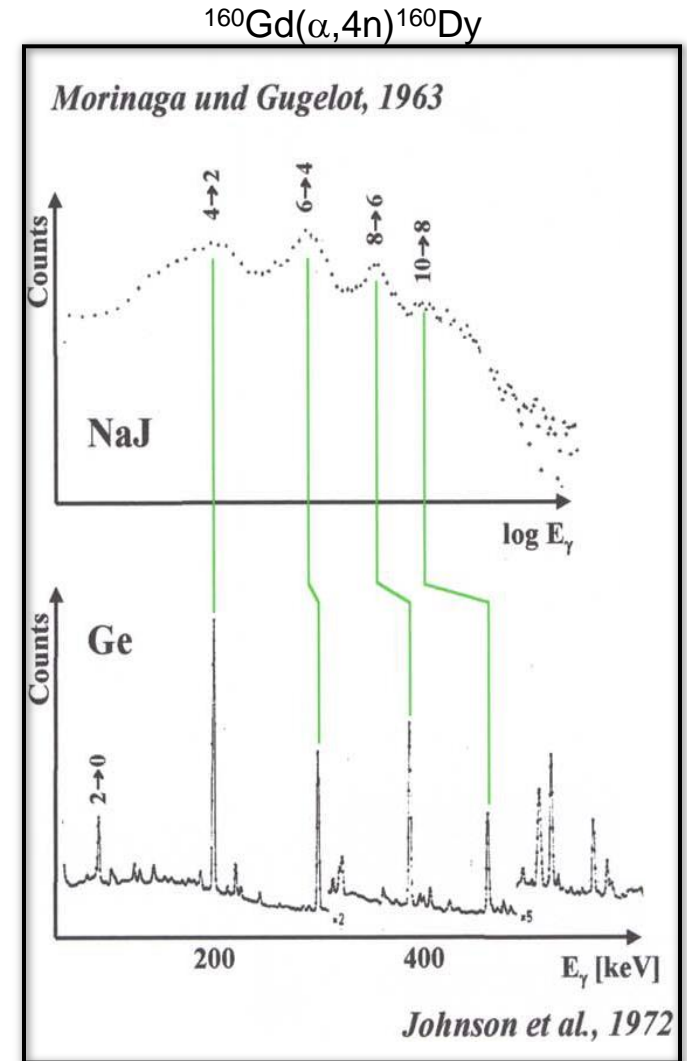
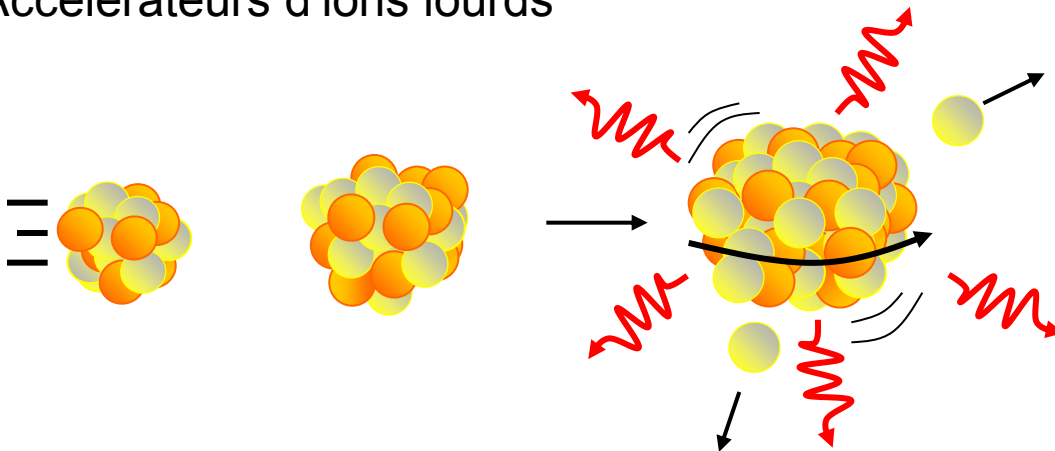

Des formes extrêmes

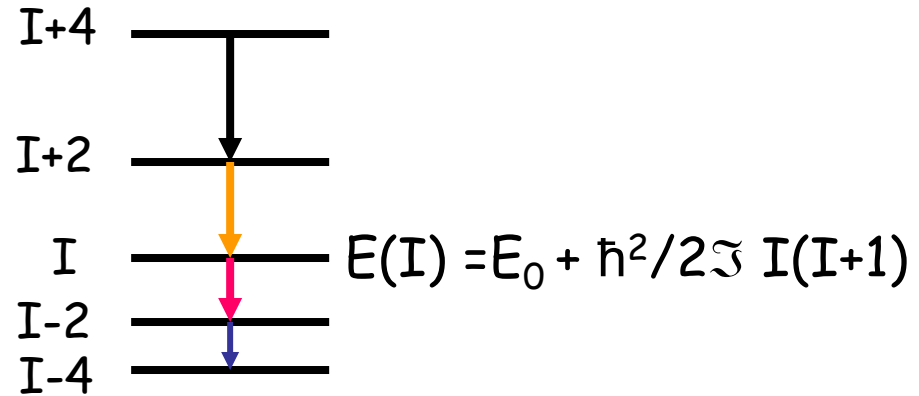

P.J. Twin et al., Phys. Rev. Lett. 57 (1986) 811
 T. Lauritsen et al., Phys. Rev. Lett. 88 (2002) 042501

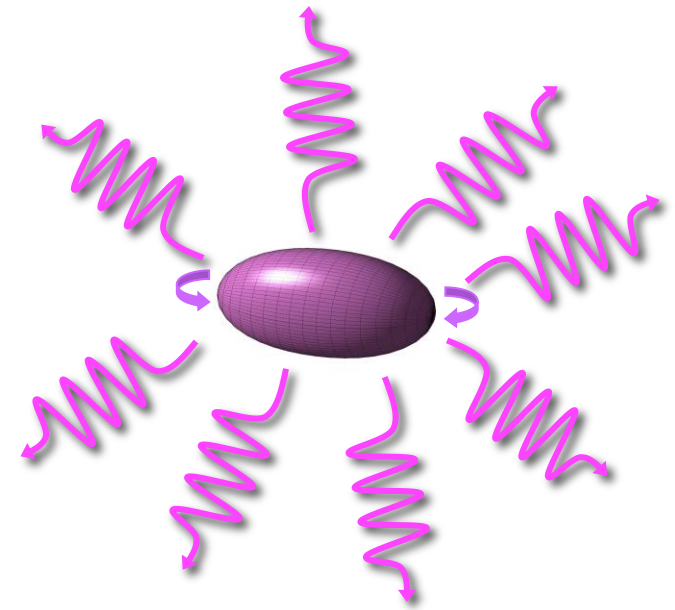
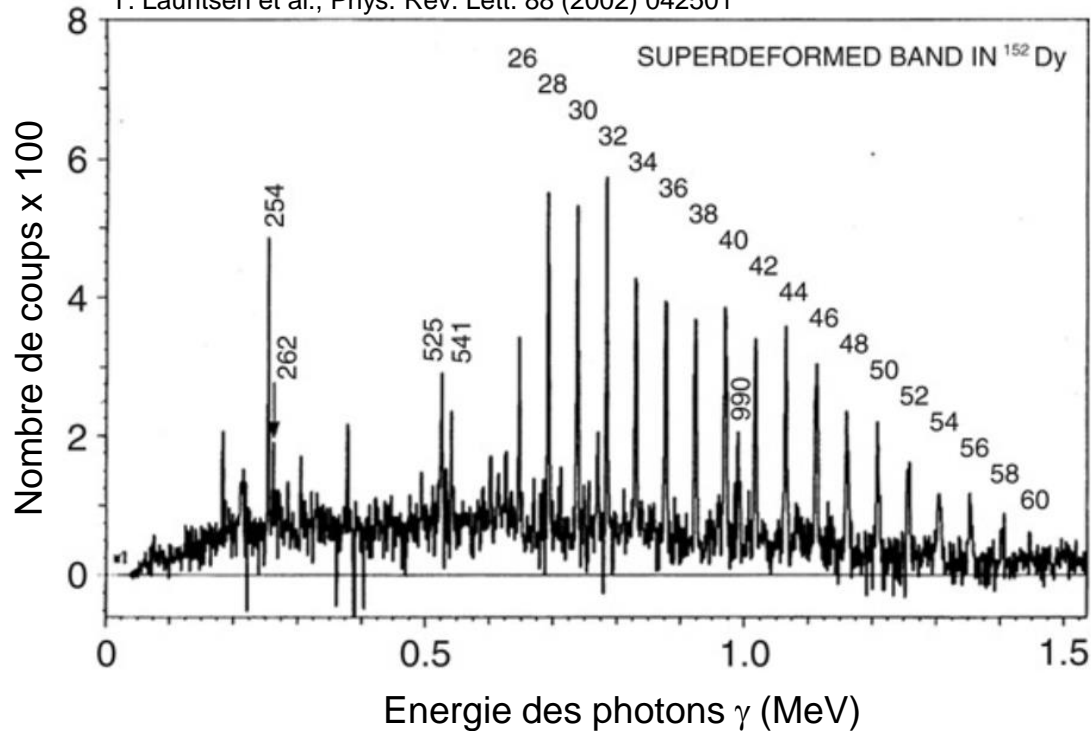

Détection γ de plus en plus performante

TESSA

ESS30

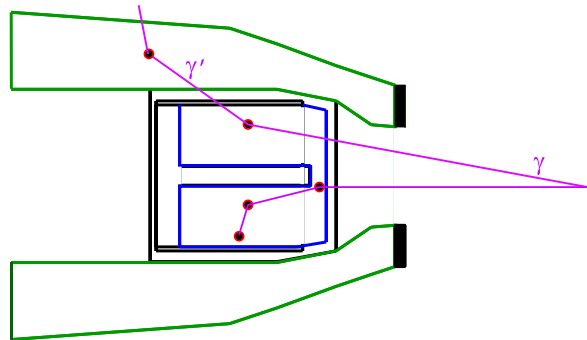
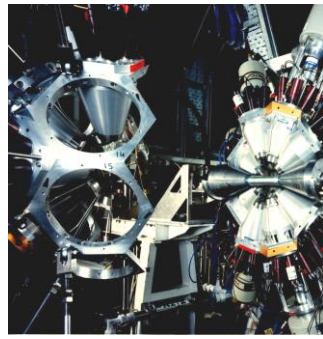

EUROGAM

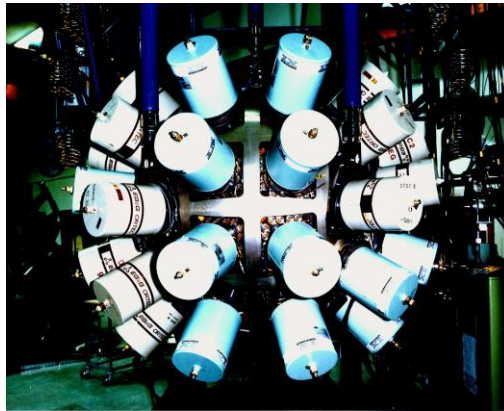

EUROBALL III

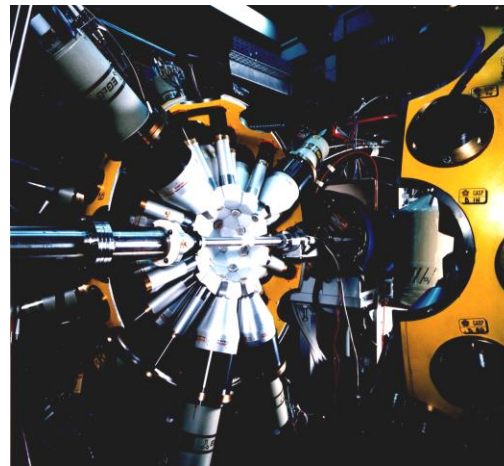

GASP

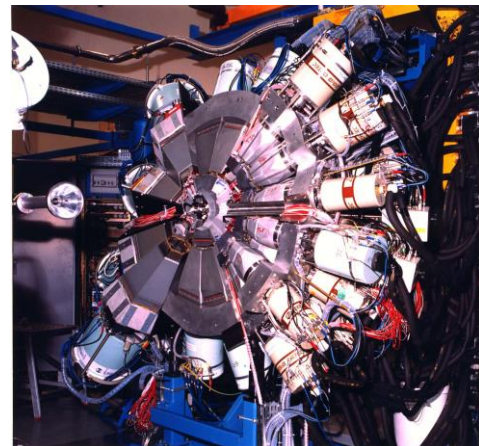

EUROBALL IV

1980

1986

1992

1996



Tracking γ

AGATA

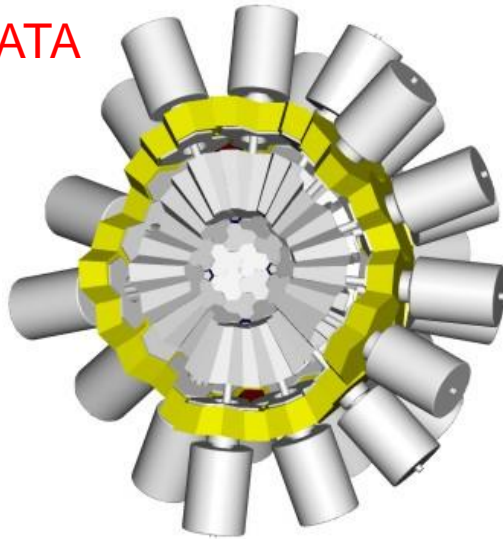

GRETA

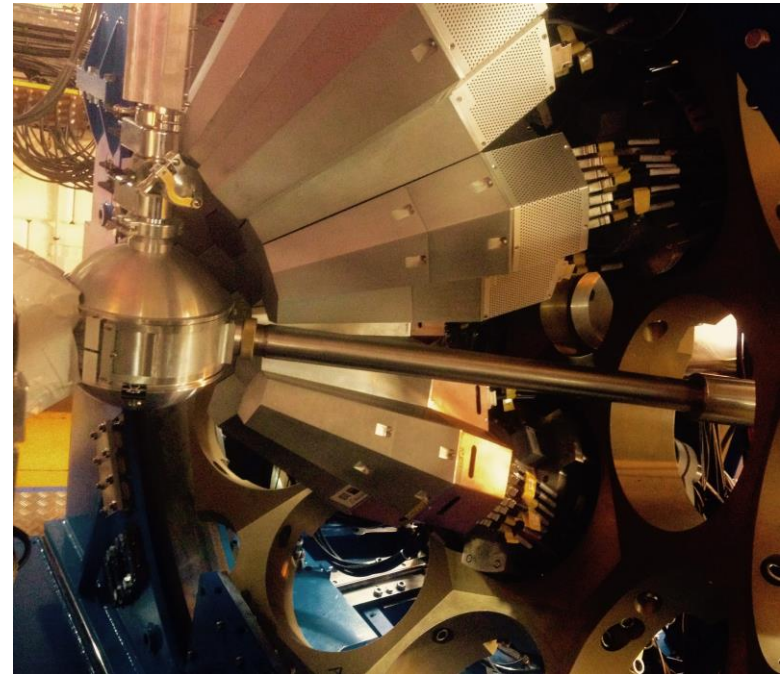
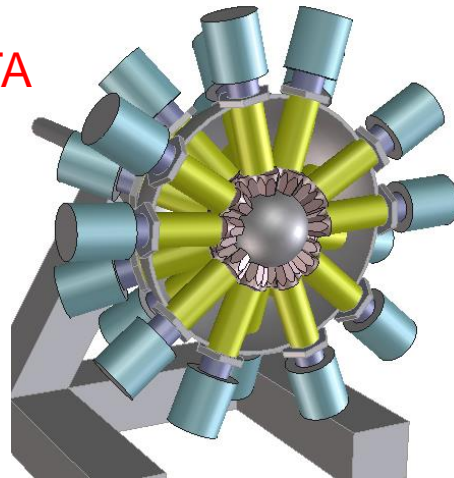

AGATA au GANIL (2014-)

1997 -

aujourd'hui

Des éléments extrêmes

J. Khuyagbaatar et al., Phys. Rev. Lett. 112 (2014) 172501

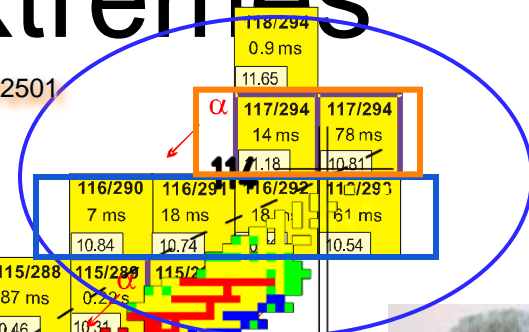

Yuri Oganessian

Y. Oganessian et al., Phys. Rev. Lett. 104, 142502 (2010)

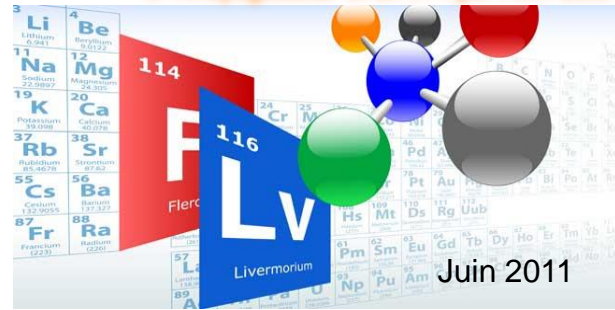

Jun 2011

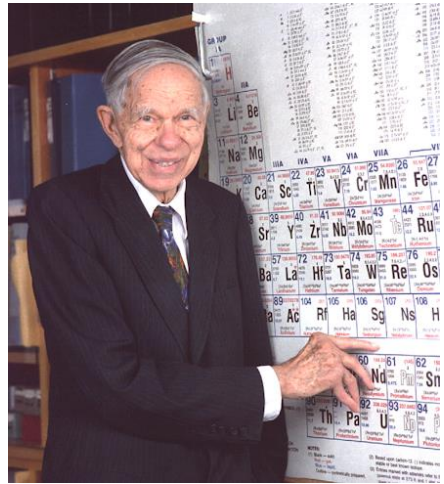

Glenn Seaborg

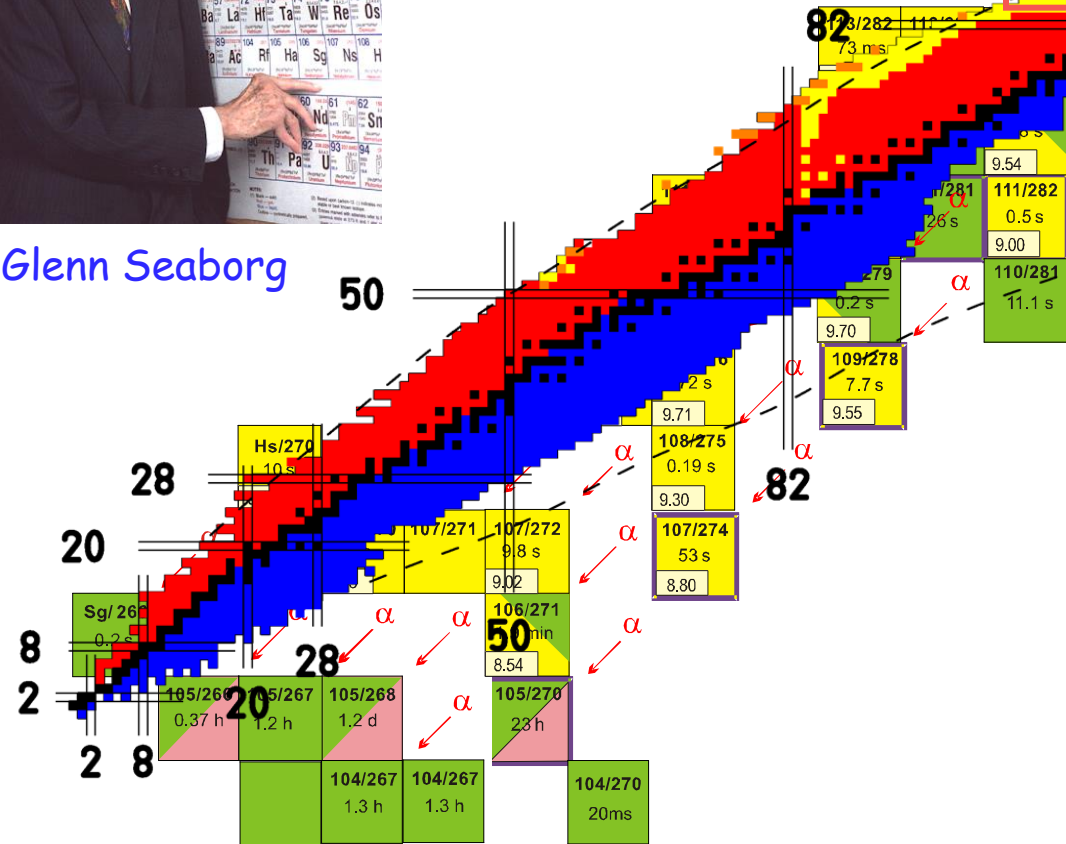

Juillet 2010

Sigurd Hofmann

L' aiguille dans la botte de foin

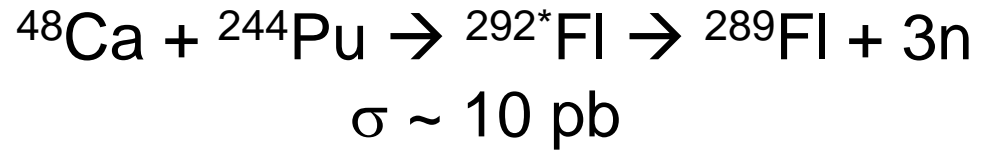
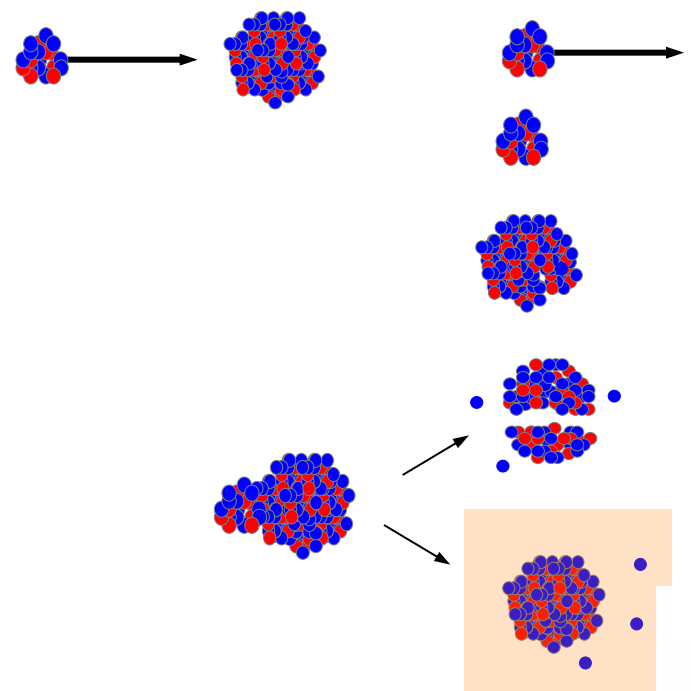

5 décroissances α du ${}^{289}\text{Fl}$ /semaine

$5 \cdot 10^{12} \text{ }^{48}\text{Ca/s}$

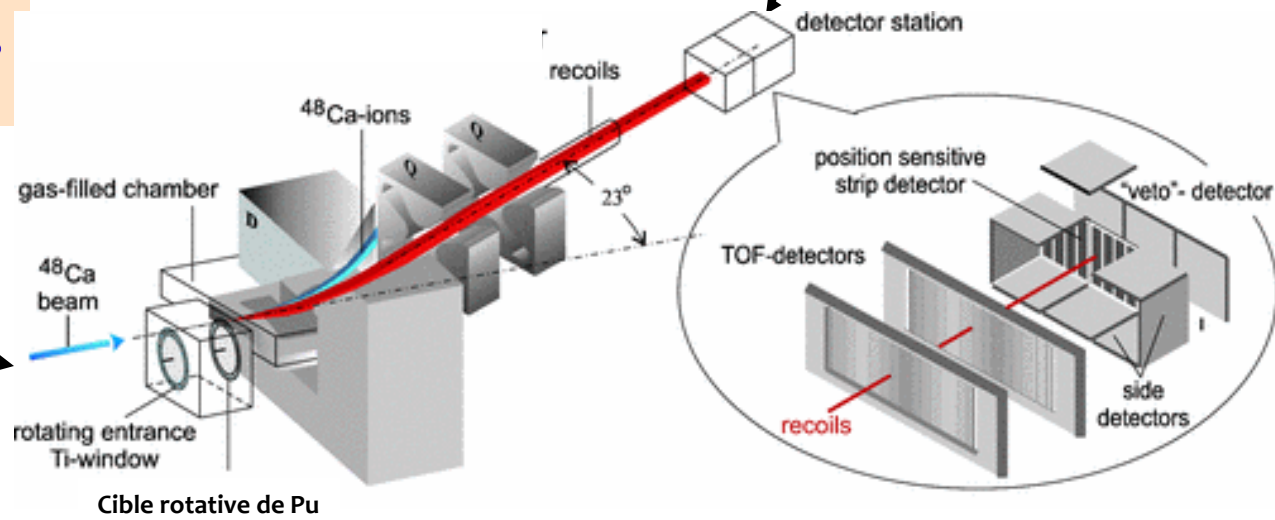

Les nombres magiques sont-ils universels ?

- Chaîne des Ni (Z=28): de A=48 (N=20) jusqu'à A=78 (N=50) ✓
- ^{28}O (Z=8, N=20): non lié ✗

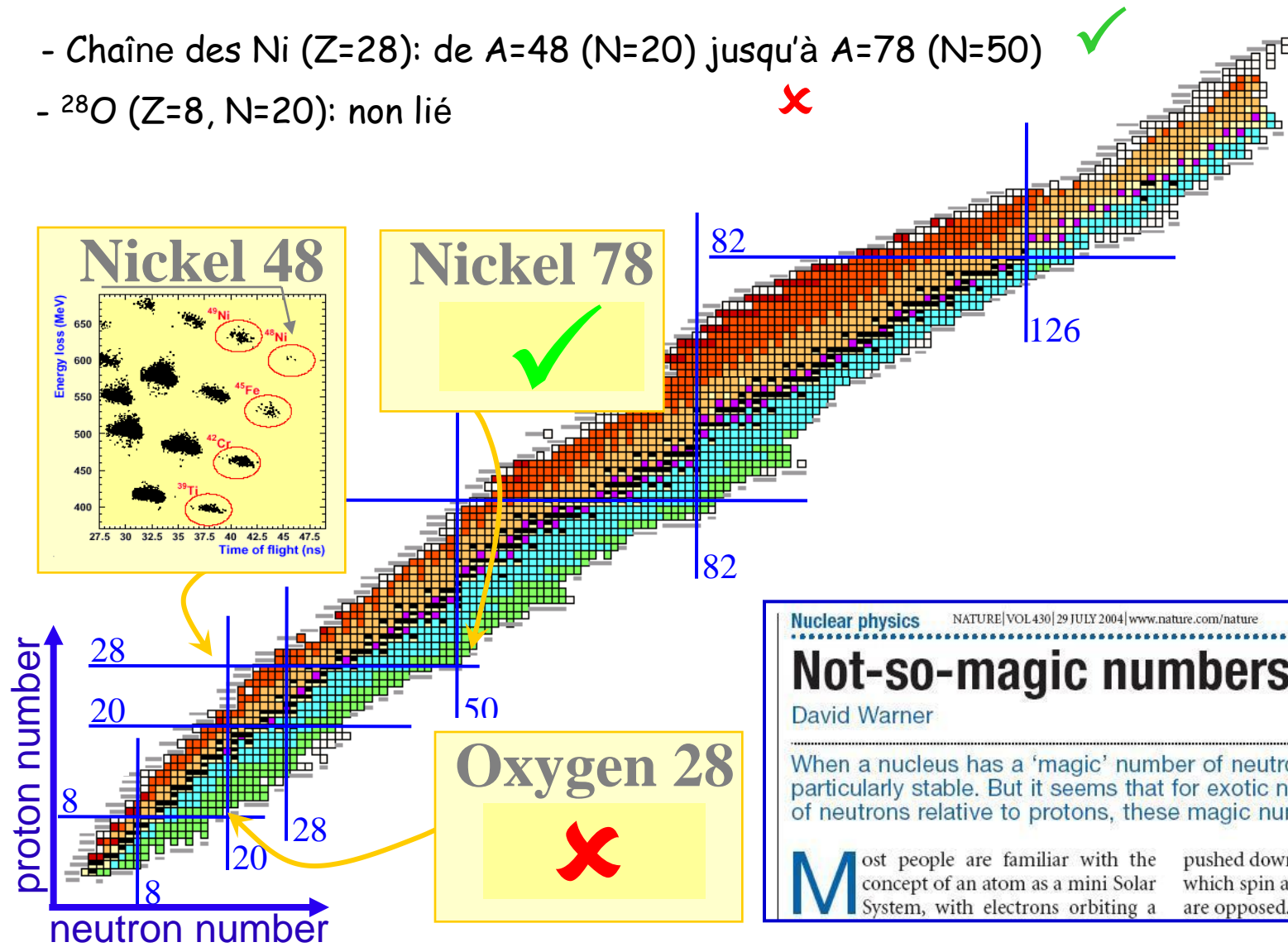

Nuclear physics NATURE | VOL 430 | 29 JULY 2004 | www.nature.com/nature news and views

Not-so-magic numbers

David Warner

When a nucleus has a 'magic' number of neutrons or protons, it is particularly stable. But it seems that for exotic nuclei, with large numbers of neutrons relative to protons, these magic numbers can change.

Most people are familiar with the concept of an atom as a mini Solar System, with electrons orbiting a nucleus. For stable nuclei, the magic numbers 2, 8, 20, 28, 50, 82, and 126 are pushed down in energy relative to orbits for which spin and orbital angular momentum are opposed. Theoretical studies^{4,5} attempt-

Disparition du gap à N=20

$^{40}\text{Ca} \rightarrow$ Doublement magique
 - énergie 2+ élevée
 - faible B(E2)
 \rightarrow sphérique



$^{36}\text{S} - ^{34}\text{Si} \rightarrow$ Simplement magique
 - énergie 2+ élevée
 - faible B(E2)
 \rightarrow sphérique



$^{32}\text{Mg} \rightarrow$ Simplement magique
 - faible énergie 2+
 - B(E2) élevé
 \rightarrow déformé

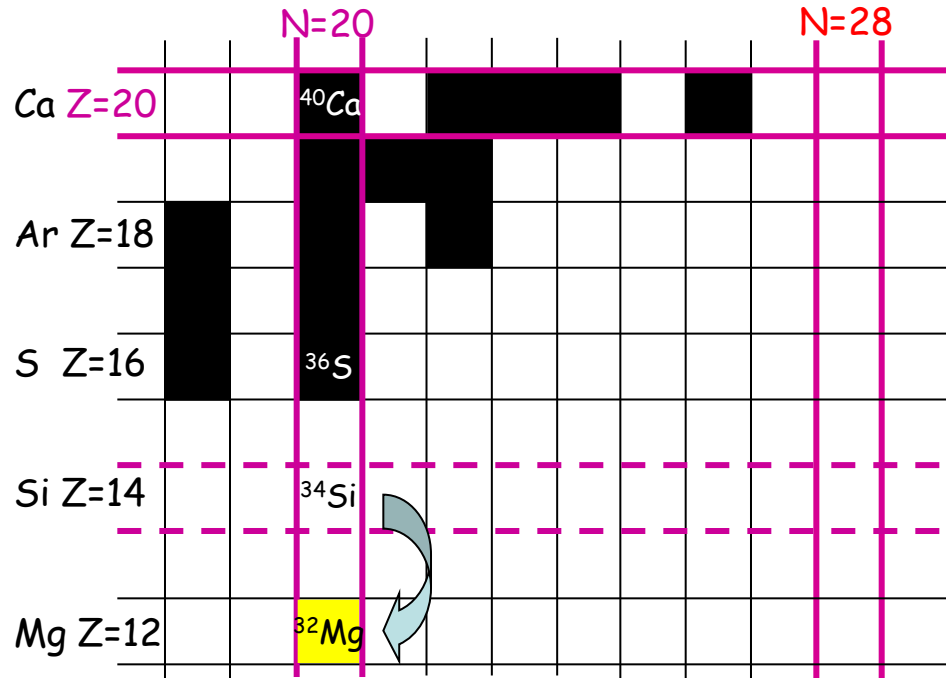
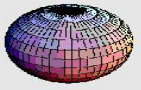

T. Otsuka et al., Phys. Rev. Lett. 95, 232502 (2005)

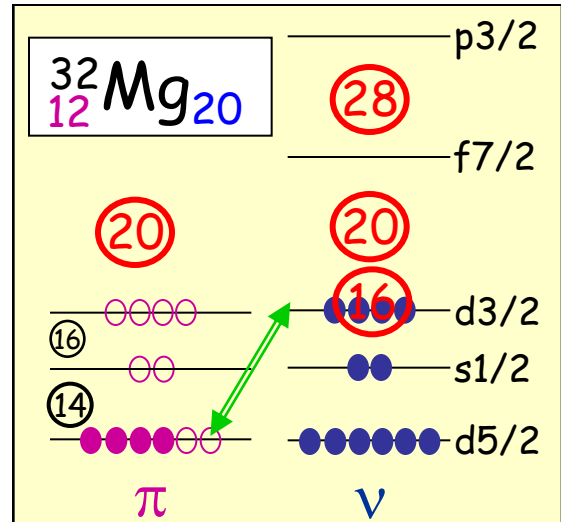
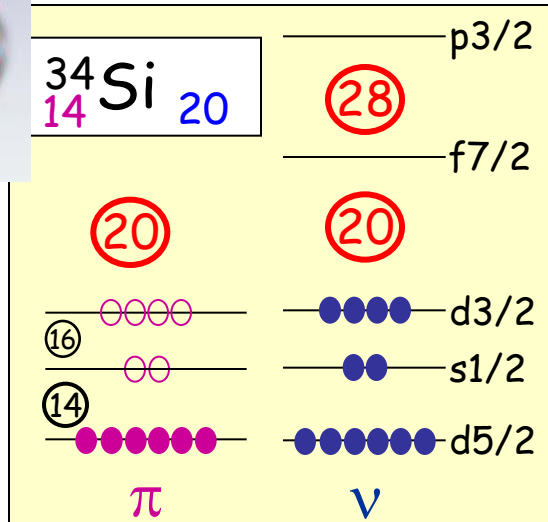
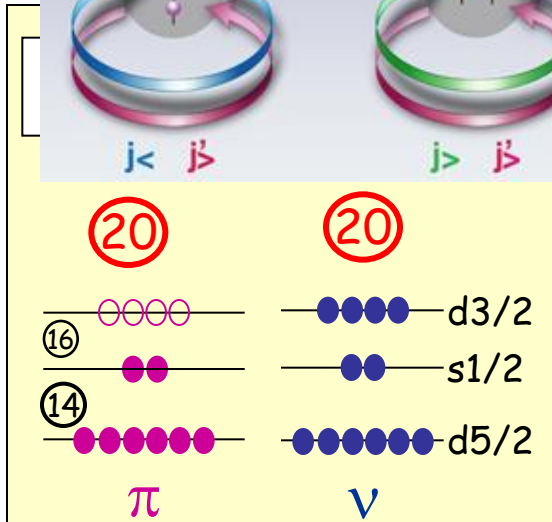
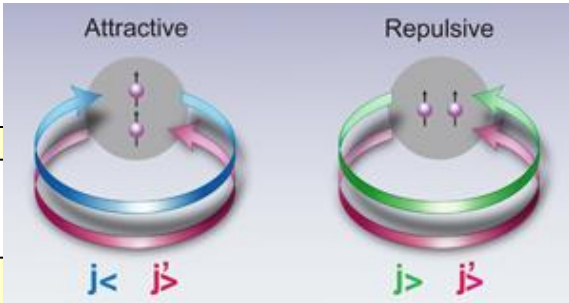

Nouveaux nombres magiques

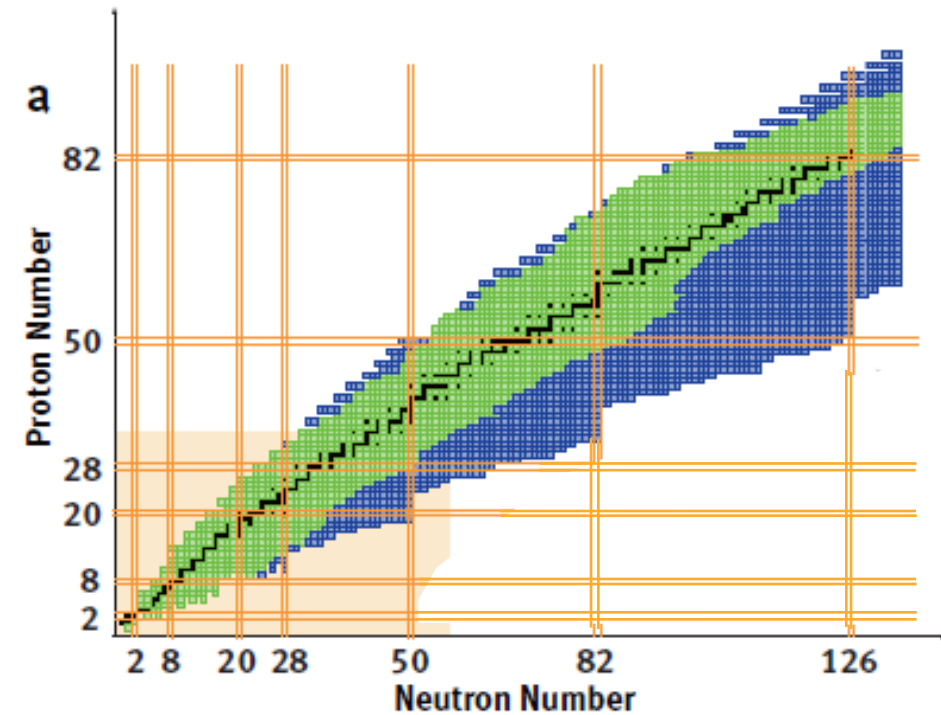

Le noyau dans tous ses états !

